

Safety Recall

N212345946 High Voltage Battery May Melt or Burn



Release Date: September 2024

Revision: 02

Revision Description: This bulletin is being revised to update the Parts Language. Please discard all previous copies of N212345946.

Attention: It is a violation of Federal law for a dealer to deliver a new motor vehicle or any new or used item of motor vehicle equipment (including a tire) covered by this notification under a sale or lease until the defect or noncompliance is remedied.

All involved vehicles that are in dealer inventory must be held and not delivered to customers, dealer traded, or used for demonstration purposes until the repair contained in this bulletin has been performed on the vehicle.

Danger: Carefully read this bulletin before beginning the remedy procedure. This bulletin contains important legal and safety requirements that must be followed in order to safely replace the vehicle's high voltage battery in compliance with applicable federal, state, provincial, and local laws. To avoid injury or death, use of a forklift is required to safely load and unload crated batteries into and out of delivery trucks. Failure to carefully follow the procedures in this bulletin may result in serious injury or death.

This is a phased launch.

For US Dealers: This recall must only be completed by Chevrolet EV certified dealers who have met all Bolt recall-specific training, tool and equipment requirements. Repairs must be performed by a technician who has successfully completed the required training.

For Canadian Dealers: Only Chevrolet Dealers who have signed the Chevrolet Electric Models Agreement and have met all the Chevrolet Bolt EV/EUV-specific training, tools, and equipment requirements are eligible to complete the repair. Any Dealer unsure of their eligibility status should immediately review with their District Service Manager.

| Make | Model | Model Year | | RPO | Description |
|-----------|----------|------------|------|-----|-------------|
| | | From | To | | |
| Chevrolet | Bolt EV | 2020 | 2022 | | |
| Chevrolet | Bolt EUV | 2022 | 2022 | | |

Involved vehicles are marked "Open" on the Investigate Vehicle History screen in GM Global Warranty Management system. This site should always be checked to confirm vehicle involvement prior to beginning any required inspections and/or repairs.

| | |
|-------------------|-----------------------------------------------------------------------------------------------------------------------------------------------------------------------------------------------------------------------------------------------------------------------------------------------------------------------|
| Condition | General Motors has decided that a defect which relates to motor vehicle safety exists in certain 2020-2022 model year Chevrolet Bolt EV, and 2022 model year Chevrolet Bolt EUV vehicles. The high voltage batteries in these vehicles may pose a risk of fire when charged to full, or very close to full, capacity. |
| Correction | Dealers will replace the high-voltage battery pack and install advanced diagnostic software that will monitor battery performance and identify defective battery modules that require replacement. |

Vehicle Preparation Before Entering the Repair Garage

The high voltage battery must be at a state of charge (SOC) less than 80%. (If the State of Charge is greater than 80%, follow the Adjusting (Reducing) the SOC procedure below.)

Record the final State Of Charge (SOC) on the repair order, prior to repair (Technician).

The Warranty Administrator will need to enter the State of Charge value in the "Reference Number" field of the warranty claim.

Once the vehicle is received for service it should not be plug-in charged until the replacement high voltage battery has been installed.

Safety Recall

N212345946 High Voltage Battery May Melt or Burn



Perform the following steps **BEFORE** the high voltage battery removal.

Adjusting (Reducing) the SOC



Important: Verify the vehicle SOC is less than 80%. This can be determined by looking at the bars on the power level indicator. If four or more empty bars (not showing green) are displayed, the SOC is at an acceptable level. If the power level indicator shows an SOC of greater than 80%, follow the bulleted procedure below until SOC is less than 80%.

Caution: During this procedure, a puddle of water may form around the vehicle from HVAC system drainage. Use care to prevent any slip/fall conditions.

Note: Each hour of operation will reduce SOC by about 10%. Left unattended, the vehicle will automatically turn OFF after 2 hours. This procedure must be performed in a secure location because the vehicle is in a drivable condition. Take proper steps to ensure no unauthorized drivers have access to the vehicle.

- Vehicle in PARK, Vehicle ON.
- Headlamps Low Beam: ON.
- Temp Control: Hi (Max Heat High) (note: windows should be down).
- Distribution: MAX Defrost (Engages AC Compressor).
- Fan Speed: High (8).
- Select: Fresh Air (Not recirc).
- Select: Heat & A/C.
- If equipped, turn heated seats to hi position.
- Verify SOC after 60 minutes. If the SOC is less than 80%, proceed with the steps below. If the SOC is above 80%, allow additional power burn off time.
- When the SOC adjustment is completed return the HVAC controls to 72 Deg. AUTO, Set the headlamp control to AUTO.

Safety Recall

N212345946 High Voltage Battery May Melt or Burn



Parts

| Quantity | Part Name | Part No. |
|----------|----------------------------|----------------------------|
| 1 | BATTERY ASM-HIGH VLTG | 24061836* |
| 1 | BATTERY ASM-HIGH VLTG | 24061757* |
| 2 | COOLANT ENGINE (50/50 Mix) | 12378390 US 10953456 CA |

* Either High Voltage Battery part number can be used to complete this recall. These parts are functionally the same. Please ONLY order one High Voltage Battery.

As a reminder high voltage battery assemblies are VIN specific.

WARNING: ONLY the VINs associated with this recall can use these specific high voltage battery assembly part numbers listed above. If VIN receives a part number other than those listed above it may result in future serviceability issues. The batteries listed in this recall are specific to the VINs in Open in IVH. Claims with incorrect part numbers may be debited.

Storage Guidelines for Containerized High Voltage Batteries

- Store the High Voltage Battery and shipping crate flat.
- Store the High Voltage Battery and shipping crate in an environmentally protected area (indoors).
- Protect the High Voltage Battery and shipping crate from exposure to liquids, including rain and snow.
- Protect the High Voltage Battery and shipping crate from physical damage.

Parts Ordering Information

For US Dealers:

In order to simplify the ordering process for high voltage batteries necessary to perform repairs under THIS RECALL, the high voltage battery ordering process requiring authorization from the Technical Assistance Center (TAC) is not required. Battery ordering will be completed using the "Bolt EV Battery Safety Recalls" app in GlobalConnect. The application can be located in either the "App Center" or "Parts Department" in GlobalConnect. All other high voltage battery orders NOT related to the recall must continue to be authorized through Technical Assistance. Once you locate and enter the app you will be connected directly to the Spiers New Technologies (SNT) ordering portal. At this point simply click the "Create New Recall Order" to begin the process to order part number 24061836 OR 24061757. Before visiting the SNT ordering portal, please have all required information available (shown below).

Note that in addition to order placement, this app is also used to arrange for the high voltage battery core return.



5903430

US dealers will get their replacement packaging materials through the SNT app in Global Connect (same app as they use to order and return the high voltage battery).

For Canadian Dealers:

High voltage batteries may be ordered from York Electronics by logging onto the York Electronics website (www.yorkelec.com) using the username and password created for your Dealership.

Canadian dealer online order process:

- Log in to the website.
- Click on the Bolt EV/EUV Battery Recall icon.
- Complete all required fields and submit the order.
- A copy of the order will be emailed to the email address used to log into the online order system.

Safety Recall

N212345946 High Voltage Battery May Melt or Burn



- Once the order is processed by the York Electronics order desk, a confirmation email from York will be sent indicating the order was successfully received.

Note: For concerns with the online ordering process, please contact YORK ELECTRONICS OSHAWA at 1-888-650-9675 ext. 307.

Required Information for U.S. and Canada

Dealer Name: _____

Dealer Code: _____

Shipping Address: _____

Contact At Dealership (include phone number and email address): _____

Dealerships Preferred Dealer Delivery Time/Date for Dealer Forklift Operator (Must be within 24 hours of the order time): _____

Hours of operation: _____

VIN # _____

Model Year: _____

Parts Retention and Return

Parts Retention and Returns (United States Service Agents ONLY)

All high voltage Li-Ion batteries are GM assets and are required to be returned. Dealers are to return the high voltage battery as soon as possible after completion of the repair. If the batteries are not **returned within 30 days**, the dealer will be charged back a core charge.

Important: Shipment of these high voltage Li-Ion batteries is regulated by dangerous goods transportation laws. GM Dealer Parts and Accessories Policies and Procedures requires that dealers comply with all applicable dangerous goods transportation laws, including but not limited to having at least one employee be certified in the transportation of dangerous goods as required by law. Additional resources for dangerous goods transportation can be found as part of appendix G in the latest version of Service Bulletin #99-00-89-019. All dangerous goods must be shipped in accordance with all applicable federal, state, provincial, and local laws.

Drive Motor Battery Core Return Process (United States Service Agents ONLY)

Important: Dealers must submit a core return request through the “Bolt EV Battery Safety Recalls” app in Global Connect. The app is available in the Global Connect App Center. It is the same app used to order batteries for the recall. **DO NOT CALL CCA Logistics or XPO directly.**

Important: For shipping preparation instructions, refer to “Final Shipping Preparation” information following the Service Procedure at the end of this bulletin.

DO NOT wait for the warranty claim to be processed before returning the removed high voltage battery. This part is GM’s material and is not claimed under the warranty labor operation. Place a copy of the repair order with the high voltage battery to be returned. Failure to return a copy of the repair order with the shipment may result in a debit. Attach the completed return shipping tag to the shipping crate. DO NOT return the high voltage battery in any crate other than the crate that the service high voltage battery was delivered in. The removed unit must be returned complete in the original shipping crate.

For questions about your order status, how to return exchanged material, or to verify battery receipt contact:

1-833-33 GM BSC (1-833-334-6272)

Drive Motor Battery Core Return Process (Canadian Service Agents ONLY)

Important: For shipping preparation instructions, refer to “Final Shipping Preparation” information following the Service Procedure at the end of this bulletin.

Email to arrange LTL pickup for the high voltage battery:

Send an email to: GMBatteryReturns@rxo.com.

You will be required to provide size (l x w x h) and weight. This information is available on the GM0003 tag. If your facility does not have a loading dock, please ensure RXO understands that this shipment will be loaded at ground level. (LTL carrier will need to bring required equipment).

Safety Recall

N212345946 High Voltage Battery May Melt or Burn



Specify Return address:

Vancouver Serviced Dealers: TST Overland Express Burnaby
7867 Express Street 111
Burnaby, BC

Edmonton Serviced Dealers: Day & Ross Edmonton X-Dock
11727 – 178th Street
Edmonton, Alberta

Woodstock Serviced Dealers: Day & Ross Woodstock X-Dock
520 Beards Lane, Unit B
Woodstock, Ontario

Montreal Serviced Dealers: Day & Ross Montreal X-Dock
5000 Trans Canada Hwy
Pointe Claire, PQ

For individual batteries over 500 kg. (1102 lbs.) – included with your new battery will be four (4) Class 9 TDG placards. Please provide these to the driver and **ensure** placards are affixed to the vehicle before departing.

Refer to GM GlobalConnect for the latest GM Canada Parts Bulletin (GMP2021-213) relating to procedures for return of EV Batteries or Sections. This can be found under Parts Bulletins & Resources located in the application section of the Parts Department page.

Canadian Dealers DO NOT return batteries to the ESC or to the WPC.

Note: If the removed high voltage battery is not returned within 30 days of receipt of the exchange component, the entire transaction will be debited, and the dealer will also be charged the value of a service high voltage battery.

Important: The high voltage battery may also be referred to drive motor battery throughout this service procedure.

Warranty Information

| Labor Operation | Description | Labor Time | Trans. Type | Net Item |
|-----------------|---------------------------------------------------------------------------------------------------------------------------------------------------------------------------------------------------------------------------------------------------------------------------------------------------|-------------------|-------------|----------|
| 9107358* | Drive Motor Battery Replacement and Shipping Preparation (Includes Hybrid Powertrain Control Module 2, Battery Energy Control Module, and Body Control Module reprogramming, Capacity Learn, EV Range Reset) (Using Forklift) (2020-2021) ADD: Using Engine Hoist ADD: SOC Depletion to 80% | 5.0 0.5 0.3 | ZFAT | ** |
| 9107366* | Drive Motor Battery Replacement and Shipping Preparation (Includes Hybrid Powertrain Control Module 2, Battery Energy Control Module reprogramming, Capacity Learn, EV Range Reset) (Using Forklift) (2022MY) ADD: Using Engine Hoist ADD: SOC Depletion to 80% | 4.5 0.5 0.3 | ZFAT | ** |

Important: * To avoid warranty transaction rejections, carefully read and follow the instructions below:

Labour Time [\[Top\]](#)

Labour Operation Code:

Additional labour op code information:

SPS Warranty Claim Code:

6125814

Safety Recall

N212345946 High Voltage Battery May Melt or Burn



- The Warranty Claim Code from the programming event must be accurately entered in the “Warranty Claim Code” field of the transaction.
- When more than one Warranty Claim Code is generated for a programming event, it is required to document all Warranty Claim Codes in the “Correction” field on the job card. Dealers must also enter one of the codes in the “Warranty Claim Code” field of the transaction, otherwise the transaction will reject. It is best practice to enter the FINAL code provided by SPS2.

Warranty Claim Code Information Retrieval

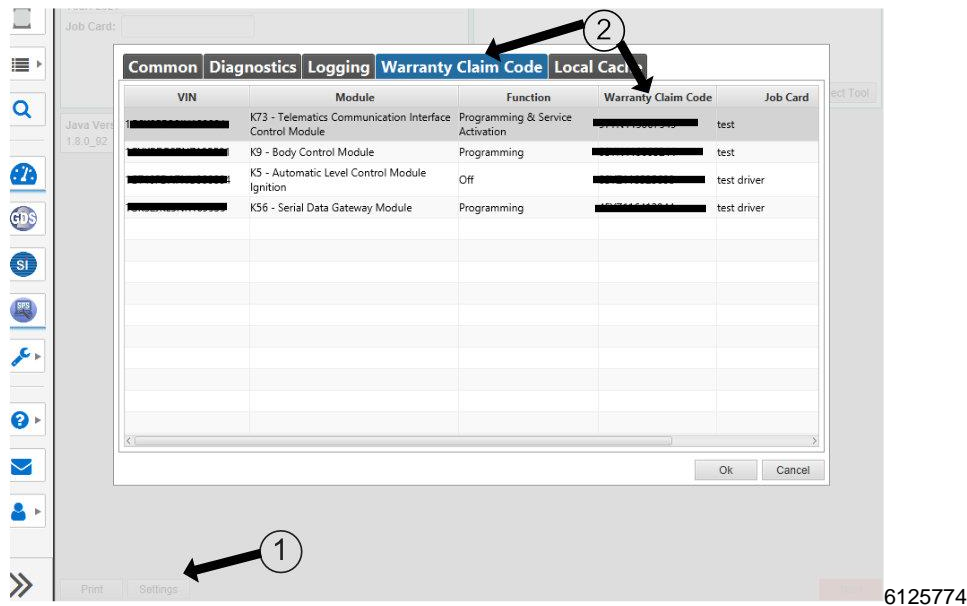

If the Warranty Claim Code was not recorded on the Job Card, the code can be retrieved in the SPS2 system as follows:

1. Open TLC on the computer used to program the vehicle.
2. Select and start SPS2.
3. Select Settings (1).
4. Select the Warranty Claim Code tab (2).

The VIN, Warranty Claim Code and Date/Time will be listed on a roster of recent programming events. If the code is retrievable, dealers should resubmit the transaction making sure to include the code in the SPS Warranty Claim Code field

** Submit a \$520.00 USD (\$624.00 CAN) administrative part allowance. Add this amount in the Administrative Allowance Net Item field when submitting the repair transaction.

** Submit a \$600.00 USD (\$720.00 CAN) administrative allowance for recall specific impacts to technician and service department throughput, Business Development Centers, high voltage battery handling and storage, tools and equipment, including forklifts, and miscellaneous shop supplies.

** Submit a \$20.00 (\$25.00 CAN) administrative allowance for return of the used high voltage battery assembly (document preparation and packaging). Add this amount in the Administrative Allowance Net Item field when submitting the repair transaction.

For Export Only – Submit an administrative allowance for return of the used high voltage battery assembly (document preparation and packaging). Add 0.2 in the labor time field when submitting the repair transaction.

Identification Number Recording for All High Voltage Battery Replacements:

Safety Recall

N212345946 High Voltage Battery May Melt or Burn



Authorization/Comments Section [\[Top\]](#)

General Comments

Comments

5911790

Important: (TECHNICIAN and WARRANTY ADMINISTRATOR) REQUIREMENT FOR THE SERVICE HIGH VOLTAGE BATTERY. The replacement battery identification number must be captured by the technician and recorded on the job card. The Warranty Administrator MUST enter the service high voltage battery identification number in GWM (Global Warranty Management) or in DMS (Dealer Management System). Enter the identification number of the service high voltage battery in the 'Comments' field per the screen above. Failure to enter this identification number will cause the claim to reject.

Tool Specifications:

Necessary tools for loading and unloading:

Forklifts are a requirement to load and unload crates from the transportation trailer.

- 3,000 lbs. (1370 kg). capacity or larger.
- 60 inch (152 cm) forks 48 inch (122 cm) are acceptable for already existing forklifts.
- Stand-up, sit-down or walkie forklifts are acceptable.

Pallet Jacks are acceptable to move crates on flat surfaces including the interior of a trailer.

- 3,000 lbs. (1370 kg) capacity or larger.
- 48-60 inch (122-152 cm) forks.
- Recommended fork separation: 20 inch (51 cm).

Loading/Unloading Docks.

- Docks are preferred if available.
- Pallet Jacks are an acceptable option to load and unload in docks.
- Dock wells with grades exceeding 10% require a forklift, no pallet jacks allowed.

Necessary tools for moving crate within dealership and loading/unloading high voltage batteries in/out of crate.

Forklift (recommended).

- 3,000 lbs. (1370 kg) capacity; chain or lifting attachment; 48 inch (122cm) forks.

Engine Hoist (if Forklift not available).

- ½ ton capacity (454 kg); front leg width 36 inch (91 cm) max; lift 87 inch (221 cm) min.
- Process below defined for 8 inch (20 cm) top of legs.

Pallet Jack.

- 3,000 lbs. (1370 kg) capacity; 7 inch (18 cm) lift minimum; 48 inch (122 cm) forks.

Cribbing for REMOVED high voltage battery when using Forklift (when removing from Lift Table and placing on ground).

- Two (2) 4x4s length 60 inch (152 cm) (minimum).

Cribbing for REMOVED high voltage battery when using Engine Hoist (when removing from Lift Table and placing on ground).

- Four (4) Jack Stands –w/stable base (square) and capable of holding 1,000 lbs. (454kg).
- Two (2) 4x4s length 60 inch (152 cm) (minimum).

Cribbing for crate when using Engine Hoist.

- Two (2) 4x4s length 48 inches (122 cm) (minimum).
- Two (2) 4x4s length 60 inches (152 cm) (minimum).
- Two (2) 2x4s length 60 inches (152 cm) (minimum).

Safety Recall

N212345946 High Voltage Battery May Melt or Burn



Warning: Do not use a vehicle lift to retrieve a battery from the crate or place a battery in the crate to avoid serious injury.

Personal Protective Equipment:

Loading and Unloading:

- Safety glasses.
- General use gloves (Hy-flex, Mechanix).
- Substantial footwear.

Crating and Retrieving:

- Safety glasses.
- General use gloves (Hy-flex, Mechanix).
- Substantial footwear.

High Voltage Battery installation/removal:

- Safety glasses.
- Class 0 Electrical gloves with leather protectors during harness connections/disconnections.
- General use gloves (Hy-flex, Mechanix) for mechanical tasks.
- Substantial footwear.
- Bump caps for work underneath lifted vehicle.

High Voltage Battery Replacement Service Procedure

Danger: Carefully read this bulletin before removing the vehicle's battery and unpackaging/installing the new high voltage battery into a vehicle. This bulletin contains important legal and safety requirements that must be followed in order to safely replace the vehicle's high voltage battery in compliance with applicable federal, state, provincial, and local laws. Failure to carefully follow these procedures may result in serious injury or death.

- *Printed instructions are also provided in the high voltage battery crate.*
- *Do not discard or destroy the crate containing the new high voltage battery. The crate is required to return the used high voltage battery.*
- *Read and follow the crate unloading, loading, storage, and packaging instructions in this bulletin. When shipped, the high voltage battery is regulated as dangerous goods and all service agents must follow all applicable International, Federal, State, Provincial, and/or Local laws when preparing dangerous goods shipments including but not limited to classification, packaging, marking, labeling, and shipping dangerous goods.*



5903431

When lifting and moving the crate with the high voltage battery inside, be aware of the Center of Gravity (CG) as noted on the long sides of the crate. Fork mast should be centered with this mark and forks should be widened out to their maximum width and equally spaced on either side of the CG mark.

Warning: The use of a forklift is required when loading and unloading high voltage batteries into and out of delivery trucks. Other methods of loading and unloading have been deemed unsafe. Use a forklift to avoid serious injury.

Caution: Be sure to set up a temporary location for the removed battery until final shipping preparation. Do not expose the crate to rain, snow or any other environment that will cause moisture related damage.

Special Tools

Safety Recall

N212345946 High Voltage Battery May Melt or Burn



- EL-48900 HEV Safety Kit.
- EL-51102 High Voltage Battery Lift Bar Tilter.
- EL-51102-10 Lift Lateral Bar and Shackle Set.
- EL-51102-20 High Voltage Battery Lift Bar Tilter Eye-Nut Kit.
- EL-51102-40 Battery Lifting Strap (QTY 2).
- EL-51102-50 Battery Lifting Strap (QTY 4).
- EL-52016-1A Coolant Passage Test Adapter Kit (Included in 52016-A Kit)
- EL-52016-2A Coolant Pressure Tester Adapter Plug (Included in 52016-A Kit)
- GE-52200-A Lifting Table.

For equivalent regional tools, refer to Special Tools in SI.

Danger: Always perform the High Voltage Disabling procedure prior to servicing any High Voltage component or connection. Personal Protection Equipment (PPE) and proper procedures must be followed.

The High Voltage Disabling procedure includes the following steps:

- Identify how to disable high voltage.
- Identify how to test for the presence of high voltage.
- Identify condition under which high voltage is always present and Personal Protection Equipment (PPE) and proper procedures must be followed.
- Before working on any high voltage system, be sure to wear the following Personal Protection Equipment:
 - Safety glasses with appropriate side shields when within 15 meters (50 feet) of the vehicle, either indoors or outdoors.
 - Certified and up-to-date Class "0" Insulation gloves rated at 1000V with leather protectors.
- Visually and functionally inspect the gloves before use.
- Wear the Insulation gloves with leather protectors at all times when working with the high voltage battery assembly, whether the system is energized or not.

Failure to follow the procedures may result in serious injury or death.

Service Procedure

Safety Recall

N212345946 High Voltage Battery May Melt or Burn



5905973

Important: Verify the vehicle SOC is less than 80%. This can be determined by looking at the bars on the power level indicator. If four or more empty bars (not showing green) are displayed, the SOC is at an acceptable level. If the power level indicator shows an SOC of greater than 80%, refer to the *Vehicle Preparation Before Entering the Repair Garage* section at the beginning of this document.

Remove the Drive Motor (High Voltage) Battery

1. Disable the high voltage system. Refer to *High Voltage Disabling* in SI.
2. Remove the front compartment air deflector. Refer to *Front Compartment Air Deflector Replacement* in SI.
3. Drain the drive motor battery cooling system. **The high voltage battery must be drained completely using the Vac-N-Fill Procedure before removal from the vehicle, static draining is not sufficient. The Vac-N-Fill Procedure must also be used when refilling the drive motor battery cooling system. If the Vac-N-Fill Procedure is not used, the customer will return to the dealership with a low coolant condition.** Refer to *Drive Motor Battery Cooling System Draining and Filling* in SI.

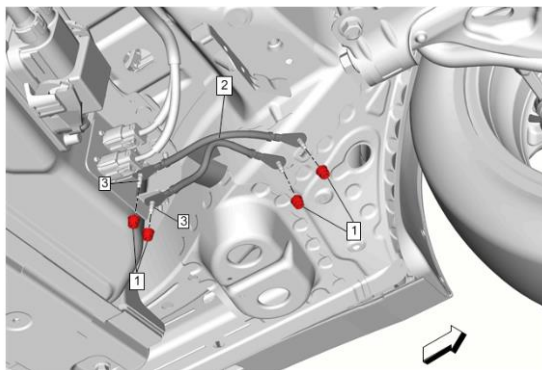

4505400

4. Remove the high voltage battery negative cable (2) from the high voltage battery and body structure. Refer to *Battery Negative Cable Replacement* in SI.

Safety Recall

N212345946 High Voltage Battery May Melt or Burn

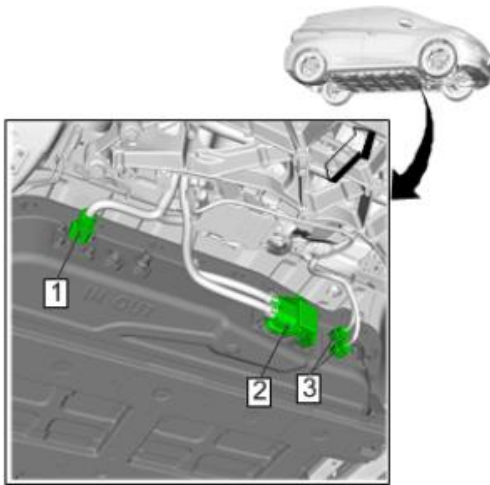

4834281

5. Disconnect the X4 high voltage battery connector (1) from the drive motor (high voltage) battery.
6. Disconnect the X3 high voltage battery connector (2) from the drive motor (high voltage) battery by rotating the connector handle until 90 degrees.
7. Disconnect the body wiring harness connectors (3) from the drive motor (high voltage) battery.

Danger: To avoid any vehicle damage, serious personal injury, or death:

- When major components are removed from the vehicle and the vehicle is supported by a hoist, support the vehicle with jack stands at the opposite end from which the components are being removed and strap the vehicle to the hoist.
- When performing work in the engine compartment or under the vehicle, ensure that the hood is fully open, or opened to its secondary latch. When the hood is opened to the secondary latch, the vehicle will disable the remote start features from the key fob and OnStar mobile app. Failure to open the hood or open the hood to the secondary latch while doing a repair in the engine compartment or under the vehicle can result in inadvertent vehicle starting which could result in personal injury, death, or damage to a vehicle.

Caution: Perform the following steps before beginning any vehicle lifting or jacking procedure:

- Remove or secure all of the vehicle contents in order to avoid any shifting or any movement that may occur during the vehicle lifting or jacking procedure.
- The lifting equipment or the jacking equipment weight rating must meet or exceed the weight of the vehicle and any vehicle contents.
- The lifting equipment or the jacking equipment must meet the operational standards of the lifting equipment or jacking equipment manufacturer.
- Perform the vehicle lifting or jacking procedure on a clean, hard, dry, level surface.
- Perform the vehicle lifting or jacking procedure only at the identified lift points. DO NOT allow the lifting equipment or jacking equipment to contact any other vehicle components.

Failure to perform the previous steps could result in damage to the lifting equipment or the jacking equipment, the vehicle, and/or the vehicle contents.

8. During drive motor battery removal, vehicle weight will be redistributed and may cause the vehicle to become unstable on the hoist. To avoid the vehicle potentially falling off, secure the vehicle to lift/hoist arms with straps.

Safety Recall

N212345946 High Voltage Battery May Melt or Burn

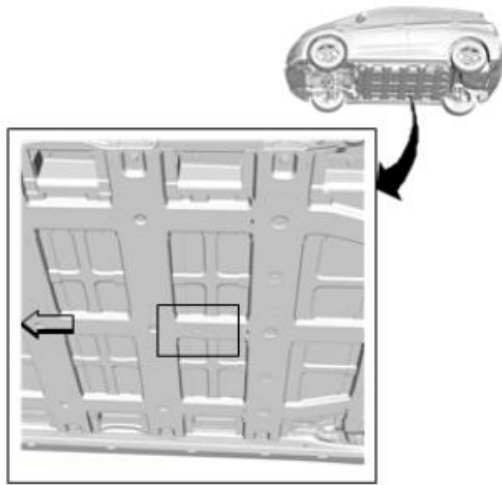

4507200

Warning: The GE-52200-50 lift table limiting chain is for use with GE-52200 lifting tables not equipped with a mechanical stop. Refer to the operating instructions provided with the limiting chain. Failure to limit uncontrolled descent of the lifting table may result in vehicle or high voltage battery damage and/or serious injury.

Note: There is a CG (Center of Gravity) mark on the drive motor battery tray to position your lift table.

Note: The high voltage battery mass is approximately 1000 lbs. (450 kg).

9. Position a GE-52200 Lifting Table and raise the lifting table into position.

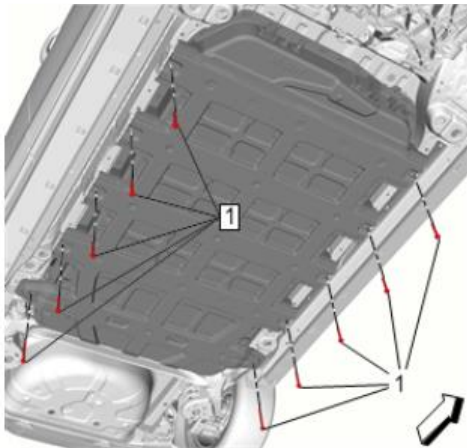

4834282

Note: Verify ALL connectors are removed from the drive motor battery.

Note: Confirm the locking MSD cap/cover required in some regions will pass through the vehicle floor panel. If not, the MSD cap/cover should be removed during high voltage battery lowering from vehicle then reinstalled once the battery is out.

Note: Ensure all fasteners are removed before lowering the support table fixture with the drive motor battery.

10. Remove the drive motor battery mounting fasteners (1).

Safety Recall

N212345946 High Voltage Battery May Melt or Burn



4587655

Danger: When removing the high voltage battery, only use the recommended lift table with straps capable of holding 2205 lbs. (1000kg). Failure to use the appropriate lift table and straps could cause the battery to fall and may result in serious injury or death.

11. Slowly lower the lifting table (1) with the drive motor battery (2).
12. Secure the high voltage battery to the lifting table with straps.

Removed Battery Cribbing Setup with Forklift

1. Set-up two (2) 4x4s 27 inches apart (69 cm) (inside measurement) to allow battery frame to sit on 4x4s.

Caution: DO NOT place battery directly on ground or directly on jack stands (without 4x4s).

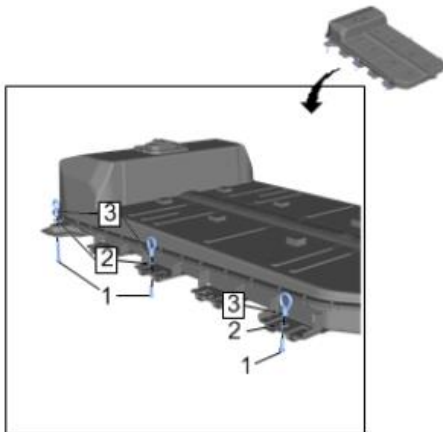

4587656

2. Using the EL-51102-20 High Voltage Battery Lift Bar Tilter Eye-Nut Kit install the 3 eye-nut (3), washers (2) and bolts (1). The longer bolts should be used on the “heavy” side of the battery.

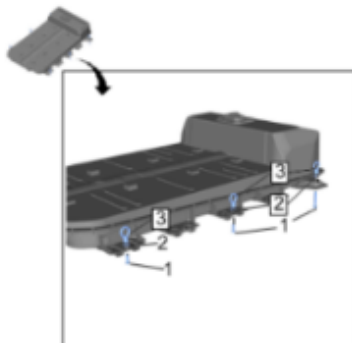

4587657

3. Using the EL-51102-20 High Voltage Battery Lift Bar Tilter Eye-Nut Kit install the 3 eye-nut (3), washers (2) and bolts (1). The longer bolts should be used on the “heavy” side of the battery.

Safety Recall

N212345946 High Voltage Battery May Melt or Burn

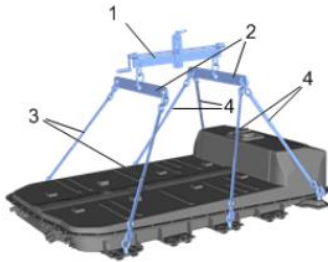

4587658

Assemble Lifting Kit

- EL-51102 High Voltage Battery Lift Bar Tilter (1).
 - EL-51102–10 Hanging Bars and Shackles (2).
 - EL-51102–40/50 Battery Lifting Strap (3) and (4).
4. Attach Lifting Kit to forklift (with appropriate chain/attachment).
 5. Position the EL-51102 High Voltage Battery Lift Bar Tilter and EL-51102–10 Hanging Bars and Shackles (2) over the high voltage battery.
 6. Attach lift kit straps to eyebolts on REMOVED high voltage battery on Lift Table.
 - Ensure Lifting Straps (4) attach the heavy end of the high voltage battery.
 - Adjust Tilter to bias the vertical bar about 8 inches from end with the handle.
- Note:** Make sure the drive motor battery is balanced when hung from the lifting straps before moving with a forklift (with appropriate chain/attachment) to the Lifting Table.
- Note:** As part of the battery removal process, all coolant should be drained from the high voltage battery. The high voltage battery must be drained completely using the Vac-N-Fill Procedure before removal from the vehicle. Static draining is not sufficient. The Vac-N-Fill Procedure must also be used when refilling the drive motor battery cooling system. If the Vac-N-Fill Procedure is not used, the customer will return to the dealership with a low coolant condition. Refer to *Drive Motor Battery Cooling System Draining and Filling* in SI.
7. Use forklift to lift REMOVED high voltage battery from Lifting Table.
 8. Slowly lower REMOVED high voltage battery onto cribbing.
 9. Confirm battery is secure on cribbing.
 - Take almost all tension off the lifting straps and gently jostle high voltage battery to ensure stability.
 10. Detach lifting kit straps from eyebolts.
 11. Disconnect all six (pin/ bolt) assemblies from the high voltage battery and remove bolts/pins and lifting harness off of the high voltage battery.

Unloading Service High Voltage Battery from crate using FORKLIFT (If using Engine Hoist refer to Engine Hoist instructions.)

These crates are intended/rated for reuse and should be handled with care.–Do not expose the crate to rain, snow or any other environment that will cause moisture related damage.



5903435

Safety Recall

N212345946 High Voltage Battery May Melt or Burn



1. Inspect crate, all components for damage. If crate and components are found to be free from damage proceed to step 2. If crate and/or components are damaged, see end of closure instruction for contact information for replacement crate and/or components.



5903436

2. Remove (12) 1/2 inch hex head X 5/16 inch dia. x 4 inch lag screws. Place lag screws and washers in a separate container to be reused to close the crate once the removed high voltage battery is loaded.



5903437

3. Using lid handles, lift off the lid with (2) people.



5903438

4. Carefully set lid aside so as to not damage the foam on the inside of the crate lid.



5903439

5. Remove supplied items; 1 x gusseted poly bag, (1) 18 inch x 16 inch (46 x 41 cm) perforated absorbent pad, and 2 x absorbent pads, set these aside to be used for the return of the removed high voltage battery at a later step.

Safety Recall

N212345946 High Voltage Battery May Melt or Burn

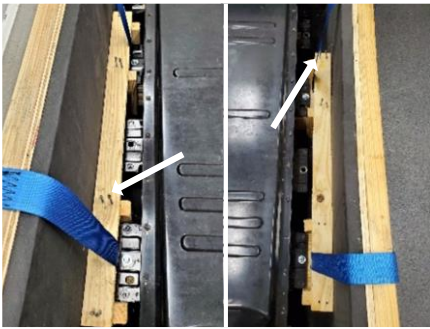

5903440

6. Using a T-20 or T-25 Torx bit (material shortages drove the need for either size) remove the 16 screws holding the 2 horizontal crossbars in place (save screws to re-secure in a future step).



5903441



5903442

7. Release (2) cinch straps and position along the outside of crate on both sides. Tuck straps under crate to avoid tripping hazard.



5903443

IMPORTANT: Lag screws will NOT be used when the removed high voltage battery is returned in the crate and can be discarded. DO NOT REUSE LAG SCREWS.

8. Remove all 4 lag screws securing the SERVICE high voltage battery in the crate and dispose of screws appropriately (2 on each side of the battery). Lag screws will NOT be used when the removed high voltage battery is returned in the crate-DO NOT REUSE LAG SCREWS.

Safety Recall

N212345946 High Voltage Battery May Melt or Burn

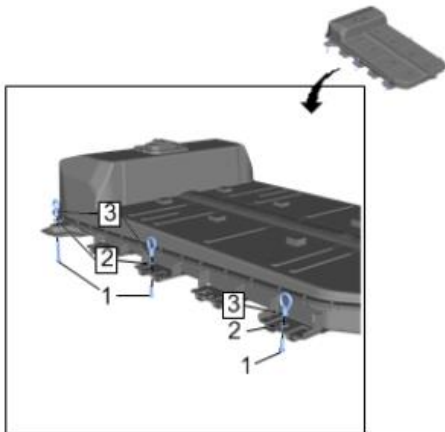

4587656

- Using the EL-51102–20 High Voltage Battery Lift Bar Tilter Eye-Nut Kit install the 3 eye-nut (3), washers (2) and bolts (1). The longer bolts should be used on the “heavy” side of the high voltage battery.

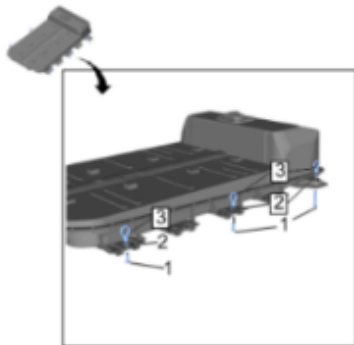

4587657

- Using the EL-51102–20 High Voltage Battery Lift Bar Tilter Eye-Nut Kit install the 3 eye-nut (3), washers (2) and bolts (1). The longer bolts should be used on the “heavy” side of the high voltage battery.
- Position the EL-51102 High Voltage Battery Lift Bar Tilter and EL-51102–10 Hanging Bars and Shackles (2) over the high voltage battery.
- Attach lift kit straps to eyebolts on SERVICE high voltage battery in crate.
 - Ensure Lifting Straps (4) attach the heavy end of the high voltage battery.
 - Adjust Tilter to bias the vertical bar about 8 inches (20 cm) from end with the handle.

Note: Make sure the drive motor battery is balanced when hung from the lifting straps before moving with a forklift (forks together with appropriate chain/attachment) to the Lifting Table.



5903444

- Carefully begin to raise the SERVICE high voltage battery out of the crate. Avoid contacting the foam lining of the crate with the high voltage battery. If foam is torn and cannot be repaired or reattached, it must be replaced.
- Move the crate away from the suspended high voltage battery. Move the lift table under the high voltage battery.
- Lower SERVICE high voltage battery onto Lift Table and confirm stability.
- Secure the SERVICE high voltage battery to the lifting table with straps.

Safety Recall

N212345946 High Voltage Battery May Melt or Burn



17. Detach lifting kit straps from eyebolts on SERVICE high voltage battery on Lifting Table.
18. Remove lifting kit eyebolts from SERVICE high voltage battery.
19. Remove coolant plugs from SERVICE high voltage battery -DO NOT DISCARD. Will be used with removed high voltage battery for shipping.
20. Remove MSD cover from the SERVICE high voltage battery -DO NOT DISCARD. Will be used with removed high voltage battery for shipping.
21. Remove High and Low Voltage Connector Covers from the SERVICE high voltage battery -DO NOT DISCARD. Will be used with removed high voltage battery for shipping.

High Voltage Battery Installation Procedure

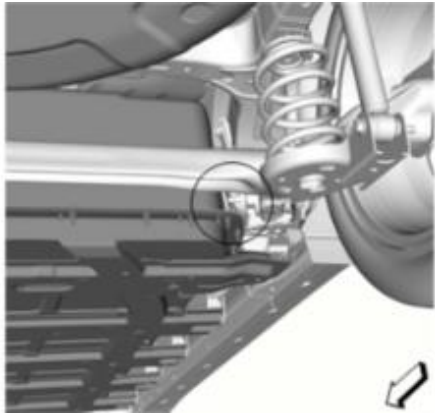

1. Avoid making contact between the rear of the drive motor battery and the rear suspension bushing bolts.



4587655

Warning: The GE-52200-50 lift table limiting chain is for use with GE-52200 lifting tables not equipped with a mechanical stop. Refer to the operating instructions provided with the limiting chain. Failure to limit uncontrolled descent of the lifting table may result in damage and/or serious injury.

2. With the drive motor battery (2) on the GE-52200 Lifting Table (1), slowly raise the lifting table.
3. Release the straps.
4. Continue to raise the battery into position for installation.

Safety Recall

N212345946 High Voltage Battery May Melt or Burn

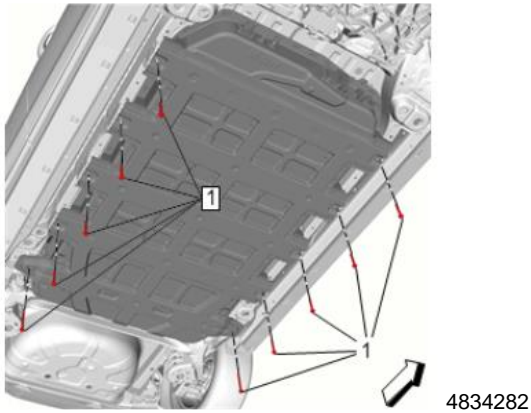

Caution: Refer to Fastener Caution in SI.

5. Snugly tighten the outside mounting fasteners (1).
6. Lower the lifting table.
7. Tighten the fasteners (1) to 56 Nm (41 lb. ft).

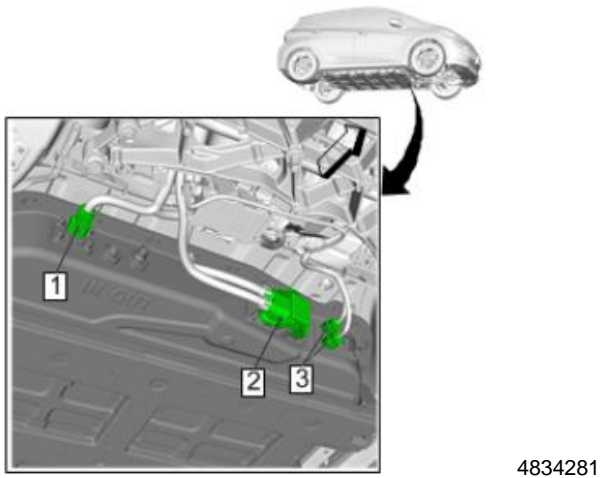

8. Connect the body wiring harness connectors (3) to the drive motor (high voltage) battery.
9. Connect the X3 high voltage connector (2) to the drive motor (high voltage) battery.
10. Connect the X4 high voltage connector (1) to the drive motor (high voltage) battery.

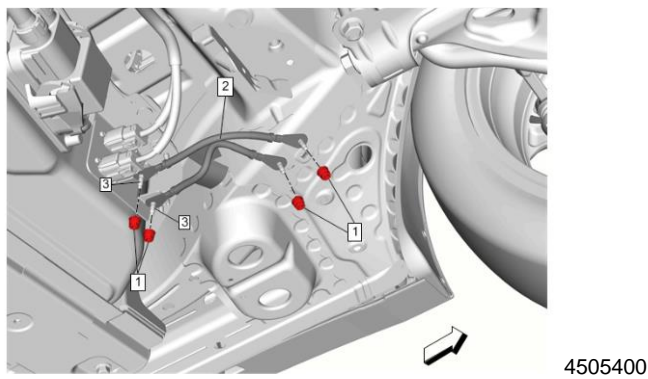

11. Install the battery negative cable (2) to the high voltage battery and body structure. Refer to *Battery Negative Cable Replacement* in SI.
12. Untie the straps that are installed to avoid the vehicle potentially falling off from the lift/hoist.

Safety Recall

N212345946 High Voltage Battery May Melt or Burn



13. Fill the drive motor battery cooling system. **The high voltage battery must be drained completely using the Vac-N-Fill Procedure before removal from the vehicle. Static draining is not sufficient. The Vac-N-Fill Procedure must also be used when refilling the drive motor battery cooling system. If the Vac-N-Fill Procedure is not used, the customer will return to the dealership with a low coolant condition.** Refer to *Drive Motor Battery Cooling System Draining and Filling* in SI.
 - 13.1. Disconnect the 12v battery after completing the coolant filling procedure.
14. Check the cooling system for leaks. Refer to *Hybrid Cooling System Leak Test* in SI.
15. Install the front compartment air deflector. Refer to *Front Compartment Air Deflector Replacement* in SI.
16. Enable the high voltage system. Refer to *High Voltage Enabling* in SI.
17. Reprogram the following modules.
 - a. Hybrid Powertrain Control Module 2. Refer to *K114B Hybrid/EV Powertrain Control Module 2: Programming and Setup* in SI.
 - i. Remain in the vehicle with the brake pedal depressed during the programming of the K114B HPCM2. When the green check mark indicates the K114B HPCM2 has been re-programmed, release the brake pedal and transition to Ignition ON/Propulsion OFF.
 - b. Battery Energy Control Module. Refer to *K16 Battery Energy Control Module: Programming and Setup* in SI.
 - c. All Model Years EXCEPT 2022 Body Control Module. Refer to *K9 Body Control Module: Programming and Setup* in SI.

Important: Be sure to complete the **Hybrid/EV Battery Pack Capacity Learn** and **EV Range Reset** following the steps in the Programming section below.

Programming

Note: Carefully read and follow the instructions below.

- Ensure the programming tool is equipped with the latest software and is securely connected to the data link connector. If there is an interruption during programming, programming failure or control module damage may occur.
- Stable battery voltage is critical during programming. Any fluctuation, spiking, over voltage or loss of voltage will interrupt programming. Install a GM Authorized Programming Support Tool to maintain system voltage. Refer to www.gmdesolutions.com for further information. If not available, connect a fully charged 12 V jumper or booster pack disconnected from the AC voltage supply. DO NOT connect a battery charger.
- Follow the on-screen prompts regarding ignition power mode but ensure that anything that drains excessive power (exterior lights, HVAC blower motor, etc.) is off.
- Clear DTCs after programming is complete. Clearing powertrain DTCs will set the Inspection/Maintenance (I/M) system status indicators to NO.

Important: The service technician always needs to verify that the VIN displayed in the TLC left side drop down menu and the top center window match the VIN plate of the vehicle to be programmed prior to using Service Programming System 2 (SPS2) for programming or reprogramming a module.

- For the TLC application, service technicians need to always ensure that the power mode (ignition) is "ON" before reading the VIN from the vehicle's VIN master module and that they do not select a VIN that is already in the TLC application memory from a previous vehicle.
- If the VIN that shows up in the TLC top center window after correctly reading the VIN from the vehicle does not match the VIN plate of the vehicle, manually type in the VIN characters from the vehicle VIN plate into the TLC top center window and use these for programming or reprogramming the subject module with the correct vehicle VIN and software and/or calibrations.

Caution: Be sure the VIN selected in the drop-down menu (1) is the same as the vehicle connected (2) before beginning programming.

Safety Recall

N212345946 High Voltage Battery May Melt or Burn

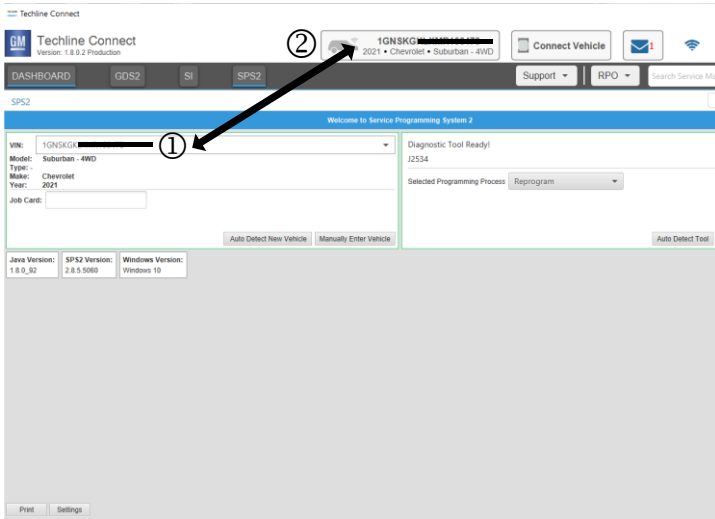

5743643

Important: If the vehicle VIN DOES NOT match, the message below will be shown.

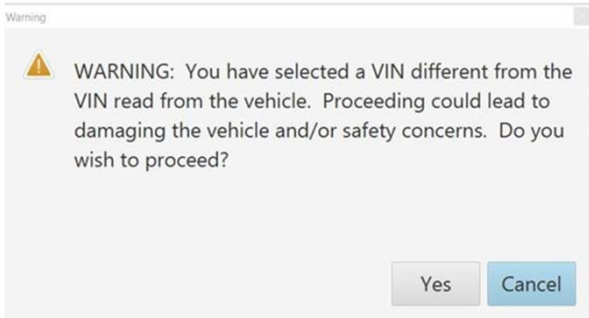

5877000

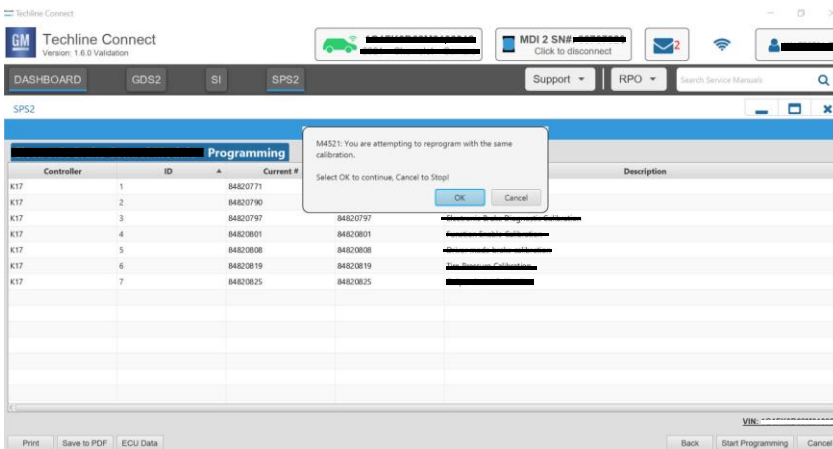

5644477

Safety Recall

N212345946 High Voltage Battery May Melt or Burn

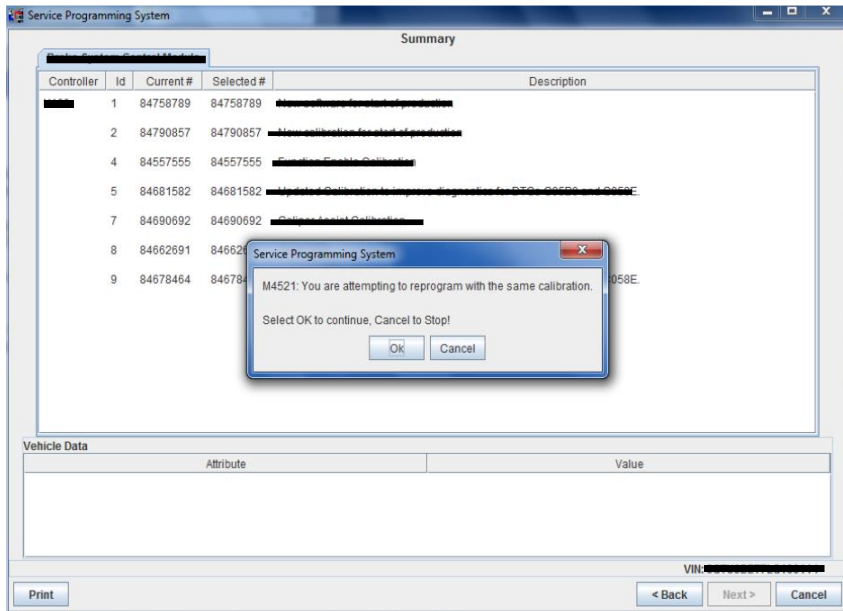

5431207

Important: Techline Connect and TIS2WEB screens shown above.

Important: If the same calibration/software warning is noted on the TLC or SPS Summary screen, select OK and follow screen instructions. After a successful programming event, the WCC is located in the Service Programming System dialogue box of the SPS Summary screen. No further action is required. Refer to the Warranty section of the bulletin.

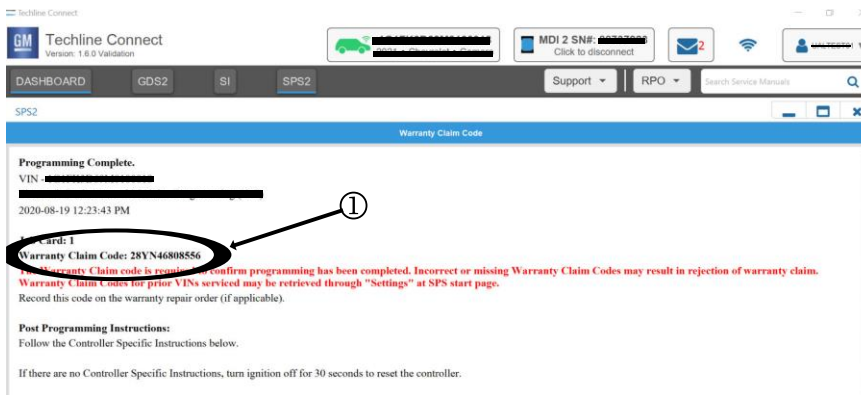

5644478

Safety Recall

N212345946 High Voltage Battery May Melt or Burn

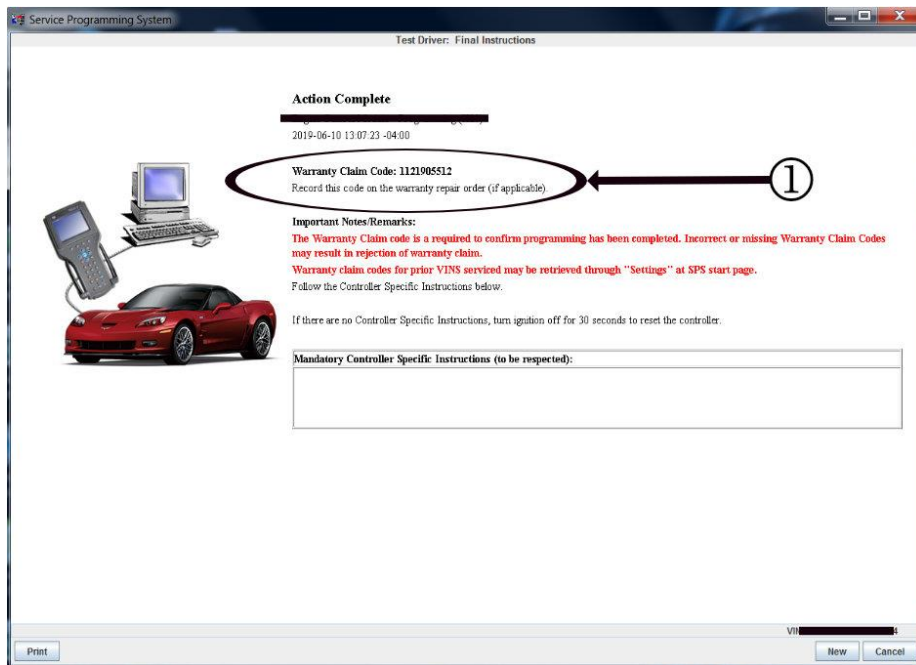

5431209

Note: The screenshots above are an example of module programming and may not be indicative of the specific module that is being programmed. Module selection and VIN information have been blacked out.

Important: To avoid warranty transaction rejections, you **MUST** record the warranty claim code provided on the Warranty Claim Code (WCC) screen shown above on the job card. Refer to callout 1 above for the location of the WCC on the screen.

1. Reprogram the following modules.
 - a. Hybrid Powertrain Control Module 2. Refer to K114B Hybrid/EV Powertrain Control Module 2: Programming and Setup in SI.
 - Remain in the vehicle with the brake pedal depressed during the programming of the K114B HPCM2. When the green check mark indicates the K114B HPCM2 has been re-programmed, as shown in the image, release the brake pedal and transition to Ignition ON/Propulsion OFF.
 - b. Battery Energy Control Module. Refer to K16 Battery Energy Control Module: Programming and Setup in SI.
 - c. (All Model Years Except 2022) Body Control Module. Refer to K9 Body Control Module: Programming and Setup in SI.
2. After programming has fully completed, clear DTCs. Let the vehicle sleep for 1 minute after removing the MDI, powering OFF, and closing all doors.

Hybrid/EV Range Reset

Perform the Hybrid/EV range reset using the steps below.

1. The Hybrid/EV range reset can be activated with a scan tool using the following steps:
 - 1.1. Vehicle on.
 - 1.2. With a scan tool, select Hybrid Powertrain Control Module 2.

Safety Recall

N212345946 High Voltage Battery May Melt or Burn

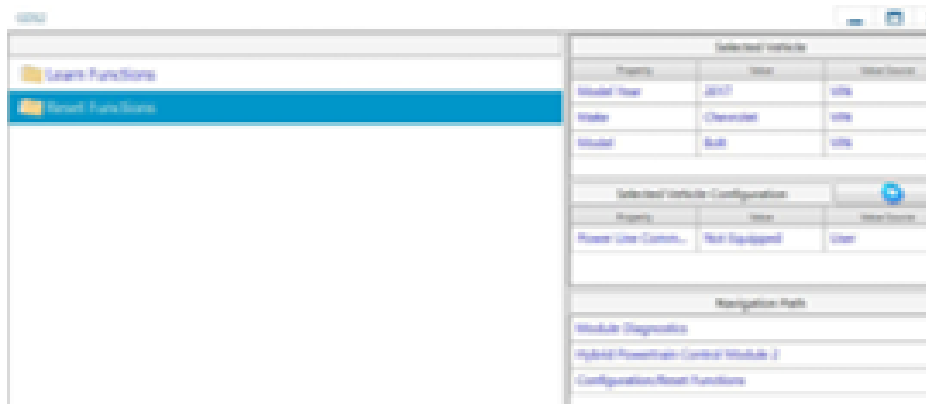

5882921

- 1.3. Select Hybrid Powertrain Control Module 2 Configuration/Reset Functions. Select the Reset Functions.



5882922

- 1.4. Using GDS2, reset the EV Range by selecting “EV Range Reset”.
2. Charge Vehicle to 80%.
3. Record SPS Warranty Claim Code AND the new replacement high voltage battery identification number on job card for warranty transaction submission. The high voltage battery identification number is located on the left side of the high voltage battery. The identification number contains the letters “RES” or “SNT” in the middle of the number.
4. Print the Customer Disclosure (located at the end of the Service Procedure) and place it in the glovebox.

Removed Battery Return Preparation

Danger: The high voltage battery must be protected when outside of the vehicle. The battery should be placed in the shipping crate from the service battery as soon as possible to avoid serious injury or death.

After the high voltage battery has been removed from the vehicle and before placement into the shipping crate, prepare the high voltage battery for return by performing the following steps:

1. Install the coolant plugs. There are 2 of them in the coolant lines. The coolant plugs were removed from the service high voltage battery assembly and must be installed in the removed high voltage battery. Additional coolant plugs (GM P/N 22770854) can be ordered if they are needed.

Note: The Drive Motor Battery High Voltage Manual Disconnect Lever is also known as the S15 Manual Service Disconnect (MSD).

2. Install the Manual Service Disconnect (MSD) Cover. The MSD cover was removed from the new service battery assembly and must be installed in the returned battery. The MSD lever must remain with the vehicle and not be returned with the removed high voltage battery.
3. Install the High and Low Voltage Connector Covers. The covers can be removed from the service high voltage battery and installed on the removed high voltage battery.

Safety Recall

N212345946 High Voltage Battery May Melt or Burn



Crating of REMOVED High Voltage Battery using FORKLIFT (If using Engine Hoist refer to Engine Hoist instructions).

Connect Lifting Kit to REMOVED High Voltage Battery

Follow technical specification to connect the GM approved Lifting Kit to the high voltage battery.

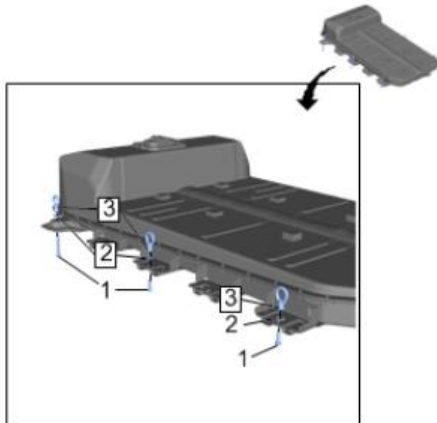

4587656

1. Using the EL-51102-20 High Voltage Battery Lift Bar Tilter Eye-Nut Kit install the 3 eye-nut (3), washers (2) and bolts (1). The longer bolts should be used on the “heavy” end of the high voltage battery.

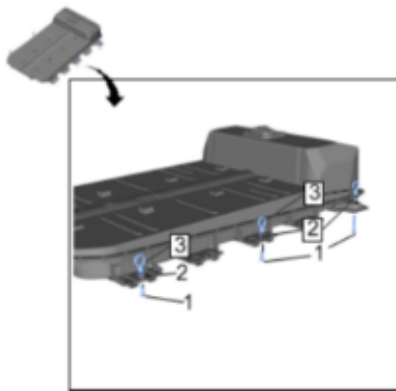

4587657

2. Using the EL-51102-20 High Voltage Battery Lift Bar Tilter Eye-Nut Kit install the 3 eye-nut (3), washers (2) and bolts (1). The longer bolts should be used on the “heavy” end of the high voltage battery.

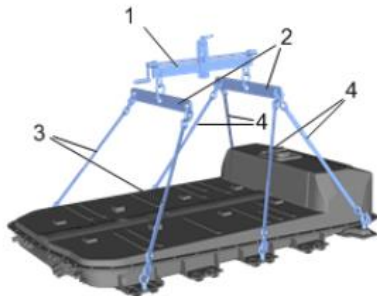

4587658

3. Attach lift kit straps to eyebolts on REMOVED high voltage battery.
 - Ensure Lifting Straps (4) attach the heavy end of the high voltage battery.
 - Adjust Tilter to bias the vertical bar about 8 inches from end with the handle.

Safety Recall

N212345946 High Voltage Battery May Melt or Burn



REMOVED High Voltage Battery Return Shipping Preparation using FORKLIFT (If using Engine Hoist refer to Engine Hoist instructions).



5903431

When lifting and moving the crate with the removed high voltage battery inside, be aware of the Center of Gravity (CG) as noted on the long sides of the crate. Fork mast should be centered with this mark and forks should be widened out to their maximum width and equally spaced on either side of the CG mark.

Important: The high voltage battery is regulated under dangerous goods transportation laws. As the shipper of record, dealers are responsible for compliance with all applicable international, federal, state, provincial, or local dangerous goods transportation laws. This includes, but is not limited to proper labeling, marking, completion of shipping papers, and packaging. Failure to comply with federal dangerous goods transportation laws may result in a violation of the U.S. Hazardous Materials Transportation Act, as amended, and its implementing regulations issued by the U.S. Department of Transportation at Title 49, Volumes 2-3, of the Code of Federal Regulations and could subject you to fines of up to \$84,425 for each violation, or criminal penalties. Similarly, in Canada, failure to comply with the Transportation of Dangerous Goods Act and Regulations may subject you to fines.

These crates are intended/rated for reuse and must be handled with care. Do not expose the crate to rain, snow or any other environment that will cause moisture related damage.

Replacement packing material for shipping:



5903430

- US dealers-If required, obtain replacement packaging materials through the SNT app in Global Connect (Same app used to order and return high voltage batteries).
- Canadian dealers- If required, obtain replacement packaging materials through YORK ELECTRONICS OSHAWA at 1-888-650-9675 ext. 307.
- **For Markets other than US and Canada, Refer to Field Action bulletin N212345942.**



5903442

1. Position the cinch straps over the edge of the crate and ensure buckles are outside the crate. Tuck any excess length of straps under the crate to avoid a tripping hazard.

Safety Recall

N212345946 High Voltage Battery May Melt or Burn



5903445

2. Return previously removed poly bag to crate. Open the gusseted poly bag and lay the seam of the bag along the center line of the crate floor.
 - a. The 81 inch (206 cm) length should be run along the long side of the crate.
 - b. The 58 inch (147 cm) length should run along the short side of the crate.
 - c. Carefully tuck polybag into the bottom of the crate. Ensure that polybag is pushed down into corners and touches inside of crate floor.

Important: Use extreme caution to ensure poly bag is NOT torn during this process. A torn poly bag will need to be replaced. See contact information at the end of the closure instructions for questions, or ordering replacement crate components.



5903446

3. Grab one (1) of previously removed absorbent pads and lay in bottom of crate on top of poly bag.



5903447

4. Align one edge with vertical wood supports. Fold over 12 inches (30 cm) of absorbent liner along the other side of the crate, all vertical supports should now be visible. This will help to ensure battery is properly seated in the crate.

Safety Recall

N212345946 High Voltage Battery May Melt or Burn

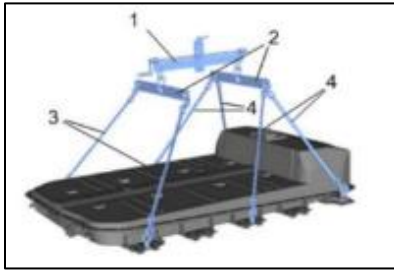

4587658

5. Follow technical specifications to connect the GM approved lift kit to the high voltage battery.



5903460



5903448

6. Ensure the heavy end of the high voltage battery is aligned to the end of the crate stenciled "heavy end". Ensure the crate and the forklift are squared up to one another.



5903449

7. Carefully lower the high voltage battery into the crate so as not to tear the bag or absorbent liner. Ensure the high voltage battery is leveled in the crate.

CAUTION: Ensure none of the high voltage battery "feet" are resting on any of the vertical supports. The high voltage battery feet need to be in between the vertical supports to avoid high voltage battery damage.

8. Confirm the following measurements to ensure high voltage battery is seated properly before proceeding.
 - At least 2 inches (5 cm) from top surface of #2 and #4 bars to top edge of vertical wood support (confirm at all 4 bars).
 - At least 16 inches (41 cm) from top surface of flange to top edge of crate at heavy end of high voltage battery.
 - At least 13 ½ inches (34 cm) from top surface of flange to top edge of crate at light end of high voltage battery.

Danger: Measurements need to be taken at all 6 locations to ensure fully seated. Failure to carefully follow these procedures may result in serious injury or death.

9. If these measurements are not met at ALL 6 locations the battery is not properly seated and should be lifted, repositioned using tag lines and lowered again.

Safety Recall

N212345946 High Voltage Battery May Melt or Burn



Danger: Measurements need to be retaken at all 6 locations to ensure fully seated. Failure to carefully follow these procedures may result in serious injury or death

Warning: If battery is not fully seated and meet the above measurements, the high voltage battery could shift when removing Lifting Strap Pin Bolts and hands/fingers could be crushed by weight of high voltage battery.

10. Once above measurements are taken and it is confirmed the high voltage battery is fully seated, disconnect lifting straps.

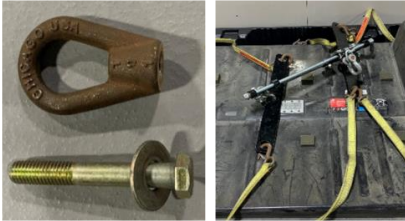

5903450

11. Disconnect all six (eyenut/bolt) assemblies from the high voltage battery. Remove eyenuts/bolts and lifting harness off of the high voltage battery and out of full cycle crate.



5903454

12. Open second absorbent pad, place on top of the high voltage battery as shown on the picture above, tuck the absorbent pad around the high voltage battery.



5903455

13. Fold the gusseted poly bag as follows:
 - a. Fold excess poly bag material on one short side of crate over end of high voltage battery.
 - b. Repeat for opposite short side of poly bag.



5903456

Safety Recall

N212345946 High Voltage Battery May Melt or Burn



14. Fold excess poly bag material along one of the long sides of crate across the side of high voltage battery. Repeat for the opposite long side of poly bag.



5903457

15. Loosely secure cinch straps and take the 18 inch x 16 inch (46 x 41 cm) perforated absorbent pad, tear at perforation and place 1 pad under each of the 2 buckles to prevent any chaffing, or tears on the poly bag. Pull 2 cinch straps tight.



5903458

Important: Be sure to install the 2 horizontal crossbars on each side of the crate to ensure Dangerous Goods Compliance.

16. Using the previously removed 16 x T20 or T25 Torx head screws, reattach (2) horizontal crossbars on each side of the crate. Do not over tighten. Screws should be flush with top surface of the crossbar.

Important: DO NOT reinstall original lag screws securing the battery. Use extreme caution to ensure the poly bag is not pierced or torn to ensure compliance with dangerous goods transportation laws.

Important: Place a copy of the repair order with the high voltage battery to be returned. Failure to return a copy of the repair order with the shipment may result in a debit.



5903460

17. Return the lid to top of crate lifting by the handles on the top of the lid, **ensure the HEAVY END on lid aligns with heavy end on the side of the crate**. Carefully attach the lid using the (12) 1/2 inch hex head x 5/16 inch dia. x 4 inch lag screws that were loosened when the new battery was removed from the crate. Do not apply more than the maximum torque of 84-117 in-lbs. (7 – 9.75 ft-lbs.) (.97 - 1.24 – kg-m).



5903461

Safety Recall

N212345946 High Voltage Battery May Melt or Burn



5903462

18. Reverse the (2), Class 9 labels to read Damaged / Defective (one on each side of the crate).
 - c. Open the three (3) release clips and reverse the labels to show UN3480 - DAMAGE / DEFECTIVE side.
 - d. Close the three (3) clips to secure the Class 9 label in place.

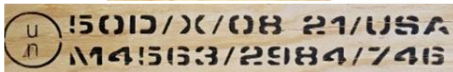

5903463

19. Do not stack loaded crates more than **3 high**. Maximum stacking weight 6,579 lbs. (2984kg). Ensure gross package weight does not exceed the UN specification mark on the package of 1645 lbs. (746 KG).

Caution: Be sure to set up temporary location for the removed battery until final shipping preparation. Do not expose the crate to rain, snow or any other environment that will cause moisture related damage.

Ensure that all legal requirements for shipment of this material have been met, including those applicable to you as the shipper of dangerous goods/hazardous materials.

Contact and Website Information

Important: For assistance with any dangerous goods relating to packaging or shipping information, please contact the Dangerous Goods and Container Question Hotline (English, Spanish and French) at:

- 1 (844) 931-4966
- Hours of Operation - Monday through Friday 8 a.m. – 5 p.m. US Central Standard Time.

Important: The high voltage battery is regulated under dangerous goods transportation laws. As the shipper of record, dealers are responsible for compliance with all applicable international, federal, state, provincial, or local dangerous goods transportation laws. This includes, but is not limited to proper labeling, marking, completion of shipping papers, and packaging. Failure to comply with federal dangerous goods transportation laws may result in a violation of the U.S. Hazardous Materials Transportation Act, as amended, and its implementing regulations issued by the U.S. Department of Transportation at Title 49, Volumes 2-3, of the Code of Federal Regulations and could subject you to fines of up to \$84,425 for each violation, or criminal penalties. Similarly, in Canada, failure to comply with the Transportation of Dangerous Goods Act and Regulations may subject you to fines.

Using Engine Hoist and Pallet Jack Method for Uncrating/Crating

Removal of Removed High Voltage Battery from Lifting Table using Engine Hoist

Connect Lifting Kit to Removed High Voltage Battery

Follow technical specification to connect the GM approved Lifting Kit to the high voltage battery.

Safety Recall

N212345946 High Voltage Battery May Melt or Burn

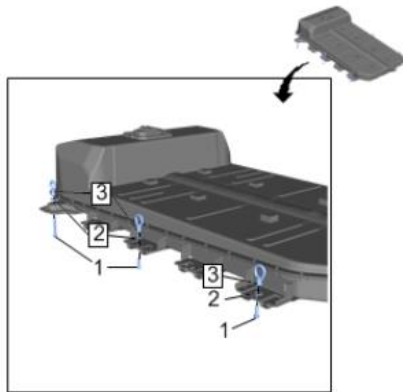

4587656

1. Using the EL-51102-20 High Voltage Battery Lift Bar Tilter Eye-Nut Kit install the 3 eye-nut (3), washers (2) and bolts (1). The longer bolts should be used on the “heavy” end of the high voltage battery.

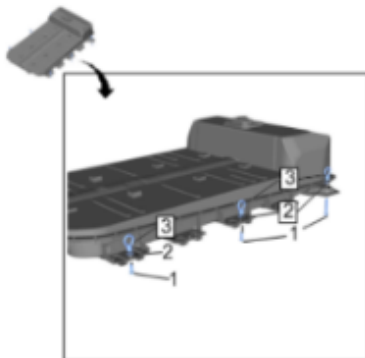

4587657

2. Using the EL-51102-20 High Voltage Battery Lift Bar Tilter Eye-Nut Kit install the 3 eye-nut (3), washers (2) and bolts (1). The longer bolts should be used on the “heavy” end of the high voltage battery.

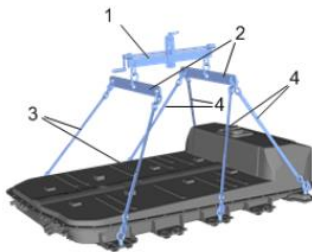

4587658

Assemble Lifting Kit

- EL-51102 High Voltage Battery Lift Bar Tilter (1)
 - EL-51102-10 Hanging Bars and Shackles (2)
 - EL-51102-40/50 Battery Lifting Strap (3) and (4)
3. Attach Lifting Kit to engine hoist with appropriate attachment.
 4. Move engine hoist to location where REMOVED high voltage battery will be staged (ensure sufficient spacing to remove Lifting Table and position Shipping crate).

Important: Make sure there is enough room between the crate, Lifting Table and engine hoist as the engine hoist with the battery attached CANNOT be moved.

Safety Recall

N212345946 High Voltage Battery May Melt or Burn



5. Move Lift Table with removed high voltage battery under engine hoist.
6. Attach lift kit straps to eyebolts on REMOVED high voltage battery on Lift Table.

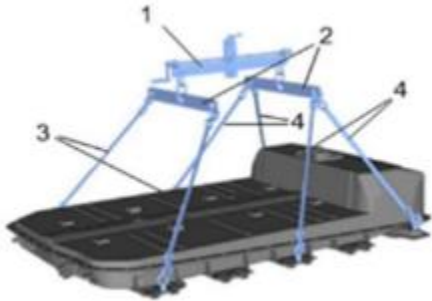

4587658

- Ensure Lifting Straps (4) attach the heavy end of the high voltage battery.
- Adjust Tilter to bias the vertical bar about 8 inches (20 cm) from end with the handle.

Note: Make sure the drive motor battery is balanced when hung from the lifting straps before lowering to the Lifting Table.

Note: As part of the high voltage battery removal process, all coolant should be drained from the high voltage battery. The high voltage battery must be drained completely using the Vac-N-Fill Procedure before removal from the vehicle. Static draining is not sufficient. The Vac-N-Fill Procedure must also be used when refilling the drive motor battery cooling system. If the Vac-N-Fill Procedure is not used, the customer will return to the dealership with a low coolant condition. Refer to *Drive Motor Battery Cooling System Draining and Filling* in SI.

7. Use Engine Hoist to lift removed high voltage battery from Lifting Table and then move Lifting Table out from under high voltage battery/hoist.

Danger: To avoid serious injury or death, follow the instructions below:

- DO NOT MOVE THE ENGINE HOIST WITH THE HIGH VOLTAGE BATTERY ATTACHED.
- DO NOT go under the engine hoist with the high voltage battery attached.
- DO NOT maneuver the high voltage battery with the Lifting Kit straps.



5903432



5903803

Safety Recall

N212345946 High Voltage Battery May Melt or Burn



8. Set-up cribbing under Hoist & high voltage battery to place REMOVED high voltage battery on from the Lifting Table.
 - Set-up jack stands and two (2) 4x4s 27 inches (69 cm) apart (inside measurement) to allow battery frame to sit on 4x4s. Jack stands should be placed at outer edge of high voltage battery at bar location (1) and (5) as shown above.

Caution: DO NOT place high voltage battery directly on ground or directly on jack stands without 4x4s to avoid high voltage battery damage.

9. Slowly lower REMOVED high voltage battery onto cribbing.
10. Confirm high voltage battery is secure on cribbing.
 - Take almost all tension off the lifting straps and gently jostle high voltage battery to ensure stability.
11. Detach lifting kit straps from eyebolts (leave lifting kit attached to Hoist) and move hoist.

Unloading SERVICE High Voltage Battery from Crate using Engine Hoist



5903435

1. Inspect crate, all components for damage. If crate and components are found to be free from damage proceed to Step 2. If crate and/or components are damaged, see end of closure instruction for contact information.



5903436

2. Remove (12) 1/2 inch hex head X 5/16 inch dia. x 4 inch lag screws. Place lag screws and washers in a separate container to be reused to close the crate once the removed high voltage battery is loaded.



5903437

3. Using lid handles, lift off the lid with (2) people.



5903438

4. Carefully set lid aside so as to not damage the foam on the inside of the crate lid.

Safety Recall

N212345946 High Voltage Battery May Melt or Burn



5903439

5. Remove supplied items; 1 x gusseted poly bag, (1) 18 inch x 16 inch (46 x 41 cm) perforated absorbent pad, and 2 x absorbent pads. Set these aside to be used for the return of the removed high voltage battery at a later step.

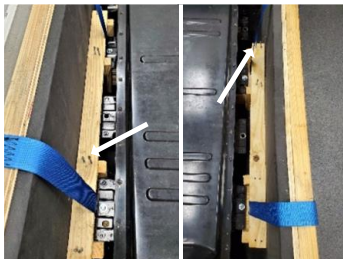

5903440

6. Using a T-20 or T-25 Torx bit (material shortages drove the need for either size) remove the 16 screws holding the 2 horizontal crossbars in place (save screws to re-secure in a future step).



5903441



5903442

7. Release (2) cinch straps and position along the outside of crate on both sides. Tuck straps under crate to avoid tripping hazard.

Safety Recall

N212345946 High Voltage Battery May Melt or Burn



5903443

Important: Lag screws will NOT be used when the removed high voltage battery is returned in the crate and can be discarded. DO NOT REUSE LAG SCREWS.

8. Remove all 4 lag screws securing the high voltage battery in the crate and dispose of screws appropriately (2 on each side of the high voltage battery). Lag screws will NOT be used when the removed high voltage battery is returned in the crate-DO NOT REUSE LAG SCREWS.

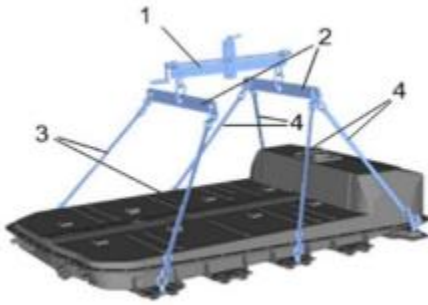

4587658

9. Remove lifting kit eyebolts from REMOVED high voltage battery and install on SERVICE high voltage battery (connect to the #1, #3, and #5 bars on the high voltage battery).



5903444

10. Measure clearance needed for engine hoist legs to fit under the crate (instruction below are for 8 inch clearance, adjust appropriately for hoist leg clearance).
11. Crib the crate & pallet jack.
 - 11.1. Use pallet jack to raise crate ~4-5 inches (10-13 cm) and place 4x4 ~60 inch (152 cm) under each runner at ends of crate and lower crate so crate runners rest on 4x4s.
 - 11.2. Put two 4x4s (~36 inch length) (91 cm) on pallet jack forks.
 - 11.3. Raise crate using pallet jack (w/4x4s on it) to raise crate additional 2-3 inches (5-8 cm) and place 2x4 on existing 4x4 under each runner at ends of crate and lower crate so runners rest on the 2x4s.
12. Verify engine hoist clearance is met.
13. Position engine hoist over crate with lifting kit attached.

Safety Recall

N212345946 High Voltage Battery May Melt or Burn

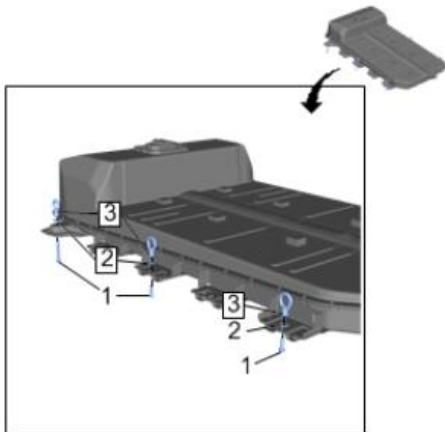

4587656

14. Using the EL-51102–20 High Voltage Battery Lift Bar Tilter Eye-Nut Kit install the 3 eye-nut (3), washers (2) and bolts (1). The longer bolts should be used on the “heavy” side of the high voltage battery.

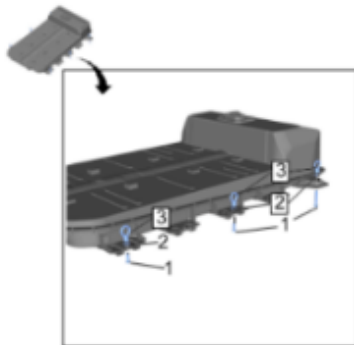

4587657

15. Using the EL-51102–20 High Voltage Battery Lift Bar Tilter Eye-Nut Kit install the 3 eye-nut (3), washers (2) and bolts (1). The longer bolts should be used on the “heavy” side of the high voltage battery.
16. Position the EL-51102 High Voltage Battery Lift Bar Tilter and EL-51102–10 Hanging Bars and Shackles (2) over the high voltage battery.
17. Attach lift kit straps to eyebolts on SERVICE high voltage battery in crate.
18. Ensure Lifting Straps (4) attach the heavy end of the high voltage battery.
19. Adjust Tilter to bias the vertical bar about 8 inches (20 cm) from end with the handle.



5903444

20. Carefully begin to raise the SERVICE high voltage battery out of the crate. Avoid contacting the foam lining of the crate with the battery. If foam is torn and cannot be repaired or reattached, it must be replaced.

Warning: To avoid serious injury, DO NOT MOVE THE ENGINE HOIST WITH THE HIGH VOLTAGE BATTERY ATTACHED.

21. Using a pallet jack, move the empty crate away from engine hoist (move crate cribbing also being sure to maintain stability).
22. Position lift table under SERVICE high voltage battery.
23. Lower SERVICE high voltage battery onto Lift Table and confirm stability.

Safety Recall

N212345946 High Voltage Battery May Melt or Burn



24. Secure the high voltage battery to the lifting table with straps.
25. Detach lifting kit straps from eyebolts on SERVICE high voltage battery on table.
26. Remove lifting kit eyebolts from SERVICE high voltage battery.
27. Remove coolant plugs from SERVICE high voltage battery-DO NOT DISCARD. Will be used with removed high voltage battery for shipping.
28. Remove MSD cover from the SERVICE high voltage battery -DO NOT DISCARD. Will be used with removed high voltage battery for shipping.
29. Remove High and Low Voltage Connector Covers from the SERVICE high voltage battery-DO NOT DISCARD. Will be used with removed high voltage battery for shipping.
30. Install SERVICE high voltage battery in vehicle from table. Refer to *Drive Motor Battery Replacement and Shipping Preparation*.

REMOVED High Voltage Battery Return Shipping Preparation using Engine Hoist

After the high voltage battery has been removed from the vehicle and before placement into the shipping crate, prepare the high voltage battery for return by performing the following steps:

1. Install the coolant plugs. There are 2 of them in the coolant lines. The coolant plugs can be removed from the new SERVICE high voltage battery assembly and installed in the returned high voltage battery. Additional coolant plugs (GM P/N 22770854) can be ordered if they are needed.

Note: The Drive Motor Battery High Voltage Manual Disconnect Lever is also known as the S15 Manual Service Disconnect (MSD).

2. Install the Manual Service Disconnect (MSD) Cover. The MSD cover can be removed from the new SERVICE high voltage battery assembly and installed in the removed high voltage battery. The MSD lever should remain with the vehicle and not be returned with the removed high voltage battery assembly.
3. Install the High and Low Voltage Connector Covers. The covers can be removed from the SERVICE high voltage battery and installed on the removed battery.

Final Shipping Preparation

Replacement packing material for shipping:



5903430

- US dealers-If required, obtain replacement packaging materials through the SNT app in Global Connect (Same app used to order and return batteries).
- Canadian dealers- If required, obtain replacement packaging materials through YORK ELECTRONICS OSHAWA at 1-888-650-9675 ext. 307.
- For Markets other than US and Canada, Refer to Field Action bulletin N212345942.



5903431

When lifting and moving the crate with the high voltage battery inside, be aware of the Center of Gravity (CG) as noted on the long sides of the crate. Fork mast should be centered with this mark and forks should be widened out to their maximum width and equally spaced on either side of the CG mark.

Packing/Closure Instructions for Full Cycle Crate for DDR Battery Returns Using Engine Hoist

Safety Recall

N212345946 High Voltage Battery May Melt or Burn



Loose crate components to support return of DDR battery:

- 1 – 81 inch (206cm) x 58 inch (148cm) x 96 inch (244cm) gusseted poly bag
- 2 – 57 inch (145cm) x 80 inch (203cm) absorbent poly bags
- 1 – 18 inch (46cm) x 16 inch (41cm) perforated absorbent pad

IMPORTANT: The high voltage battery is regulated under dangerous goods transportation laws. As the shipper of record, dealers are responsible for compliance with all applicable international, federal, state, provincial, or local dangerous goods transportation laws. This includes, but is not limited to proper labeling, marking, completion of shipping papers, and packaging. Failure to comply with federal dangerous goods transportation laws may result in a violation of the U.S. Hazardous Materials Transportation Act, as amended, and its implementing regulations issued by the U.S. DOT at Title 49, Volumes 2-3, of the CFR and could subject you to fines of up to \$84,425 for each violation, except the maximum fine is \$196,992 if the violation results in death, serious illness, or severe injury to any person or substantial destruction of property. Failure to follow these closure instructions may result in a violation of the U.S. Hazardous Materials Transportation Act and could subject you to fines as previously referenced.

The packaging referenced has passed the standards of the DOT'S TITLE 49 CFR; Performance Oriented Packaging Standards, Section 178. This package is also certified under ADR, IMDG, ICAO/IATA Regulations and the UN Recommendations on the Transport of Dangerous Goods. It is the responsibility of the end user to determine authorization for use under these regulations. The use of other packaging methods or components other than those documented in this report may render this certification invalid.

These crates are intended/rated for reuse and must be handled with care. Do not expose the crate to rain, snow or any other environment that will cause moisture related damage.

After the SERVICE high voltage battery has been removed, inspect crate, and all components for damage. If crate is found to be free from damage proceed to next step. If crate is damaged, contact Labelmaster for guidance and or replacement parts. Labelmaster contact information is at the bottom of this instruction sheet.



5903442

1. Position the cinch straps over the edge of the crate and ensure buckles are outside the crate. Tuck any excess length of straps under the crate to avoid a tripping hazard.



5903445

2. Return previously removed poly bag to crate. Open the gusseted poly bag and lay the seam of the bag along the center line of the crate floor.
 - 2.1. The 81 inch (206 cm) length should be run along the long side of the crate.
 - 2.2. The 58 inch (147 cm) length should run along the short side of the crate.

Safety Recall

N212345946 High Voltage Battery May Melt or Burn



- 2.3. Carefully tuck poly bag into the bottom of the crate. Ensure that poly bag is pushed down into corners and touches inside of crate floor.

Important: Use extreme caution to ensure poly bag is NOT torn during this process. A torn poly bag will need to be replaced. See contact information at the end of the closure instructions for questions, or ordering replacement crate components.



5903446

3. Grab one (1) of previously removed absorbent pads and lay in bottom of crate on top of poly bag.



5903447

4. Align one edge with vertical wood supports. Fold over 12 inches (30 cm) of absorbent liner along the other side of the crate, all vertical supports should now be visible. This will help to ensure high voltage battery is properly seated in the crate.
5. Move engine hoist so it is positioned over removed high voltage battery.

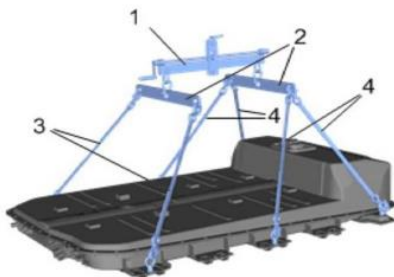

4587658

6. Follow technical specifications to connect the GM approved lift kit to the high voltage battery.
7. Lift removed high voltage battery from jack stand cribbing then move cribbing out of the way.
8. Position and crib the crate & pallet jack under removed high voltage battery hanging on hoist.
 - 8.1. Use pallet jack to raise crate ~4-5 inches (10-13 cm) and place 4x4 ~ 60 inches (152 cm) under each runner at ends of crate and lower crate so crate runners rest on 4x4s.

Safety Recall

N212345946 High Voltage Battery May Melt or Burn



- 8.2. Put two 4x4s (~36 inch length) (91 cm) on pallet jack forks.
- 8.3. Raise crate using pallet jack (w/4x4s on it) to raise crate additional 2-3 inches (5-8 cm) and place 2x4 on existing 4x4 under each runner at ends of crate and lower crate so runners rest on the 2x4s.
9. Confirm crate, with poly bag in place, is aligned appropriately under the high voltage battery on the engine hoist.
10. Ensure the heavy end of the high voltage battery is aligned to the end of the crate stenciled "heavy end". Ensure the crate and the fork truck /or engine hoist are squared up to one another.



5903448



5903449

11. Carefully lower the high voltage battery into the crate so as not to tear the poly bag or absorbent liner. Ensure the high voltage battery is leveled in the crate.
12. Confirm the following measurements to ensure high voltage battery is seated properly before proceeding.
 - At least 2 inches (5 cm) from top surface of #2 and #4 bars to top edge of vertical wood support (confirm at all 4 bars).
 - At least 16 inches (41 cm) from top surface of flange to top edge of crate at heavy end of high voltage battery.
 - At least 13 ½ inches (34 cm) from top surface of flange to top edge of crate at light end of high voltage battery.

Danger: Measurements need to be taken at all 6 locations to ensure fully seated. Failure to carefully follow these procedures may result in serious injury or death.

13. If these measurements are not met at ALL 6 locations the high voltage battery is not properly seated and should be lifted, repositioned using tag lines and lowered again.

Danger: Measurements need to be retaken at all 6 locations to ensure fully seated. Failure to carefully follow these procedures may result in serious injury or death.

14. Once above measurements are taken and it is confirmed the high voltage battery is fully seated, disconnect lifting straps.

CAUTION: Ensure none of the high voltage battery "feet" are resting on any of the vertical supports to avoid high voltage battery damage.

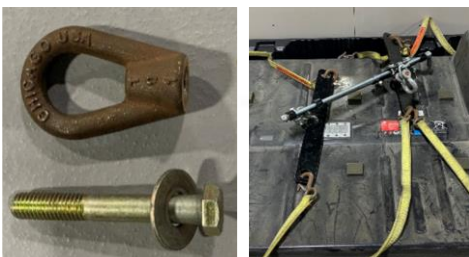

5903450

Safety Recall

N212345946 High Voltage Battery May Melt or Burn



15. Once the high voltage battery is safely lowered into the crate, disconnect all six (eyenuts/bolts) assemblies from the high voltage battery. Remove eyenuts/bolts and lifting harness off of the high voltage battery and out of full cycle crate.



5903454

16. Open a second absorbent pad, place on top of the high voltage battery as shown on the picture below, tuck the absorbent pad around the high voltage battery.



5903455

17. Fold the gusseted poly bag as follows:
 - a. Fold excess poly bag material on one short side of crate over end of high voltage battery.
 - b. Repeat for opposite short side of poly bag.



5903456

18. Fold excess poly bag material one of the long sides of crate across side of high voltage battery. Repeat for the opposite long side of poly bag.

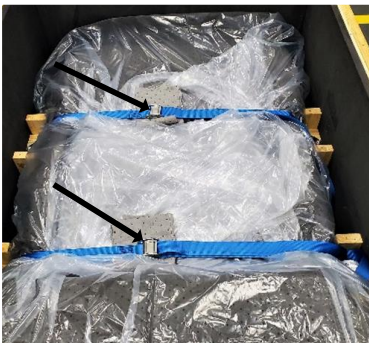

5903457

Safety Recall

N212345946 High Voltage Battery May Melt or Burn



- Loosely secure cinch straps take the 18 inch x 16 inch (46 x 41 cm) perforated absorbent pad, tear at perforation and place (1) pad under each of the (2) buckles to prevent any chaffing, or tears on the poly bag. Pull (2) cinch straps tight.



5903458

- Using the previously removed 16 x T20 or T25 Torx head screws, reattach (2) horizontal crossbars on each side of the crate. Do not over tighten. Screws should be flush with top surface of the crossbar.

Important: DO NOT reinstall original lag screws securing the battery. Use extreme caution to ensure the poly bag is not pierced or torn to ensure compliance with dangerous goods transportation laws.

Important: Place a copy of the repair order with the high voltage battery to be returned. Failure to return a copy of the repair order with the shipment may result in a debit.



5903460

- Return the lid to top of crate lifting by the handles on the top of the lid, **ensure the HEAVY END on lid aligns with heavy end on the side of the crate**. Carefully attach the lid using the (12) 1/2 inch hex head x 5/16 inch dia. x 4 inch lag screws that were loosened when the new battery was removed from the crate. Do not apply more than the maximum torque of 84-117 in-lbs. (7 – 9.75 ft-lbs.) (.97 - 1.24 – kg-m).



5903461



5903462

Safety Recall

N212345946 High Voltage Battery May Melt or Burn



22. Reverse the (2), Class 9 panels to read Damaged / Defective (one on each side of the crate).
23. Open the three (3) release clips and reverse the panel to show UN3480 - DAMAGE / DEFECTIVE side.
24. Close the three (3) clips to secure the panel in place.



25. **Do** not stack loaded crates more than 3 high. Maximum stacking weight 6,579 lbs. (2984kg). Ensure gross package weight does not exceed the UN specification mark on the package of 1645 lbs. (746 KG).

Important: Be sure to set up temporary location for the removed battery until final shipping preparation. Do not expose the crate to rain, snow or any other environment that will cause moisture related damage.

Ensure that all legal requirements for shipment of this material have been met, including those applicable to you as the shipper of dangerous goods/hazardous materials.

Contact and Website Information

Important: For assistance with any dangerous goods relating to packaging or shipping information, please contact the Dangerous Goods and Container Question Hotline (English, Spanish and French) at:

- 1 (844) 931-4966
- Hours of Operation - Monday through Friday 8 a.m. – 5 p.m. US Central Standard Time.

Important: The high voltage battery is regulated under dangerous goods transportation laws. As the shipper of record, dealers are responsible for compliance with all applicable international, federal, state, provincial, or local dangerous goods transportation laws. This includes, but is not limited to proper labeling, marking, completion of shipping papers, and packaging. Failure to comply with federal dangerous goods transportation laws may result in a violation of the U.S. Hazardous Materials Transportation Act, as amended, and its implementing regulations issued by the U.S. Department of Transportation at Title 49, Volumes 2-3, of the Code of Federal Regulations and could subject you to fines of up to \$84,425 for each violation, or criminal penalties.

Safety Recall

N212345946 High Voltage Battery May Melt or Burn



NOTICE TO CUSTOMER

This vehicle is now updated with a new advanced diagnostic software and a requalified battery that will continually monitor the high voltage battery performance. If the software detects a problem in your vehicle's high voltage battery, you will be alerted via a warning in the driver information center. If this occurs, you should contact your Chevrolet Bolt EV/EUV certified dealer.

The software will initially limit your vehicle's high voltage battery to a maximum state-of-charge of 80%. If no anomalies are detected after **approximately** 6,200 miles of use, the high voltage battery will automatically return to a maximum state-of-charge of 100% without a return trip to the dealer. After this occurs, the software's advanced diagnostics will continue to monitor your vehicle's high voltage battery system.

Your vehicle's current mileage is

_____miles

Your vehicle's high voltage battery will return to a maximum 100% state of charge at

approximately _____ miles

Please retain a copy of this notice in the vehicle's glove compartment. If you sell this vehicle, you **MUST** provide this notice to the buyer of your vehicle.

If you have any questions or concerns that your dealer is unable to resolve, please contact the EV Concierge at 1-833-EVCHEVY (1-833-382-4389) (TTY 711 / 1-800-833-2438).

For the hearing or speech impaired, please contact our Customer Assistance Center using the Telecommunication Relay Service by dialing 711 then providing the appropriate Customer Assistance Center number for your vehicle.

Hours of operation: Monday to Friday (8:00am to 9:00pm) & Saturday (8:00am to 5:00pm) ET.

GM Recall: N212345946

6570380

Dealer Responsibility – For USA & Export (USA States, Territories, and Possessions)

It is a violation of Federal law for a dealer to deliver a new motor vehicle or any new or used item of motor vehicle equipment (including a tire) covered by this notification under a sale or lease until the defect or noncompliance is remedied.

The US National Traffic and Motor Vehicle Safety Act provides that each vehicle that is subject to a recall of this type must be adequately repaired within a reasonable time after the customer has tendered it for repair. A failure to repair within sixty days after tender of a vehicle is prima facie evidence of failure to repair within a reasonable time. If the condition is not adequately repaired within a reasonable time, the customer may be entitled to an identical or reasonably equivalent vehicle at no charge or to a refund of the purchase price less a reasonable allowance for depreciation. To avoid having to provide these burdensome remedies, every effort must be made to promptly schedule an appointment with each customer and to repair their vehicle as soon as possible. In the recall notification letters, customers are told how to contact the US National Highway Traffic Safety Administration if the recall is not completed within a reasonable time.

Dealer Responsibility – All

All new, used, GM Certified Pre-Owned (CPO), courtesy transportation vehicles, dealer shuttle vehicles, CarBravo, etc. in dealers' possession and subject to this recall must be held and inspected/repared per the service procedure of this

Safety Recall

N212345946 High Voltage Battery May Melt or Burn



bulletin before customers take possession of these vehicles. Involved vehicles must be held and not delivered to customers, dealer-traded, released to auction, used for demonstration, or any other purpose.

All GM Certified Pre-Owned (CPO) vehicles currently in the dealers' inventory within the SHIFT Digital system will be de-certified and must be held and remedied per the service procedure in this bulletin. Upon submitting an accepted/paid warranty transaction in the Global Warranty Management (GWM) system, the vehicle can be re-certified for sale within the SHIFT Digital system, or once again be used in the Courtesy Transportation Program.

Dealers are to service all vehicles subject to this recall at no charge to customers, regardless of mileage, age of vehicle, or ownership, from this time forward.

Customers who have recently purchased vehicles sold from your vehicle inventory, and for which there is no customer information indicated on the dealer listing, are to be contacted by the dealer. Arrangements are to be made to make the required correction according to the instructions contained in this bulletin. Recall follow-up cards should not be used for this purpose, since the customer may not as yet have received the notification letter.

In summary, whenever a vehicle subject to this recall enters your vehicle inventory you must take the steps necessary to ensure the program correction has been made before selling the vehicle. In addition, for vehicles entering your facility for service, you are required to ensure the customer is aware of the open recall and make every reasonable effort to implement the program correction as set forth in this bulletin prior to releasing the vehicle.

Dealer Reports – For USA & Export

For dealers with involved vehicles, a listing has been prepared and will be available through GM GlobalConnect Maxis Field Action Reports or sent directly to export dealers. The Inventory tab of the dealer reports will contain VINs that apply to this recall. This information is intended to assist dealers with the **PROMPT COMPLETION** of these vehicles. The Customer In-Service tab will contain customer names and addresses from Motor Vehicle Registration Records. The use of such motor vehicle registration data for any purpose other than follow-up necessary to complete this recall may be a violation of law in several states.

GM bulletins are intended for use by professional technicians, NOT a "do-it-yourselfer". They are written to inform these technicians of conditions that may occur on some vehicles, or to provide information that could assist in the proper service of a vehicle. Properly trained technicians have the tools, equipment, safety instructions, and know-how to do a job properly and safely. If a condition is described, **DO NOT** assume that the bulletin applies to your vehicle, or that your vehicle will have that condition. See your dealer for information on whether your vehicle may benefit from the information.



**We Support
Voluntary Technician
Certification**