



May 2022

Dealer Service Instructions for:

## **Safety Recall Y55 / NHTSA 21V-632 Side Air Bag Inflatable Curtain Inflator**

**NOTE: Currently the remedy is available for 2015 model year vehicles ONLY. You will be notified at a later time once remedy becomes available for 2016 model year vehicles.**

### **Remedy Available**

**2015 (DS) Ram 1500 Pickup**  
**2015 (DJ) Ram 2500 Pickup**  
**2015 (D2) Ram 3500 Pickup**

### **Remedy NOT Available**

**2016 (DS) Ram 1500 Pickup**  
**2016 (DJ) Ram 2500 Pickup**  
**2016 (D2) Ram 3500 Pickup**  
**2016 (DF) Ram 3500 10K LB Cab Chassis**

***NOTE: Some vehicles above may have been identified as not involved in this recall and therefore have been excluded from this recall.***

**IMPORTANT: Some of the involved vehicles may be in dealer used vehicle inventory. Dealers should complete this recall service on these vehicles before retail delivery.** Dealers should also perform this recall on vehicles in for service. Involved vehicles can be determined by using the VIP inquiry process.

**Subject**

The Side Air Bag Inflatable Curtain (SABIC) inflator on about 184,950 of the above vehicles may rupture. A SABIC inflator rupture may result in compressed gas rapidly escaping from the inflator and material potentially being propelled into the vehicle. Material being propelled into the vehicle may cause injury to vehicle occupants.

**Repair**

Replace both SABICs. The SABICs for each vehicle are VIN specific and can be determined by using GRS or VIP as described in the Parts Information section below.

**Alternate Transportation**

Dealers should attempt to minimize customer inconvenience by placing the owner in a loaner vehicle if the vehicle must be held overnight.

**Parts Information**

**VIN specific parts application is available through the Global Recall System (GRS) and Vehicle Information Plus (VIP).**

To use GRS, enter DealerCONNECT, click on the “**Service**” tab, click on “**Global Recall System**,” enter the **recall number** in the “Recall Code:” box, and select “**VIN**” in the “**List By:**” drop down menu.

To use VIP, enter DealerCONNECT, click on the “**Service**” tab, click on “**Single VIN Inquiry**,” enter the **VIN and mileage**, click “**View**,” then click on the “**Coverages**” tab and view the “**Recall**” section.

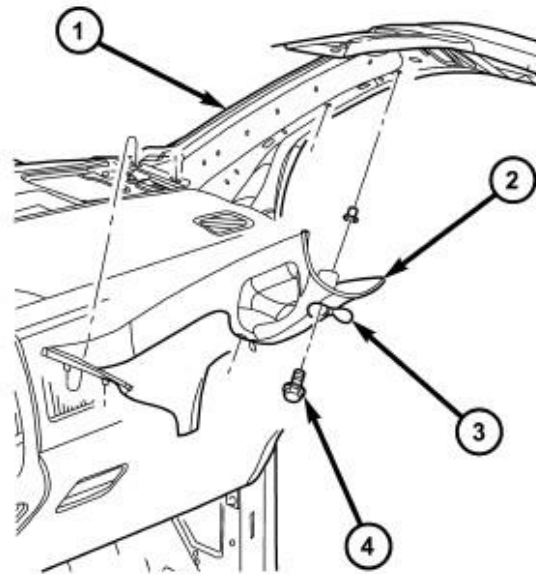
**Required parts should be ordered through DealerConnect Parts Order. Parts will be on a managed allocation restriction.**



**Service Procedure [Continued]**

**A. Standard Cab**

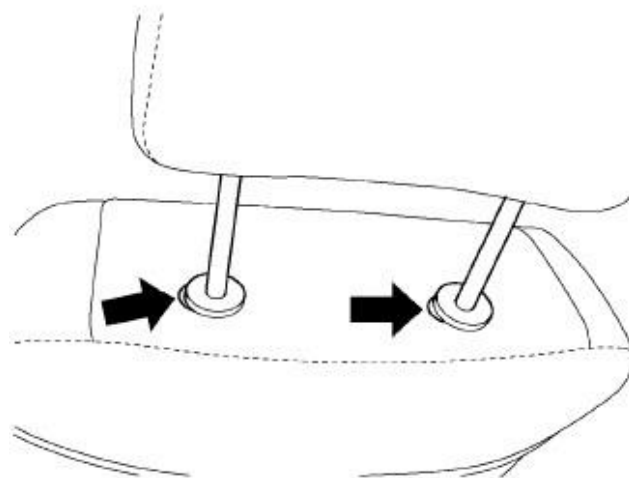
1. Using a small flat-bladed tool, carefully open the two fastener covers (3) located in the A-pillar trim panel (2) (Figure 1).
  
2. Remove the two bolts (4) that secure the A-pillar trim panel to the A-pillar (1) and remove the trim panel (Figure 1).



80d407a9

**Figure 1 – A-Pillar**

3. Push in the buttons on front seat headrest sleeves then pull the headrest up and remove (Figure 2).



8120dd43

**Figure 2 – Front Seat Head Rest**

4. Fold the seats forward.

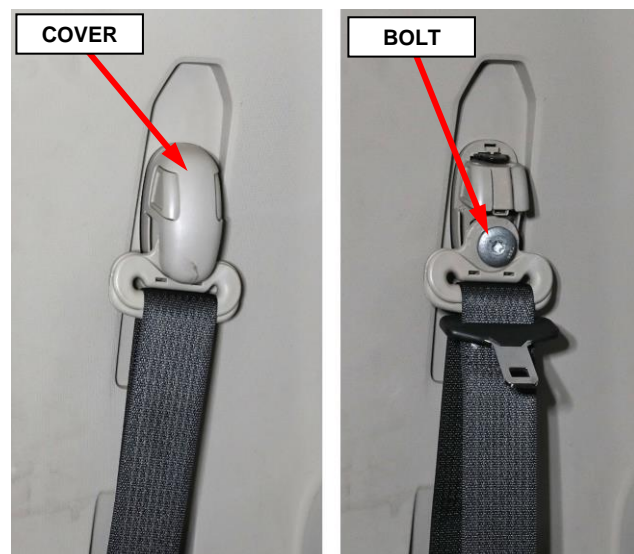
**Service Procedure [Continued]**

5. Release the upper retaining clips of the B-pillar lower trim panel to allow for removal of the B-pillar upper trim panel (Figure 3).



**Figure 3 – B-Pillar Lower Trim Panel**

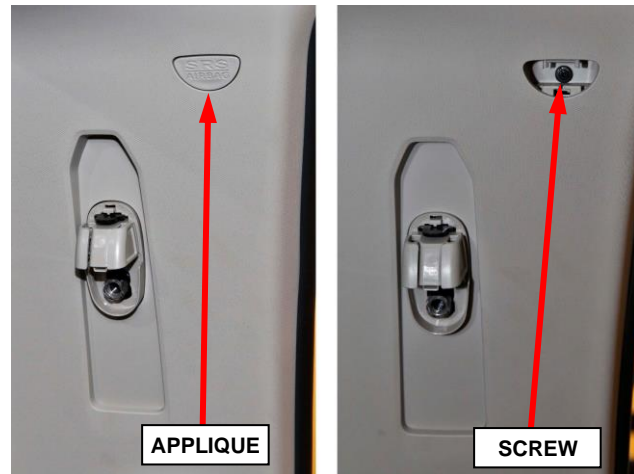
6. Separate the seatbelt turning loop cover then remove the turning loop bolt (Figure 4).



**Figure 4 – Seat Belt Turning Loop**

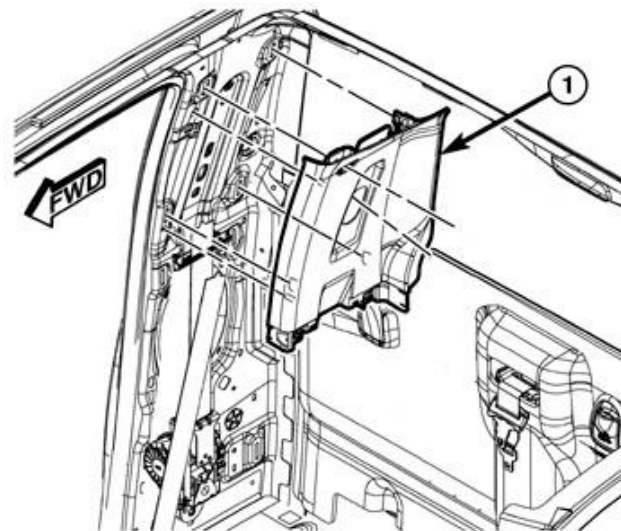
**Service Procedure [Continued]**

7. Using a trim stick or equivalent, release the B-pillar airbag applique then remove the screw that secures the upper trim panel (Figure 5).



**Figure 5 – B-Pillar Upper Trim Panel Fastener**

8. Release the retaining clips and remove the B-pillar upper trim panel (1) (Figure 6).



**Figure 6 – B-Pillar Upper Trim Panel**

9. Recline seat backs rearward to allow for room to lower the headliner.

**Service Procedure [Continued]**

10. Disconnect and isolate the negative battery cable. If equipped with an Intelligent Battery Sensor (IBS), disconnect the IBS connector first before disconnecting the negative battery cable. Wait two minutes for the system capacitor to discharge before further service.

**WARNING:** To avoid serious or fatal injury on vehicles equipped with airbags, disable the Supplemental Restraint System (SRS) before attempting any steering wheel, steering column, airbag, seat belt tensioner, impact sensor or instrument panel component diagnosis or service. Disconnect and isolate the battery negative (ground) cable, then wait two minutes for the system capacitor to discharge before performing further diagnosis or service. This is the only sure way to disable the SRS. Failure to take the proper precautions could result in accidental airbag deployment.

**WARNING:** To avoid serious or fatal injury when removing a deployed airbag, rubber gloves, eye protection, and a long-sleeved shirt should be worn. There may be deposits on the airbag unit and other interior surfaces. In large doses, these deposits may cause irritation to the skin and eyes.

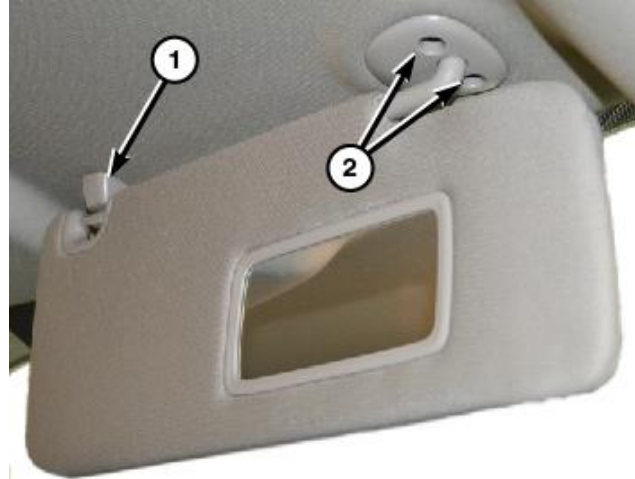
**WARNING:** To avoid serious or fatal injury, use extreme care to prevent any foreign material from entering the side curtain airbag, or becoming entrapped between the side curtain airbag cushion and the headliner. Failure to observe this warning could result in occupant injuries upon airbag deployment.

**NOTE:** The following procedure is for replacement of an ineffective or damaged side curtain airbag (also known as Side Air Bag Inflatable Curtain/SABIC). If the airbag is ineffective or damaged, but not deployed, review local ordinances regarding recommended procedures for handling and disposal of Non-Deployed Supplemental Restraints.

**NOTE:** If a side curtain airbag is being removed, but has not been deployed, the headliner does not need to be removed from the passenger compartment. Lowering the headliner and resting it on the seat backs will allow enough clearance to remove the side curtain airbag from the vehicle.

**Service Procedure [Continued]**

**CAUTION: Hands should be clean or clean cloth gloves used when handling the visors and headliner to avoid marks or damage.**

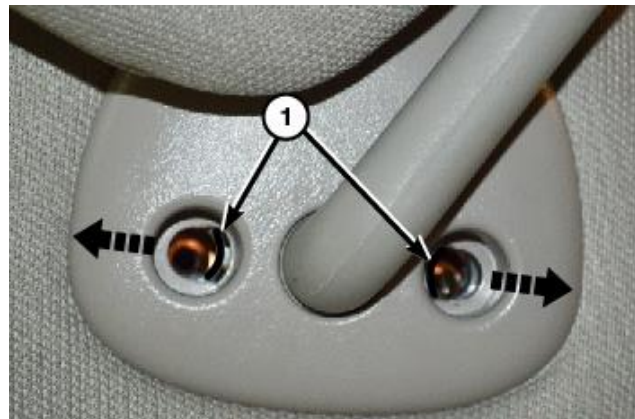


**Figure 7 – Visors**

11. Separate the visor from the support (1) then remove the screw and remove the visor support (Figure 7).

12. Remove the visor screws (2) then remove the visor (Figure 7).

Using a small flat bladed tool or equivalent, release the retaining tabs (1) and separate the visor from the headliner (Figure 8).

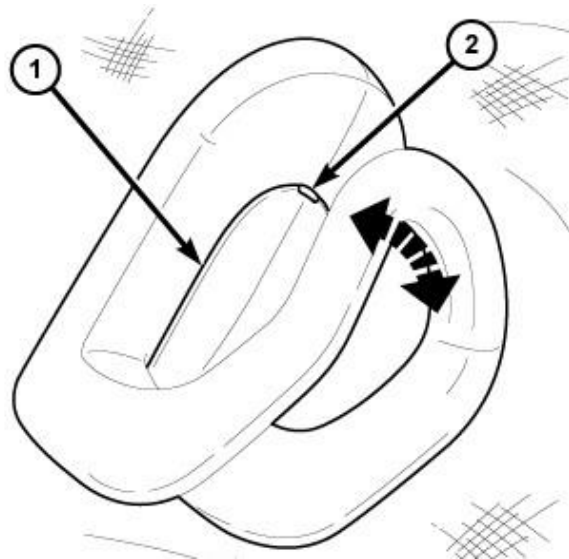


**Figure 8 – Visors**

13. Disconnect the visor electrical connector if equipped.

**NOTE: In some cases, the wire harness for the visor vanity mirror may be glued to the top side of the headliner and may be a little difficult to release.**

14. Using a small flat bladed tool, open the coat hook screw cover (2) then remove the screw and coat hook (Figure 9).

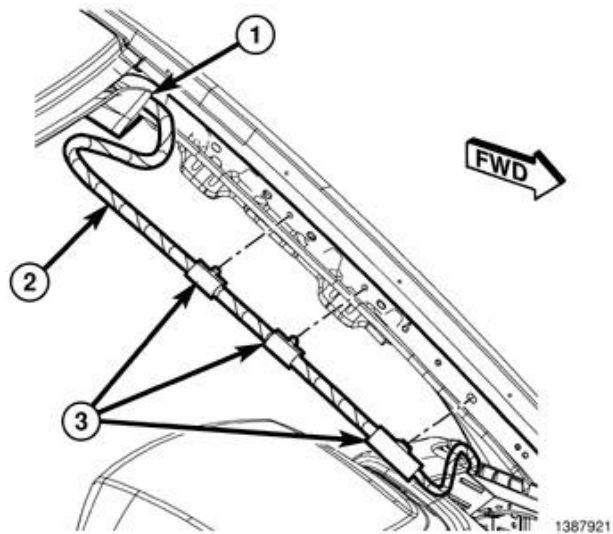


**Figure 9 – Coat Hook**



**Service Procedure [Continued]**

15. As necessary, release the headliner wiring harness clips (3) from the A-pillar to allow enough wiring harness slack for lowering the headliner (Figure 10).



**Figure 10 – Headliner Harness**

16. Release the door seals from the door openings to allow for lowering of the headliner.

17. Carefully lower the headliner allowing it to rest on the seat backs and instrument panel (Figure 11).

**CAUTION:** Disconnect any wiring harness electrical connectors as necessary to allow enough wiring harness slack for lowering headliner. It will not be necessary to remove the headliner from the vehicle.

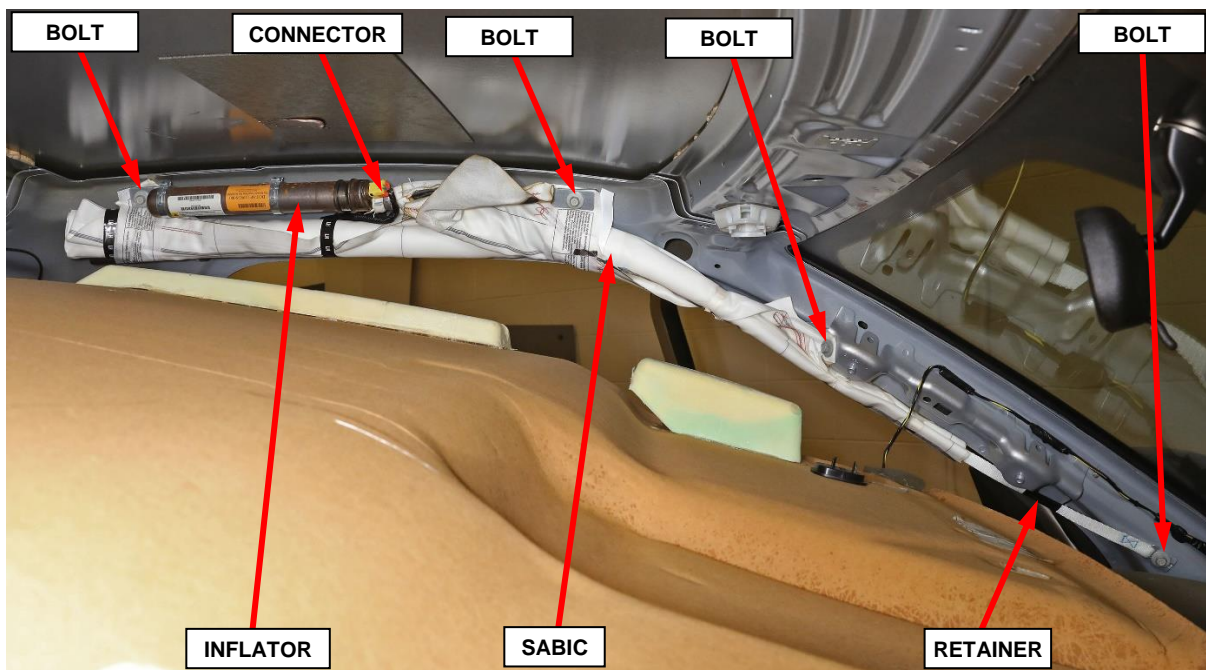


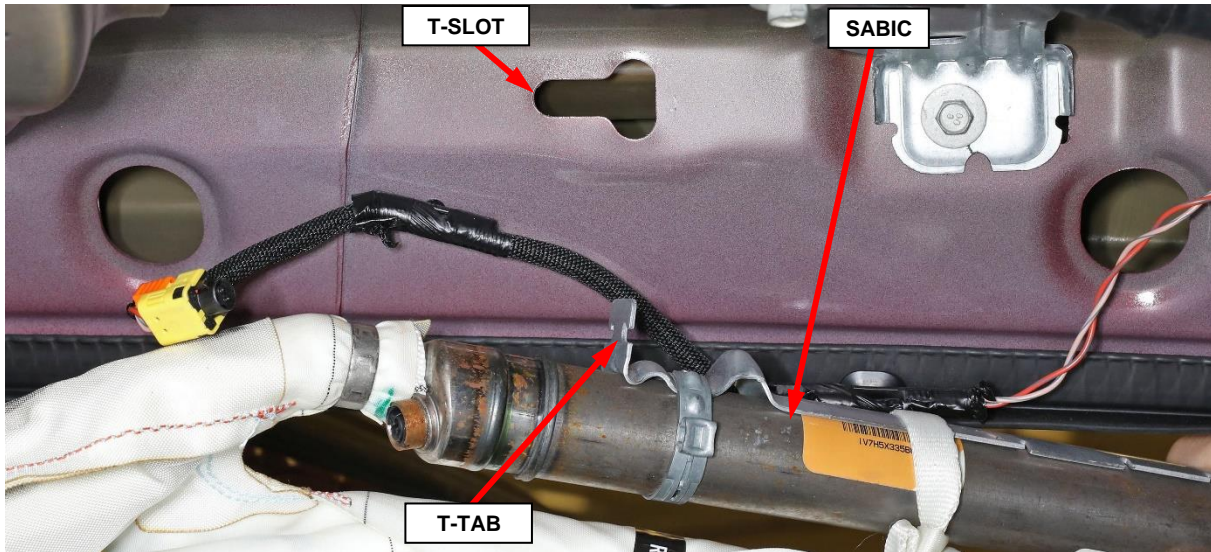
**Figure 11 – Headliner**

18. Obtain the appropriate replacement SABIC(s) for the vehicle based on its VIN.

**Service Procedure [Continued]**

19. The body wire harness connector is secured by integral latches to the connector receptacle on the inflator. Pinch both latches firmly, then pull the connector straight out from the airbag inflator to disconnect it from the connector receptacle (Figure 12).
20. Remove the four bolts that secure the side curtain airbag to the inner roof rail and A-pillar (Figure 12).
21. Disengage the one plastic push-in retainer that secures the side curtain airbag tether to the inner A-pillar (Figure 12).
22. Slide the inflator rearward far enough to disengage the T-tab at the front of the inflator bracket from the keyed T-slot in the inner roof rail over the front door opening (Figure 13).
23. Remove the SABIC from the vehicle as a unit and **DISCARD** following local ordinances and recommended procedures for handling and disposal of non-deployed supplemental restraints. Provided packaging is not authorized for the transport of the recalled SABIC Module. Parts will need to be either deployed on-site or transported in alternative approved containers.

**Figure 12 – SABIC**

**Service Procedure [Continued]**

**Figure 13 – SABIC Inflator T-Tab and Inner Roof Rail T-Slot**

24. Check to be certain that the two spring nuts are properly installed in the inner roof rail and that they are in good condition.
25. Position the **NEW SABIC** into the vehicle as a unit (Figure 12).
26. Insert the T-tab at the front of the inflator bracket into the keyed T-slot in the inner roof rail over the front door opening and slide the inflator forward to engage it (Figure 13).
27. Ensure the tether is not twisted then engage the one plastic push-in retainer that secures the side curtain airbag front tether to the assist handle bracket on the inner A-pillar (Figure 12).
28. Working from rear to front, install and tighten the four bolts that secure the side curtain airbag to the inner roof rail and A-pillar. Tighten the bolts to 7 N·m (62 in. lbs.) (Figure 12).
29. Connect the body wire harness connector for the side curtain airbag to the connector receptacle of the inflator. Be certain that each connector is fully engaged in its receptacle by listening carefully for a distinct, audible click as the connector latches snap into place (Figure 12).

**Service Procedure [Continued]**

**CAUTION: Hands should be clean or clean cloth gloves used when handling the headliner to avoid damage to the headliner.**

30. Raise the headliner into proper vehicle position and connect any electrical connectors previously disconnected from the headliner.

**CAUTION: Be certain to avoid any wiring or drain tube interference.**

31. Position the coat hooks (5) onto the headliner and install the screws tightening securely into the mounting clips then close the screw cap fully (Figure 9).
32. Position the visor supports (1) onto the headliner and install the screws into the mounting clips (Figure 7).
33. If equipped with illuminated vanity mirror, connect the wire harness connector.
34. Position the visor to the headliner and install the screws (2) that secure the visor to the roof panel. Tighten the screws to 6 N·m (53 in. lbs.) (Figure 7).
35. Reattach any headliner wiring harness clips (3) removed from the A-pillar to allow slack while lowering headliner (Figure 10).

**WARNING: Do not connect the negative battery cable at this time. The Supplemental Restraint System (SRS) Verification Test procedure should be performed following service of any SRS component.**

**NOTE: The following procedure should be performed using a diagnostic scan tool to verify proper Supplemental Restraint System (SRS) operation following the service or replacement of any SRS component. Refer to the appropriate diagnostic procedures.**

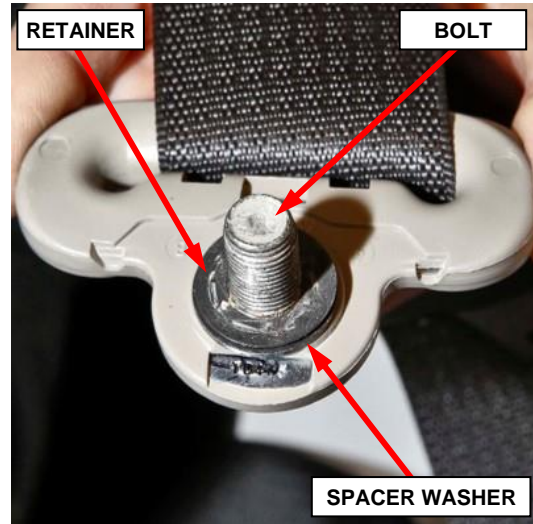
36. During the following test, the negative cable remains disconnected and isolated from the battery, as it was during the Supplemental Restraint System (SRS) component removal and installation procedures.

**Service Procedure [Continued]**

37. Be certain that the diagnostic scan tool contains the latest version of the proper diagnostic software. Connect the scan tool to the 16-way Data Link Connector (DLC). The DLC is located on the driver side lower edge of the instrument panel, near the steering column opening cover and outboard of the steering column.
38. Transition the status of the ignition switch (also known as the Keyless Ignition Node/KIN or IGnition Node Module/IGNM) to ON and exit the vehicle with the scan tool.
39. Check to be certain that nobody is in the vehicle, then connect the negative cable to the battery.
40. Using the scan tool, read and record the active (current) Diagnostic Trouble Code (DTC) data.
41. Next, use the scan tool to read and record any stored (historical) DTC data.
42. If any SRS related DTC is found in the previous two steps, refer to the appropriate diagnostic information.
43. Use the scan tool to erase the stored DTC data. If any problems remain, the stored DTC data will not erase. Refer to the appropriate diagnostic information to diagnose any stored DTC that will not erase. If the stored DTC information is successfully erased, continue to the next step.
44. Transition the status of the ignition switch to OFF for about 15 seconds, and then back to ON. Observe the airbag indicator in the instrument cluster. It should light from four to six seconds, and then go out. This indicates that the SRS is functioning normally and that the repairs are complete. If the airbag indicator fails to light, or lights and stays ON, there is still an active SRS fault or malfunction. Refer to the appropriate diagnostic information to diagnose the problem.
45. Raise the seat backs and position the seats forward.
46. Install the B-pillar upper trim panel (1) and engage the retaining clips fully (Figure 6).

**Service Procedure [Continued]**

47. Install and tighten the screw that secures the B-pillar upper trim panel then install the airbag applique cover (Figure 5).
48. Remove and **DISCARD** the bolt retainer and the bolt from the seat belt turning loop, save the spacer washer for reuse (Figure 14).
49. Using a **NEW** bolt and reusing the spacer washer, install the turning loop then tighten the bolt to 40 N·m (30 ft. lbs.) (Figure 4).
50. Install the turning loop cover (Figure 4).
51. Position the B-pillar lower trim panel and engage the retaining clips fully (Figure 3).

**Figure 14 – Headliner**

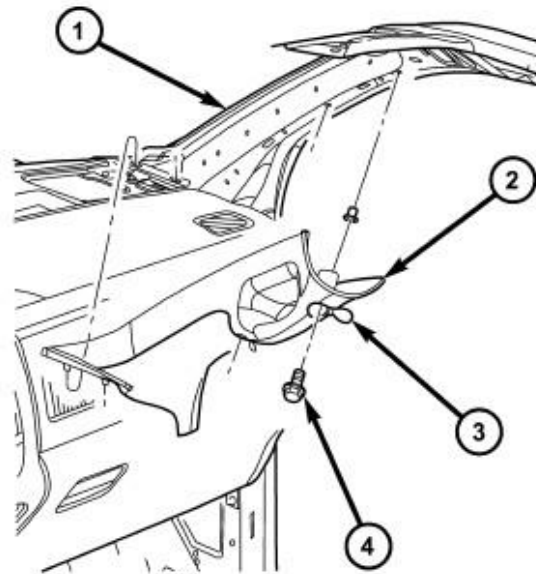
**NOTE: Ensure that all B-pillar fasteners are installed/engaged properly.**

52. Install the front seat headrests (Figure 2).
53. Position the locating tab of the A-pillar trim panel (2) into the slot located in the top of the instrument panel (Figure 1).
54. Install the A-pillar trim panel onto the A-pillar (1) and install the two bolts (4). Tighten the bolts to 5 N·m (44 in. lbs.) (Figure 1).
55. Close the two fastener covers (3) located in the A-pillar trim panel (Figure 1).
56. Install the door seals around the door openings.
57. Return the vehicle to the customer or inventory.

**Service Procedure [Continued]**

**B. Quad Cab**

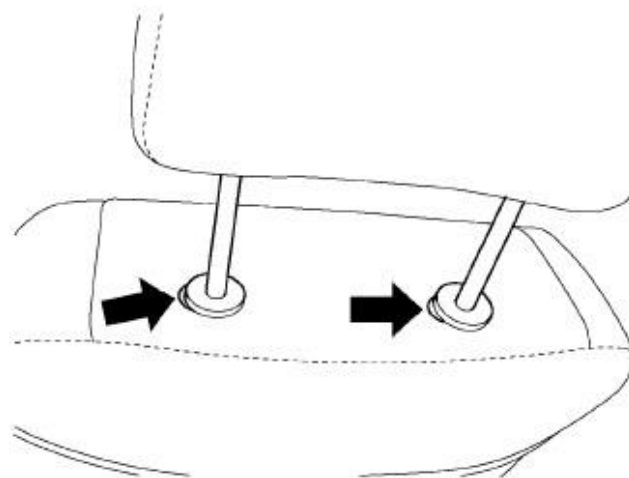
1. Using a small flat-bladed tool, carefully open the two fastener covers (3) located in the A-pillar trim panel (2) (Figure 15).
  
2. Remove the two bolts (4) that secure the A-pillar trim panel to the A-pillar (1) and remove the trim panel (Figure 15).



80d407a9

**Figure 15 – A-Pillar**

3. Push in the buttons on front seat headrest sleeves then pull the headrest up and remove (Figure 16).



8120dd43

**Figure 16 – Head Rest**

4. Position the front seats to the full forward position with the seat backs fully forward.

**Service Procedure [Continued]**

5. Disconnect and isolate the negative battery cable. If equipped with an Intelligent Battery Sensor (IBS), disconnect the IBS connector first before disconnecting the negative battery cable. Wait two minutes for the system capacitor to discharge before further service.

**WARNING:** To avoid serious or fatal injury on vehicles equipped with airbags, disable the Supplemental Restraint System (SRS) before attempting any steering wheel, steering column, airbag, seat belt tensioner, impact sensor or instrument panel component diagnosis or service. Disconnect and isolate the battery negative (ground) cable, then wait two minutes for the system capacitor to discharge before performing further diagnosis or service. This is the only sure way to disable the SRS. Failure to take the proper precautions could result in accidental airbag deployment.

**WARNING:** To avoid serious or fatal injury when removing a deployed airbag, rubber gloves, eye protection, and a long-sleeved shirt should be worn. There may be deposits on the airbag unit and other interior surfaces. In large doses, these deposits may cause irritation to the skin and eyes.

**WARNING:** To avoid serious or fatal injury, use extreme care to prevent any foreign material from entering the side curtain airbag, or becoming entrapped between the side curtain airbag cushion and the headliner. Failure to observe this warning could result in occupant injuries upon airbag deployment.

**NOTE:** The following procedure is for replacement of an ineffective or damaged side curtain airbag (also known as Side Air Bag Inflatable Curtain/SABIC). If the airbag is ineffective or damaged, but not deployed, review local ordinances regarding recommended procedures for handling and disposal of Non-Deployed Supplemental Restraints.

**NOTE:** If a side curtain airbag is being removed, but has not been deployed, the headliner does not need to be removed from the passenger compartment. Lowering the headliner and resting it on the seat backs will allow enough clearance to remove the side curtain airbag from the vehicle.



**Service Procedure [Continued]**

6. Release the front and rear door sill scuff plates on either side of the B-pillar lower trim panel to allow for removal of the B-pillar lower trim panel (Figure 17).



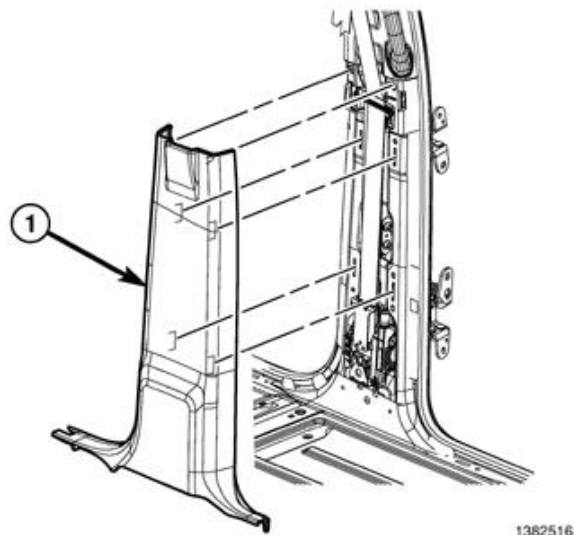
**Front Door Sill**



**Rear Door Sill**

**Figure 17 – Door Sill Scuff Plates**

7. Release the retaining clips and remove the B-pillar lower trim panel to allow for removal of the B-pillar upper trim panel (Figure 18).

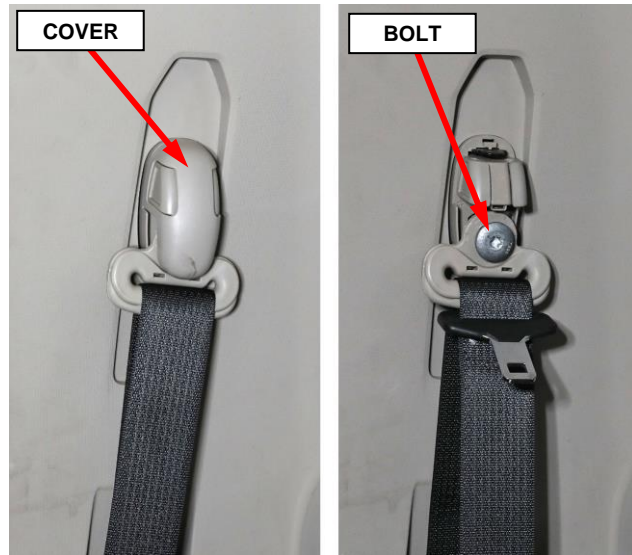


1382516

**Figure 18 – B-Pillar Lower Trim Panel**

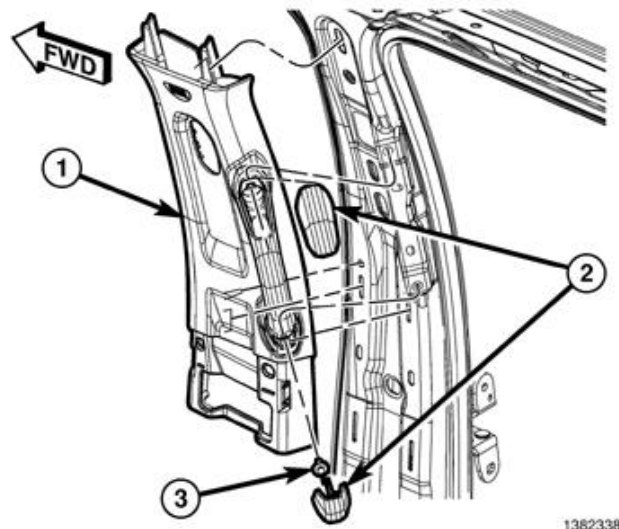
**Service Procedure [Continued]**

8. On the B-pillar, separate the seatbelt turning loop cover then remove the turning loop bolt (Figure 19).



**Figure 19 – Seat Belt Turning Loop**

9. On the B-pillar, use a small flat-bladed tool to carefully open the two fastener covers (2) located on the grab handle (Figure 20).

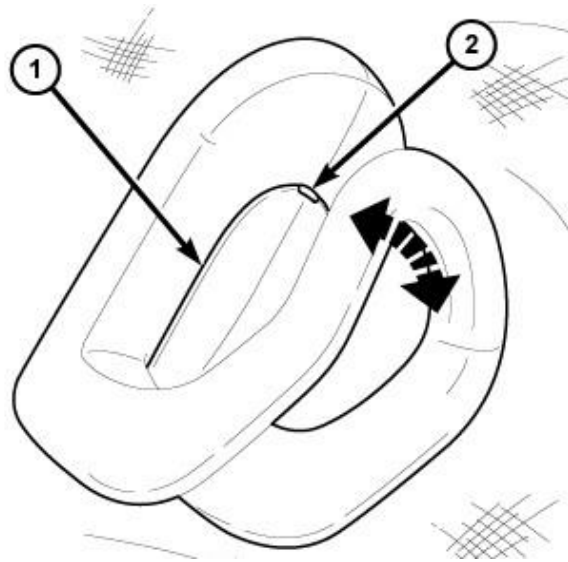


**Figure 20 – B-Pillar Upper Trim Panel**

11. Using a trim stick C-4755 or equivalent, release the retaining clips that secure the B-pillar upper trim panel (1) then position the trim panel out of the way. It is not necessary to remove the seat belt from the trim panel (Figure 20).

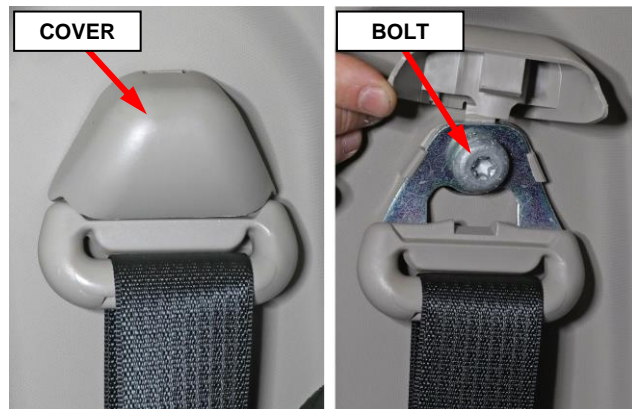
**Service Procedure [Continued]**

12. Using a small flat bladed tool, open the coat hook screw cover (2) then remove the screw and coat hook (Figure 21).



**Figure 21 – Coat Hook**

13. On the C-pillar, lift the seat belt turning loop cover then remove the turning loop bolt (Figure 22).

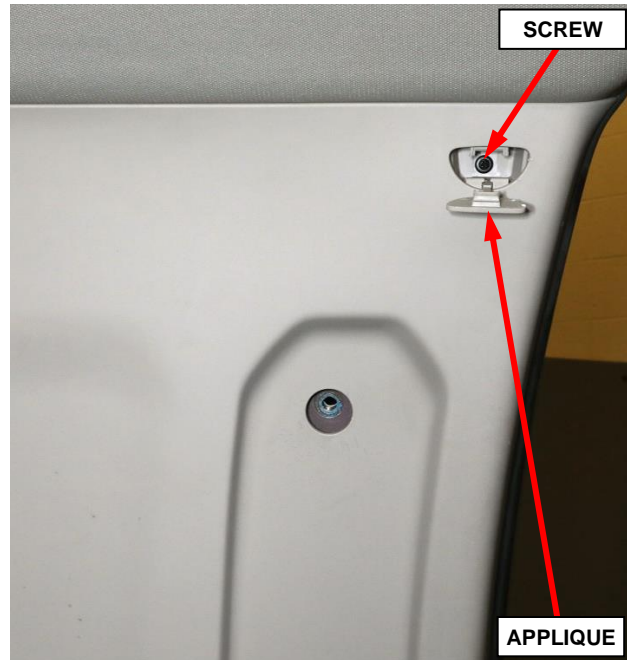


**Figure 22 – Seat Belt Turning Loop**

**Service Procedure [Continued]**

**NOTE: Do not drop the screw inside the C-pillar, a magnetic screw driver may be helpful.**

- Using a trim stick or equivalent, release the C-pillar airbag applique then remove the screw that secures the upper trim panel (Figure 23).



**Figure 23 – C-Pillar Upper Trim Panel**

- Release the retaining clips and tilt the top of the C-pillar upper trim panel inward (Figure 24).

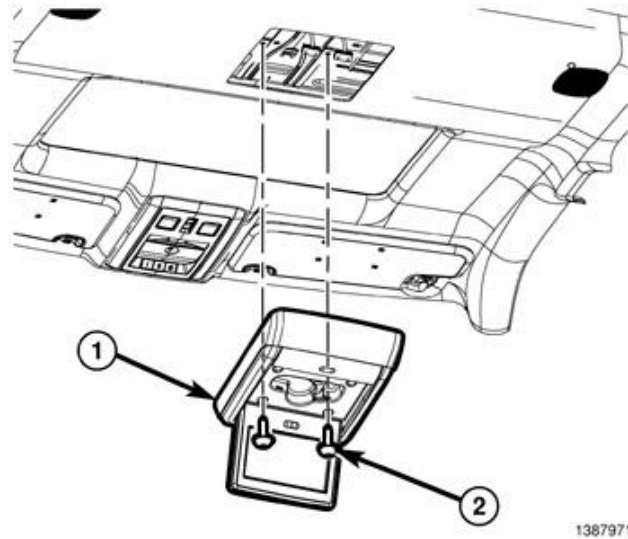


**Figure 24 – C-Pillar Upper Trim Panel**

**Service Procedure [Continued]**

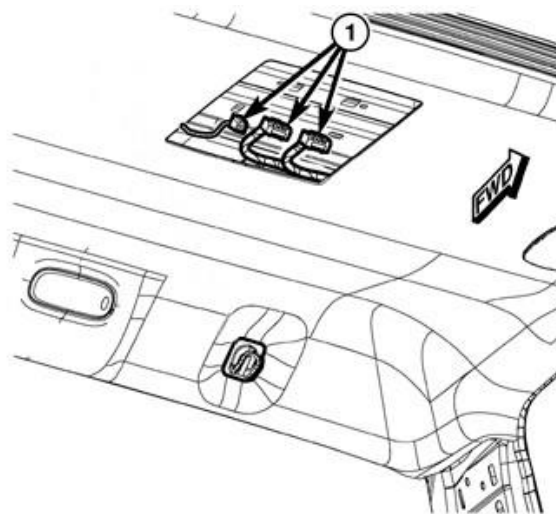
**CAUTION:** Hands should be clean or clean cloth gloves used when handling the visors and headliner to avoid marks or damage.

16. If equipped with DVD monitor, remove the screws (2) and separate the monitor (1) from the roof (Figure 25).



**Figure 25 – Rear Seat DVD Monitor**

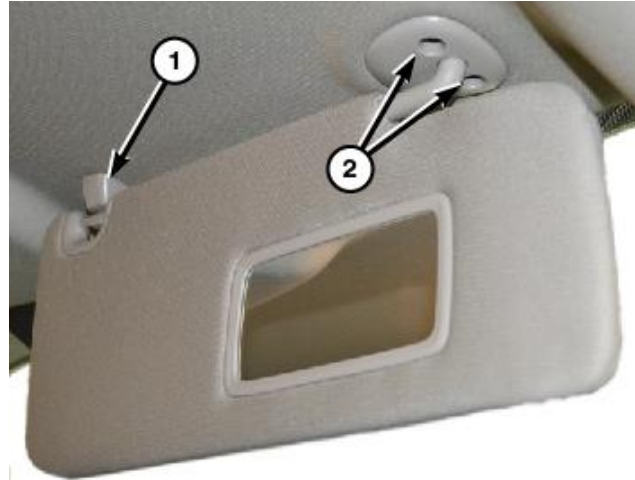
17. If equipped with DVD monitor, disconnect the electrical connectors (1) (Figure 26).



**Figure 26 – DVD Monitor Electrical Connectors**

**Service Procedure [Continued]**

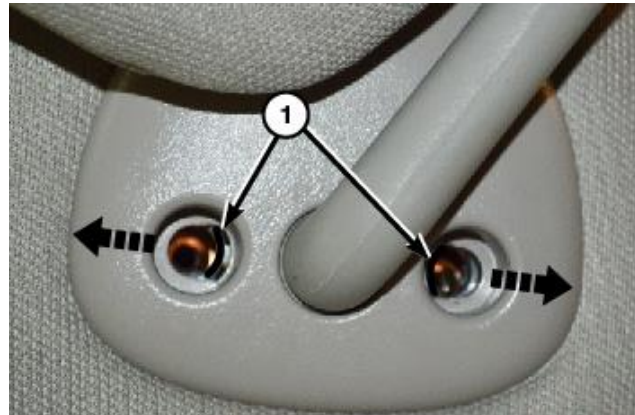
18. Separate the visor from the support (1) then remove the screw and remove the visor support (Figure 27).



**Figure 27 – Visors**

19. Remove the visor screws (2) then remove the visor (Figure 27).

Using a small flat bladed tool or equivalent, release the retaining tabs (1) and separate the visor from the headliner (Figure 28).

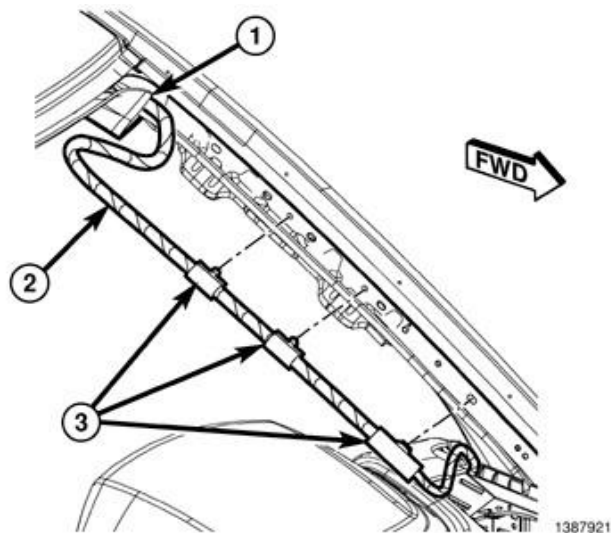


**Figure 28 – Visors**

20. Disconnect the visor electrical connector if equipped.

**NOTE: In some cases, the wire harness for the visor vanity mirror may be glued to the top side of the headliner and may be a little difficult to release.**

21. As necessary, release the headliner wiring harness clips (3) from the A-pillar to allow enough wiring harness slack for lowering the headliner (Figure 29).



**Figure 29 – Headliner Harness**

**Service Procedure [Continued]**

22. Release the door seals from the door openings to allow for lowering of the headliner.
23. Tilt the rear view mirror up to allow clearance for lowering the headliner (Figure 30).
24. Carefully tilt the front of the headliner (2) down to clear the rear view mirror then slide the headliner forward to clear the C-pillar trim while disconnecting any wiring harness electrical connectors (1) as necessary to allow enough wiring harness slack to lower the headliner (Figure 31).

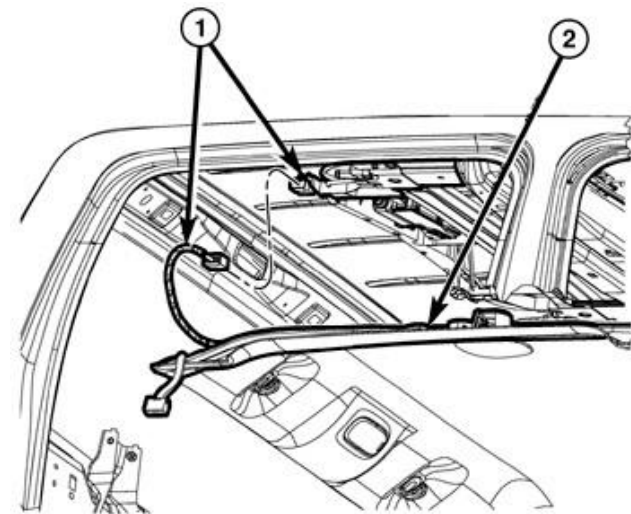


**Figure 30 – Headliner Harness**

25. lower the headliner (2) allowing it to rest on the seat backs and instrument panel (Figure 31).

**NOTE: It will not be necessary to remove the headliner from the vehicle.**

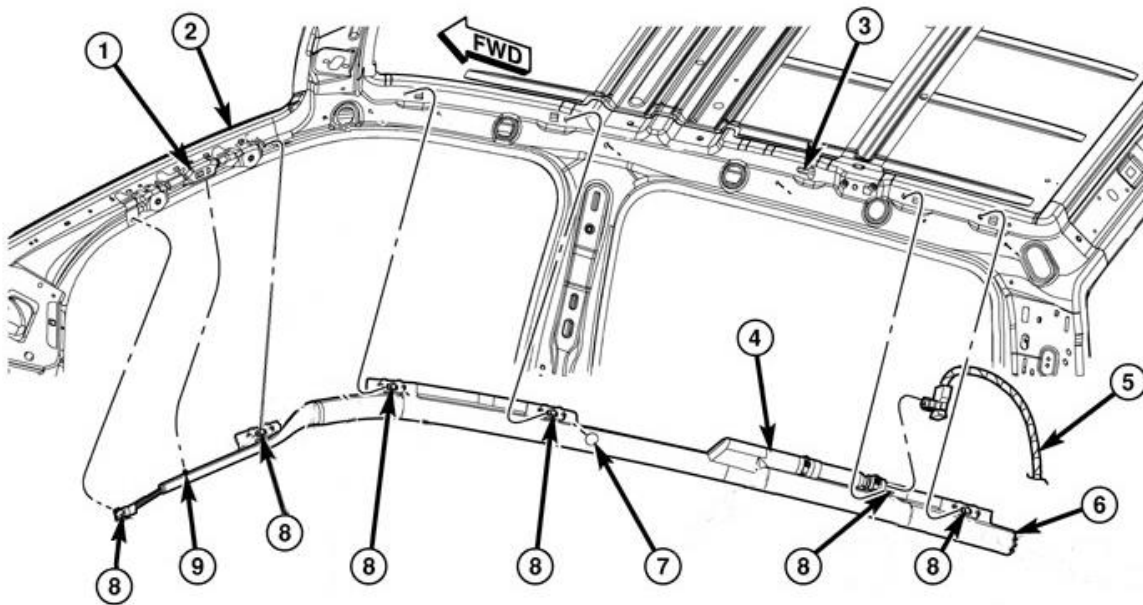
26. Obtain the appropriate replacement SABIC(s) for the vehicle based on its VIN.



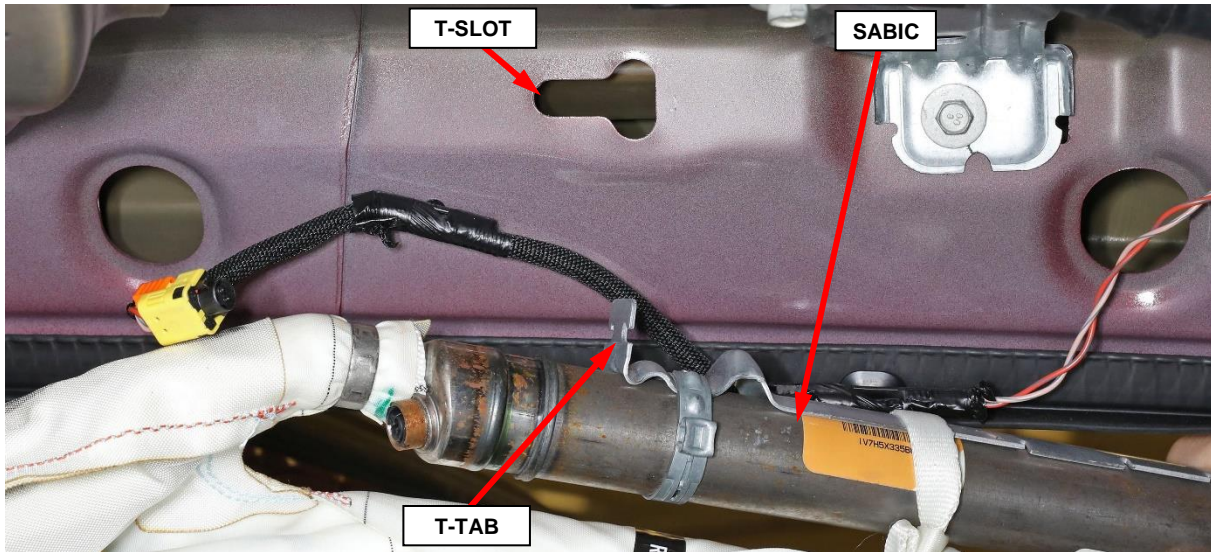
**Figure 31 – Headliner Harness**

**Service Procedure [Continued]**

27. The body wire harness connector (5) is secured by integral latches to the connector receptacle on the inflator (4). Pinch both latches firmly, then pull the connector straight out from the airbag inflator to disconnect it from the connector receptacle (Figure 32).
28. Remove the six bolts (8) that secure the side curtain airbag (6) to the inner roof rail and A-pillar (Figure 32).
29. Disengage the plastic push-in retainer (9) that secures the side curtain airbag tether to the inner A-pillar (1) and the plastic push-in retainer (7) that secures the side curtain airbag to the inner roof rail (Figure 32).
30. Slide the inflator rearward far enough to disengage the T-tab at the front of the inflator bracket from the keyed T-slot in the inner roof rail over the rear door opening (Figure 33).
31. Remove the SABIC (6) from the vehicle as a unit and **DISCARD** following local ordinances and recommended procedures for handling and disposal of Non-Deployed Supplemental Restraints (Figure 32). Provided packaging is not authorized for the transport of the recalled SABIC Module. Parts will need to be either deployed on-site or transported in alternative approved containers.

**Figure 32 – SABIC**



**Service Procedure [Continued]**

**Figure 33 – SABIC Inflator T-Tab and Inner Roof Rail T-Slot**

32. Check to be certain that the spring nuts are properly installed in the inner roof rail and that they are in good condition.
33. Position the **NEW SABIC** (6) into the vehicle as a unit (Figure 32).
34. Insert the T-tab at the front of the inflator bracket into the keyed T-slot in the inner roof rail over the rear door opening and slide the inflator forward to engage it (Figure 33).
35. Engage the plastic push-in retainer (7) that secures the side curtain airbag to the inner roof rail and ensure the tether is not twisted then engage the plastic push-in retainer (9) that secures the side curtain airbag front tether to the assist handle bracket on the inner A-pillar (1) (Figure 32).
36. Working from rear to front, install and tighten the seven bolts (8) that secure the side curtain airbag (6) to the inner roof rail and A-pillar. Tighten the bolts to 7 N·m (62 in. lbs.) (Figure 32).
37. Connect the body wire harness connector (5) for the side curtain airbag to the connector receptacle of the inflator (4). Be certain that each connector is fully engaged in its receptacle by listening carefully for a distinct, audible click as the connector latches snap into place (Figure 32).

**Service Procedure [Continued]**

**CAUTION: Hands should be clean or clean cloth gloves used when handling the headliner to avoid damage to the headliner.**

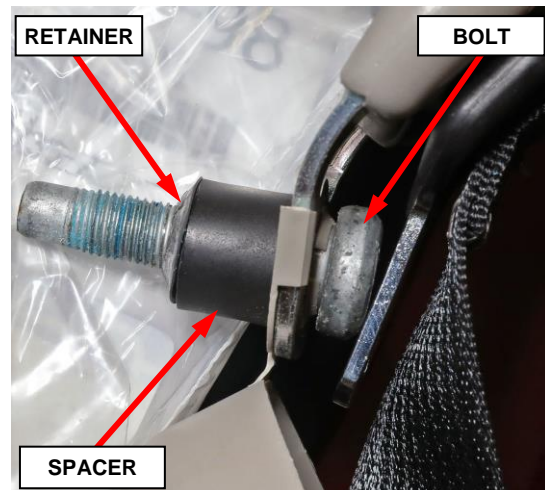
38. Raise the headliner into proper vehicle position and connect any electrical connectors previously disconnected from the headliner (Figure 31).

**CAUTION: Be certain to avoid any wiring or drain tube interference.**

39. Tilt the rear view mirror down to support the headliner (Figure 30).
40. Reattach any headliner wiring harness clips (3) removed from the A-pillar to allow slack while lowering headliner (Figure 29).
41. Position the visor supports (1) onto the headliner and install the screws into the mounting clips (Figure 27).
42. If equipped with illuminated vanity mirror, connect the wire harness connector.
43. Position the visor to the headliner and install the screws (2) that secure the visor to the roof panel. Tighten the screws to 6 N·m (53 in. lbs.) (Figure 27).
44. If equipped with DVD monitor, connect the DVD monitor electrical connectors (1) (Figure 26). Position the DVD monitor to the roof then install and tighten the screws (2) (Figure 25).

**Service Procedure [Continued]**

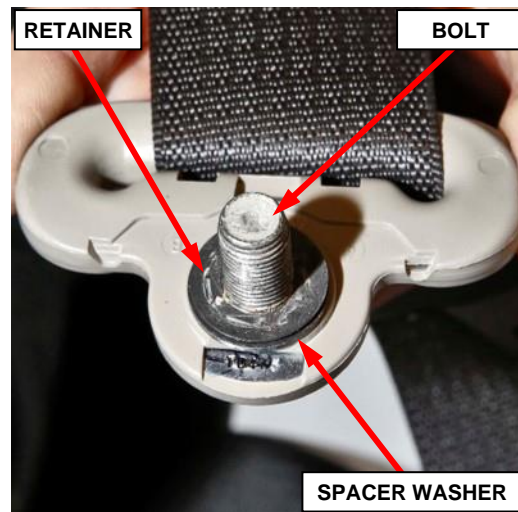
45. Position the upper trim to the C-pillar then engage the retaining clips (Figure 24).
46. Install and tighten the screw that secures the C-pillar upper trim panel. Then install the airbag applique (Figure 23).
47. Remove and **DISCARD** the bolt retainer and bolt from the seat belt turning loop, save the spacer washer for reuse (Figure 34).
48. Using a **NEW** bolt and reusing the spacer, install the turning loop then tighten the bolt to 40 N·m (30 ft. lbs.) (Figure 22).

**Figure 34 – Turning Loop Bolt**

49. Install the seat belt turning loop cover (Figure 22).
50. Position the coat hooks (5) onto the headliner and install the screws tightening securely into the mounting clips then close the screw cap fully (Figure 21).

**Service Procedure [Continued]**

51. Install the B-pillar upper trim panel (1) and engage the retaining clips fully (Figure 20).
52. Install the grab handle bolts (3) and tighten to 5 N·m (44 in. lbs.). Close the fastener covers (2) (Figure 20).
53. Remove and **DISCARD** the bolt retainer and bolt from the seat belt turning loop, save the spacer washer for reuse (Figure 35).
54. Using a **NEW** bolt and reusing the spacer washer, install the turning loop then tighten the bolt to 40 N·m (30 ft. lbs.) (Figure 19).
55. Install the seat belt turning loop cover (Figure 19).
56. Position the B-pillar lower trim panel and engage the retaining clips fully (Figure 18).
57. Position the front and rear door sill scuff plates and engage the retainers (Figure 17).

**Figure 35 – Turning Loop Bolt**

**Service Procedure [Continued]**

**WARNING: Do not connect the negative battery cable at this time. The Supplemental Restraint System (SRS) Verification Test procedure should be performed following service of any SRS component.**

**NOTE: The following procedure should be performed using a diagnostic scan tool to verify proper Supplemental Restraint System (SRS) operation following the service or replacement of any SRS component. Refer to the appropriate diagnostic procedures.**

58. During the following test, the negative cable remains disconnected and isolated from the battery, as it was during the Supplemental Restraint System (SRS) component removal and installation procedures.
59. Be certain that the diagnostic scan tool contains the latest version of the proper diagnostic software. Connect the scan tool to the 16-way Data Link Connector (DLC). The DLC is located on the driver side lower edge of the instrument panel, near the steering column opening cover and outboard of the steering column.
60. Transition the status of the ignition switch (also known as the Keyless Ignition Node/KIN or Ignition Node Module/IGNM) to ON and exit the vehicle with the scan tool.
61. Check to be certain that nobody is in the vehicle, then connect the negative cable to the battery.

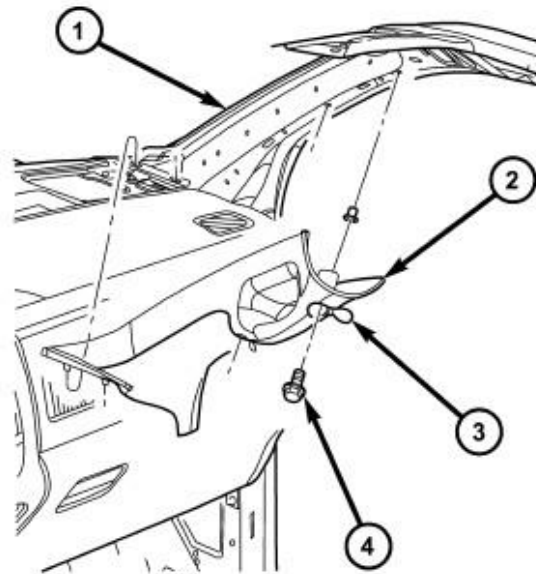
**Service Procedure [Continued]**

62. Using the scan tool, read and record the active (current) Diagnostic Trouble Code (DTC) data.
63. Next, use the scan tool to read and record any stored (historical) DTC data.
64. If any SRS related DTC is found in the previous two steps, refer to the appropriate diagnostic information.
65. Use the scan tool to erase the stored DTC data. If any problems remain, the stored DTC data will not erase. Refer to the appropriate diagnostic information to diagnose any stored DTC that will not erase. If the stored DTC information is successfully erased, continue to the next step.
66. Transition the status of the ignition switch to OFF for about 15 seconds, and then back to ON. Observe the airbag indicator in the instrument cluster. It should light from four to six seconds, and then go out. This indicates that the SRS is functioning normally and that the repairs are complete. If the airbag indicator fails to light, or lights and stays ON, there is still an active SRS fault or malfunction. Refer to the appropriate diagnostic information to diagnose the problem.
67. Install the front seat headrests (Figure 16).
68. Position the locating tab of the A-pillar trim panel (2) into the slot located in the top of the instrument panel (Figure 15).
69. Install the A-pillar trim panel onto the A-pillar (1) and install the two bolts (4). Tighten the bolts to 5 N·m (44 in. lbs.) (Figure 15).
70. Close the two fastener covers (3) located in the A-pillar trim panel (Figure 15).
71. Install the door seals around the door openings.
72. Return the vehicle to the customer or inventory.

**Service Procedure [Continued]**

**C. Crew Cab**

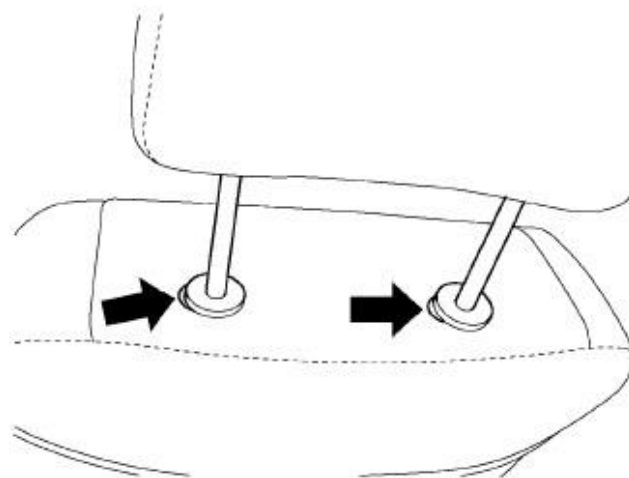
1. Using a small flat-bladed tool, carefully open the two fastener covers (3) located in the A-pillar trim panel (2) (Figure 36).
  
2. Remove the two bolts (4) that secure the A-pillar trim panel to the A-pillar (1) and remove the trim panel (Figure 36).



80d407a9

**Figure 36 – A-Pillar**

3. Push in the buttons on front seat headrest sleeves then pull the headrest up and remove (Figure 37).



8120dd43

4. Position the front seats to the full forward position with the seat backs fully forward.

**Figure 37 – Head Rest**

**Service Procedure [Continued]**

5. Disconnect and isolate the negative battery cable. If equipped with an Intelligent Battery Sensor (IBS), disconnect the IBS connector first before disconnecting the negative battery cable. Wait two minutes for the system capacitor to discharge before further service.

**WARNING:** To avoid serious or fatal injury on vehicles equipped with airbags, disable the Supplemental Restraint System (SRS) before attempting any steering wheel, steering column, airbag, seat belt tensioner, impact sensor or instrument panel component diagnosis or service. Disconnect and isolate the battery negative (ground) cable, then wait two minutes for the system capacitor to discharge before performing further diagnosis or service. This is the only sure way to disable the SRS. Failure to take the proper precautions could result in accidental airbag deployment.

**WARNING:** To avoid serious or fatal injury when removing a deployed airbag, rubber gloves, eye protection, and a long-sleeved shirt should be worn. There may be deposits on the airbag unit and other interior surfaces. In large doses, these deposits may cause irritation to the skin and eyes.

**WARNING:** To avoid serious or fatal injury, use extreme care to prevent any foreign material from entering the side curtain airbag, or becoming entrapped between the side curtain airbag cushion and the headliner. Failure to observe this warning could result in occupant injuries upon airbag deployment.

**NOTE:** The following procedure is for replacement of an ineffective or damaged side curtain airbag (also known as Side Air Bag Inflatable Curtain/SABIC). If the airbag is ineffective or damaged, but not deployed, review local ordinances regarding recommended procedures for handling and disposal of Non-Deployed Supplemental Restraints.

**NOTE:** If a side curtain airbag is being removed, but has not been deployed, the headliner does not need to be removed from the passenger compartment. Lowering the headliner and resting it on the seat backs will allow enough clearance to remove the side curtain airbag from the vehicle.



**Service Procedure [Continued]**

6. Release the front and rear door sill scuff plates on either side of the B-pillar lower trim panel to allow for removal of the B-pillar lower trim panel (Figure 38).



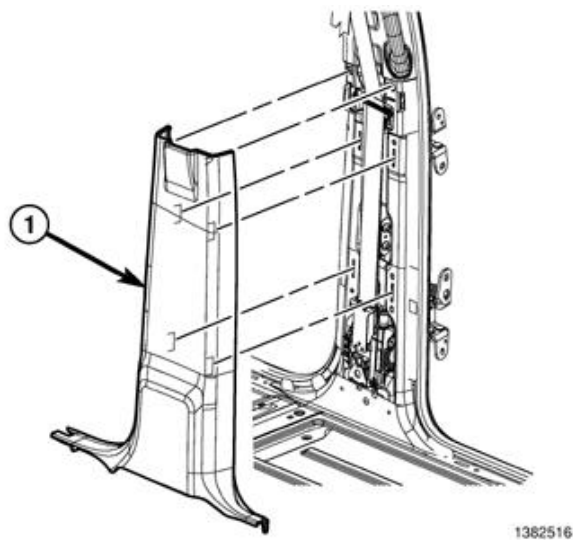
**Front Door Sill**



**Rear Door Sill**

**Figure 38 – Door Sill Scuff Plates**

7. Release the retaining clips and remove the B-pillar lower trim panel to allow for removal of the B-pillar upper trim panel (Figure 39).

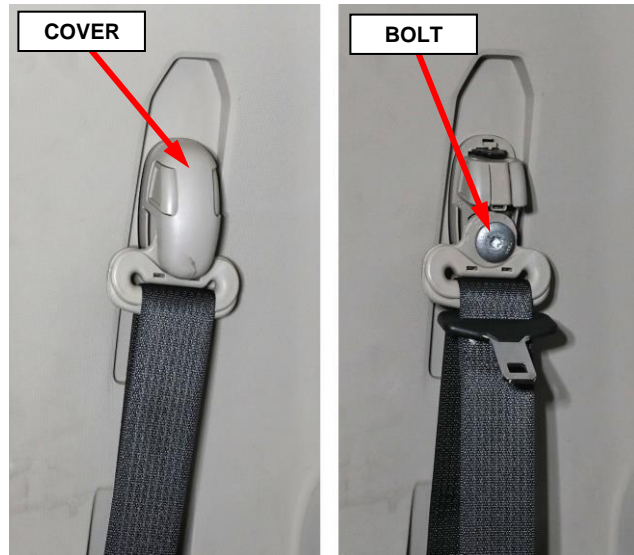


1382516

**Figure 39 – B-Pillar Lower Trim Panel**

**Service Procedure [Continued]**

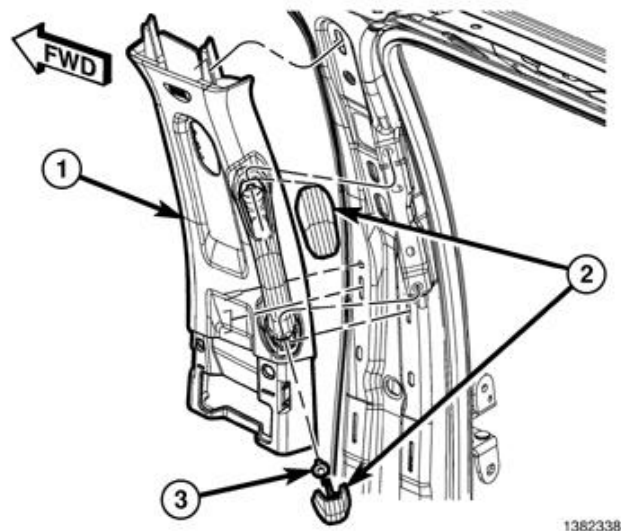
8. On the B-pillar, separate the seatbelt turning loop cover then remove the turning loop bolt (Figure 40).



**Figure 40 – Seat Belt Turning Loop**

9. On the B-pillar, use a small flat-bladed tool to carefully open the two fastener covers (2) located on the grab handle (Figure 41).

10. Remove the two bolts (3) that secure the grab handle to the B-pillar (Figure 41).

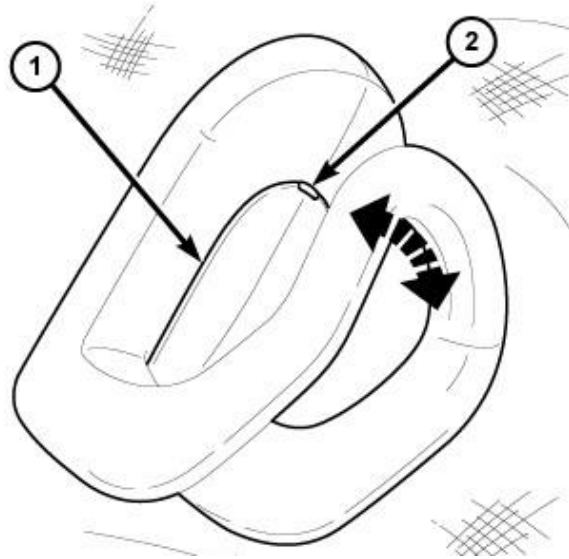


**Figure 41 – B-Pillar Upper Trim Panel**

11. Using a trim stick C-4755 or equivalent, release the retaining clips that secure the B-pillar upper trim panel (1) then position the trim panel out of the way. It is not necessary to remove the seat belt from the trim panel (Figure 41).

**Service Procedure [Continued]**

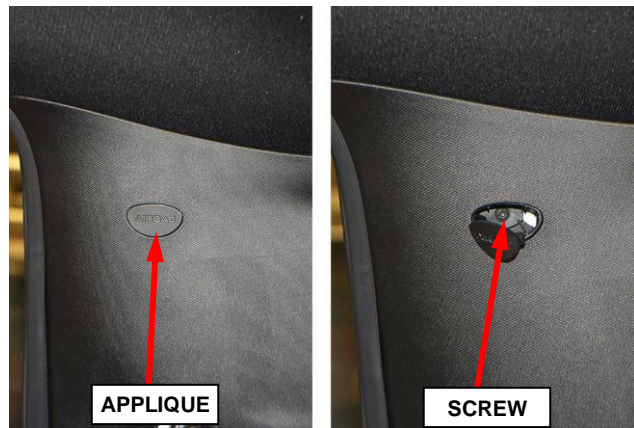
- Using a small flat bladed tool, open the coat hook screw cover (2) then remove the screw and coat hook (Figure 42).



**Figure 42 – Coat Hook**

**NOTE: Do not drop the screw inside the C-pillar, a magnetic screw driver may be helpful.**

- Using a trim stick or equivalent, release the C-pillar airbag applique then remove the screw that secures the upper trim panel (Figure 43).



**Figure 43 – C-Pillar Upper Trim Panel**

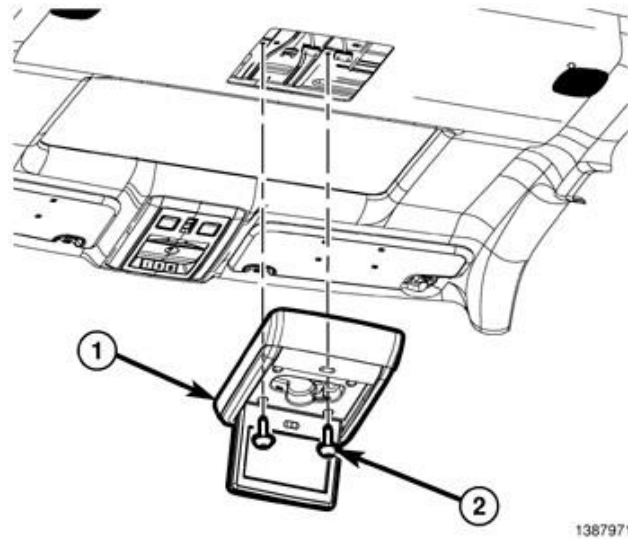
- Release the retaining clips and tilt the top of the C-pillar upper trim panel inward (Figure 44).



**Figure 44 – C-Pillar Trim Panels**

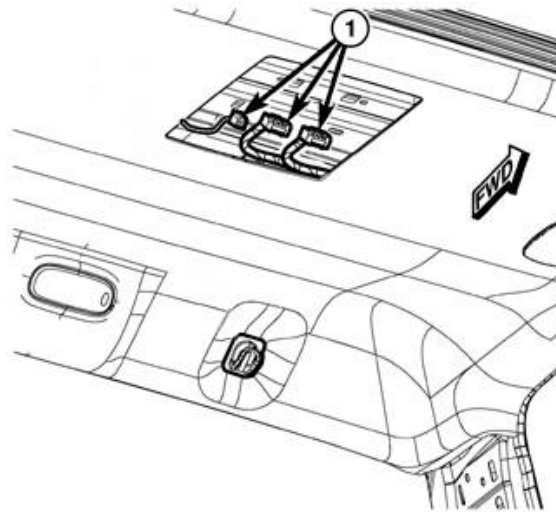
**Service Procedure [Continued]**

15. If equipped with DVD monitor, remove the screws (2) and separate the monitor (1) from the roof (Figure 45).



**Figure 45 – Rear Seat DVD Monitor**

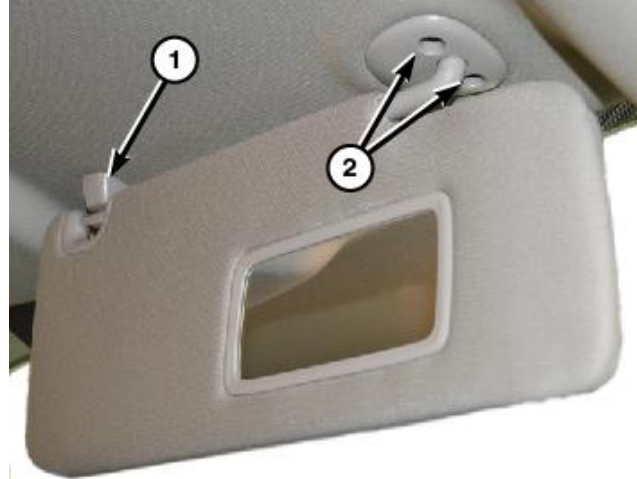
16. If equipped with DVD monitor, disconnect the electrical connectors (1) (Figure 46).



**Figure 46 – DVD Monitor Electrical Connectors**

**Service Procedure [Continued]**

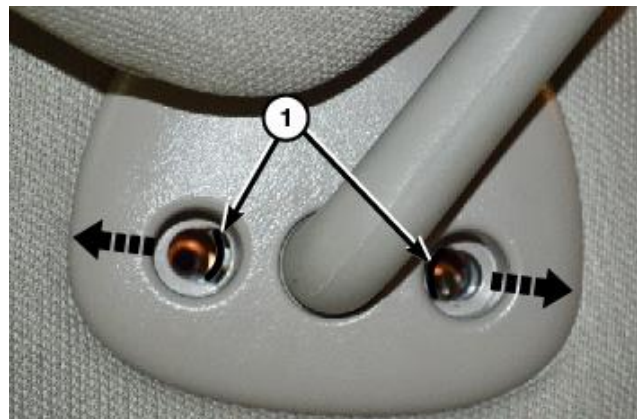
17. Separate the visor from the support (1) then remove the screw and remove the visor support (Figure 47).



**Figure 47 – Visors**

18. Remove the visor screws (2) then remove the visor (Figure 47).

Using a small flat bladed tool or equivalent, release the retaining tabs (1) and separate the visor from the headliner (Figure 48).

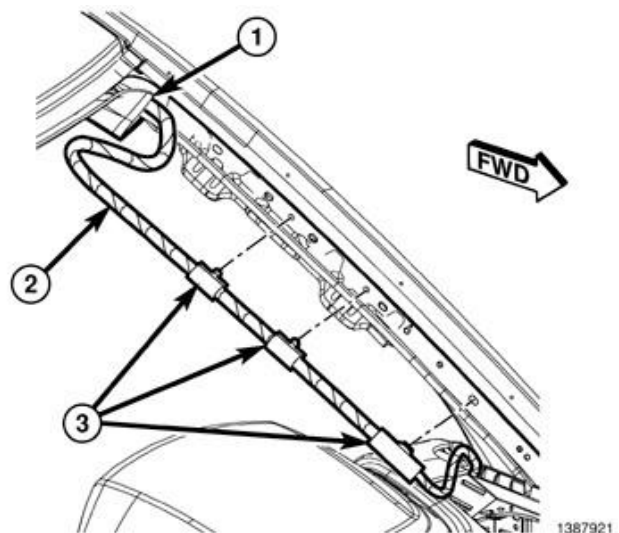


**Figure 48 – Visors**

19. Disconnect the visor electrical connector if equipped.

**NOTE: In some cases, the wire harness for the visor vanity mirror may be glued to the top side of the headliner and may be a little difficult to release.**

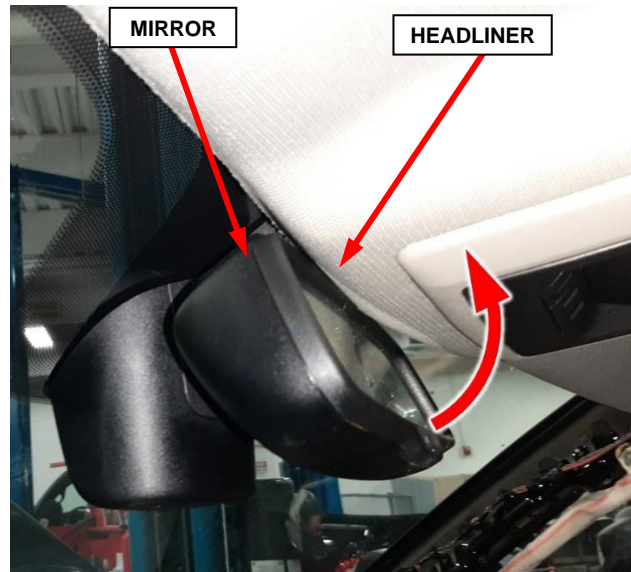
20. As necessary, release the headliner wiring harness clips (3) from the A-pillar to allow enough wiring harness slack for lowering the headliner (Figure 49).



**Figure 49 – Headliner Harness**

**Service Procedure [Continued]**

- 21. Release the door seals from the door openings to allow for lowering of the headliner.
- 22. Tilt the rear view mirror up to allow clearance for lowering the headliner (Figure 50).
- 23. Carefully tilt the front of the headliner (2) down to clear the rear view mirror then slide the headliner forward to clear the C-pillar trim while disconnecting any wiring harness electrical connectors (1) as necessary to allow enough wiring harness slack to lower the headliner (Figure 51).

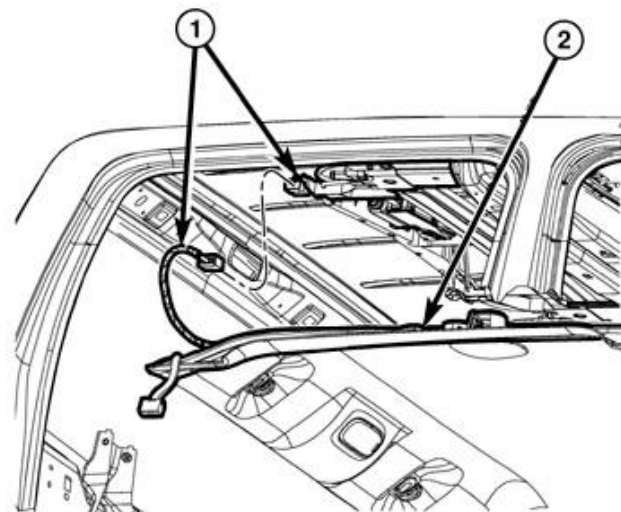


**Figure 50 – Rearview Mirror**

- 24. lower the headliner (2) allowing it to rest on the seat backs and instrument panel (Figure 51).

**NOTE: It will not be necessary to remove the headliner from the vehicle.**

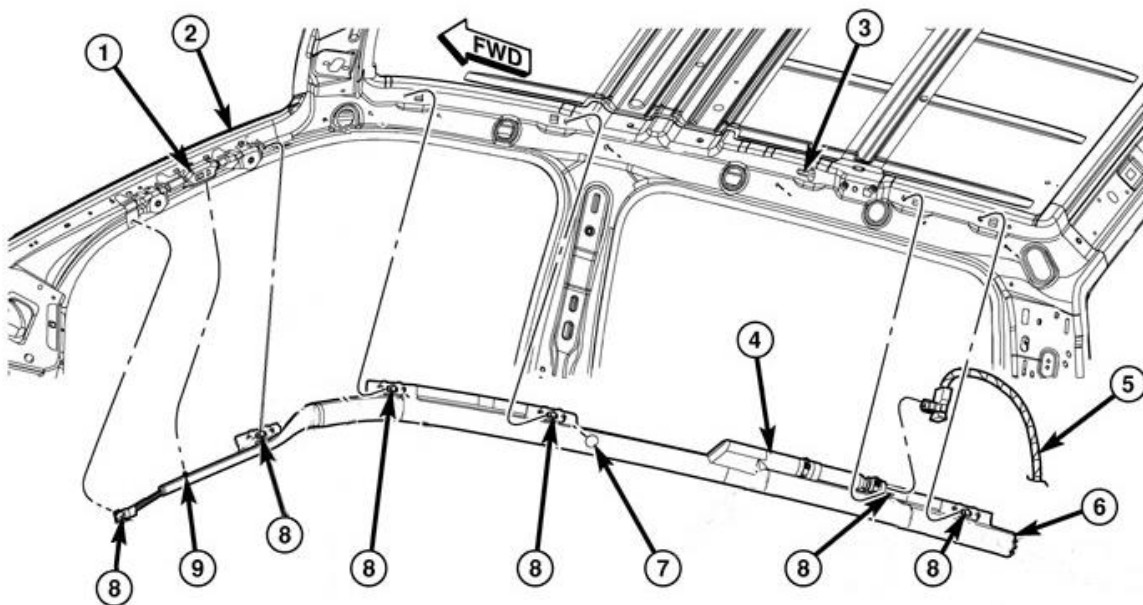
- 25. Obtain the appropriate replacement SABIC(s) for the vehicle based on its VIN.

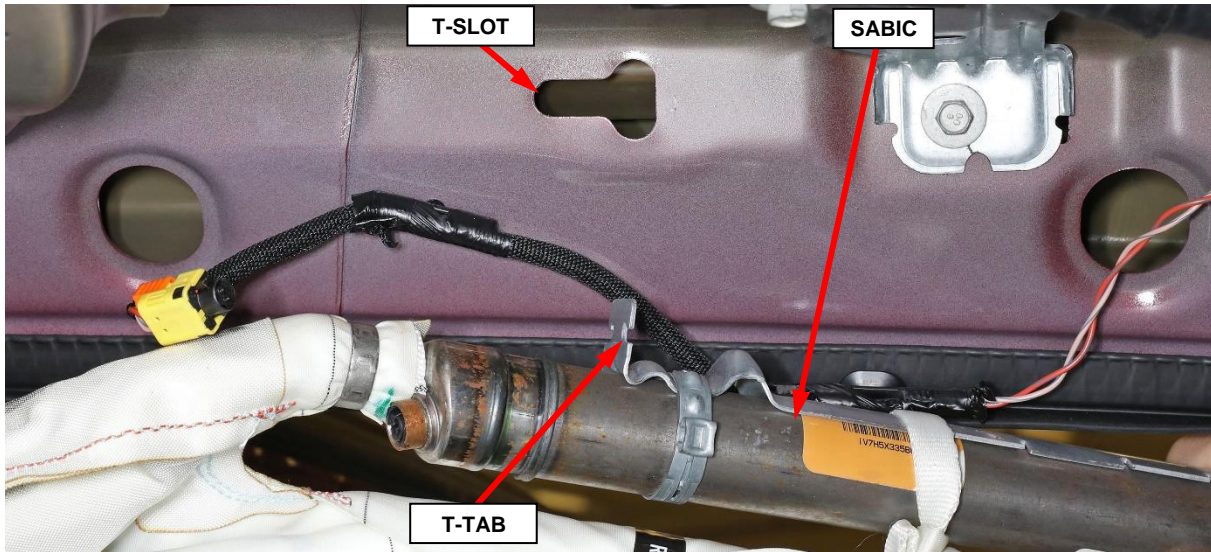


**Figure 51 – Headliner Harness**

**Service Procedure [Continued]**

26. The body wire harness connector (5) is secured by integral latches to the connector receptacle on the inflator (4). Pinch both latches firmly, then pull the connector straight out from the airbag inflator to disconnect it from the connector receptacle (Figure 52).
27. Remove the six bolts (8) that secure the side curtain airbag (6) to the inner roof rail and A-pillar (Figure 52).
28. Disengage the plastic push-in retainer (9) that secures the side curtain airbag tether to the inner A-pillar (1) and the plastic push-in retainer (7) that secures the side curtain airbag to the inner roof rail (Figure 52).
29. Slide the inflator rearward far enough to disengage the T-tab at the front of the inflator bracket from the keyed T-slot in the inner roof rail over the rear door opening (Figure 53).
30. Remove the SABIC (6) from the vehicle as a unit and **DISCARD** following local ordinances and recommended procedures for handling and disposal of Non-Deployed Supplemental Restraints (Figure 52). Provided packaging is not authorized for the transport of the recalled SABIC Module. Parts will need to be either deployed on-site or transported in alternative approved containers.

**Figure 52 – SABIC**

**Service Procedure [Continued]**

**Figure 53 – SABIC Inflator T-Tab and Inner Roof Rail T-Slot**

31. Check to be certain that the spring nuts are properly installed in the inner roof rail and that they are in good condition.
32. Position the **NEW SABIC** (6) into the vehicle as a unit (Figure 52).
33. Insert the T-tab at the front of the inflator bracket into the keyed T-slot in the inner roof rail over the rear door opening and slide the inflator forward to engage it (Figure 53).
34. Engage the plastic push-in retainer (7) that secures the side curtain airbag to the inner roof rail and ensure the tether is not twisted then engage the plastic push-in retainer (9) that secures the side curtain airbag front tether to the assist handle bracket on the inner A-pillar (1) (Figure 52).
35. Working from rear to front, install and tighten the seven bolts (8) that secure the side curtain airbag (6) to the inner roof rail and A-pillar. Tighten the bolts to 7 N·m (62 in. lbs.) (Figure 52).
36. Connect the body wire harness connector (5) for the side curtain airbag to the connector receptacle of the inflator (4). Be certain that each connector is fully engaged in its receptacle by listening carefully for a distinct, audible click as the connector latches snap into place (Figure 52).



**Service Procedure [Continued]**

**CAUTION: Hands should be clean or clean cloth gloves used when handling the headliner to avoid damage to the headliner.**

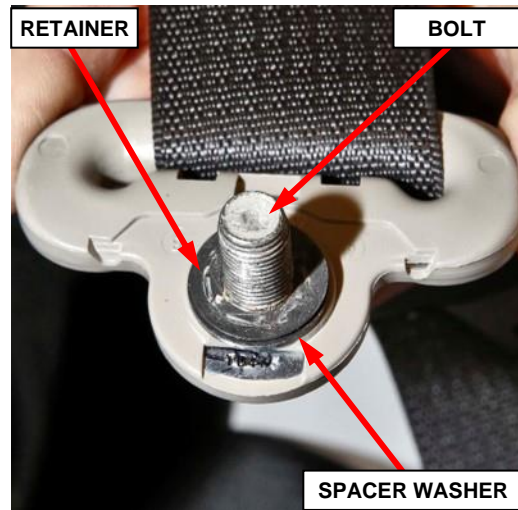
37. Raise the headliner into proper vehicle position and connect any electrical connectors previously disconnected from the headliner (Figure 51).

**CAUTION: Be certain to avoid any wiring or drain tube interference.**

38. Tilt the rear view mirror down to allow it to support the headliner (Figure 50).
39. Reattach any headliner wiring harness clips (3) removed from the A-pillar to allow slack while lowering headliner (Figure 49).
40. Position the visor supports (1) onto the headliner and install the screws into the mounting clips (Figure 47).
41. If equipped with illuminated vanity mirror, connect the wire harness connector.
42. Position the visor to the headliner and install the screws (2) that secure the visor to the roof panel. Tighten the screws to 6 N·m (53 in. lbs.) (Figure 47).
43. If equipped with DVD monitor, connect the DVD monitor electrical connectors (1) (Figure 46). Position the DVD monitor to the roof then install and tighten the screws (2) (Figure 45).
44. Position the upper trim panel to the C-pillar then engage the retaining clips (Figure 44).
45. Install and tighten the screw that secures the C-pillar upper trim panel. Then install the airbag applique (Figure 43).
46. Position the coat hooks (5) onto the headliner and install the screws tightening securely into the mounting clips then close the screw cap fully (Figure 42).

**Service Procedure [Continued]**

47. Install the B-pillar upper trim panel (1) and engage the retaining clips fully (Figure 41).
48. Install the grab handle bolts (3) and tighten to 5 N·m (44 in. lbs.). Close the fastener covers (2) (Figure 41).
49. Remove and **DISCARD** the bolt retainer and the bolt from the seat belt turning loop, save the spacer washer for reuse (Figure 54).
50. Using a **NEW** bolt and reusing the spacer washer, install the turning loop then tighten the bolt to 40 N·m (30 ft. lbs.) (Figure 40).
51. Install the seat belt turning loop cover (Figure 40).
52. Position the B-pillar lower trim panel and engage the retaining clips fully (Figure 39).
53. Position the front and rear door sill scuff plates and engage the retainers

**Figure 54 – Turning Loop Bolt**

**Service Procedure [Continued]**

**WARNING: Do not connect the negative battery cable at this time. The Supplemental Restraint System (SRS) Verification Test procedure should be performed following service of any SRS component.**

**NOTE: The following procedure should be performed using a diagnostic scan tool to verify proper Supplemental Restraint System (SRS) operation following the service or replacement of any SRS component. Refer to the appropriate diagnostic procedures.**

54. During the following test, the negative cable remains disconnected and isolated from the battery, as it was during the Supplemental Restraint System (SRS) component removal and installation procedures.
55. Be certain that the diagnostic scan tool contains the latest version of the proper diagnostic software. Connect the scan tool to the 16-way Data Link Connector (DLC). The DLC is located on the driver side lower edge of the instrument panel, near the steering column opening cover and outboard of the steering column.
56. Transition the status of the ignition switch (also known as the Keyless Ignition Node/KIN or Ignition Node Module/IGNM) to ON and exit the vehicle with the scan tool.
57. Check to be certain that nobody is in the vehicle, then connect the negative cable to the battery.

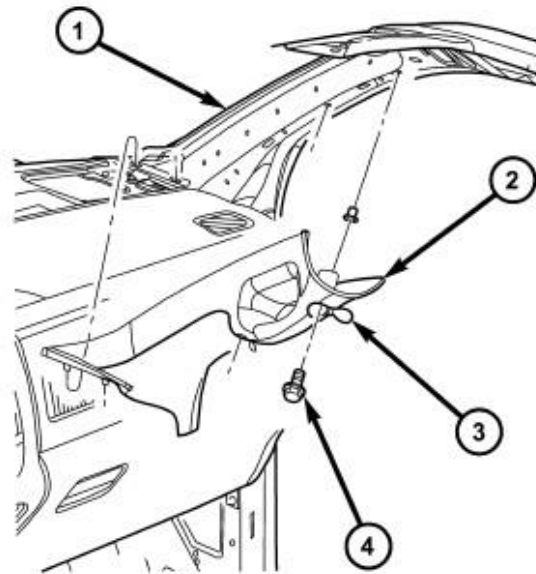
**Service Procedure [Continued]**

58. Using the scan tool, read and record the active (current) Diagnostic Trouble Code (DTC) data.
59. Next, use the scan tool to read and record any stored (historical) DTC data.
60. If any SRS related DTC is found in the previous two steps, refer to the appropriate diagnostic information.
61. Use the scan tool to erase the stored DTC data. If any problems remain, the stored DTC data will not erase. Refer to the appropriate diagnostic information to diagnose any stored DTC that will not erase. If the stored DTC information is successfully erased, continue to the next step.
62. Transition the status of the ignition switch to OFF for about 15 seconds, and then back to ON. Observe the airbag indicator in the instrument cluster. It should light from four to six seconds, and then go out. This indicates that the SRS is functioning normally and that the repairs are complete. If the airbag indicator fails to light, or lights and stays ON, there is still an active SRS fault or malfunction. Refer to the appropriate diagnostic information to diagnose the problem.
63. Install the front seat headrests (Figure 37).
64. Position the locating tab of the A-pillar trim panel (2) into the slot located in the top of the instrument panel (Figure 36).
65. Install the A-pillar trim panel onto the A-pillar (1) and install the two bolts (4). Tighten the bolts to 5 N·m (44 in. lbs.) (Figure 36).
66. Close the two fastener covers (3) located in the A-pillar trim panel (Figure 36).
67. Install the door seals around the door openings.
68. Return the vehicle to the customer or inventory.

**Service Procedure [Continued]**

**D. Mega Cab**

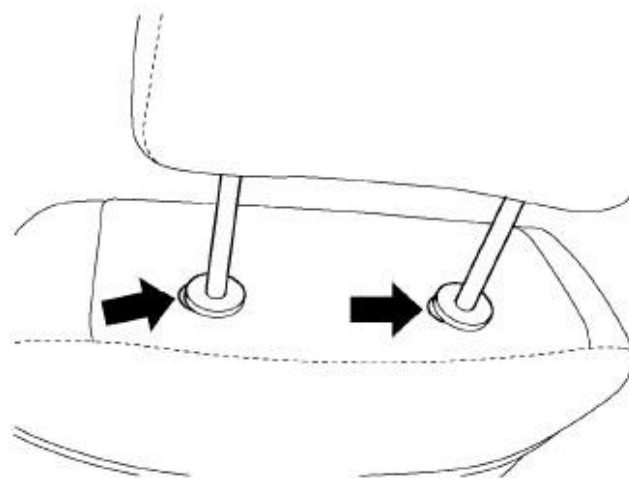
1. Using a small flat-bladed tool, carefully open the two fastener covers (3) located in the A-pillar trim panel (2) (Figure 55).
  
2. Remove the two bolts (4) that secure the A-pillar trim panel to the A-pillar (1) and remove the trim panel (Figure 55).



80d407a9

**Figure 55 – A-Pillar**

3. Push in the buttons on front seat headrest sleeves then pull the headrest up and remove (Figure 56).



812oddd3

**Figure 56 – Head Rest**

4. Fold the seats forward.

**Service Procedure [Continued]**

5. Release the front and rear door sill scuff plates on either side of the B-pillar lower trim panel to allow for removal of the B-pillar lower trim panel (Figure 57).



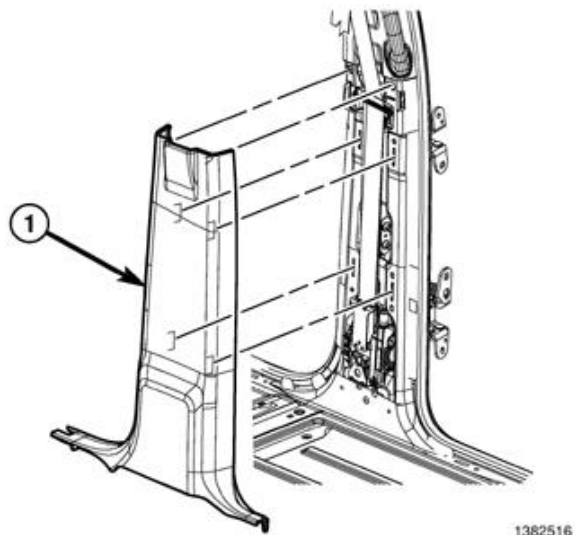
**Front Door Sill**



**Rear Door Sill**

**Figure 57 – Door Sill Scuff Plates**

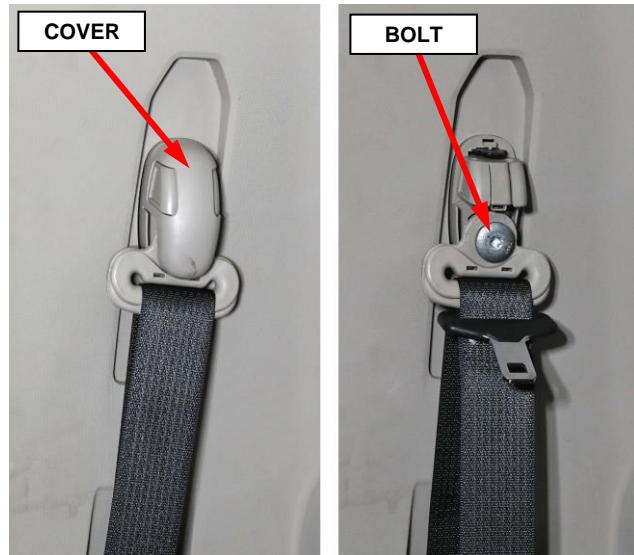
6. Release the retaining clips and remove the B-pillar lower trim panel to allow for removal of the B-pillar upper trim panel (Figure 58).



**Figure 58 – B-Pillar Lower Trim Panel**

**Service Procedure [Continued]**

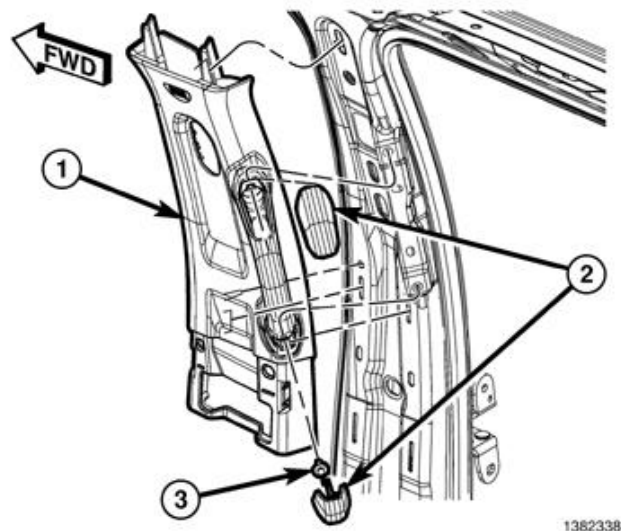
7. On the B-pillar, separate the seatbelt turning loop cover then remove the turning loop bolt (Figure 59).



**Figure 59 – Seat Belt Turning Loop**

8. On the B-pillar, use a small flat-bladed tool to carefully open the two fastener covers (2) located on the grab handle (Figure 60).

9. Remove the two bolts (3) that secure the grab handle to the B-pillar (Figure 60).



**Figure 60 – B-Pillar Upper Trim Panel**

10. Using a trim stick C-4755 or equivalent, release the retaining clips that secure the B-pillar upper trim panel (1) then position the trim panel out of the way. It is not necessary to remove the seat belt from the trim panel (Figure 60).

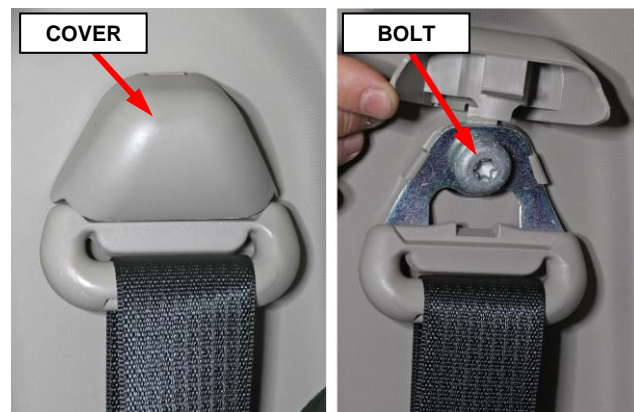
**Service Procedure [Continued]**

11. Fold the rear seat backs down.
12. Release the upper retaining clips of the lower C-pillar trim panel to allow for removal of the upper C-pillar trim panel (Figure 61).



**Figure 61 – C-Pillar Lower Trim Panel**

13. On the C-pillar, lift the seat belt turning loop cover then remove the turning loop bolt (Figure 62).

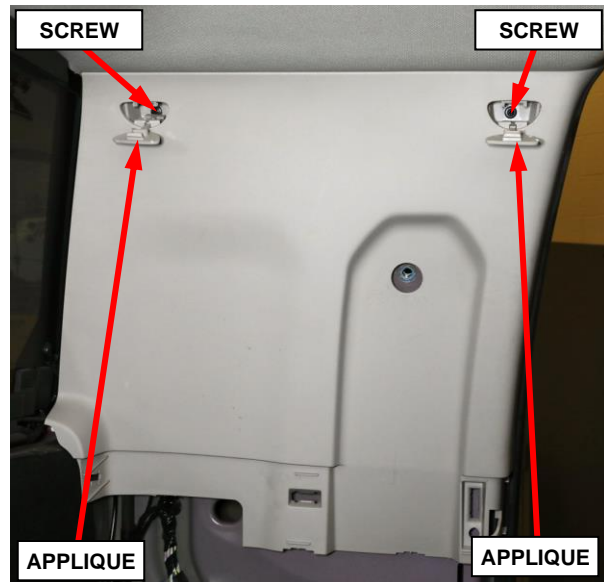


**Figure 62 – Seat Belt Turning Loop**



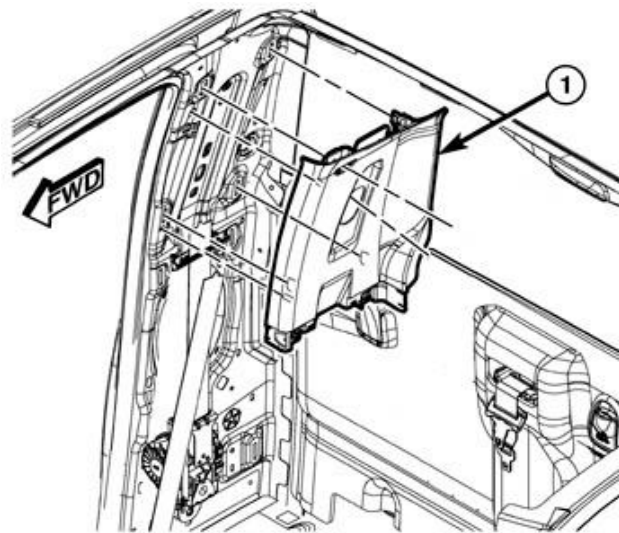
**Service Procedure [Continued]**

14. Using a trim stick or equivalent, release the B-pillar airbag applique then remove the screw that secures the upper trim panel (Figure 63).



**Figure 63 – C-Pillar Upper Trim Panel Fasteners**

15. Release the retaining clips and remove the C-pillar upper trim panel (1) (Figure 64).



**Figure 64 – C-Pillar Upper Trim Panel**

16. Recline the front seat backs to allow for room to lower the headliner.

**Service Procedure [Continued]**

17. Disconnect and isolate the negative battery cable. If equipped with an Intelligent Battery Sensor (IBS), disconnect the IBS connector first before disconnecting the negative battery cable. Wait two minutes for the system capacitor to discharge before further service.

**WARNING:** To avoid serious or fatal injury on vehicles equipped with airbags, disable the Supplemental Restraint System (SRS) before attempting any steering wheel, steering column, airbag, seat belt tensioner, impact sensor or instrument panel component diagnosis or service. Disconnect and isolate the battery negative (ground) cable, then wait two minutes for the system capacitor to discharge before performing further diagnosis or service. This is the only sure way to disable the SRS. Failure to take the proper precautions could result in accidental airbag deployment.

**WARNING:** To avoid serious or fatal injury when removing a deployed airbag, rubber gloves, eye protection, and a long-sleeved shirt should be worn. There may be deposits on the airbag unit and other interior surfaces. In large doses, these deposits may cause irritation to the skin and eyes.

**WARNING:** To avoid serious or fatal injury, use extreme care to prevent any foreign material from entering the side curtain airbag, or becoming entrapped between the side curtain airbag cushion and the headliner. Failure to observe this warning could result in occupant injuries upon airbag deployment.

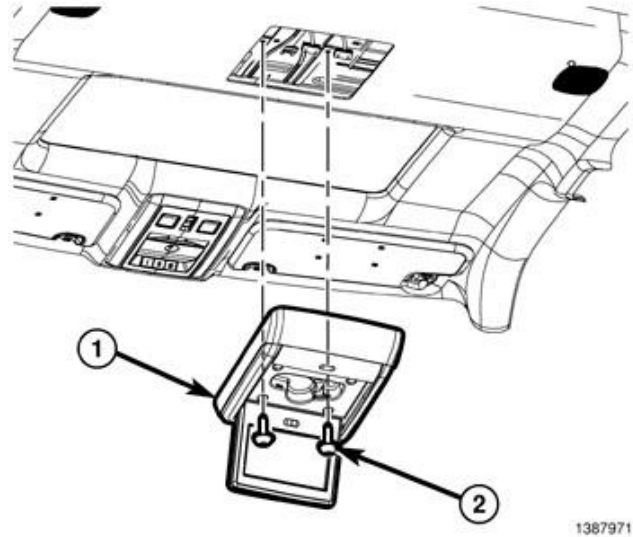
**NOTE:** The following procedure is for replacement of an ineffective or damaged side curtain airbag (also known as Side Air Bag Inflatable Curtain/SABIC). If the airbag is ineffective or damaged, but not deployed, review local ordinances regarding recommended procedures for handling and disposal of Non-Deployed Supplemental Restraints.

**NOTE:** If a side curtain airbag is being removed, but has not been deployed, the headliner does not need to be removed from the passenger compartment. Lowering the headliner and resting it on the seat backs will allow enough clearance to remove the side curtain airbag from the vehicle.

**Service Procedure [Continued]**

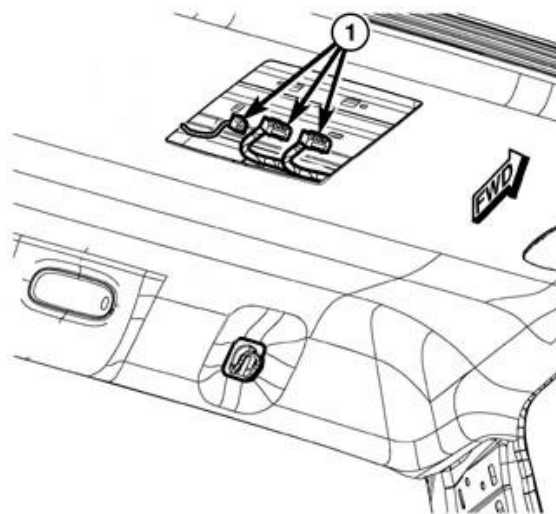
**CAUTION:** Hands should be clean or clean cloth gloves used when handling the visors and headliner to avoid marks or damage.

18. If equipped with DVD monitor, remove the screws (2) and separate the monitor (1) from the roof (Figure 65).



**Figure 65 – Rear Seat DVD Monitor**

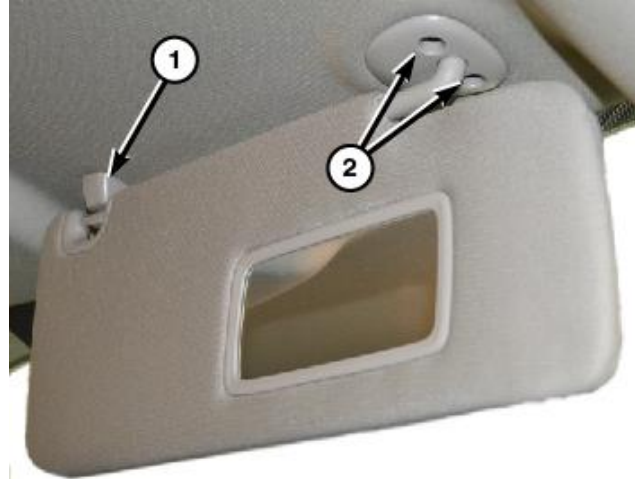
19. If equipped with DVD monitor, disconnect the electrical connectors (1) (Figure 66).



**Figure 66 – DVD Monitor Electrical Connectors**

**Service Procedure [Continued]**

20. Separate the visor from the support (1) then remove the screw and remove the visor support (Figure 67).



**Figure 67 – Visors**

21. Remove the visor screws (2) then remove the visor (Figure 78).

Using a small flat bladed tool or equivalent, release the retaining tabs (1) and separate the visor from the headliner (Figure 68).

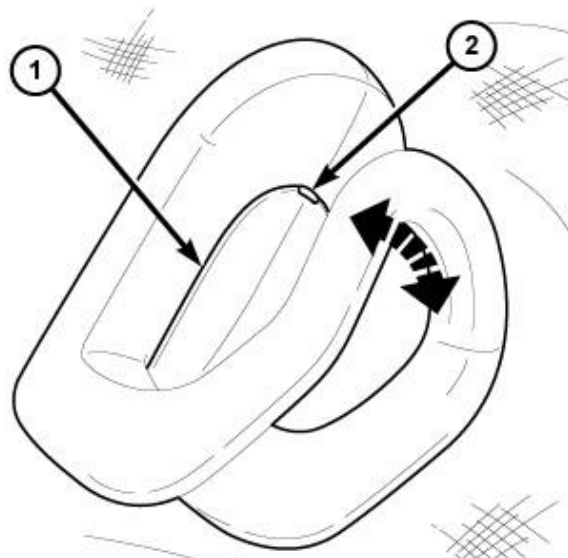


**Figure 68 – Visors**

22. Disconnect the visor electrical connector if equipped.

**NOTE: In some cases, the wire harness for the visor vanity mirror may be glued to the top side of the headliner and may be a little difficult to release.**

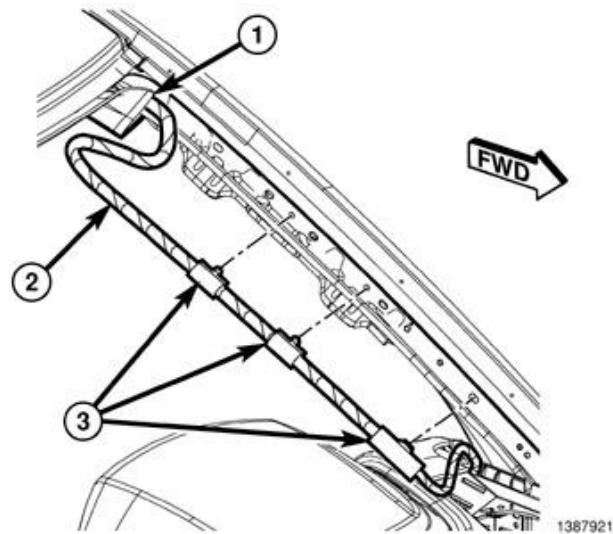
23. Using a small flat bladed tool, open the coat hook screw cover (2) then remove the screw and coat hook (Figure 69).



**Figure 69 – Coat Hook**

**Service Procedure [Continued]**

24. As necessary, release the headliner wiring harness clips (3) from the A-pillar to allow enough wiring harness slack for lowering the headliner (Figure 70).

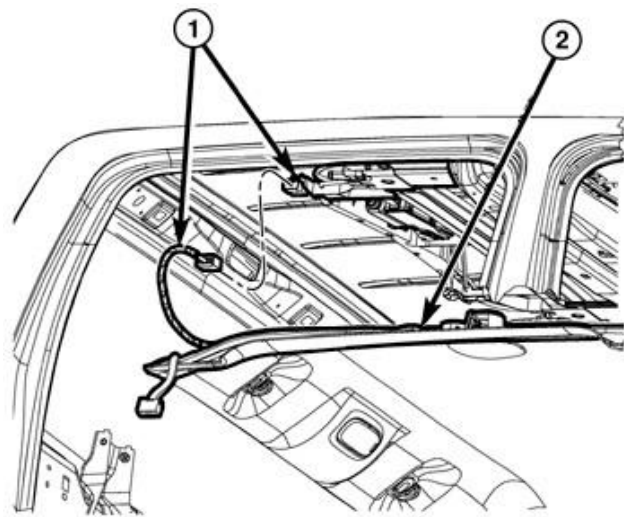


**Figure 70 – Headliner Harness**

25. Release the door seals from the door openings to allow for lowering of the headliner.

26. Carefully lower the headliner (2) allowing it to rest on the seat backs and instrument panel (Figure 71).

**CAUTION: Disconnect any wiring harness electrical connectors (1) as necessary to allow enough wiring harness slack while lowering headliner. It will not be necessary to remove the headliner from the vehicle (Figure 71).**

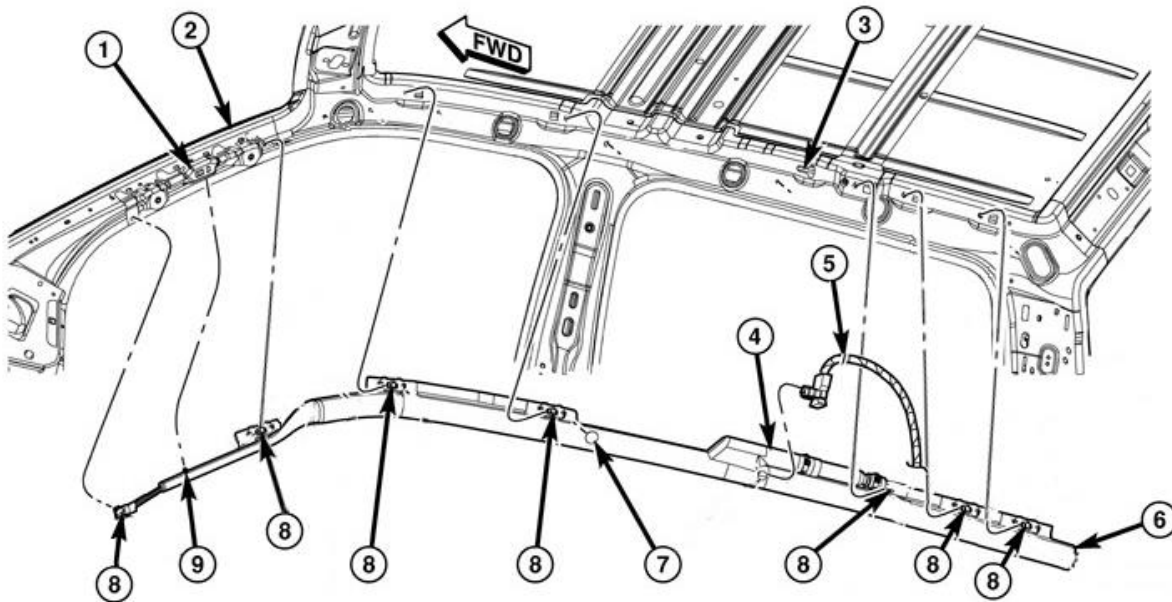


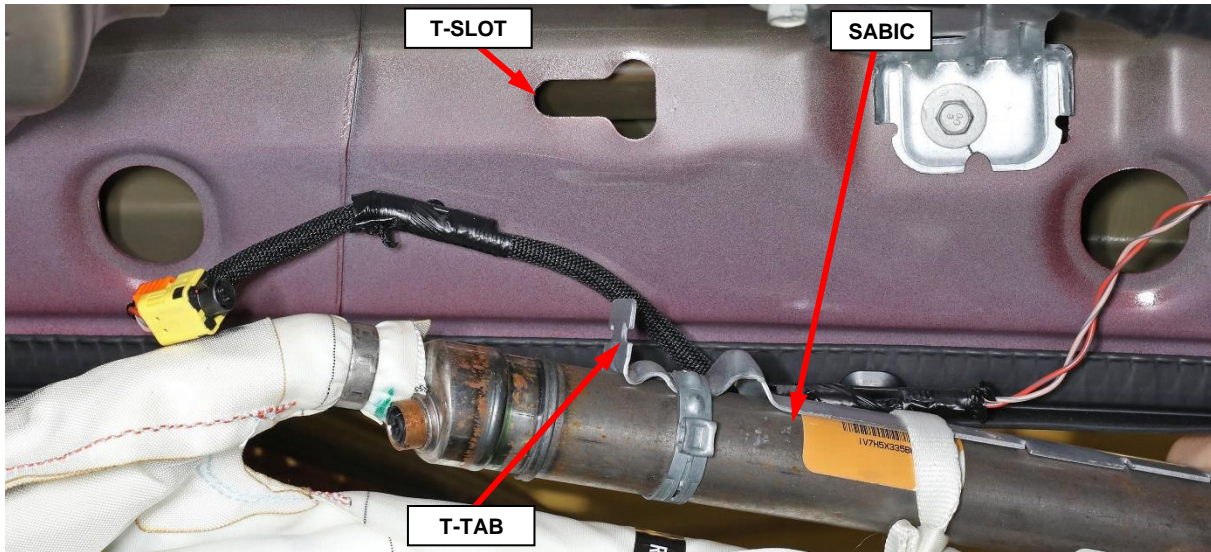
**Figure 71 – Headliner Harness**

27. Obtain the appropriate replacement SABIC(s) for the vehicle based on its VIN.

**Service Procedure [Continued]**

28. The body wire harness connector (5) is secured by integral latches to the connector receptacle on the inflator (4). Pinch both latches firmly, then pull the connector straight out from the airbag inflator to disconnect it from the connector receptacle (Figure 72).
29. Remove the seven bolts (8) that secure the side curtain airbag (6) to the inner roof rail and A-pillar (Figure 72).
30. Disengage the plastic push-in retainer (9) that secures the side curtain airbag tether to the inner A-pillar (1) and the plastic push-in retainer (7) that secures the side curtain airbag to the inner roof rail (Figure 72).
31. Slide the inflator rearward far enough to disengage the T-tab at the front of the inflator bracket from the keyed T-slot in the inner roof rail over the rear door opening (Figure 73).
32. Remove the SABIC (6) from the vehicle as a unit and **DISCARD** following local ordinances and recommended procedures for handling and disposal of Non-Deployed Supplemental Restraints (Figure 72). Provided packaging is not authorized for the transport of the recalled SABIC Module. Parts will need to be either deployed on-site or transported in alternative approved containers.

**Figure 72 – SABIC**

**Service Procedure [Continued]**

**Figure 73 – SABIC Inflator T-Tab and Inner Roof Rail T-Slot**

33. Check to be certain that the spring nuts are properly installed in the inner roof rail and that they are in good condition.
34. Position the **NEW SABIC** (6) into the vehicle as a unit (Figure 72).
35. Insert the T-tab at the front of the inflator bracket into the keyed T-slot in the inner roof rail over the rear door opening and slide the inflator forward to engage it (Figure 73).
36. Engage the plastic push-in retainer (7) that secures the side curtain airbag to the inner roof rail and ensure the tether is not twisted then engage the plastic push-in retainer (9) that secures the side curtain airbag front tether to the assist handle bracket on the inner A-pillar (1) (Figure 72).
37. Working from rear to front, install and tighten the seven bolts (8) that secure the side curtain airbag (6) to the inner roof rail and A-pillar. Tighten the bolts to 7 N·m (62 in. lbs.) (Figure 72).
38. Connect the body wire harness connector (5) for the side curtain airbag to the connector receptacle of the inflator (4). Be certain that each connector is fully engaged in its receptacle by listening carefully for a distinct, audible click as the connector latches snap into place (Figure 72).

**Service Procedure [Continued]**

**CAUTION: Hands should be clean or clean cloth gloves used when handling the headliner to avoid damage to the headliner.**

39. Raise the headliner into proper vehicle position and connect any electrical connectors previously disconnected from the headliner (Figure 71).

**CAUTION: Be certain to avoid any wiring or drain tube interference.**

40. Position the coat hooks (5) onto the headliner and install the screws tightening securely into the mounting clips then close the screw cap fully (Figure 69).
41. Position the visor supports (1) onto the headliner and install the screws into the mounting clips (Figure 67).
42. If equipped with illuminated vanity mirror, connect the wire harness connector.
43. Position the visor to the headliner and install the screws (2) that secure the visor to the roof panel. Tighten the screws to 6 N·m (53 in. lbs.) (Figure 67).
44. Reattach any headliner wiring harness clips (3) removed from the A-pillar to allow slack while lowering headliner (Figure 70).
45. If equipped with DVD monitor, connect the DVD monitor electrical connectors (1) (Figure 66). Position the DVD monitor to the roof then install and tighten the screws (2) (Figure 65).

**WARNING: Do not connect the negative battery cable at this time. The Supplemental Restraint System (SRS) Verification Test procedure should be performed following service of any SRS component.**

**NOTE: The following procedure should be performed using a diagnostic scan tool to verify proper Supplemental Restraint System (SRS) operation following the service or replacement of any SRS component. Refer to the appropriate diagnostic procedures.**

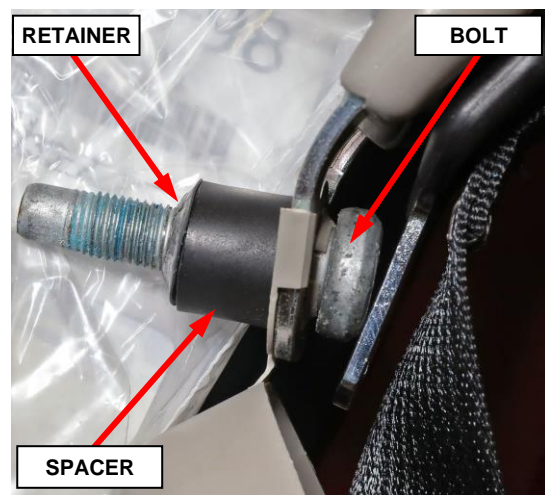


**Service Procedure [Continued]**

46. During the following test, the negative cable remains disconnected and isolated from the battery, as it was during the Supplemental Restraint System (SRS) component removal and installation procedures.
47. Be certain that the diagnostic scan tool contains the latest version of the proper diagnostic software. Connect the scan tool to the 16-way Data Link Connector (DLC). The DLC is located on the driver side lower edge of the instrument panel, near the steering column opening cover and outboard of the steering column.
48. Transition the status of the ignition switch (also known as the Keyless Ignition Node/KIN or IGnition Node Module/IGNM) to ON and exit the vehicle with the scan tool.
49. Check to be certain that nobody is in the vehicle, then connect the negative cable to the battery.
50. Using the scan tool, read and record the active (current) Diagnostic Trouble Code (DTC) data.
51. Next, use the scan tool to read and record any stored (historical) DTC data.
52. If any SRS related DTC is found in the previous two steps, refer to the appropriate diagnostic information.
53. Use the scan tool to erase the stored DTC data. If any problems remain, the stored DTC data will not erase. Refer to the appropriate diagnostic information to diagnose any stored DTC that will not erase. If the stored DTC information is successfully erased, continue to the next step.
54. Transition the status of the ignition switch to OFF for about 15 seconds, and then back to ON. Observe the airbag indicator in the instrument cluster. It should light from four to six seconds, and then go out. This indicates that the SRS is functioning normally and that the repairs are complete. If the airbag indicator fails to light, or lights and stays ON, there is still an active SRS fault or malfunction. Refer to the appropriate diagnostic information to diagnose the problem.

**Service Procedure [Continued]**

55. Raise the front seat backs and position the seats forward.
56. Install the C-pillar upper trim panel (1) and engage the retaining clips fully (Figure 64).
57. Install and tighten the screws that secure the C-pillar upper trim panel then install the airbag applique covers (Figure 63).
58. Remove and **DISCARD** the bolt retainer and the bolt from the seat belt turning loop, save the spacer for reuse (Figure 74).
59. Using a **NEW** bolt and reusing the spacer washer, install the turning loop then tighten the bolt to 40 N·m (30 ft. lbs.) (Figure 62).
60. Install the seat belt turning loop cover (Figure 62).
61. Position the lower C-pillar trim panel and engage the retaining clips fully (Figure 61).

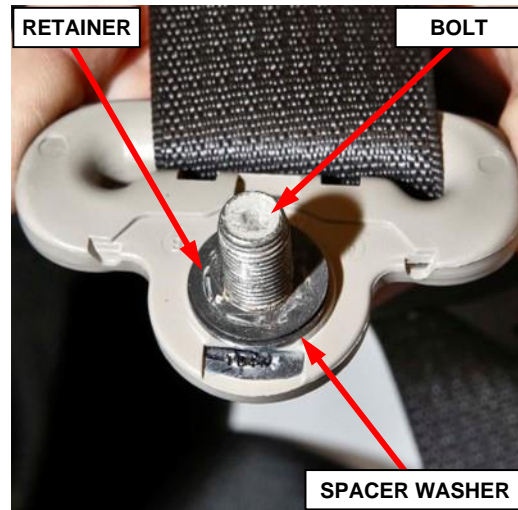
**Figure 74 – Turning Loop Bolt**

**NOTE: Ensure that all C-pillar fasteners are installed/engaged properly.**

62. Install the B-pillar upper trim panel (1) and engage the retaining clips fully (Figure 60).
63. Install the grab handle bolts and tighten to 5 N·m (44 in. lbs.). Close the fastener covers (2) (Figure 60).

**Service Procedure [Continued]**

64. Remove and **DISCARD** the bolt retainer and the bolt from the seat belt turning loop, save the spacer washer for reuse (Figure 75).
65. Using a **NEW** bolt and reusing the spacer washer, install the turning loop then tighten the bolt to 40 N·m (30 ft. lbs.) (Figure 59).
66. Install the seat belt turning loop cover (Figure 59).
67. Position the B-pillar lower trim panel and engage the retaining clips fully (Figure 58).
68. Position the front and rear door sill scuff plates and engage the retainers (Figure 57).
69. Install the front seat headrests (Figure 56).
70. Position the locating tab of the A-pillar trim panel (2) into the slot located in the top of the instrument panel (Figure 55).
71. Install the A-pillar trim panel onto the A-pillar (1) and install the two bolts (4). Tighten the bolts to 5 N·m (44 in. lbs.) (Figure 55).
72. Close the two fastener covers (3) located in the A-pillar trim panel (Figure 55).
73. Install the door seals around the door openings.
74. Return the vehicle to the customer or inventory.

**Figure 75 – Turning Loop Bolt**

**Completion Reporting and Reimbursement**

Claims for vehicles that have been serviced must be submitted on the DealerCONNECT Claim Entry Screen located on the Service tab. Claims paid will be used by FCA to record recall service completions and provide dealer payments.

Use the following labor operation numbers and time allowances:

	<b>Labor Operation Number</b>	<b>Time Allowance</b>
Replace Two SABICs (Standard Cab)	23-Y5-51-82	1.6 hours
Replace Two SABICs (Crew/Quad Cab)	23-Y5-51-83	2.0 hours
Replace Two SABICs (Mega Cab)	23-Y5-51-84	2.7 hours

Add the cost of the recall parts plus applicable dealer allowance to your claim.

**NOTE: See the Warranty Administration Manual, Recall Claim Processing Section, for complete recall claim processing instructions.**

**Dealer Notification**

To view this notification on DealerCONNECT, select “Global Recall System” on the Service tab, then click on the description of this notification.

**Owner Notification and Service Scheduling**

All involved vehicle owners known to FCA are being notified of the service requirement by first class mail. They are requested to schedule appointments for this service with their dealers. A generic copy of the owner letter is attached.

**Vehicle Lists, Global Recall System, VIP and Dealer Follow Up**

All involved vehicles have been entered into the DealerCONNECT Global Recall System (GRS) and Vehicle Information Plus (VIP) for dealer inquiry as needed.

GRS provides involved dealers with an updated VIN list of their incomplete vehicles. The owner's name, address and phone number are listed if known. Completed vehicles are removed from GRS within several days of repair claim submission.

To use this system, click on the “**Service**” tab and then click on “**Global Recall System.**” Your dealer's VIN list for each recall displayed can be sorted by: those vehicles that were unsold at recall launch, those with a phone number, city, zip code, or VIN sequence.

**Dealers must perform this repair on all unsold vehicles before retail delivery.** Dealers should also use the VIN list to follow up with all owners to schedule appointments for this repair.

*Recall VIN lists may contain confidential, restricted owner name and address information that was obtained from the Department of Motor Vehicles of various states. Use of this information is permitted for this recall only and is strictly prohibited from all other use.*

**Additional Information**

If you have any questions or need assistance in completing this action, please contact your Service and Parts District Manager.

Customer Services / Field Operations  
FCA US LLC

This notice applies to your vehicle.

[Model Year and Model]

VIN XXXXXXXXXXXXXXXXXXXX

Y55/NHTSA 21V-632

LOGO

VEHICLE PICTURE

#### YOUR SCHEDULING OPTIONS

- 1. RECOMMENDED OPTION**  
Call your authorized Chrysler / Dodge / Jeep® / RAM] Dealership
- 2. Call the FCA Recall Assistance Center at 1-800-853-1403.** An agent can confirm part availability and help schedule an appointment
- 3. Visit recalls.mopar.com, scan the QR code below, or download the Mopar Owner's Companion App.**

QR Code

Get access to recall notifications, locate your nearest dealer, and more through this website or Mopar Owner's Companion App. You will be asked to provide your Vehicle Identification Number (VIN) to protect and verify your identity. The last eight characters of your VIN are provided above.

#### DEALERSHIP INSTRUCTIONS

Please reference Safety Recall Y55.

# IMPORTANT SAFETY RECALL

## Side Air Bag Inflatable Curtain Inflator

Dear [Name],

This notice is sent to you in accordance with the National Traffic and Motor Vehicle Safety Act.

FCA US has decided that a defect, which relates to motor vehicle safety, exists in certain [2015 Model Year (DS) Ram 1500 Pickup, (DJ) Ram 2500 Pickup, and (D2) Ram 3500 Pickup] vehicles.

It is extremely important to take steps now to repair your vehicle to ensure the safety of you and your passengers.

#### WHY DOES MY VEHICLE NEED REPAIRS?

The Side Air Bag Inflatable Curtain (SABIC) inflator on your vehicle <sup>[1]</sup> may rupture. A SABIC inflator rupture may result in compressed gas rapidly escaping from the inflator and material potentially being propelled into the vehicle. **Material being propelled into the vehicle may cause injury to vehicle occupants.**

#### HOW DO I RESOLVE THIS IMPORTANT SAFETY ISSUE?

FCA US will repair your vehicle <sup>[2]</sup> free of charge (parts and labor). To do this, your dealer will replace both SABICs. The estimated repair time is 3 hours. In addition, your dealer will require your vehicle for proper check-in, preparation, and check-out during your visit, which may require more time. Your time is important to us, so we recommend that you schedule a service appointment to minimize your inconvenience. Please bring this letter with you to your dealership.

**TO SCHEDULE YOUR FREE REPAIR,  
CALL YOUR CHRYSLER, DODGE, JEEP OR RAM DEALER TODAY**

#### WHAT IF I ALREADY PAID TO HAVE THIS REPAIR COMPLETED?

If you have already experienced this specific condition and have paid to have it repaired, you may visit [www.fcarecallreimbursement.com](http://www.fcarecallreimbursement.com) to submit your reimbursement request online. <sup>[3]</sup> Once we receive and verify the required documents, reimbursement will be sent to you within 60 days. If you have had previous repairs performed and/or already received reimbursement, you may still need to have the recall repair performed.

We apologize for any inconvenience, but are sincerely concerned about your safety. Thank you for your attention to this important matter.

Customer Assistance/Field Operations  
FCA US LLC



**Mr. Mrs. Customer**  
**1234 Main Street**  
**Hometown, MI 48371**

[1] If you no longer own this vehicle, please help us update our records. Call the FCA Recall Assistance Center at 1-800-853-1403 to update your information.

[2] If your dealer fails or is unable to remedy this defect without charge and within a reasonable time, you may submit a written complaint to the Administrator, National Highway Traffic Safety Administration, 1200 New Jersey Ave., S.E., Washington, DC 20590, or you can call the toll-free Vehicle Safety Hotline at 1-888-327-4236 (TTY 1-800-424-9153), or go to [safercar.gov](http://safercar.gov).

[3] You can also mail in your original receipts and proof of payment to the following address for reimbursement consideration: FCA Customer Assistance, P.O. Box 21-8004, Auburn Hills, MI 48321-8007, Attention: Recall Reimbursement.

Note to lessors receiving this recall notice: Federal regulation requires that you forward this recall notice to the lessee within 10 days.

This notice applies to your vehicle,

[Model Year and Model]

VIN XXXXXXXXXXXXXXXXXXXX

Y55/NHTSA 21V-632

LOGO

VEHICLE PICTURE

#### YOUR SCHEDULING OPTIONS

1. Visit [recalls.mopar.com](https://recalls.mopar.com) to sign up for email or SMS notifications for when remedy parts become available. You will be asked to provide your Vehicle Identification Number (VIN), provided above
2. Scan below using your smartphone or tablet to sign up to be notified when remedy parts become available

QR Code

3. Wait for FCA US to contact you again, by mail, with a follow-up recall notice when remedy parts are available
4. Call the FCA Recall Assistance Center at 1-800-853-1403. An agent can sign you up to be notified when remedy parts become available, or answer any other questions you may have

**DEALERSHIP INSTRUCTIONS**  
Please reference Safety Recall Y55.

# IMPORTANT SAFETY RECALL

## Side Air Bag Inflatable Curtain

Dear [Name],

This notice is sent to you in accordance with the National Traffic and Motor Vehicle Safety Act.

FCA US has decided that a defect, which relates to motor vehicle safety, exists in certain [2015-2020 Model Year (DS) Ram 1500 Pickup, 2015-2016 Model Year (DJ) Ram 2500 Pickup, (D2) Ram 3500 Pickup, and 2016 Model Year (DF) Ram 3500 10K lbs. Cab Chassis] vehicles.

#### WHY DOES MY VEHICLE NEED REPAIRS?

The Side Air Bag Inflatable Curtain (SABIC) inflator on your vehicle <sup>[1]</sup> may rupture. A SABIC inflator rupture may result in compressed gas rapidly escaping from the inflator and material potentially being propelled into the vehicle. **Material being propelled into the vehicle may cause injury to vehicle occupants.**

#### HOW DO I RESOLVE THIS IMPORTANT SAFETY ISSUE?

**The remedy for this condition is not currently available.** We are making every effort to finalize the remedy as quickly as possible, and will service your vehicle free of charge (parts and labor).

FCA US will contact you again, by mail, with a follow-up recall notice when the remedy is available. Once you receive your follow-up notice, simply contact your Chrysler, Jeep®, Dodge or RAM dealer right away to schedule a service appointment <sup>[2]</sup>. Additional options for your next steps are included on the left side of this notification. We appreciate your patience.

#### WHAT IF I ALREADY PAID TO HAVE THIS REPAIR COMPLETED?

If you have already experienced this specific condition and have paid to have it repaired, you may visit [www.fcarecallreimbursement.com](https://www.fcarecallreimbursement.com) to submit your reimbursement request online <sup>[3]</sup>. Once we receive and verify the required documents, reimbursement will be sent to you within 60 days. If you have had previous repairs performed and/or already received reimbursement, you may still need to have the recall repair performed.

We apologize for any inconvenience, but are sincerely concerned about your safety. Thank you for your attention to this important matter.

Customer Assistance/Field Operations  
FCA US LLC





**Mr. Mrs. Customer**  
**1234 Main Street**  
**Hometown, MI 48371**

[1] If you no longer own this vehicle, please help us update our records. Call the FCA Recall Assistance Center at 1-800-853-1403 to update your information.

[2] If your dealer fails or is unable to remedy this defect without charge and within a reasonable time, you may submit a written complaint to the Administrator, National Highway Traffic Safety Administration, 1200 New Jersey Ave., S.E., Washington, DC 20590, or you can call the toll-free Vehicle Safety Hotline at 1-888-327-4236 (TTY 1-800-424-9153), or go to [safercar.gov](http://safercar.gov).

[3] You can also mail in your original receipts and proof of payment to the following address for reimbursement consideration: FCA Customer Assistance, P.O. Box 21-8004, Auburn Hills, MI 48321-8007, Attention: Recall Reimbursement.

Note to lessors receiving this recall notice: Federal regulation requires that you forward this recall notice to the lessee within 10 days.