



Revision (2) February 2026

Dealer Service Instructions for:

Safety Recall Y63 / NHTSA 21V-632 Side Air Bag Inflatable Curtain Inflator

NOTE: Revised Parts Information and Parts Disposal sections.

Remedy Available

2015-2020 (DS) Ram 1500 Pickup
2015-2016 (DJ) Ram 2500 Pickup
2015-2016 (D2) Ram 3500 Pickup
2016 (DF) Ram 3500 10K LB Cab Chassis

NOTE: Some vehicles above may have been identified as not involved in this recall and therefore have been excluded from this recall.

IMPORTANT: Some of the involved vehicles may be in dealer used vehicle inventory. Dealers should complete this recall service on these vehicles before retail delivery. Dealers should also perform this recall on vehicles in for service. Involved vehicles can be determined by using the VIP inquiry process.

Subject

The Side Air Bag Inflatable Curtain (SABIC) inflator on about 33,000 of the above vehicles may rupture. A SABIC inflator rupture may result in compressed gas rapidly escaping from the inflator and material potentially being propelled into the vehicle. Material being propelled into the vehicle may cause injury to vehicle occupants.

Repair

Inspect and if necessary, replace one or both SABICs as needed.

Parts Information

NOTE: Do not destroy the replacement inflator packaging, it will be used to return the original inflator for disposal.

NOTE: Seat belt turning loop bolts below are REQUIRED for every vehicle in order to perform SABIC inspection and replacement.

<u>Part Number</u>	<u>Required</u>	<u>Description</u>
06036773AA	2	Bolt – Seatbelt Turning Loop (ALL cab configurations)
06036690AA	2	Bolt – Seatbelt Turning Loop (Quad cab and Mega cab ONLY)

NOTE: SABIC replacement will NOT be required on all vehicles and the traceability number will require verification as described in the Service Procedure. Check the traceability number and replace ONLY those SABICs that the lookup tool indicates replacement is necessary.

<u>Part Number</u>	<u>Description</u>
CSSLY551AA	Right – Crew
CSSLY552AA	Left – Crew
CSSLY553AA	Right - Quad
CSSLY554AA	Left – Quad
CSSLY555AA	Right - Mega
CSSLY556AA	Left - Mega
CSSLY557AA	Right - Standard
CSSLY558AA	Left - Standard

Parts Disposal (Optional)

Original Mopar inflator packaging must be used for the following disposal procedure.

International (including Mexico), Hawaii, Alaska, Puerto Rico, and US Virgin Islands: No part return available. Destroy the original inflator using locally approved methods.

Airbag Disposal Return Process

****Only Airbag part numbers included in this Recall Campaign are eligible****

Upon Accumulating 52 boxes per pallet (shrink-wrapped or strapped)
(Multiple Pallets are acceptable)

Please Email RXO to Schedule LTL Pickup:

- **US Domestic Collections - scfieldaction.14305@rxo.com**
- **Canada International Collections - sctakatarestraints_international@rxo.com**

No response after 48 - 72 hours call the escalation number, (210) 317-6436 for further assistance.

Items to have available in email request:

- 1) Dealer Code
- 2) Quantity Pallets/Overpacks with # of boxes on each pallet
- 3) Dealer E-mail Address for Shipping Documentation to be received
- 4) Liftgate Service - Yes or No

Alternate Transportation

Dealers should attempt to minimize customer inconvenience by placing the owner in a loaner vehicle if the vehicle must be held overnight.

Service Procedure [Continued]

A. Standard Cab

1. Using a small flat-bladed tool, carefully open the two fastener covers (3) located in the A-pillar trim panel (2) (Figure 1).

2. Remove the two bolts (4) that secure the A-pillar trim panel to the A-pillar (1) and remove the trim panel (Figure 1).

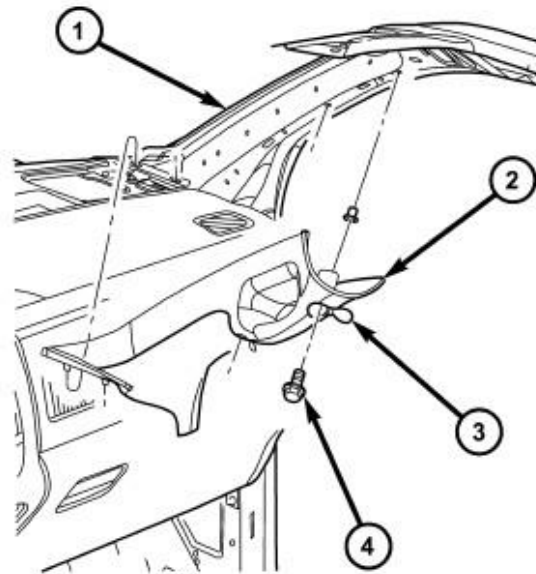

80d407a9

Figure 1 – A-Pillar

3. Push in the buttons on front seat headrest sleeves then pull the headrest up and remove (Figure 2).

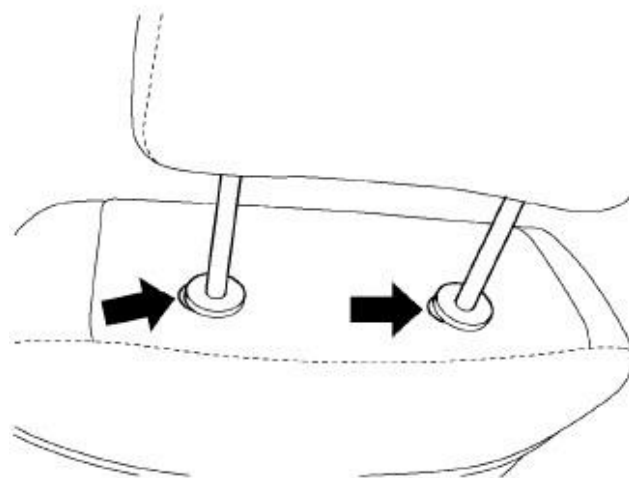

812oddd3

4. Fold the seats forward.

Figure 2 – Front Seat Head Rest

Service Procedure [Continued]

5. Release the upper retaining clips of the B-pillar lower trim panel to allow for removal of the B-pillar upper trim panel (Figure 3).



Figure 3 – B-Pillar Lower Trim Panel

6. Separate the seatbelt turning loop cover then remove the turning loop bolt (Figure 4).

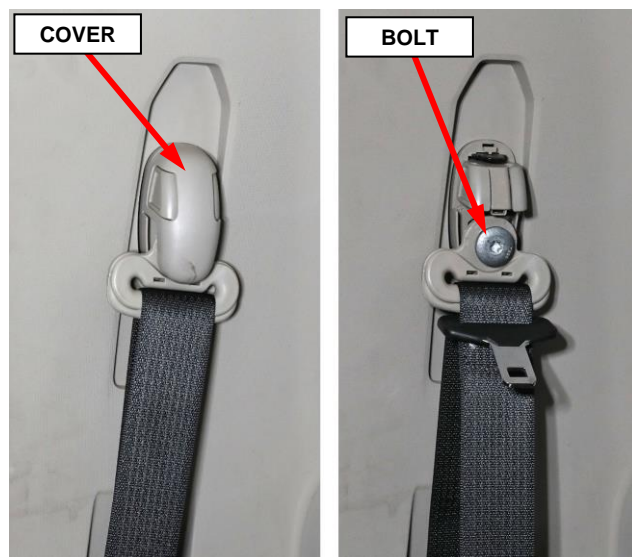

Figure 4 – Seat Belt Turning Loop

Service Procedure [Continued]

7. Using a trim stick or equivalent, release the B-pillar airbag applique then remove the screw that secures the upper trim panel (Figure 5).

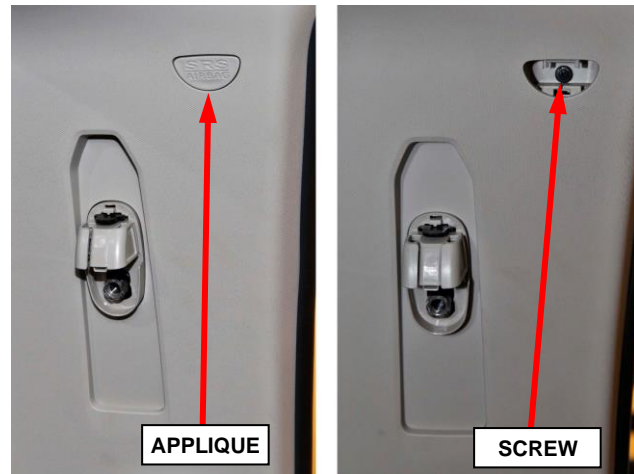

Figure 5 – B-Pillar Upper Trim Panel Fastener

8. Release the retaining clips and remove the B-pillar upper trim panel (1) (Figure 6).

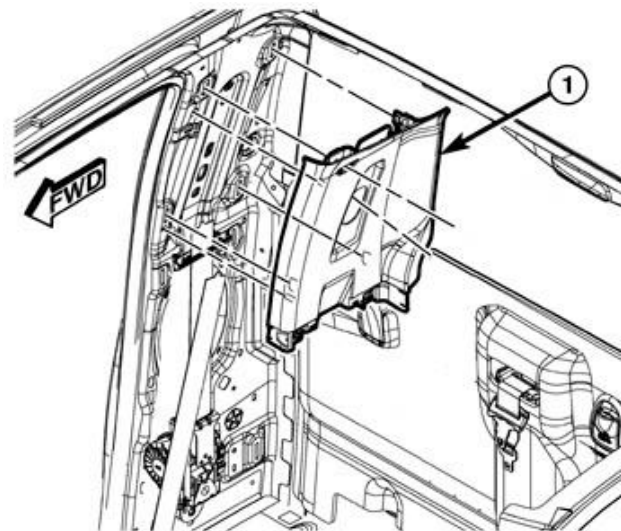

Figure 6 – B-Pillar Upper Trim Panel

9. Recline seat backs rearward to allow for room to lower the headliner.

Service Procedure [Continued]

10. Disconnect and isolate the negative battery cable. If equipped with an Intelligent Battery Sensor (IBS), disconnect the IBS connector first before disconnecting the negative battery cable. Wait two minutes for the system capacitor to discharge before further service.

WARNING: To avoid serious or fatal injury on vehicles equipped with airbags, disable the Supplemental Restraint System (SRS) before attempting any steering wheel, steering column, airbag, seat belt tensioner, impact sensor or instrument panel component diagnosis or service. Disconnect and isolate the battery negative (ground) cable, then wait two minutes for the system capacitor to discharge before performing further diagnosis or service. This is the only sure way to disable the SRS. Failure to take the proper precautions could result in accidental airbag deployment.

WARNING: To avoid serious or fatal injury when removing a deployed airbag, rubber gloves, eye protection, and a long-sleeved shirt should be worn. There may be deposits on the airbag unit and other interior surfaces. In large doses, these deposits may cause irritation to the skin and eyes.

WARNING: To avoid serious or fatal injury, use extreme care to prevent any foreign material from entering the side curtain airbag, or becoming entrapped between the side curtain airbag cushion and the headliner. Failure to observe this warning could result in occupant injuries upon airbag deployment.

NOTE: The following procedure is for replacement of an ineffective or damaged side curtain airbag (also known as Side Air Bag Inflatable Curtain/SABIC). If the airbag is ineffective or damaged, but not deployed, review local ordinances regarding recommended procedures for handling and disposal of Non-Deployed Supplemental Restraints.

NOTE: If a side curtain airbag is being removed, but has not been deployed, the headliner does not need to be removed from the passenger compartment. Lowering the headliner and resting it on the seat backs will allow enough clearance to remove the side curtain airbag from the vehicle.

Service Procedure [Continued]

CAUTION: Hands should be clean or clean cloth gloves used when handling the visors and headliner to avoid marks or damage.

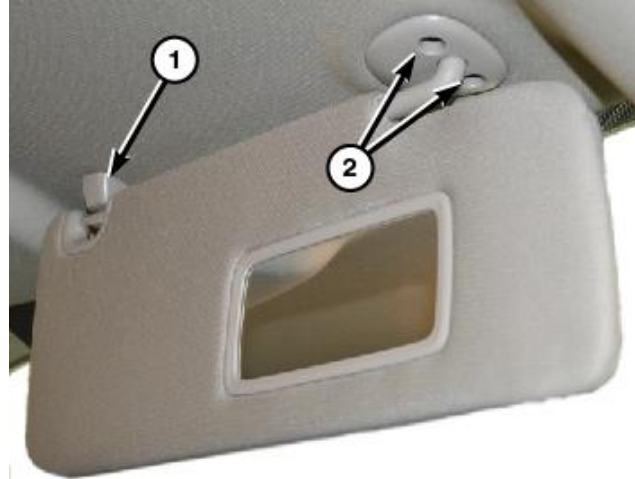

Figure 7 – Visors

11. Separate the visor from the support (1) then remove the screw and remove the visor support (Figure 7).

12. Remove the visor screws (2) then remove the visor (Figure 7).

Using a small flat bladed tool or equivalent, release the retaining tabs (1) and separate the visor from the headliner (Figure 8).

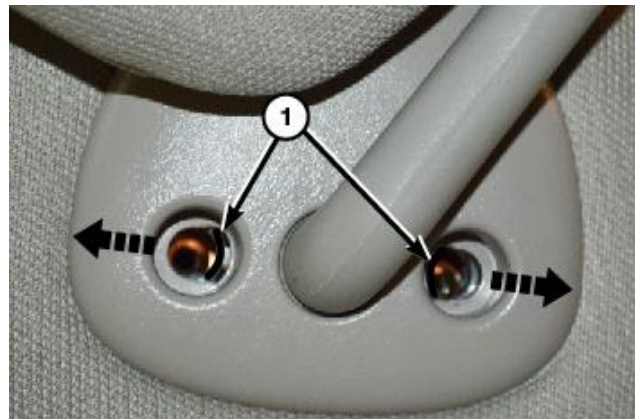

Figure 8 – Visors

13. Disconnect the visor electrical connector if equipped.

NOTE: In some cases, the wire harness for the visor vanity mirror may be glued to the top side of the headliner and may be a little difficult to release.

14. Using a small flat bladed tool, open the coat hook screw cover (2) then remove the screw and coat hook (Figure 9).

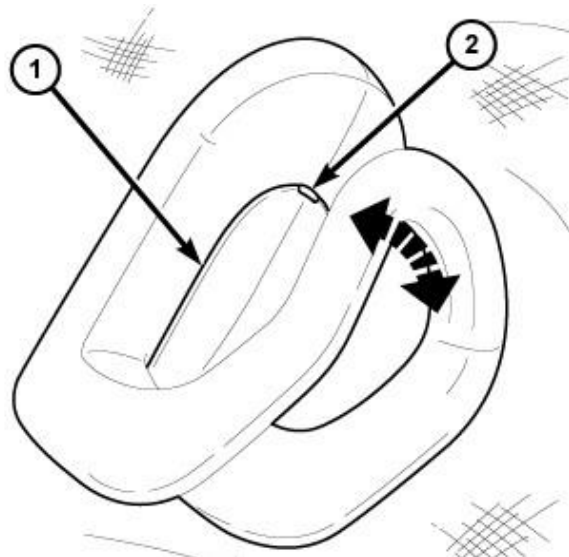

Figure 9 – Coat Hook

Service Procedure [Continued]

15. As necessary, release the headliner wiring harness clips (3) from the A-pillar to allow enough wiring harness slack for lowering the headliner (Figure 10).

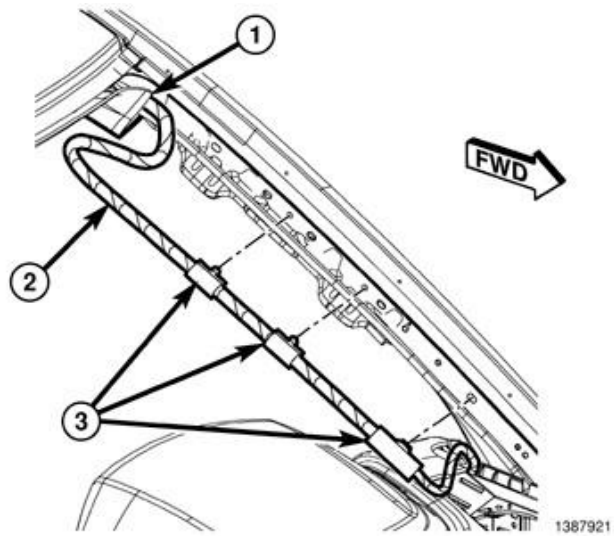

Figure 10 – Headliner Harness

16. Release the door seals from the door openings to allow for lowering of the headliner.

17. Carefully lower the headliner allowing it to rest on the seat backs and instrument panel (Figure 11).

CAUTION: Disconnect any wiring harness electrical connectors as necessary to allow enough wiring harness slack for lowering headliner. It will not be necessary to remove the headliner from the vehicle.



Figure 11 – Headliner

Service Procedure [Continued]

- 18. Locate the label on SABIC inflators. The traceability number will begin with TCL3Uxxxxxxxx for the left side or TCR3Vxxxxxxxx for the right side as shown in (Figure 12).

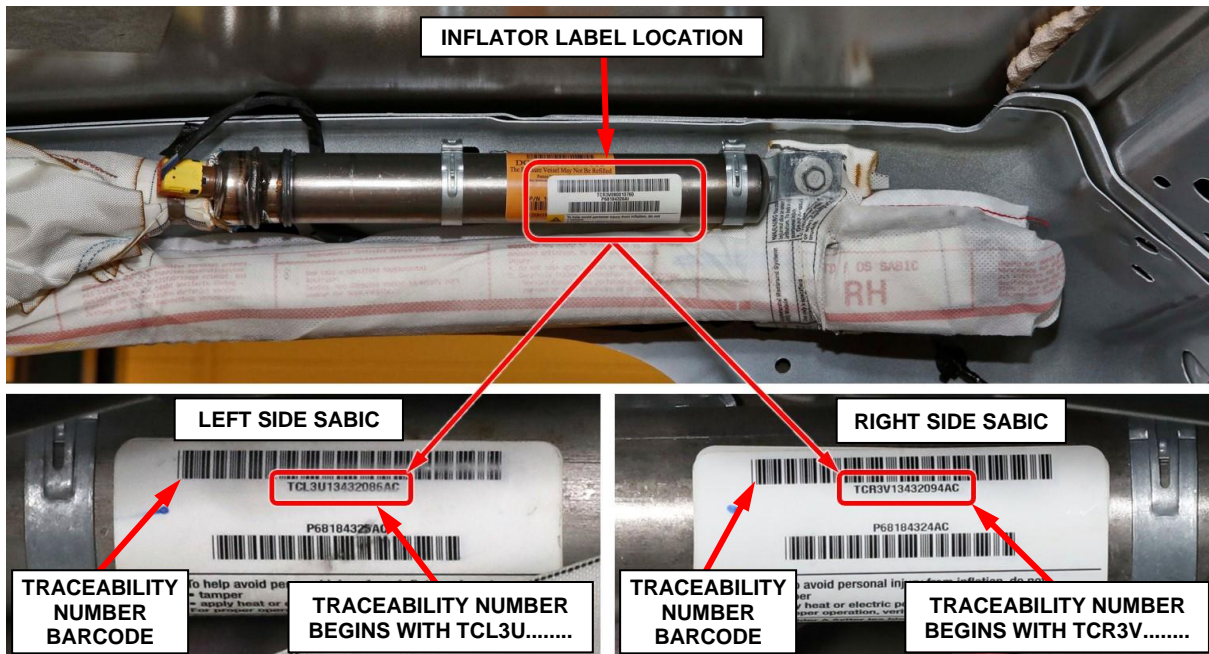



Figure 12 – SABIC Inflator Traceability Number Inspection

NOTE: A smartphone, tablet, or computer may be used for the following inspection process. Smartphone or tablet is the preferred method.

- 19. Sign into **Service Library** then enter the **Vehicle Identification Number (VIN)** and ensure you are viewing **Safety Recall Y63** service instructions. This header shown in (Figure 13) will appear above the service instructions.

Please type or scan the traceability numbers below for part verification

Left side inflator (starts with TCL3U) 

Right side inflator (starts with TCR3V) 

Figure 13 – SABIC Traceability Number Verification

Service Procedure [Continued]

20. There are **two** methods described below which may be used to inspect the right side and left side SABIC inflator traceability numbers.

NOTE: There are separate entry fields and barcode icons for right side and left side traceability numbers. Using the incorrect entry field or icon meant for the opposite side will not work.

- **Method 1:** Using a smartphone or tablet held vertically, click on the barcode scanner icon (Figure 15) to open the barcode scan function. Ensure the device camera is enabled and device is held vertically. Aim the camera directly at the SABIC traceability number barcode as shown in (Figure 14). The barcode scanner will automatically record the barcode and populate the traceability number entry field (Figure 15). Scan the barcodes for the left side and right side SABIC inflators.

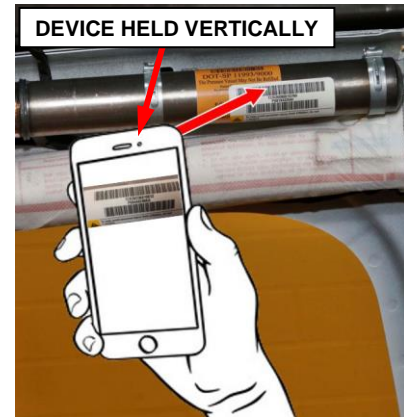

Figure 14 – Scan Barcode

- **Method 2:** Type all letters and numbers of the right side and left side SABIC inflator traceability numbers in their respective fields shown in (Figure 15).

TYPE ALL LETTERS AND NUMBERS OF THE TRACEABILITY NUMBER IN THE ENTRY FIELD

OR

CLICK THE BARCODE ICON THEN SCAN THE TRACEABILITY NUMBER BARCODE

Please type or scan the traceability numbers below for part verification

Left side inflator (starts with TCL3U)	TCL3Uxxxxxxxx		VERIFY
Right side inflator (starts with TCR3V)	TCR3Vxxxxxxxx		VERIFY

Figure 15 – Type or Scan the SABIC Traceability Number

21. Click the **VERIFY** button to the right of the traceability numbers (Figure 15).

Service Procedure [Continued]

22. Ensure both right and left SABIC traceability numbers have been checked. The traceability number verification system will return one of three possible responses for each inflator:
- *The traceability number entered is affected and the part replacement should be performed. **Suspect inflator – replace SABIC.***
 - *The traceability number entered is not affected by this recall. **Not suspect inflator – do not replace SABIC.***
 - *The traceability number entered appears to be incorrect. **Please check the number and try again.***

If verification system identified a suspect inflator affected by this recall, that SABIC must be replaced. Order the appropriate SABIC then continue with **Step 23** and replace only those SABICs that have an inflator which was identified as suspect.

If verification system identified an inflator as not suspect and not affected by this recall, that SABIC does not require replacement. Proceed to **Step 34** for any inflators which were identified as not suspect.

Service Procedure [Continued]

23. The body wire harness connector is secured by integral latches to the connector receptacle on the inflator. Pinch both latches firmly, then pull the connector straight out from the airbag inflator to disconnect it from the connector receptacle (Figure 16).
24. Remove the four bolts that secure the side curtain airbag to the inner roof rail and A-pillar (Figure 16).
25. Disengage the one plastic push-in retainer that secures the side curtain airbag tether to the inner A-pillar (Figure 16).
26. Slide the inflator rearward far enough to disengage the T-tab at the front of the inflator bracket from the keyed T-slot in the inner roof rail over the front door opening (Figure 17).
27. Remove the SABIC from the vehicle as a unit and **DISCARD** following local ordinances and recommended procedures for handling and disposal of non-deployed supplemental restraints.

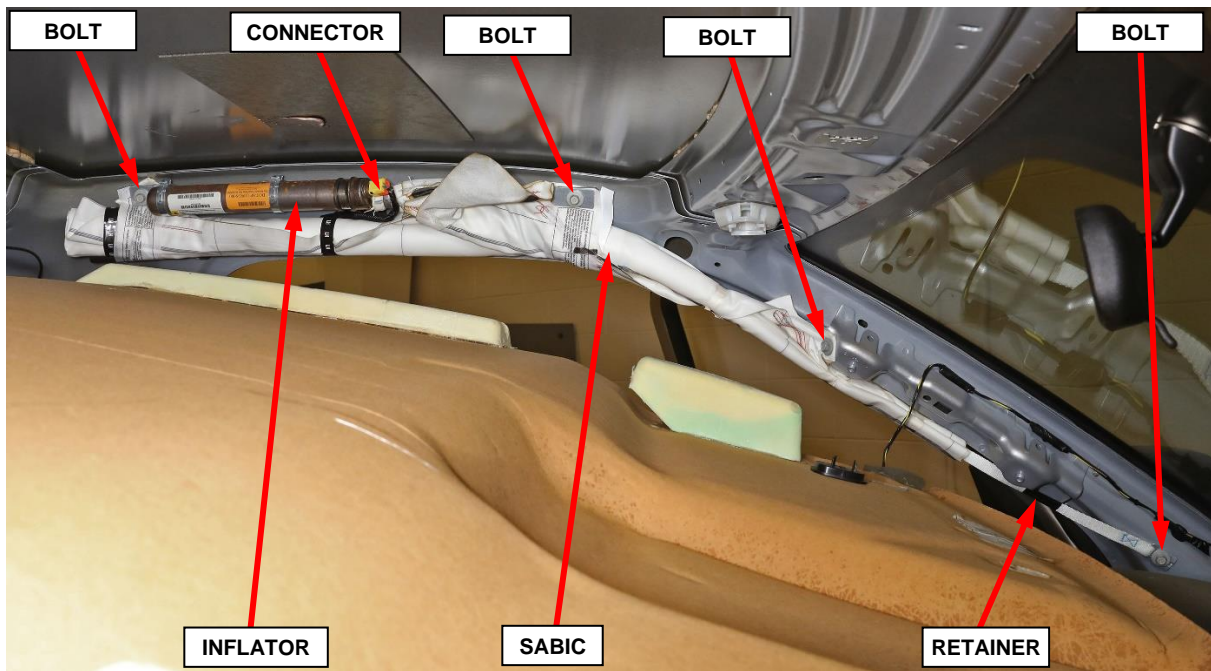
**Figure 16 – SABIC**

Service Procedure [Continued]

Figure 17 – SABIC Inflator T-Tab and Inner Roof Rail T-Slot

28. Check to be certain that the two spring nuts are properly installed in the inner roof rail and that they are in good condition.
29. Position the **NEW SABIC** into the vehicle as a unit (Figure 16).
30. Insert the T-tab at the front of the inflator bracket into the keyed T-slot in the inner roof rail over the front door opening and slide the inflator forward to engage it (Figure 17).
31. Ensure the tether is not twisted then engage the one plastic push-in retainer that secures the side curtain airbag front tether to the assist handle bracket on the inner A-pillar (Figure 16).
32. Working from rear to front, install and tighten the four bolts that secure the side curtain airbag to the inner roof rail and A-pillar. Tighten the bolts to 7 N·m (62 in. lbs.) (Figure 16).
33. Connect the body wire harness connector for the side curtain airbag to the connector receptacle of the inflator. Be certain that each connector is fully engaged in its receptacle by listening carefully for a distinct, audible click as the connector latches snap into place (Figure 16).

Service Procedure [Continued]

CAUTION: Hands should be clean or clean cloth gloves used when handling the headliner to avoid damage to the headliner.

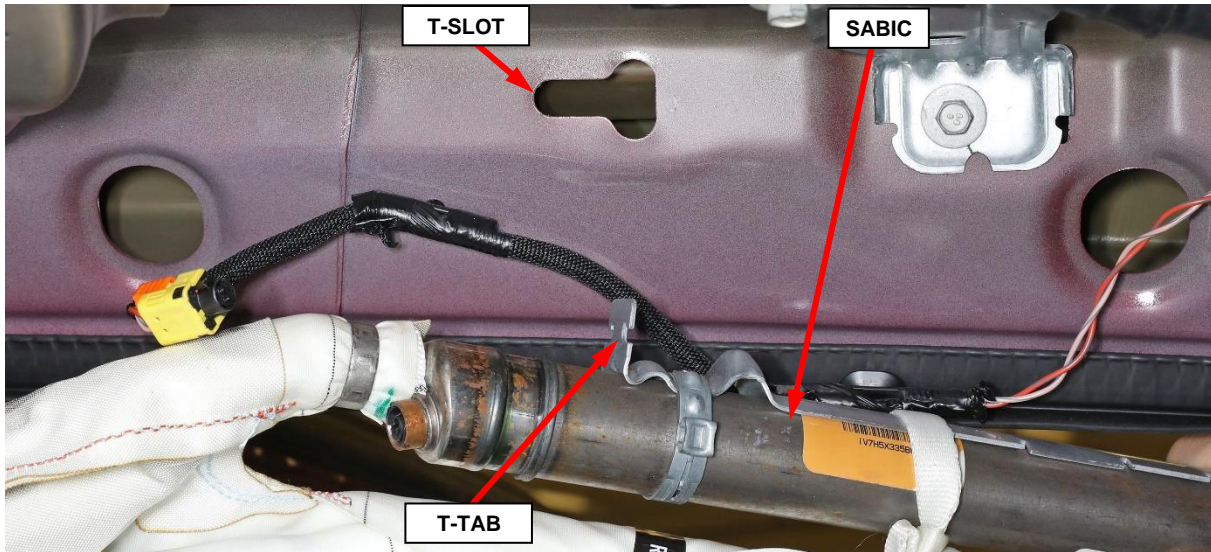
34. Raise the headliner into proper vehicle position and connect any electrical connectors previously disconnected from the headliner.

CAUTION: Be certain to avoid any wiring or drain tube interference.

35. Position the coat hooks (5) onto the headliner and install the screws tightening securely into the mounting clips then close the screw cap fully (Figure 9).
36. Position the visor supports (1) onto the headliner and install the screws into the mounting clips (Figure 7).
37. If equipped with illuminated vanity mirror, connect the wire harness connector.
38. Position the visor to the headliner and install the screws (2) that secure the visor to the roof panel. Tighten the screws to 6 N·m (53 in. lbs.) (Figure 7).
39. Reattach any headliner wiring harness clips (3) removed from the A-pillar to allow slack while lowering headliner (Figure 10).

WARNING: Do not connect the negative battery cable at this time. The Supplemental Restraint System (SRS) Verification Test procedure should be performed following service of any SRS component.

NOTE: The following procedure should be performed using a diagnostic scan tool to verify proper Supplemental Restraint System (SRS) operation following the service or replacement of any SRS component. Refer to the appropriate diagnostic procedures.

40. During the following test, the negative cable remains disconnected and isolated from the battery, as it was during the Supplemental Restraint System (SRS) component removal and installation procedures.

Service Procedure [Continued]

41. Be certain that the diagnostic scan tool contains the latest version of the proper diagnostic software. Connect the scan tool to the 16-way Data Link Connector (DLC). The DLC is located on the driver side lower edge of the instrument panel, near the steering column opening cover and outboard of the steering column.
42. Transition the status of the ignition switch (also known as the Keyless Ignition Node/KIN or IGnition Node Module/IGNM) to ON and exit the vehicle with the scan tool.
43. Check to be certain that nobody is in the vehicle, then connect the negative cable to the battery.
44. Using the scan tool, read and record the active (current) Diagnostic Trouble Code (DTC) data.
45. Next, use the scan tool to read and record any stored (historical) DTC data.
46. If any SRS related DTC is found in the previous two steps, refer to the appropriate diagnostic information.
47. Use the scan tool to erase the stored DTC data. If any problems remain, the stored DTC data will not erase. Refer to the appropriate diagnostic information to diagnose any stored DTC that will not erase. If the stored DTC information is successfully erased, continue to the next step.
48. Transition the status of the ignition switch to OFF for about 15 seconds, and then back to ON. Observe the airbag indicator in the instrument cluster. It should light from four to six seconds, and then go out. This indicates that the SRS is functioning normally and that the repairs are complete. If the airbag indicator fails to light, or lights and stays ON, there is still an active SRS fault or malfunction. Refer to the appropriate diagnostic information to diagnose the problem.
49. Raise the seat backs and position the seats forward.
50. Install the B-pillar upper trim panel (1) and engage the retaining clips fully (Figure 6).

Service Procedure [Continued]

51. Install and tighten the screw that secures the B-pillar upper trim panel then install the airbag applique cover (Figure 5).
52. Remove and **DISCARD** the bolt retainer and the bolt from the seat belt turning loop, save the spacer washer for reuse (Figure 18).
53. Using a **NEW** bolt and reusing the spacer washer, install the turning loop then tighten the bolt to 40 N·m (30 ft. lbs.) (Figure 4).
54. Install the turning loop cover (Figure 4).
55. Position the B-pillar lower trim panel and engage the retaining clips fully (Figure 3).

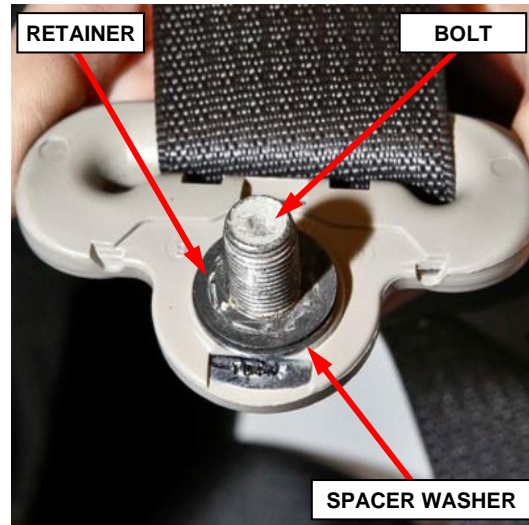
**Figure 18 – Headliner**

NOTE: Ensure that all B-pillar fasteners are installed/engaged properly.

56. Install the front seat headrests (Figure 2).
57. Position the locating tab of the A-pillar trim panel (2) into the slot located in the top of the instrument panel (Figure 1).
58. Install the A-pillar trim panel onto the A-pillar (1) and install the two bolts (4). Tighten the bolts to 5 N·m (44 in. lbs.) (Figure 1).
59. Close the two fastener covers (3) located in the A-pillar trim panel (Figure 1).
60. Install the door seals around the door openings.
61. Return the vehicle to the customer or inventory.

Service Procedure [Continued]

B. Quad Cab

1. Using a small flat-bladed tool, carefully open the two fastener covers (3) located in the A-pillar trim panel (2) (Figure 19).

2. Remove the two bolts (4) that secure the A-pillar trim panel to the A-pillar (1) and remove the trim panel (Figure 19).

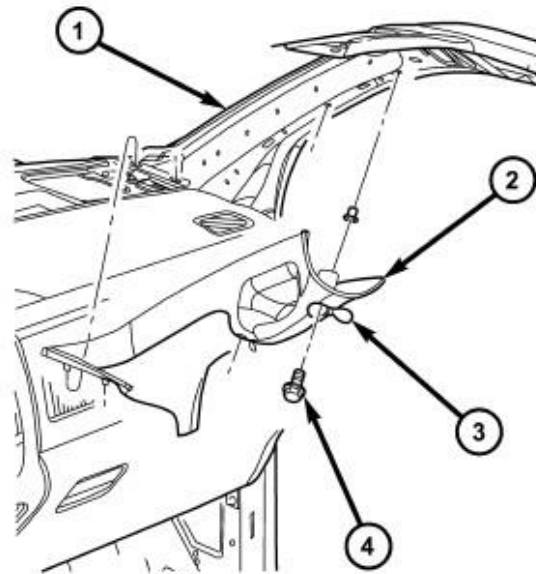

80d407a9

Figure 19 – A-Pillar

3. Push in the buttons on front seat headrest sleeves then pull the headrest up and remove (Figure 20).

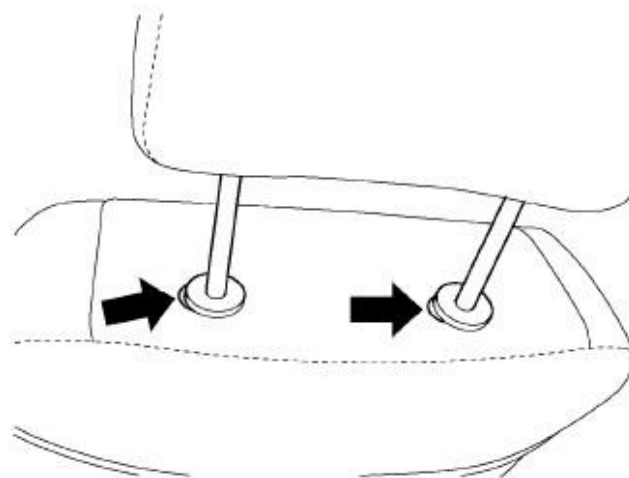

8120dd43

Figure 20 – Head Rest

4. Position the front seats to the full forward position with the seat backs fully forward.

Service Procedure [Continued]

5. Disconnect and isolate the negative battery cable. If equipped with an Intelligent Battery Sensor (IBS), disconnect the IBS connector first before disconnecting the negative battery cable. Wait two minutes for the system capacitor to discharge before further service.

WARNING: To avoid serious or fatal injury on vehicles equipped with airbags, disable the Supplemental Restraint System (SRS) before attempting any steering wheel, steering column, airbag, seat belt tensioner, impact sensor or instrument panel component diagnosis or service. Disconnect and isolate the battery negative (ground) cable, then wait two minutes for the system capacitor to discharge before performing further diagnosis or service. This is the only sure way to disable the SRS. Failure to take the proper precautions could result in accidental airbag deployment.

WARNING: To avoid serious or fatal injury when removing a deployed airbag, rubber gloves, eye protection, and a long-sleeved shirt should be worn. There may be deposits on the airbag unit and other interior surfaces. In large doses, these deposits may cause irritation to the skin and eyes.

WARNING: To avoid serious or fatal injury, use extreme care to prevent any foreign material from entering the side curtain airbag, or becoming entrapped between the side curtain airbag cushion and the headliner. Failure to observe this warning could result in occupant injuries upon airbag deployment.

NOTE: The following procedure is for replacement of an ineffective or damaged side curtain airbag (also known as Side Air Bag Inflatable Curtain/SABIC). If the airbag is ineffective or damaged, but not deployed, review local ordinances regarding recommended procedures for handling and disposal of Non-Deployed Supplemental Restraints.

NOTE: If a side curtain airbag is being removed, but has not been deployed, the headliner does not need to be removed from the passenger compartment. Lowering the headliner and resting it on the seat backs will allow enough clearance to remove the side curtain airbag from the vehicle.

Service Procedure [Continued]

6. Release the front and rear door sill scuff plates on either side of the B-pillar lower trim panel to allow for removal of the B-pillar lower trim panel (Figure 21).



Front Door Sill



Rear Door Sill

Figure 21 – Door Sill Scuff Plates

7. Release the retaining clips and remove the B-pillar lower trim panel to allow for removal of the B-pillar upper trim panel (Figure 22).

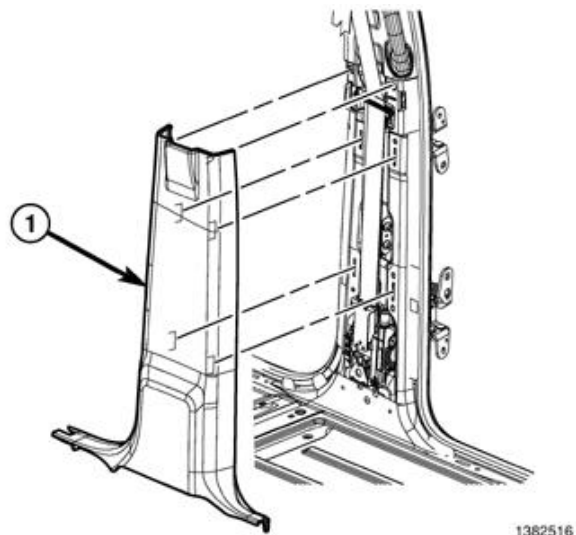

Figure 22 – B-Pillar Lower Trim Panel

Service Procedure [Continued]

- On the B-pillar, separate the seatbelt turning loop cover then remove the turning loop bolt (Figure 23).

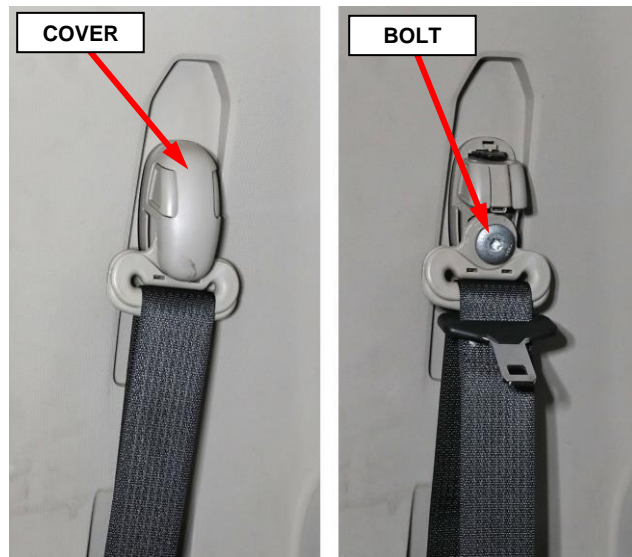

Figure 23 – Seat Belt Turning Loop

- On the B-pillar, use a small flat-bladed tool to carefully open the two fastener covers (2) located on the grab handle (Figure 24).

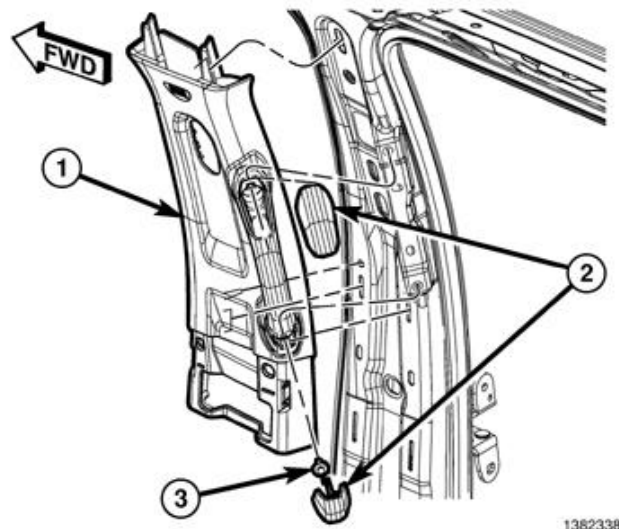

Figure 24 – B-Pillar Upper Trim Panel

- Using a trim stick C-4755 or equivalent, release the retaining clips that secure the B-pillar upper trim panel (1) then position the trim panel out of the way. It is not necessary to remove the seat belt from the trim panel (Figure 24).

Service Procedure [Continued]

12. Using a small flat bladed tool, open the coat hook screw cover (2) then remove the screw and coat hook (Figure 25).

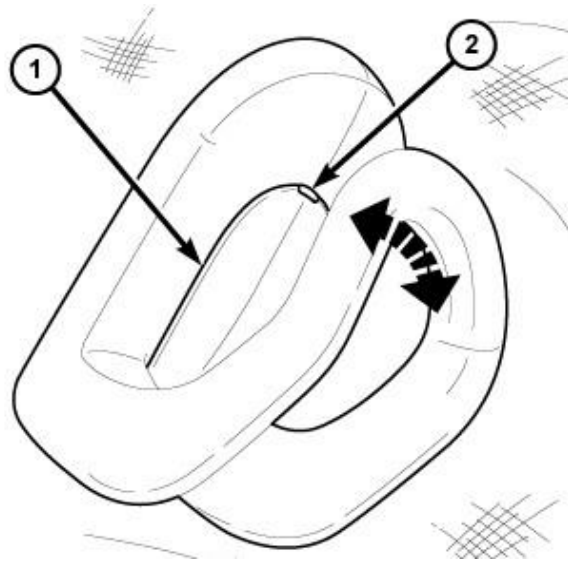

Figure 25 – Coat Hook

13. On the C-pillar, lift the seat belt turning loop cover then remove the turning loop bolt (Figure 26).

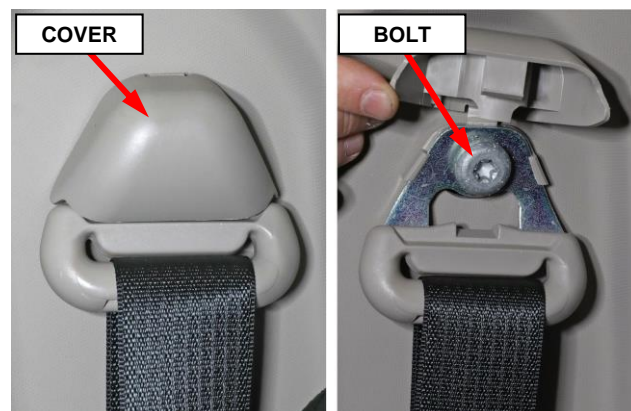

Figure 26 – Seat Belt Turning Loop

Service Procedure [Continued]

NOTE: Do not drop the screw inside the C-pillar, a magnetic screw driver may be helpful.

14. Using a trim stick or equivalent, release the C-pillar airbag applique then remove the screw that secures the upper trim panel (Figure 27).

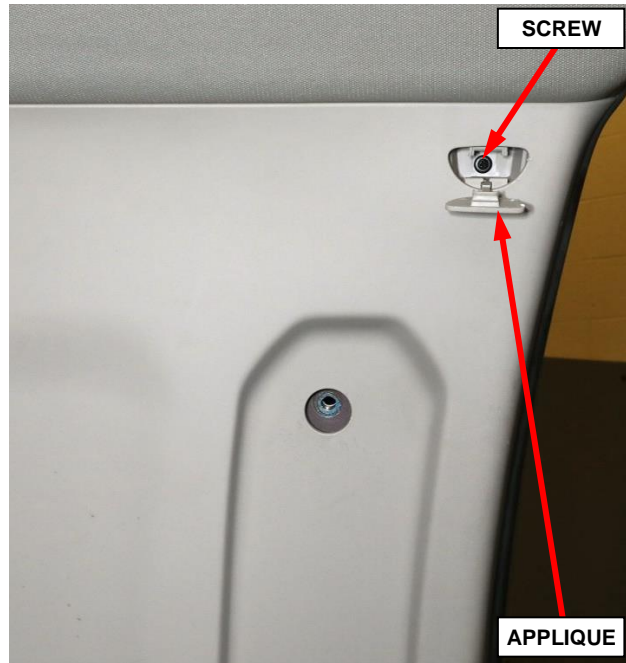

Figure 27 – C-Pillar Upper Trim Panel

15. Release the retaining clips and tilt the top of the C-pillar upper trim panel inward (Figure 28).



Figure 28 – C-Pillar Upper Trim Panel

Service Procedure [Continued]

CAUTION: Hands should be clean or clean cloth gloves used when handling the visors and headliner to avoid marks or damage.

16. If equipped with DVD monitor, remove the screws (2) and separate the monitor (1) from the roof (Figure 29).

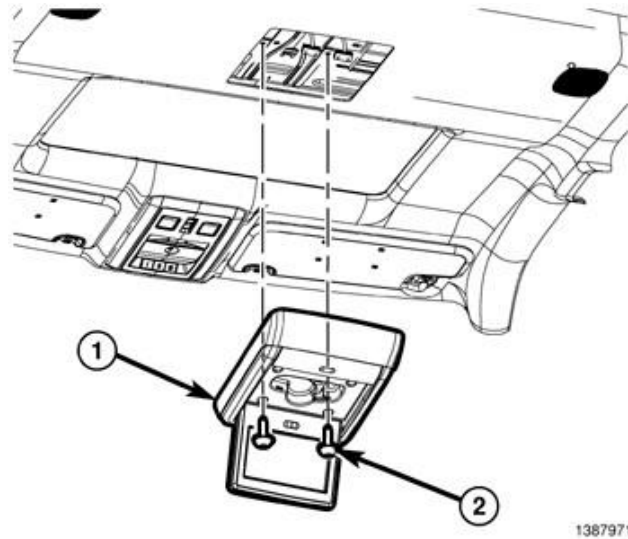

Figure 29 – Rear Seat DVD Monitor

17. If equipped with DVD monitor, disconnect the electrical connectors (1) (Figure 30).

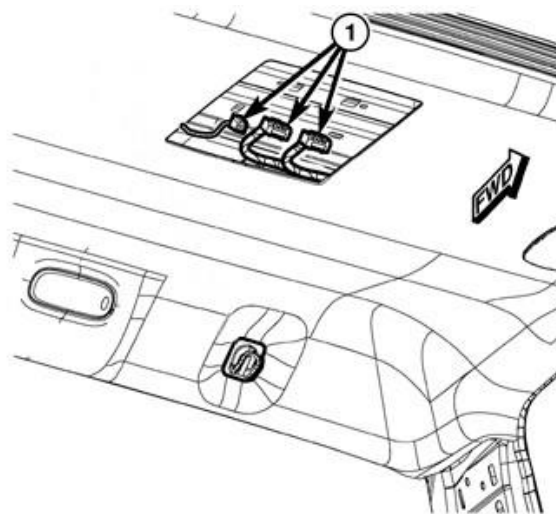

Figure 30 – DVD Monitor Electrical Connectors

Service Procedure [Continued]

18. Separate the visor from the support (1) then remove the screw and remove the visor support (Figure 31).

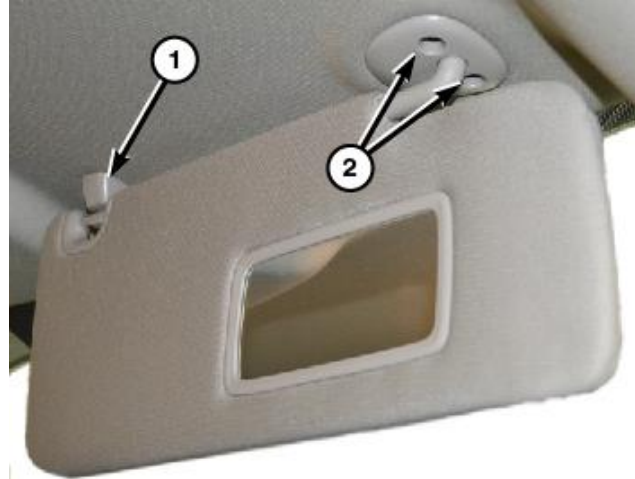

Figure 31 – Visors

19. Remove the visor screws (2) then remove the visor (Figure 31).

Using a small flat bladed tool or equivalent, release the retaining tabs (1) and separate the visor from the headliner (Figure 32).

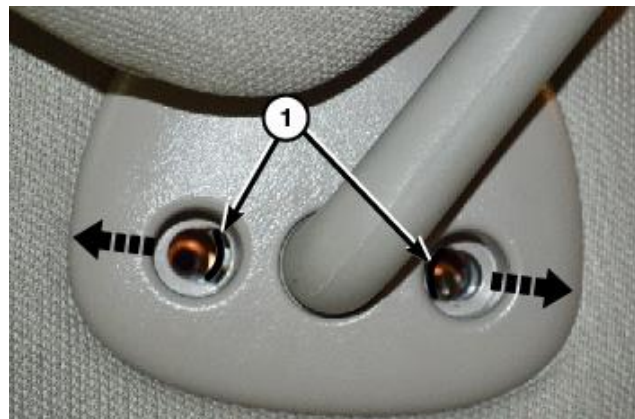

Figure 32 – Visors

20. Disconnect the visor electrical connector if equipped.

NOTE: In some cases, the wire harness for the visor vanity mirror may be glued to the top side of the headliner and may be a little difficult to release.

21. As necessary, release the headliner wiring harness clips (3) from the A-pillar to allow enough wiring harness slack for lowering the headliner (Figure 33).

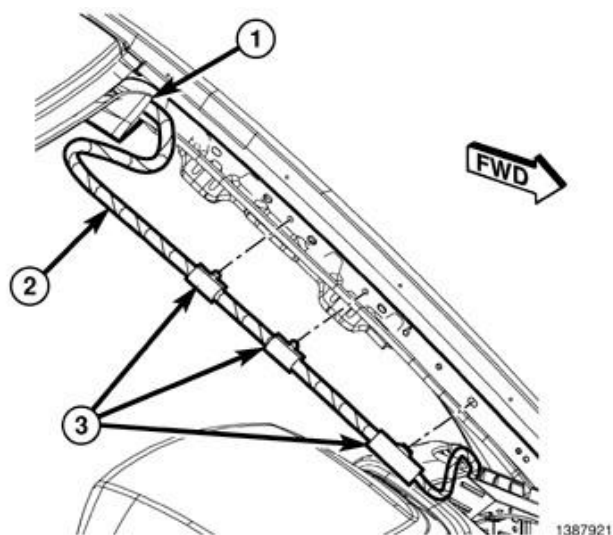

Figure 33 – Headliner Harness

Service Procedure [Continued]

22. Release the door seals from the door openings to allow for lowering of the headliner.
23. Tilt the rear view mirror up to allow clearance for lowering the headliner (Figure 34).
24. Carefully tilt the front of the headliner (2) down to clear the rear view mirror then slide the headliner forward to clear the C-pillar trim while disconnecting any wiring harness electrical connectors (1) as necessary to allow enough wiring harness slack to lower the headliner (Figure 35).

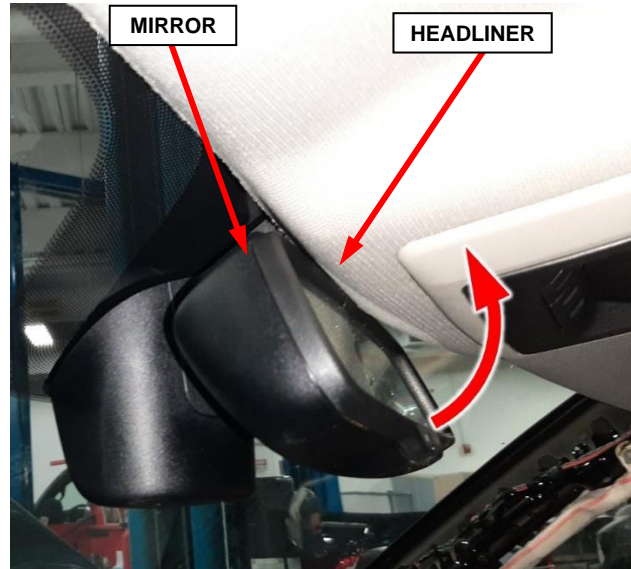

Figure 34 – Headliner Harness

25. Lower the headliner (2) allowing it to rest on the seat backs and instrument panel (Figure 35).

NOTE: It will not be necessary to remove the headliner from the vehicle.

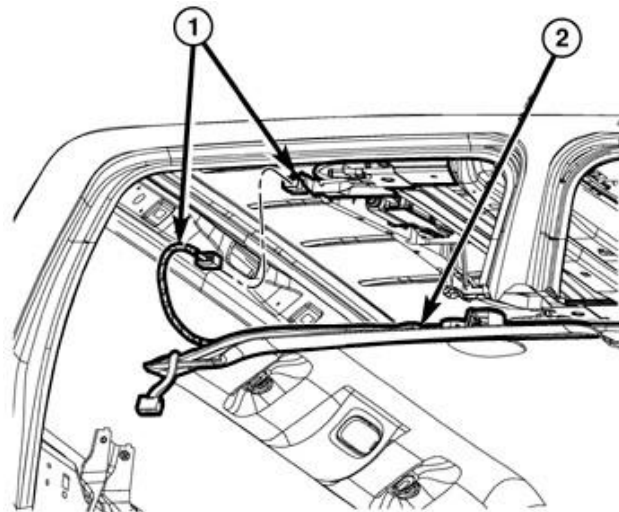

Figure 35 – Headliner Harness

Service Procedure [Continued]

- 26. Locate the label on SABIC inflators. The traceability number will begin with TCL3Uxxxxxxxx for the left side or TCR3Vxxxxxxxx for the right side as shown in (Figure 36).

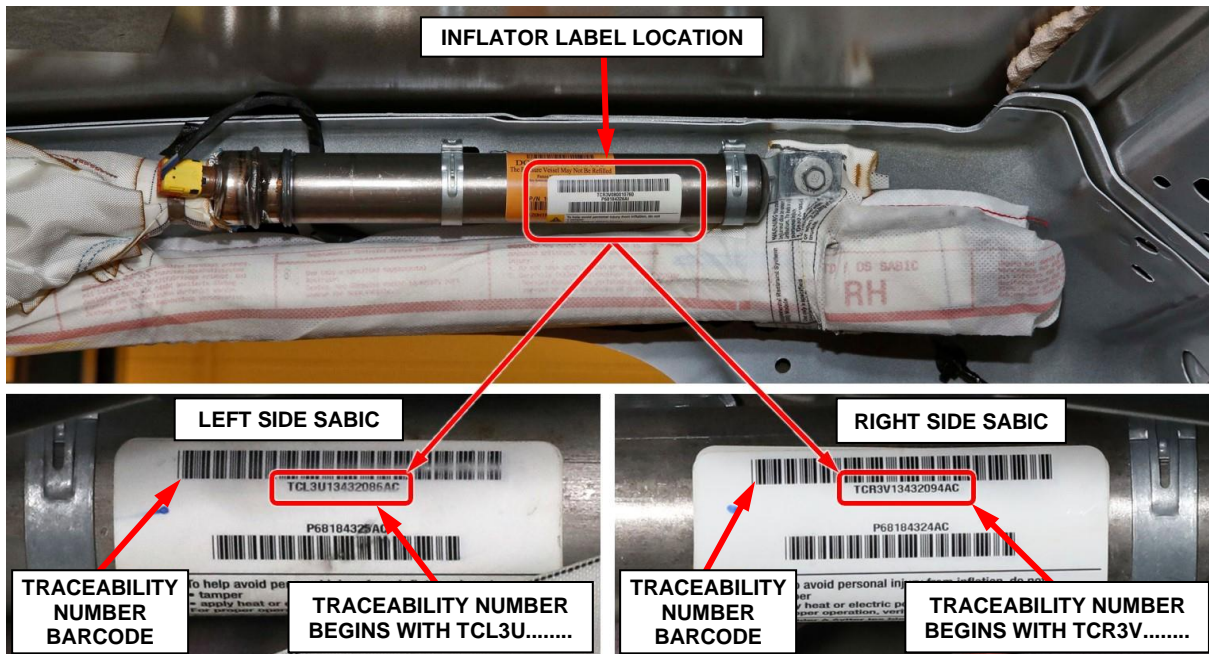



Figure 36 – SABIC Inflator Traceability Number Inspection

NOTE: A smartphone, tablet, or computer may be used for the following inspection process. Smartphone or tablet is the preferred method.

- 27. Sign into **Service Library** then enter the **Vehicle Identification Number (VIN)** and ensure you are viewing **Safety Recall Y63** service instructions. This header shown in (Figure 37) will appear above the service instructions.

Please type or scan the traceability numbers below for part verification

Left side inflator (starts with TCL3U) 

Right side inflator (starts with TCR3V) 

Figure 37 – SABIC Traceability Number Verification

Service Procedure [Continued]

28. There are **two** methods described below which may be used to inspect the right side and left side SABIC inflator traceability numbers.

NOTE: There are separate entry fields and barcode icons for right side and left side traceability numbers. Using the incorrect entry field or icon meant for the opposite side will not work.

- **Method 1:** Using a smartphone or tablet held vertically, click on the barcode scanner icon (Figure 39) to open the barcode scan function. Ensure the device camera is enabled and device is held vertically. Aim the camera directly at the SABIC traceability number barcode as shown in (Figure 38). The barcode scanner will automatically record the barcode and populate the traceability number entry field (Figure 39). Scan the barcodes for the left side and right side SABIC inflators.

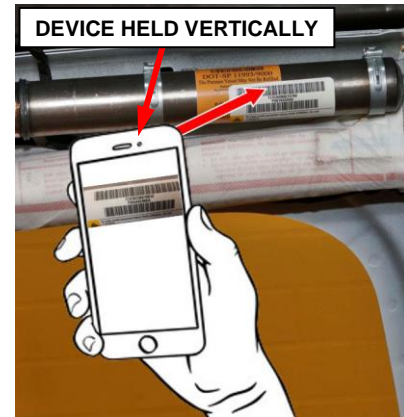

Figure 38 – Scan Barcode

- **Method 2:** Type all letters and numbers of the right side and left side SABIC inflator traceability numbers in their respective fields shown in (Figure 39).

TYPE ALL LETTERS AND NUMBERS OF THE TRACEABILITY NUMBER IN THE ENTRY FIELD

OR

CLICK THE BARCODE ICON THEN SCAN THE TRACEABILITY NUMBER BARCODE

Please type or scan the traceability numbers below for part verification

Left side inflator (starts with TCL3U)	TCL3Uxxxxxxxxx		<input type="button" value="VERIFY"/>
Right side inflator (starts with TCR3V)	TCR3Vxxxxxxxxx		<input type="button" value="VERIFY"/>

Figure 39 – Type or Scan the SABIC Traceability Number

29. Click the **VERIFY** button to the right of the traceability numbers (Figure 39).

Service Procedure [Continued]

30. Ensure both right and left SABIC traceability numbers have been checked. The traceability number verification system will return one of three possible responses for each inflator:
- *The traceability number entered is affected and the part replacement should be performed. **Suspect inflator – replace SABIC.***
 - *The traceability number entered is not affected by this recall. **Not suspect inflator – do not replace SABIC.***
 - *The traceability number entered appears to be incorrect. **Please check the number and try again.***

If verification system identified a suspect inflator affected by this recall, that SABIC must be replaced. Order the appropriate SABIC then continue with **Step 31** and replace only those SABICs that have an inflator which was identified as suspect.

If verification system identified an inflator as not suspect and not affected by this recall, that SABIC does not require replacement. Proceed to **Step 42** for any inflators which were identified as not suspect.

Service Procedure [Continued]

31. The body wire harness connector (5) is secured by integral latches to the connector receptacle on the inflator (4). Pinch both latches firmly, then pull the connector straight out from the airbag inflator to disconnect it from the connector receptacle (Figure 40).
32. Remove the six bolts (8) that secure the side curtain airbag (6) to the inner roof rail and A-pillar (Figure 40).
33. Disengage the plastic push-in retainer (9) that secures the side curtain airbag tether to the inner A-pillar (1) and the plastic push-in retainer (7) that secures the side curtain airbag to the inner roof rail (Figure 40).
34. Slide the inflator rearward far enough to disengage the T-tab at the front of the inflator bracket from the keyed T-slot in the inner roof rail over the rear door opening (Figure 41).
35. Remove the SABIC (6) from the vehicle as a unit and **DISCARD** following local ordinances and recommended procedures for handling and disposal of Non-Deployed Supplemental Restraints (Figure 40).

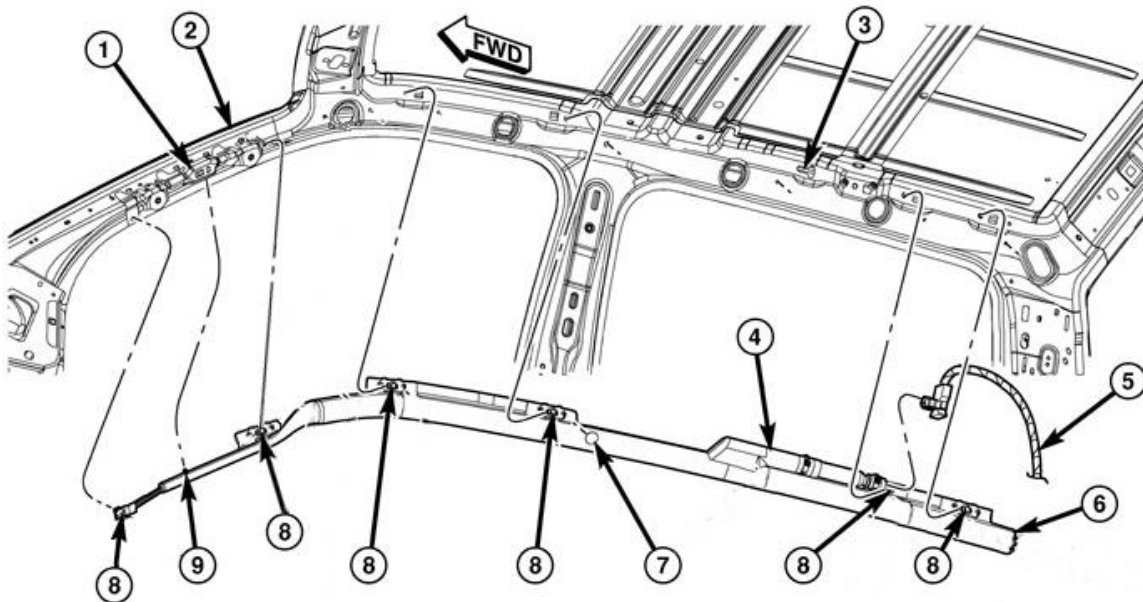
**Figure 40 – SABIC**

Service Procedure [Continued]

Figure 41 – SABIC Inflator T-Tab and Inner Roof Rail T-Slot

36. Check to be certain that the spring nuts are properly installed in the inner roof rail and that they are in good condition.
37. Position the **NEW SABIC** (6) into the vehicle as a unit (Figure 40).
38. Insert the T-tab at the front of the inflator bracket into the keyed T-slot in the inner roof rail over the rear door opening and slide the inflator forward to engage it (Figure 41).
39. Engage the plastic push-in retainer (7) that secures the side curtain airbag to the inner roof rail and ensure the tether is not twisted then engage the plastic push-in retainer (9) that secures the side curtain airbag front tether to the assist handle bracket on the inner A-pillar (1) (Figure 40).
40. Working from rear to front, install and tighten the six bolts (8) that secure the side curtain airbag (6) to the inner roof rail and A-pillar. Tighten the bolts to 7 N·m (62 in. lbs.) (Figure 40).
41. Connect the body wire harness connector (5) for the side curtain airbag to the connector receptacle of the inflator (4). Be certain that each connector is fully engaged in its receptacle by listening carefully for a distinct, audible click as the connector latches snap into place (Figure 40).

Service Procedure [Continued]

CAUTION: Hands should be clean or clean cloth gloves used when handling the headliner to avoid damage to the headliner.

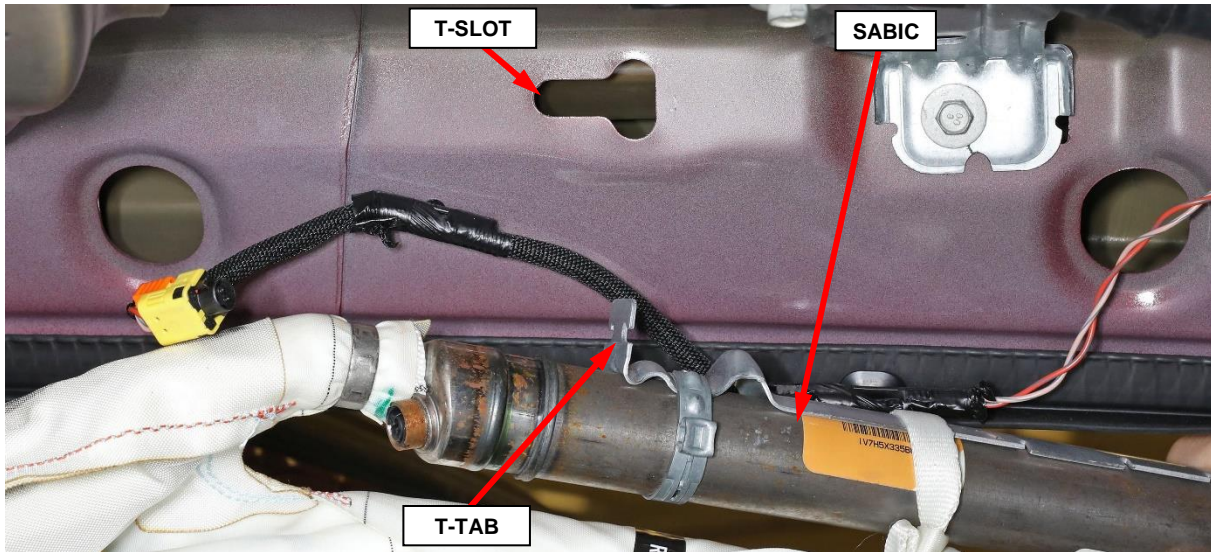
42. Raise the headliner into proper vehicle position and connect any electrical connectors previously disconnected from the headliner (Figure 35).

CAUTION: Be certain to avoid any wiring or drain tube interference.

43. Tilt the rear view mirror down to support the headliner (Figure 34).
44. Position the visor supports (1) onto the headliner and install the screws into the mounting clips (Figure 31).
45. If equipped with illuminated vanity mirror, connect the wire harness connector.
46. Position the visor to the headliner and install the screws (2) that secure the visor to the roof panel. Tighten the screws to 6 N·m (53 in. lbs.) (Figure 31).
47. Reattach any headliner wiring harness clips (3) removed from the A-pillar to allow slack while lowering headliner (Figure 33).
48. If equipped with DVD monitor, connect the DVD monitor electrical connectors (1) (Figure 30). Position the DVD monitor to the roof then install and tighten the screws (2) (Figure 29).

Service Procedure [Continued]

49. Position the upper trim to the C-pillar then engage the retaining clips (Figure 28).
50. Install and tighten the screw that secures the C-pillar upper trim panel. Then install the airbag applique (Figure 27).
51. Remove and **DISCARD** the bolt retainer and bolt from the seat belt turning loop, save the spacer washer for reuse (Figure 42).

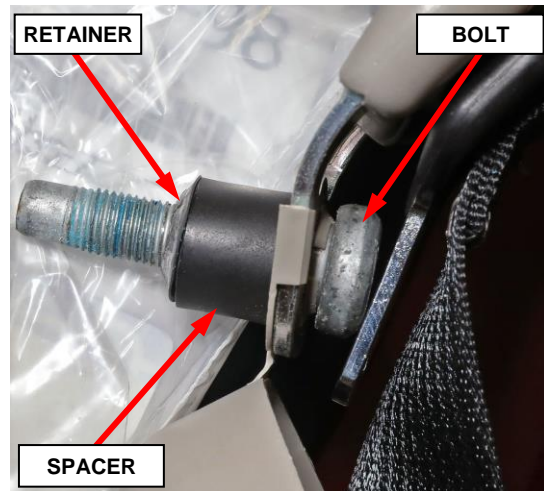
**Figure 42 – Turning Loop Bolt**

52. Using a **NEW** bolt and reusing the spacer, install the turning loop then tighten the bolt to 40 N·m (30 ft. lbs.) (Figure 26).
53. Install the seat belt turning loop cover (Figure 26).
54. Position the coat hooks (5) onto the headliner and install the screws tightening securely into the mounting clips then close the screw cap fully (Figure 25).
55. Install the B-pillar upper trim panel (1) and engage the retaining clips fully (Figure 24).
56. Install the grab handle bolts (3) and tighten to 5 N·m (44 in. lbs.). Close the fastener covers (2) (Figure 24).

Service Procedure [Continued]

57. Remove and **DISCARD** the bolt retainer and bolt from the seat belt turning loop, save the spacer washer for reuse (Figure 43).
58. Using a **NEW** bolt and reusing the spacer washer, install the turning loop then tighten the bolt to 40 N·m (30 ft. lbs.) (Figure 23).
59. Install the seat belt turning loop cover (Figure 29).

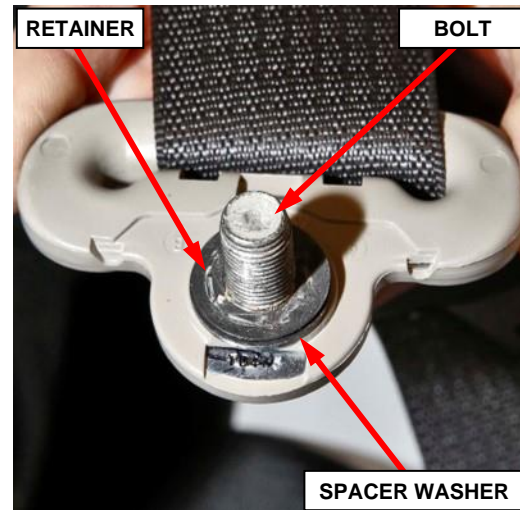
**Figure 43 – Turning Loop Bolt**

60. Position the B-pillar lower trim panel and engage the retaining clips fully (Figure 22).
61. Position the front and rear door sill scuff plates and engage the retainers (Figure 21).

Service Procedure [Continued]

WARNING: Do not connect the negative battery cable at this time. The Supplemental Restraint System (SRS) Verification Test procedure should be performed following service of any SRS component.

NOTE: The following procedure should be performed using a diagnostic scan tool to verify proper Supplemental Restraint System (SRS) operation following the service or replacement of any SRS component. Refer to the appropriate diagnostic procedures.

62. During the following test, the negative cable remains disconnected and isolated from the battery, as it was during the Supplemental Restraint System (SRS) component removal and installation procedures.
63. Be certain that the diagnostic scan tool contains the latest version of the proper diagnostic software. Connect the scan tool to the 16-way Data Link Connector (DLC). The DLC is located on the driver side lower edge of the instrument panel, near the steering column opening cover and outboard of the steering column.
64. Transition the status of the ignition switch (also known as the Keyless Ignition Node/KIN or Ignition Node Module/IGNM) to ON and exit the vehicle with the scan tool.
65. Check to be certain that nobody is in the vehicle, then connect the negative cable to the battery.

Service Procedure [Continued]

66. Using the scan tool, read and record the active (current) Diagnostic Trouble Code (DTC) data.
67. Next, use the scan tool to read and record any stored (historical) DTC data.
68. If any SRS related DTC is found in the previous two steps, refer to the appropriate diagnostic information.
69. Use the scan tool to erase the stored DTC data. If any problems remain, the stored DTC data will not erase. Refer to the appropriate diagnostic information to diagnose any stored DTC that will not erase. If the stored DTC information is successfully erased, continue to the next step.
70. Transition the status of the ignition switch to OFF for about 15 seconds, and then back to ON. Observe the airbag indicator in the instrument cluster. It should light from four to six seconds, and then go out. This indicates that the SRS is functioning normally and that the repairs are complete. If the airbag indicator fails to light, or lights and stays ON, there is still an active SRS fault or malfunction. Refer to the appropriate diagnostic information to diagnose the problem.
71. Install the front seat headrests (Figure 20).
72. Position the locating tab of the A-pillar trim panel (2) into the slot located in the top of the instrument panel (Figure 19).
73. Install the A-pillar trim panel onto the A-pillar (1) and install the two bolts (4). Tighten the bolts to 5 N·m (44 in. lbs.) (Figure 19).
74. Close the two fastener covers (3) located in the A-pillar trim panel (Figure 19).
75. Install the door seals around the door openings.
76. Return the vehicle to the customer or inventory.

Service Procedure [Continued]

C. Crew Cab

1. Using a small flat-bladed tool, carefully open the two fastener covers (3) located in the A-pillar trim panel (2) (Figure 44).

2. Remove the two bolts (4) that secure the A-pillar trim panel to the A-pillar (1) and remove the trim panel (Figure 44).

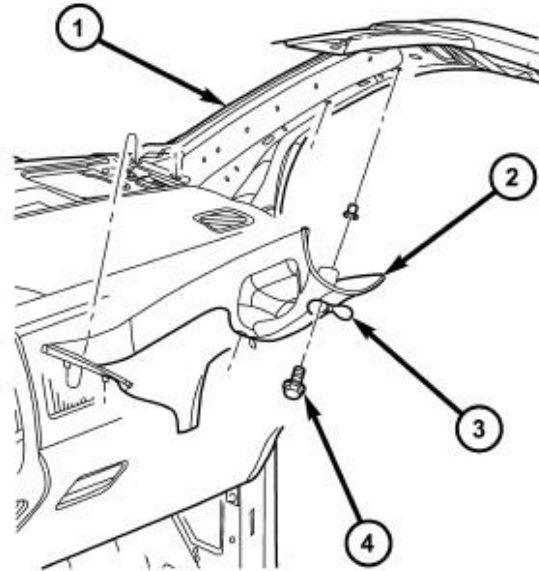

80d407a9

Figure 44 – A-Pillar

3. Push in the buttons on front seat headrest sleeves then pull the headrest up and remove (Figure 45).

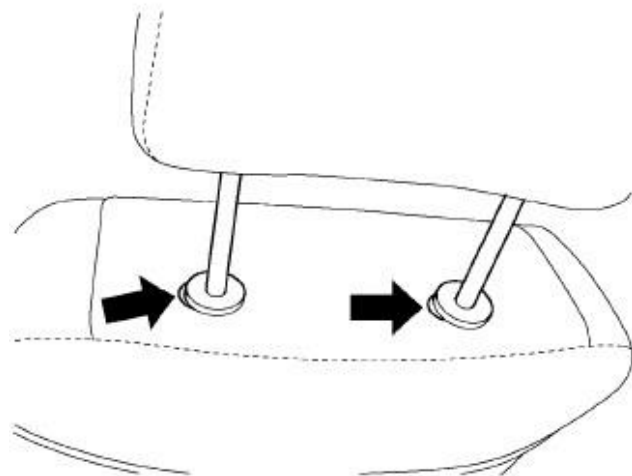

8120dd43

Figure 45 – Head Rest

4. Position the front seats to the full forward position with the seat backs fully forward.

Service Procedure [Continued]

5. Disconnect and isolate the negative battery cable. If equipped with an Intelligent Battery Sensor (IBS), disconnect the IBS connector first before disconnecting the negative battery cable. Wait two minutes for the system capacitor to discharge before further service.

WARNING: To avoid serious or fatal injury on vehicles equipped with airbags, disable the Supplemental Restraint System (SRS) before attempting any steering wheel, steering column, airbag, seat belt tensioner, impact sensor or instrument panel component diagnosis or service. Disconnect and isolate the battery negative (ground) cable, then wait two minutes for the system capacitor to discharge before performing further diagnosis or service. This is the only sure way to disable the SRS. Failure to take the proper precautions could result in accidental airbag deployment.

WARNING: To avoid serious or fatal injury when removing a deployed airbag, rubber gloves, eye protection, and a long-sleeved shirt should be worn. There may be deposits on the airbag unit and other interior surfaces. In large doses, these deposits may cause irritation to the skin and eyes.

WARNING: To avoid serious or fatal injury, use extreme care to prevent any foreign material from entering the side curtain airbag, or becoming entrapped between the side curtain airbag cushion and the headliner. Failure to observe this warning could result in occupant injuries upon airbag deployment.

NOTE: The following procedure is for replacement of an ineffective or damaged side curtain airbag (also known as Side Air Bag Inflatable Curtain/SABIC). If the airbag is ineffective or damaged, but not deployed, review local ordinances regarding recommended procedures for handling and disposal of Non-Deployed Supplemental Restraints.

NOTE: If a side curtain airbag is being removed, but has not been deployed, the headliner does not need to be removed from the passenger compartment. Lowering the headliner and resting it on the seat backs will allow enough clearance to remove the side curtain airbag from the vehicle.

Service Procedure [Continued]

6. Release the front and rear door sill scuff plates on either side of the B-pillar lower trim panel to allow for removal of the B-pillar lower trim panel (Figure 46).



Front Door Sill

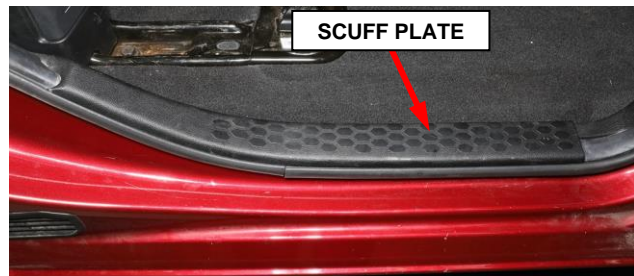

Rear Door Sill

Figure 46 – Door Sill Scuff Plates

7. Release the retaining clips and remove the B-pillar lower trim panel to allow for removal of the B-pillar upper trim panel (Figure 47).

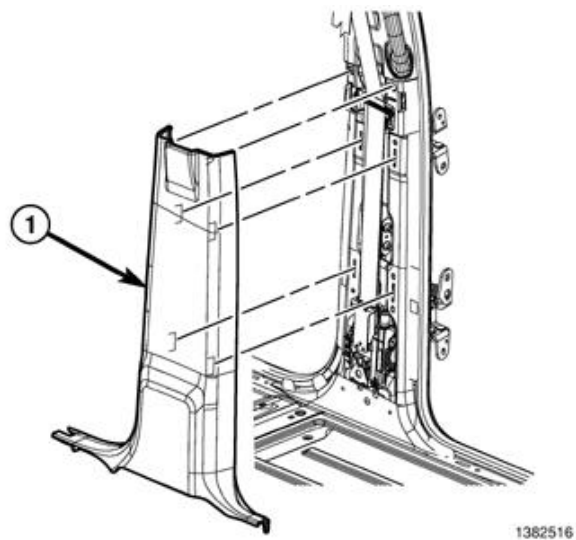

Figure 47 – B-Pillar Lower Trim Panel

Service Procedure [Continued]

8. On the B-pillar, separate the seatbelt turning loop cover then remove the turning loop bolt (Figure 48).

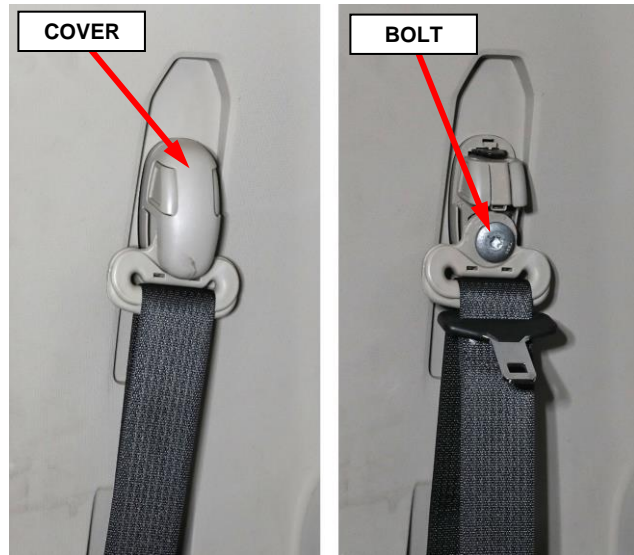

Figure 48 – Seat Belt Turning Loop

9. On the B-pillar, use a small flat-bladed tool to carefully open the two fastener covers (2) located on the grab handle (Figure 49).

10. Remove the two bolts (3) that secure the grab handle to the B-pillar (Figure 49).

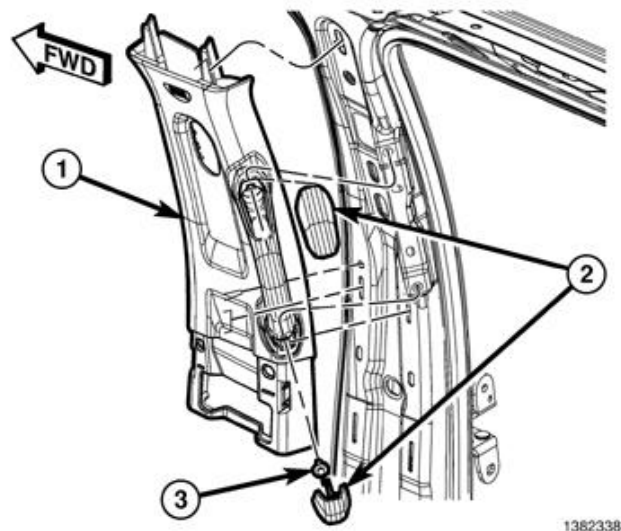

Figure 49 – B-Pillar Upper Trim Panel

11. Using a trim stick C-4755 or equivalent, release the retaining clips that secure the B-pillar upper trim panel (1) then position the trim panel out of the way. It is not necessary to remove the seat belt from the trim panel (Figure 49).

Service Procedure [Continued]

12. Using a small flat bladed tool, open the coat hook screw cover (2) then remove the screw and coat hook (Figure 50).

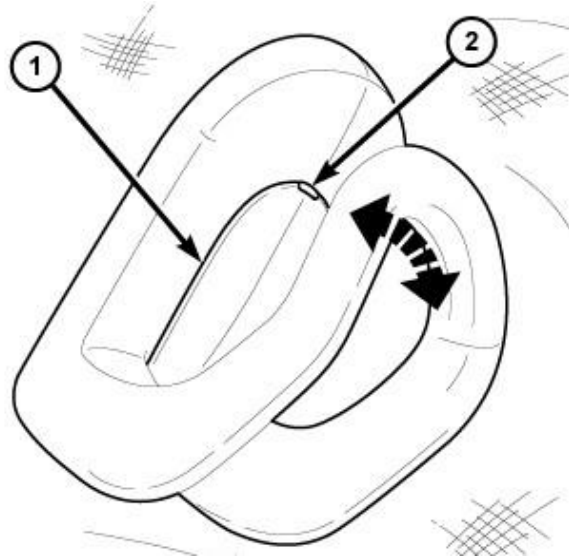

Figure 50 – Coat Hook

NOTE: Do not drop the screw inside the C-pillar, a magnetic screw driver may be helpful.

13. Using a trim stick or equivalent, release the C-pillar airbag applique then remove the screw that secures the upper trim panel (Figure 51).

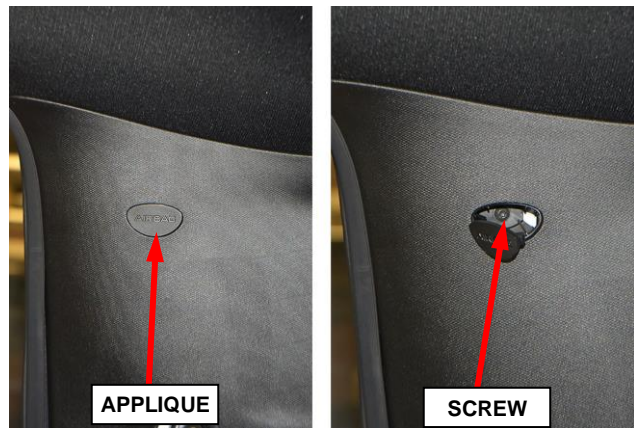

Figure 51 – C-Pillar Upper Trim Panel

14. Release the retaining clips and tilt the top of the C-pillar upper trim panel inward (Figure 52).



Figure 52 – C-Pillar Trim Panels

Service Procedure [Continued]

15. If equipped with DVD monitor, remove the screws (2) and separate the monitor (1) from the roof (Figure 64).

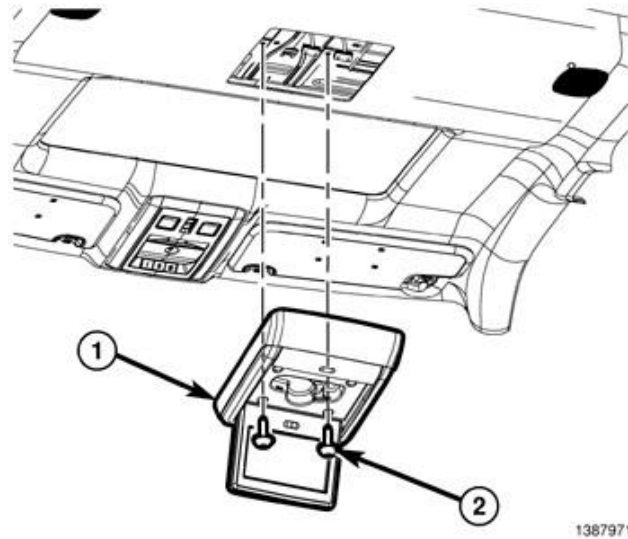

Figure 53 – Rear Seat DVD Monitor

16. If equipped with DVD monitor, disconnect the electrical connectors (1) (Figure 65).

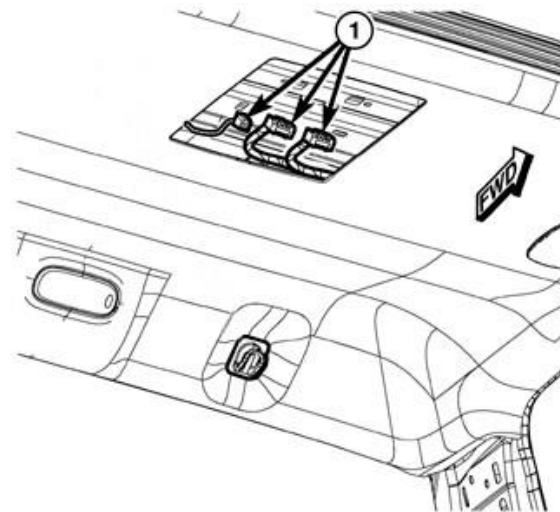

Figure 54 – DVD Monitor Electrical Connectors

Service Procedure [Continued]

17. Separate the visor from the support (1) then remove the screw and remove the visor support (Figure 55).

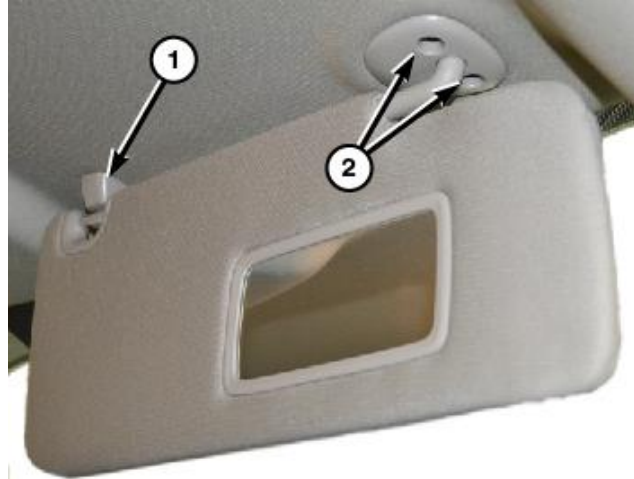

Figure 55 – Visors

18. Remove the visor screws (2) then remove the visor (Figure 55).

Using a small flat bladed tool or equivalent, release the retaining tabs (1) and separate the visor from the headliner (Figure 56).

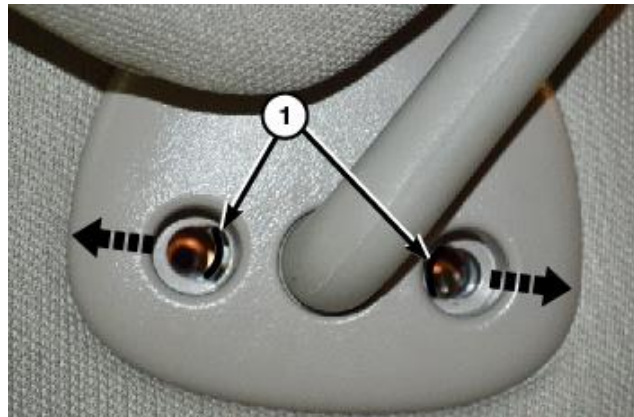

Figure 56 – Visors

19. Disconnect the visor electrical connector if equipped.

NOTE: In some cases, the wire harness for the visor vanity mirror may be glued to the top side of the headliner and may be a little difficult to release.

20. As necessary, release the headliner wiring harness clips (3) from the A-pillar to allow enough wiring harness slack for lowering the headliner (Figure 57).

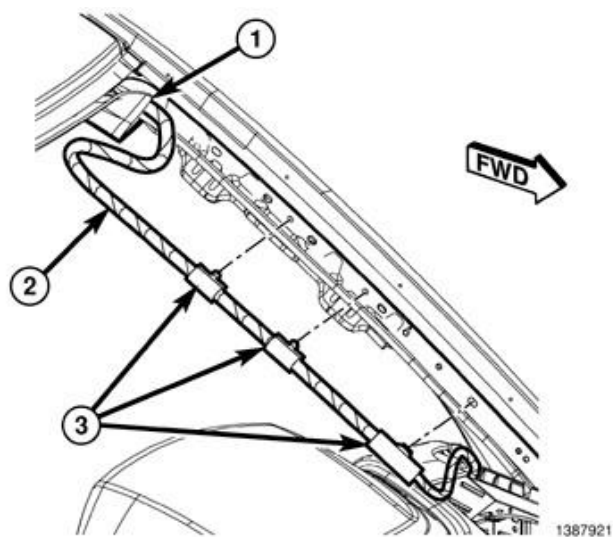

Figure 57 – Headliner Harness

Service Procedure [Continued]

21. Release the door seals from the door openings to allow for lowering of the headliner.
22. Tilt the rear view mirror up to allow clearance for lowering the headliner (Figure 58).
23. Carefully tilt the front of the headliner (2) down to clear the rear view mirror then slide the headliner forward to clear the C-pillar trim while disconnecting any wiring harness electrical connectors (1) as necessary to allow enough wiring harness slack to lower the headliner (Figure 59).

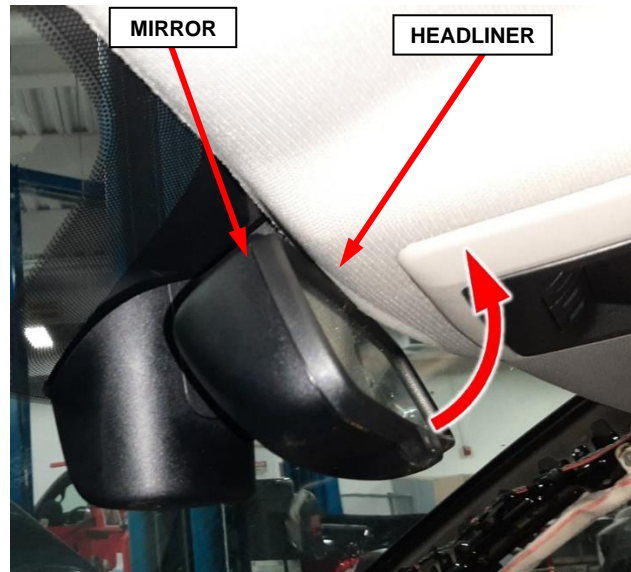

Figure 58 – Rearview Mirror

24. lower the headliner (2) allowing it to rest on the seat backs and instrument panel (Figure 59).

NOTE: It will not be necessary to remove the headliner from the vehicle.

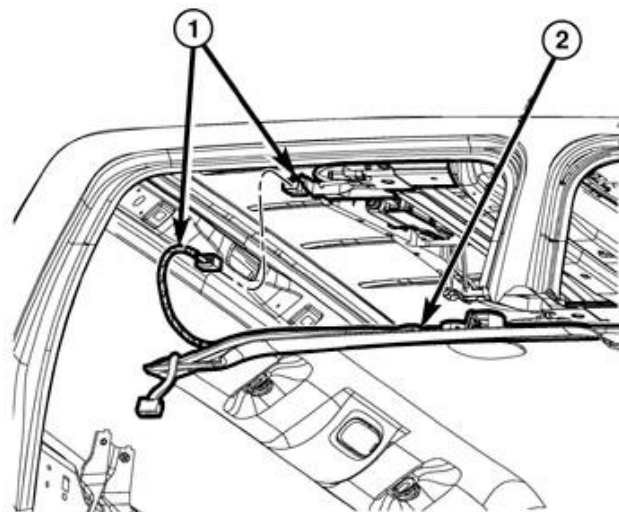

Figure 59 – Headliner Harness

Service Procedure [Continued]

- Locate the label on SABIC inflators. The traceability number will begin with TCL3Uxxxxxxxx for the left side or TCR3Vxxxxxxxx for the right side as shown in (Figure 60).

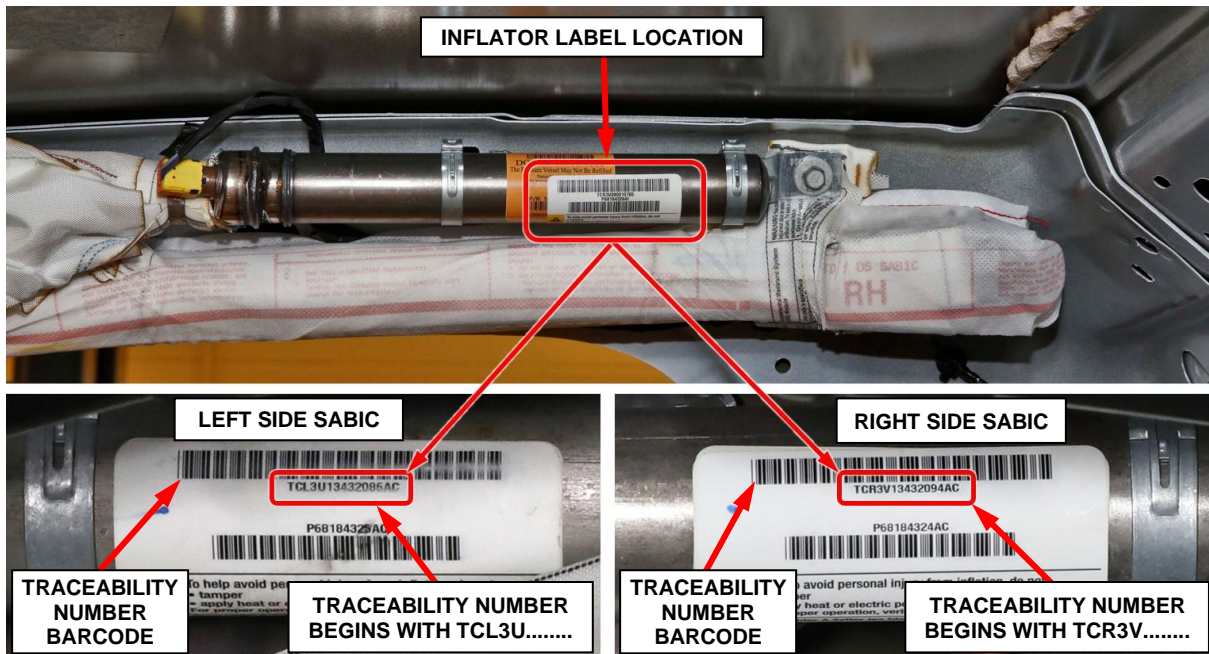



Figure 60 – SABIC Inflator Traceability Number Inspection

NOTE: A smartphone, tablet, or computer may be used for the following inspection process. Smartphone or tablet is the preferred method.

- Sign into **Service Library** then enter the **Vehicle Identification Number (VIN)** and ensure you are viewing **Safety Recall Y63** service instructions. This header shown in (Figure 61) will appear above the service instructions.

Please type or scan the traceability numbers below for part verification

Left side inflator (starts with TCL3U) 

Right side inflator (starts with TCR3V) 

Figure 61 – SABIC Traceability Number Verification

Service Procedure [Continued]

27. There are **two** methods described below which may be used to inspect the right side and left side SABIC inflator traceability numbers.

NOTE: There are separate entry fields and barcode icons for right side and left side traceability numbers. Using the incorrect entry field or icon meant for the opposite side will not work.

- **Method 1:** Using a smartphone or tablet held vertically, click on the barcode scanner icon (Figure 63) to open the barcode scan function. Ensure the device camera is enabled and device is held vertically. Aim the camera directly at the SABIC traceability number barcode as shown in (Figure 62). The barcode scanner will automatically record the barcode and populate the traceability number entry field (Figure 63). Scan the barcodes for the left side and right side SABIC inflators.



Figure 62 – Scan Barcode

- **Method 2:** Type all letters and numbers of the right side and left side SABIC inflator traceability numbers in their respective fields shown in (Figure 63).

TYPE ALL LETTERS AND NUMBERS OF THE TRACEABILITY NUMBER IN THE ENTRY FIELD

OR

CLICK THE BARCODE ICON THEN SCAN THE TRACEABILITY NUMBER BARCODE

Please type or scan the traceability numbers below for part verification

Left side inflator (starts with TCL3U)	TCL3Uxxxxxxxxx		<input type="button" value="VERIFY"/>
Right side inflator (starts with TCR3V)	TCR3Vxxxxxxxxx		<input type="button" value="VERIFY"/>

Figure 63 – Type or Scan the SABIC Traceability Number

28. Click the **VERIFY** button to the right of the traceability numbers (Figure 63).

Service Procedure [Continued]

29. Ensure both right and left SABIC traceability numbers have been checked. The traceability number verification system will return one of three possible responses for each inflator:
- *The traceability number entered is affected and the part replacement should be performed. **Suspect inflator – replace SABIC.***
 - *The traceability number entered is not affected by this recall. **Not suspect inflator – do not replace SABIC.***
 - *The traceability number entered appears to be incorrect. **Please check the number and try again.***

If verification system identified a suspect inflator affected by this recall, that SABIC must be replaced. Order the appropriate SABIC then continue with **Step 30** and replace only those SABICs that have an inflator which was identified as suspect.

If verification system identified an inflator as not suspect and not affected by this recall, that SABIC does not require replacement. Proceed to **Step 41** for any inflators which were identified as not suspect.

Service Procedure [Continued]

30. The body wire harness connector (5) is secured by integral latches to the connector receptacle on the inflator (4). Pinch both latches firmly, then pull the connector straight out from the airbag inflator to disconnect it from the connector receptacle (Figure 64).
31. Remove the six bolts (8) that secure the side curtain airbag (6) to the inner roof rail and A-pillar (Figure 64).
32. Disengage the plastic push-in retainer (9) that secures the side curtain airbag tether to the inner A-pillar (1) and the plastic push-in retainer (7) that secures the side curtain airbag to the inner roof rail (Figure 64).
33. Slide the inflator rearward far enough to disengage the T-tab at the front of the inflator bracket from the keyed T-slot in the inner roof rail over the rear door opening (Figure 65).
34. Remove the SABIC (6) from the vehicle as a unit and **DISCARD** following local ordinances and recommended procedures for handling and disposal of Non-Deployed Supplemental Restraints (Figure 64).

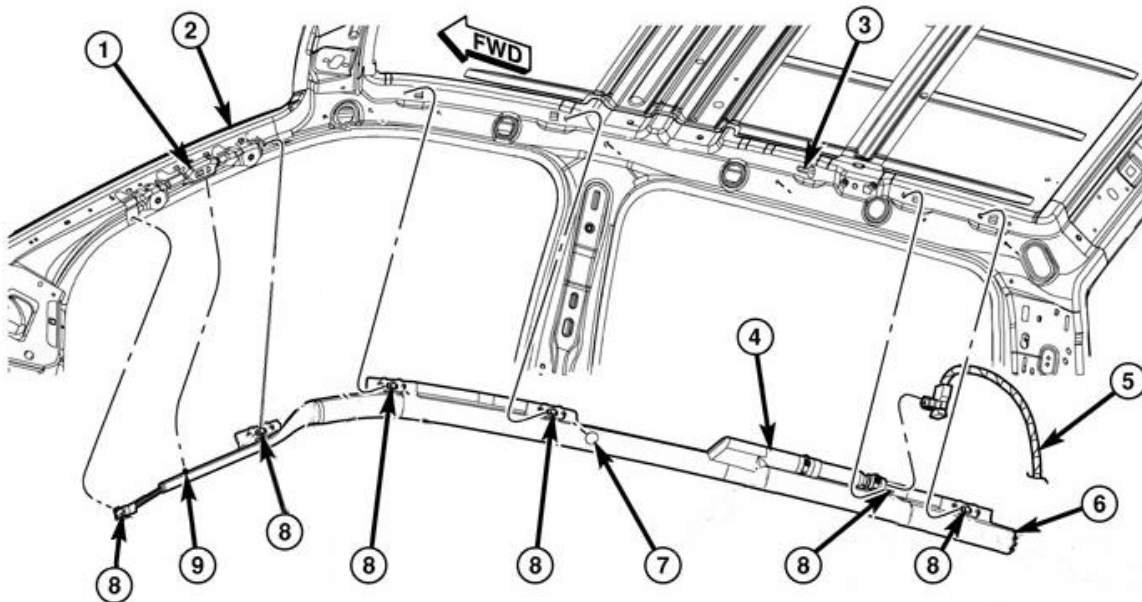
**Figure 64 – SABIC**

Service Procedure [Continued]

Figure 65 – SABIC Inflator T-Tab and Inner Roof Rail T-Slot

35. Check to be certain that the spring nuts are properly installed in the inner roof rail and that they are in good condition.
36. Position the **NEW SABIC** (6) into the vehicle as a unit (Figure 64).
37. Insert the T-tab at the front of the inflator bracket into the keyed T-slot in the inner roof rail over the rear door opening and slide the inflator forward to engage it (Figure 65).
38. Engage the plastic push-in retainer (7) that secures the side curtain airbag to the inner roof rail and ensure the tether is not twisted then engage the plastic push-in retainer (9) that secures the side curtain airbag front tether to the assist handle bracket on the inner A-pillar (1) (Figure 64).
39. Working from rear to front, install and tighten the six bolts (8) that secure the side curtain airbag (6) to the inner roof rail and A-pillar. Tighten the bolts to 7 N·m (62 in. lbs.) (Figure 64).
40. Connect the body wire harness connector (5) for the side curtain airbag to the connector receptacle of the inflator (4). Be certain that each connector is fully engaged in its receptacle by listening carefully for a distinct, audible click as the connector latches snap into place (Figure 64).

Service Procedure [Continued]

CAUTION: Hands should be clean or clean cloth gloves used when handling the headliner to avoid damage to the headliner.

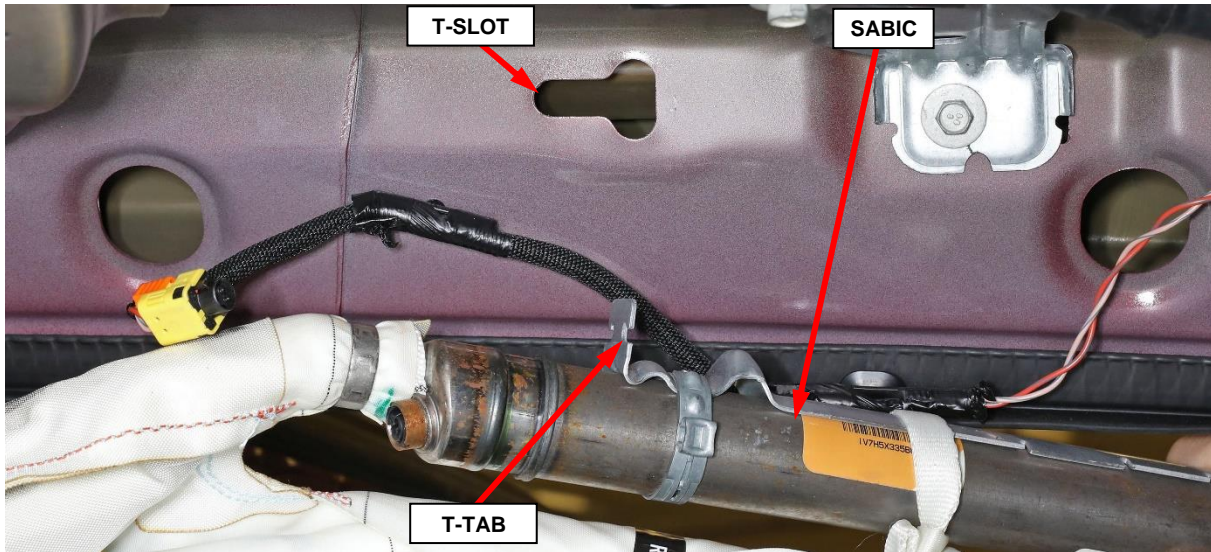
41. Raise the headliner into proper vehicle position and connect any electrical connectors previously disconnected from the headliner (Figure 59).

CAUTION: Be certain to avoid any wiring or drain tube interference.

42. Tilt the rear view mirror down to allow it to support the headliner (Figure 58).
43. Reattach any headliner wiring harness clips (3) removed from the A-pillar to allow slack while lowering headliner (Figure 57).
44. Position the visor supports (1) onto the headliner and install the screws into the mounting clips (Figure 55).
45. If equipped with illuminated vanity mirror, connect the wire harness connector.
46. Position the visor to the headliner and install the screws (2) that secure the visor to the roof panel. Tighten the screws to 6 N·m (53 in. lbs.) (Figure 55).
47. If equipped with DVD monitor, connect the DVD monitor electrical connectors (1) (Figure 54). Position the DVD monitor to the roof then install and tighten the screws (2) (Figure 53).
48. Position the upper trim panel to the C-pillar then engage the retaining clips (Figure 52).
49. Install and tighten the screw that secures the C-pillar upper trim panel. Then install the airbag applique (Figure 51).
50. Position the coat hooks onto the headliner and install the screws tightening securely into the mounting clips then close the screw cap fully (Figure 50).

Service Procedure [Continued]

51. Install the B-pillar upper trim panel (1) and engage the retaining clips fully (Figure 49).
52. Install the grab handle bolts (3) and tighten to 5 N·m (44 in. lbs.). Close the fastener covers (2) (Figure 49).
53. Remove and **DISCARD** the bolt retainer and the bolt from the seat belt turning loop, save the spacer washer for reuse (Figure 66).
54. Using a **NEW** bolt and reusing the spacer washer, install the turning loop then tighten the bolt to 40 N·m (30 ft. lbs.) (Figure 48).
55. Install the seat belt turning loop cover (Figure 48).
56. Position the B-pillar lower trim panel and engage the retaining clips fully (Figure 47).
57. Position the front and rear door sill scuff plates and engage the retainers (Figure 46).

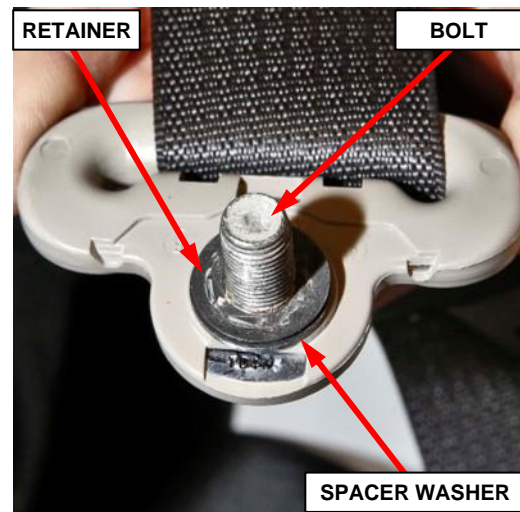
**Figure 66 – Turning Loop Bolt**

Service Procedure [Continued]

WARNING: Do not connect the negative battery cable at this time. The Supplemental Restraint System (SRS) Verification Test procedure should be performed following service of any SRS component.

NOTE: The following procedure should be performed using a diagnostic scan tool to verify proper Supplemental Restraint System (SRS) operation following the service or replacement of any SRS component. Refer to the appropriate diagnostic procedures.

58. During the following test, the negative cable remains disconnected and isolated from the battery, as it was during the Supplemental Restraint System (SRS) component removal and installation procedures.
59. Be certain that the diagnostic scan tool contains the latest version of the proper diagnostic software. Connect the scan tool to the 16-way Data Link Connector (DLC). The DLC is located on the driver side lower edge of the instrument panel, near the steering column opening cover and outboard of the steering column.
60. Transition the status of the ignition switch (also known as the Keyless Ignition Node/KIN or Ignition Node Module/IGNM) to ON and exit the vehicle with the scan tool.
61. Check to be certain that nobody is in the vehicle, then connect the negative cable to the battery.

Service Procedure [Continued]

78. Using the scan tool, read and record the active (current) Diagnostic Trouble Code (DTC) data.
79. Next, use the scan tool to read and record any stored (historical) DTC data.
80. If any SRS related DTC is found in the previous two steps, refer to the appropriate diagnostic information.
81. Use the scan tool to erase the stored DTC data. If any problems remain, the stored DTC data will not erase. Refer to the appropriate diagnostic information to diagnose any stored DTC that will not erase. If the stored DTC information is successfully erased, continue to the next step.
82. Transition the status of the ignition switch to OFF for about 15 seconds, and then back to ON. Observe the airbag indicator in the instrument cluster. It should light from four to six seconds, and then go out. This indicates that the SRS is functioning normally and that the repairs are complete. If the airbag indicator fails to light, or lights and stays ON, there is still an active SRS fault or malfunction. Refer to the appropriate diagnostic information to diagnose the problem.
83. Install the front seat headrests (Figure 45).
84. Position the locating tab of the A-pillar trim panel (2) into the slot located in the top of the instrument panel (Figure 44).
85. Install the A-pillar trim panel onto the A-pillar (1) and install the two bolts (4). Tighten the bolts to 5 N·m (44 in. lbs.) (Figure 44).
86. Close the two fastener covers (3) located in the A-pillar trim panel (Figure 44).
87. Install the door seals around the door openings.
88. Return the vehicle to the customer or inventory.

Service Procedure [Continued]

D. Mega Cab

1. Using a small flat-bladed tool, carefully open the two fastener covers (3) located in the A-pillar trim panel (2) (Figure 67).

2. Remove the two bolts (4) that secure the A-pillar trim panel to the A-pillar (1) and remove the trim panel (Figure 67).

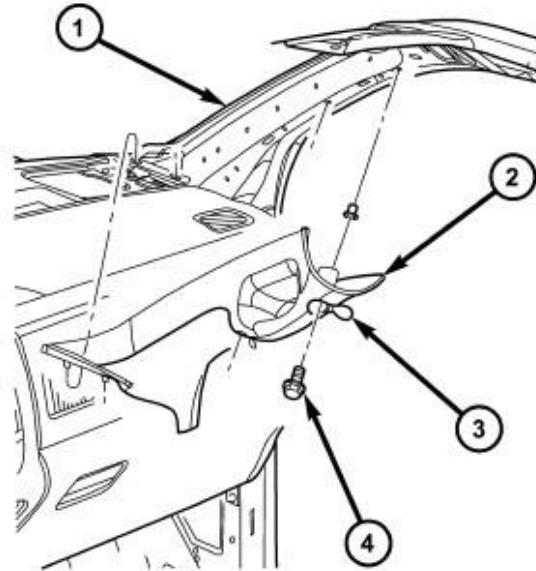

80d407a9

Figure 67 – A-Pillar

3. Push in the buttons on front seat headrest sleeves then pull the headrest up and remove (Figure 68).

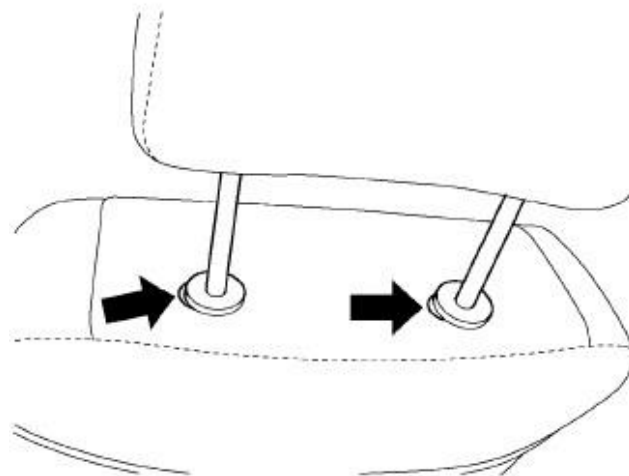

812oddd3

Figure 68 – Head Rest

4. Fold the seats forward.

Service Procedure [Continued]

5. Release the front and rear door sill scuff plates on either side of the B-pillar lower trim panel to allow for removal of the B-pillar lower trim panel (Figure 69).



Front Door Sill



Rear Door Sill

Figure 69 – Door Sill Scuff Plates

6. Release the retaining clips and remove the B-pillar lower trim panel to allow for removal of the B-pillar upper trim panel (Figure 70).

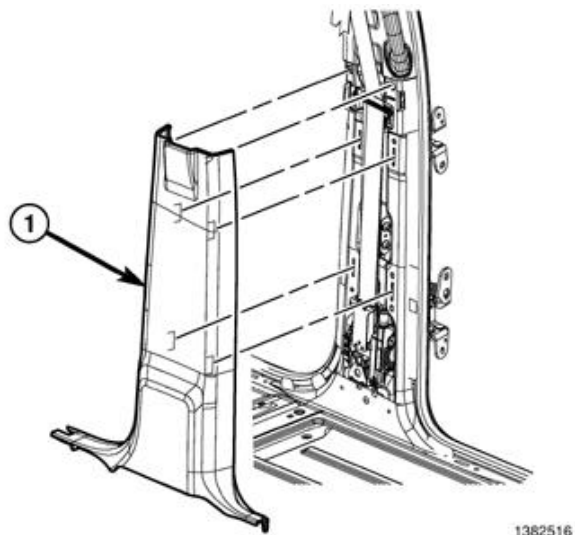

Figure 70 – B-Pillar Lower Trim Panel

Service Procedure [Continued]

7. On the B-pillar, separate the seatbelt turning loop cover then remove the turning loop bolt (Figure 71).

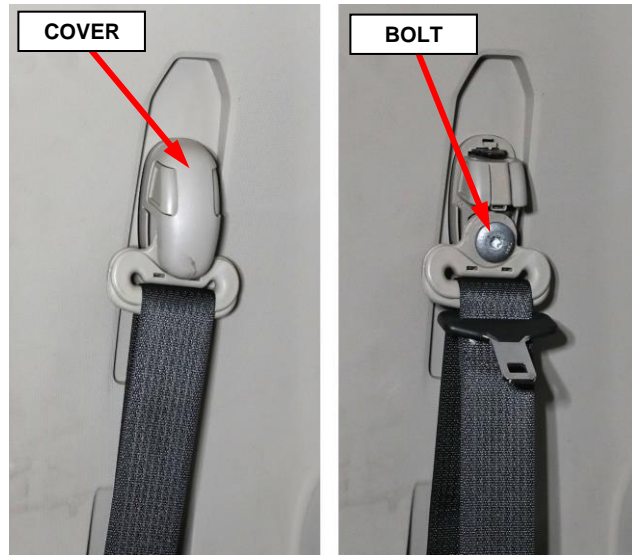

Figure 71 – Seat Belt Turning Loop

8. On the B-pillar, use a small flat-bladed tool to carefully open the two fastener covers (2) located on the grab handle (Figure 72).

9. Remove the two bolts (3) that secure the grab handle to the B-pillar (Figure 72).

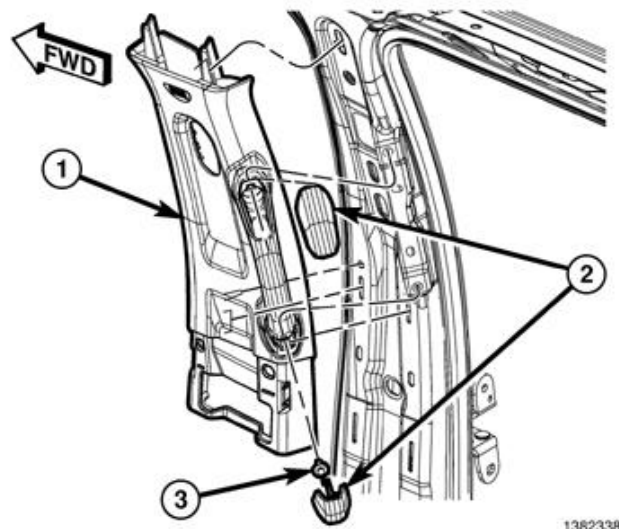

Figure 72 – B-Pillar Upper Trim Panel

10. Using a trim stick C-4755 or equivalent, release the retaining clips that secure the B-pillar upper trim panel (1) then position the trim panel out of the way. It is not necessary to remove the seat belt from the trim panel (Figure 72).

Service Procedure [Continued]

11. Fold the rear seat backs down.
12. Release the upper retaining clips of the lower C-pillar trim panel to allow for removal of the upper C-pillar trim panel (Figure 73).



Figure 73 – C-Pillar Lower Trim Panel

13. On the C-pillar, lift the seat belt turning loop cover then remove the turning loop bolt (Figure 74).

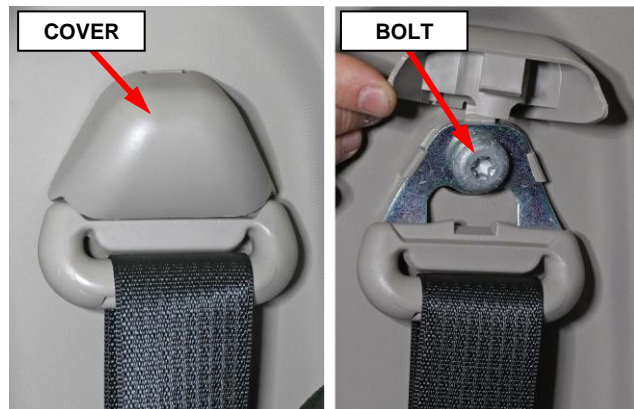

Figure 74 – Seat Belt Turning Loop

Service Procedure [Continued]

14. Using a trim stick or equivalent, release the B-pillar airbag applique then remove the screw that secures the upper trim panel (Figure 75).

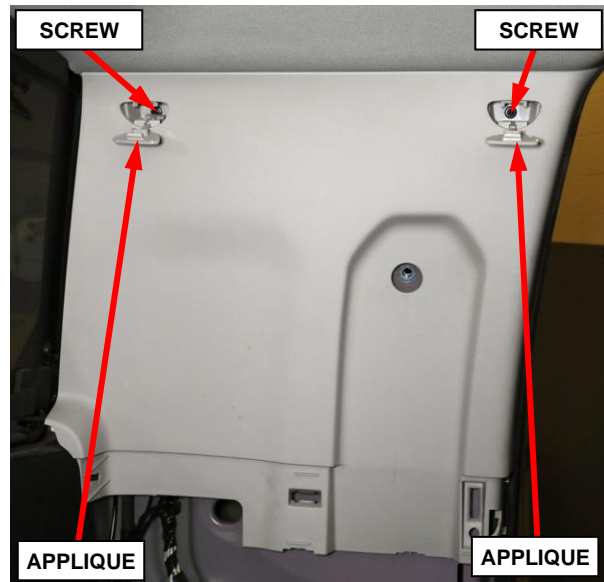

Figure 75 – C-Pillar Upper Trim Panel Fasteners

15. Release the retaining clips and remove the C-pillar upper trim panel (1) (Figure 76).

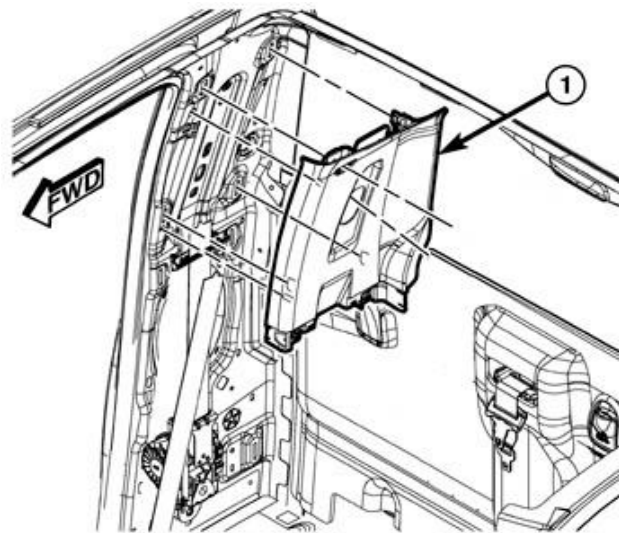

Figure 76 – C-Pillar Upper Trim Panel

16. Recline the front seat backs to allow for room to lower the headliner.

Service Procedure [Continued]

17. Disconnect and isolate the negative battery cable. If equipped with an Intelligent Battery Sensor (IBS), disconnect the IBS connector first before disconnecting the negative battery cable. Wait two minutes for the system capacitor to discharge before further service.

WARNING: To avoid serious or fatal injury on vehicles equipped with airbags, disable the Supplemental Restraint System (SRS) before attempting any steering wheel, steering column, airbag, seat belt tensioner, impact sensor or instrument panel component diagnosis or service. Disconnect and isolate the battery negative (ground) cable, then wait two minutes for the system capacitor to discharge before performing further diagnosis or service. This is the only sure way to disable the SRS. Failure to take the proper precautions could result in accidental airbag deployment.

WARNING: To avoid serious or fatal injury when removing a deployed airbag, rubber gloves, eye protection, and a long-sleeved shirt should be worn. There may be deposits on the airbag unit and other interior surfaces. In large doses, these deposits may cause irritation to the skin and eyes.

WARNING: To avoid serious or fatal injury, use extreme care to prevent any foreign material from entering the side curtain airbag, or becoming entrapped between the side curtain airbag cushion and the headliner. Failure to observe this warning could result in occupant injuries upon airbag deployment.

NOTE: The following procedure is for replacement of an ineffective or damaged side curtain airbag (also known as Side Air Bag Inflatable Curtain/SABIC). If the airbag is ineffective or damaged, but not deployed, review local ordinances regarding recommended procedures for handling and disposal of Non-Deployed Supplemental Restraints.

NOTE: If a side curtain airbag is being removed, but has not been deployed, the headliner does not need to be removed from the passenger compartment. Lowering the headliner and resting it on the seat backs will allow enough clearance to remove the side curtain airbag from the vehicle.

Service Procedure [Continued]

CAUTION: Hands should be clean or clean cloth gloves used when handling the visors and headliner to avoid marks or damage.

18. If equipped with DVD monitor, remove the screws (2) and separate the monitor (1) from the roof (Figure 77).

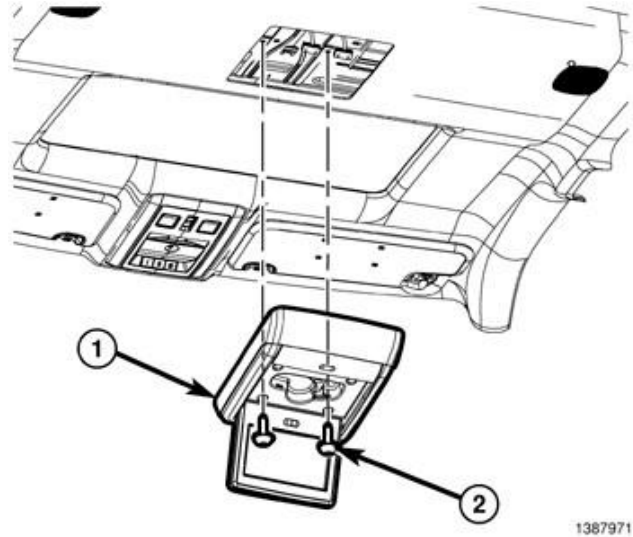

Figure 77 – Rear Seat DVD Monitor

19. If equipped with DVD monitor, disconnect the electrical connectors (1) (Figure 78).

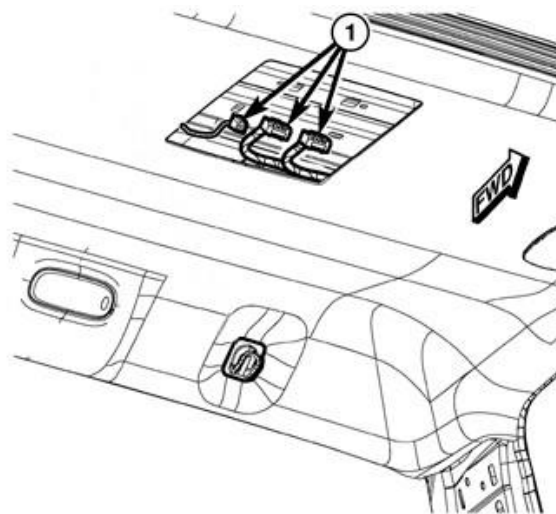

Figure 78 – DVD Monitor Electrical Connectors

Service Procedure [Continued]

20. Separate the visor from the support (1) then remove the screw and remove the visor support (Figure 79).

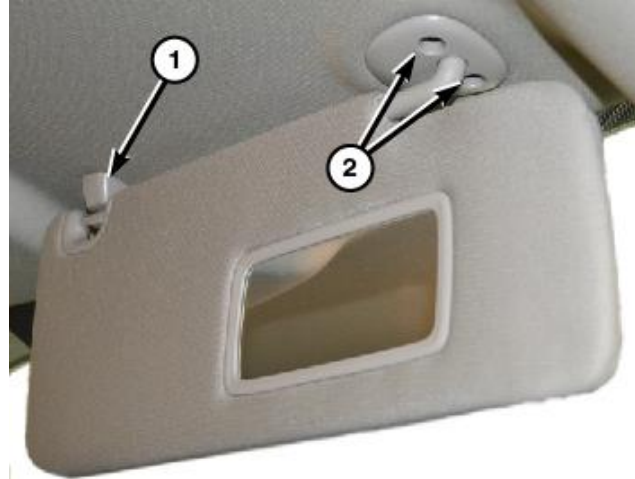

Figure 79 – Visors

21. Remove the visor screws (2) then remove the visor (Figure 79).

Using a small flat bladed tool or equivalent, release the retaining tabs (1) and separate the visor from the headliner (Figure 80).

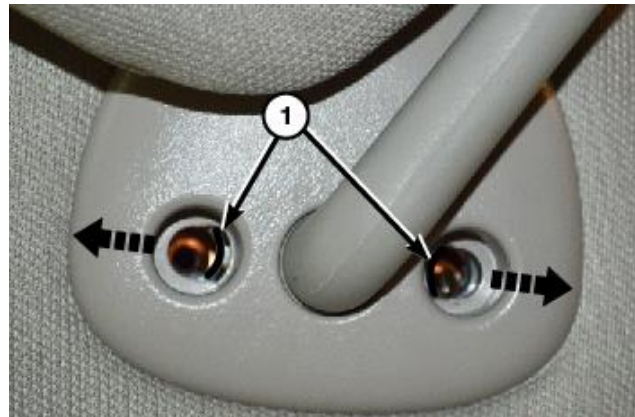

Figure 80 – Visors

22. Disconnect the visor electrical connector if equipped.

NOTE: In some cases, the wire harness for the visor vanity mirror may be glued to the top side of the headliner and may be a little difficult to release.

23. Using a small flat bladed tool, open the coat hook screw cover (2) then remove the screw and coat hook (Figure 81).

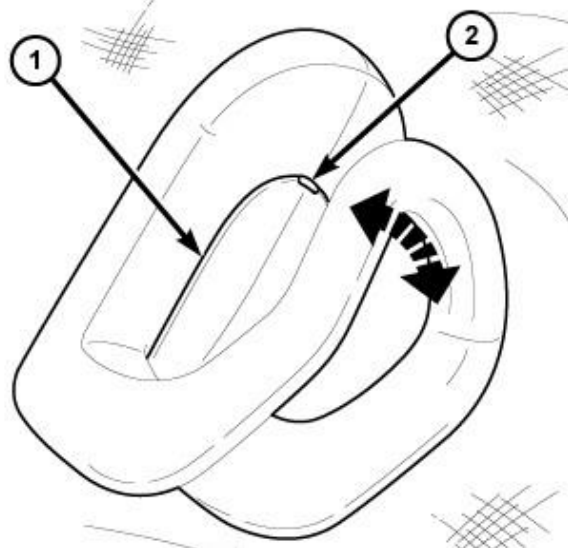

Figure 81 – Coat Hook

Service Procedure [Continued]

24. As necessary, release the headliner wiring harness clips (3) from the A-pillar to allow enough wiring harness slack for lowering the headliner (Figure 82).

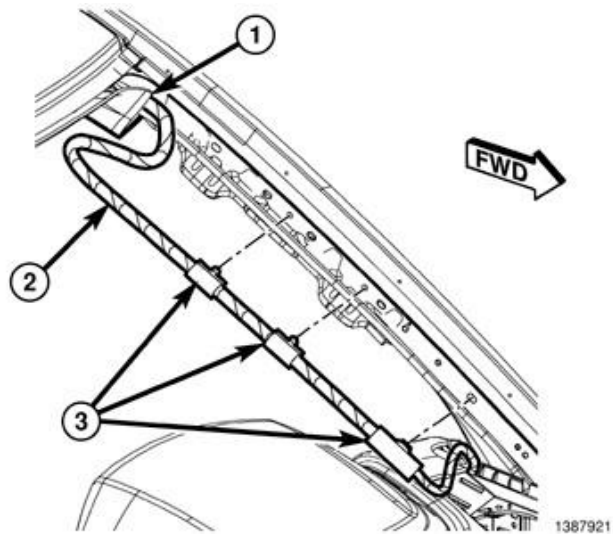

Figure 82 – Headliner Harness

25. Release the door seals from the door openings to allow for lowering of the headliner.

26. Carefully lower the headliner (2) allowing it to rest on the seat backs and instrument panel (Figure 83).

CAUTION: Disconnect any wiring harness electrical connectors (1) as necessary to allow enough wiring harness slack while lowering headliner. It will not be necessary to remove the headliner from the vehicle (Figure 83).

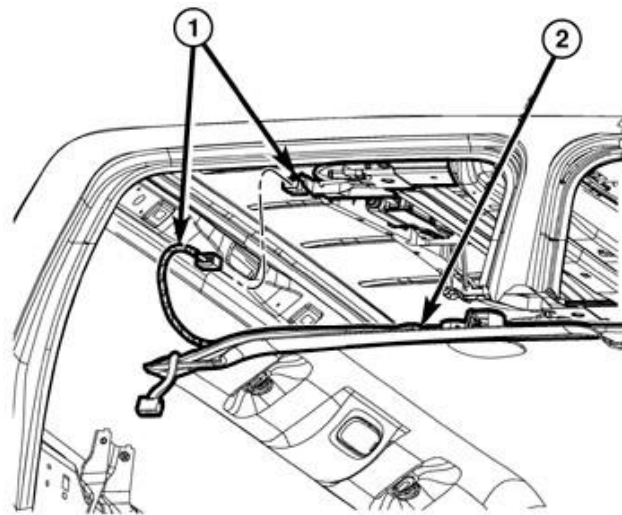

Figure 83 – Headliner Harness

Service Procedure [Continued]

- 27. Locate the label on SABIC inflators. The traceability number will begin with TCL3Uxxxxxxxx for the left side or TCR3Vxxxxxxxx for the right side as shown in (Figure 84).

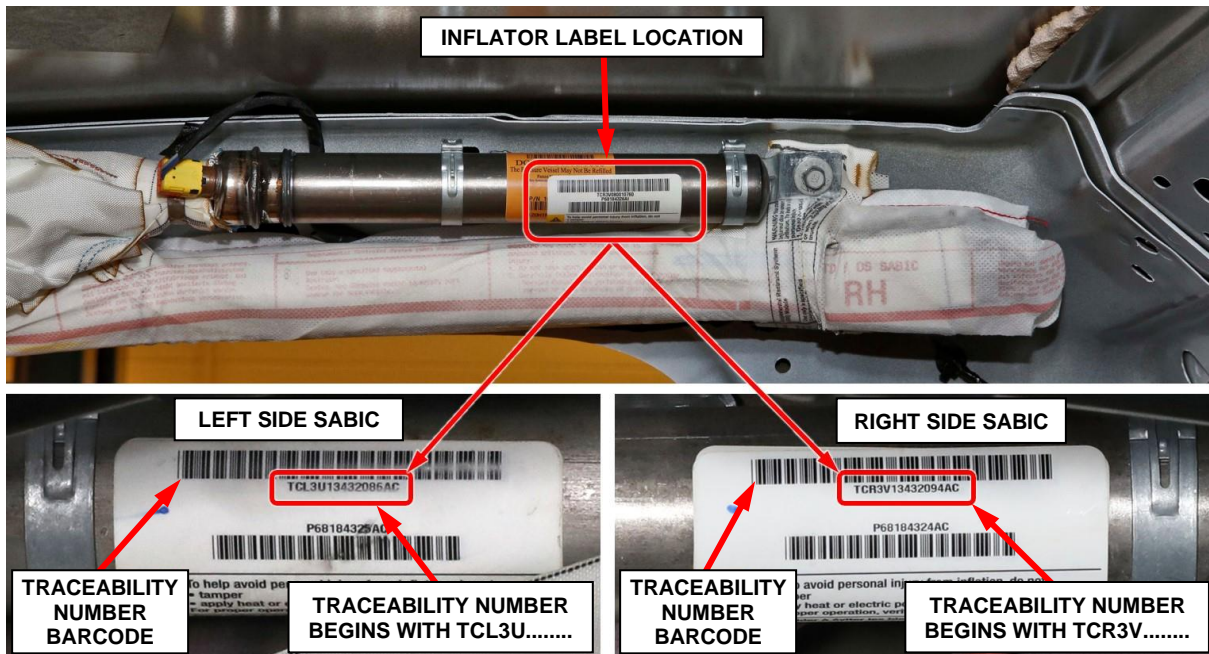



Figure 84 – SABIC Inflator Traceability Number Inspection

NOTE: A smartphone, tablet, or computer may be used for the following inspection process. Smartphone or tablet is the preferred method.

- 28. Sign into **Service Library** then enter the **Vehicle Identification Number (VIN)** and ensure you are viewing **Safety Recall Y63** service instructions. This header shown in (Figure 85) will appear above the service instructions.

Please type or scan the traceability numbers below for part verification

Left side inflator (starts with TCL3U) 

Right side inflator (starts with TCR3V) 

Figure 85 – SABIC Traceability Number Verification

Service Procedure [Continued]

29. There are **two** methods described below which may be used to inspect the right side and left side SABIC inflator traceability numbers.

NOTE: There are separate entry fields and barcode icons for right side and left side traceability numbers. Using the incorrect entry field or icon meant for the opposite side will not work.

- **Method 1:** Using a smartphone or tablet held vertically, click on the barcode scanner icon (Figure 87) to open the barcode scan function. Ensure the device camera is enabled and device is held vertically. Aim the camera directly at the SABIC traceability number barcode as shown in (Figure 86). The barcode scanner will automatically record the barcode and populate the traceability number entry field (Figure 87). Scan the barcodes for the left side and right side SABIC inflators.

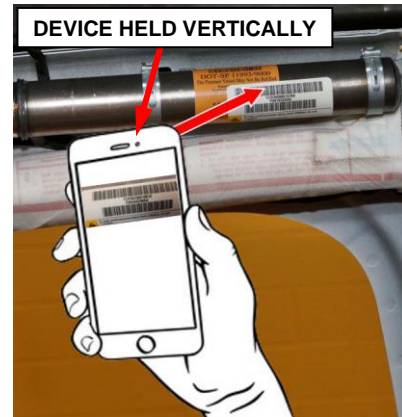

Figure 86 – Scan Barcode

- **Method 2:** Type all letters and numbers of the right side and left side SABIC inflator traceability numbers in their respective fields shown in (Figure 87).

TYPE ALL LETTERS AND NUMBERS OF THE TRACEABILITY NUMBER IN THE ENTRY FIELD

OR

CLICK THE BARCODE ICON THEN SCAN THE TRACEABILITY NUMBER BARCODE

Please type or scan the traceability numbers below for part verification

Left side inflator (starts with TCL3U)	TCL3Uxxxxxxxxx		<input type="button" value="VERIFY"/>
Right side inflator (starts with TCR3V)	TCR3Vxxxxxxxxx		<input type="button" value="VERIFY"/>

Figure 87 – Type or Scan the SABIC Traceability Number

30. Click the **VERIFY** button to the right of the traceability numbers (Figure 87).

Service Procedure [Continued]

31. Ensure both right and left SABIC traceability numbers have been checked. The traceability number verification system will return one of three possible responses for each inflator:
- *The traceability number entered is affected and the part replacement should be performed. **Suspect inflator – replace SABIC.***
 - *The traceability number entered is not affected by this recall. **Not suspect inflator – do not replace SABIC.***
 - *The traceability number entered appears to be incorrect. **Please check the number and try again.***

If verification system identified a suspect inflator affected by this recall, that SABIC must be replaced. Order the appropriate SABIC then continue with **Step 32** and replace only those SABICs that have an inflator which was identified as suspect.

If verification system identified an inflator as not suspect and not affected by this recall, that SABIC does not require replacement. Proceed to **Step 43** for any inflators which were identified as not suspect.

Service Procedure [Continued]

32. The body wire harness connector (5) is secured by integral latches to the connector receptacle on the inflator (4). Pinch both latches firmly, then pull the connector straight out from the airbag inflator to disconnect it from the connector receptacle (Figure 88).
33. Remove the seven bolts (8) that secure the side curtain airbag (6) to the inner roof rail and A-pillar (Figure 88).
34. Disengage the plastic push-in retainer (9) that secures the side curtain airbag tether to the inner A-pillar (1) and the plastic push-in retainer (7) that secures the side curtain airbag to the inner roof rail (Figure 88).
35. Slide the inflator rearward far enough to disengage the T-tab at the front of the inflator bracket from the keyed T-slot in the inner roof rail over the rear door opening (Figure 89).
36. Remove the SABIC (6) from the vehicle as a unit and **DISCARD** following local ordinances and recommended procedures for handling and disposal of Non-Deployed Supplemental Restraints (Figure 88).

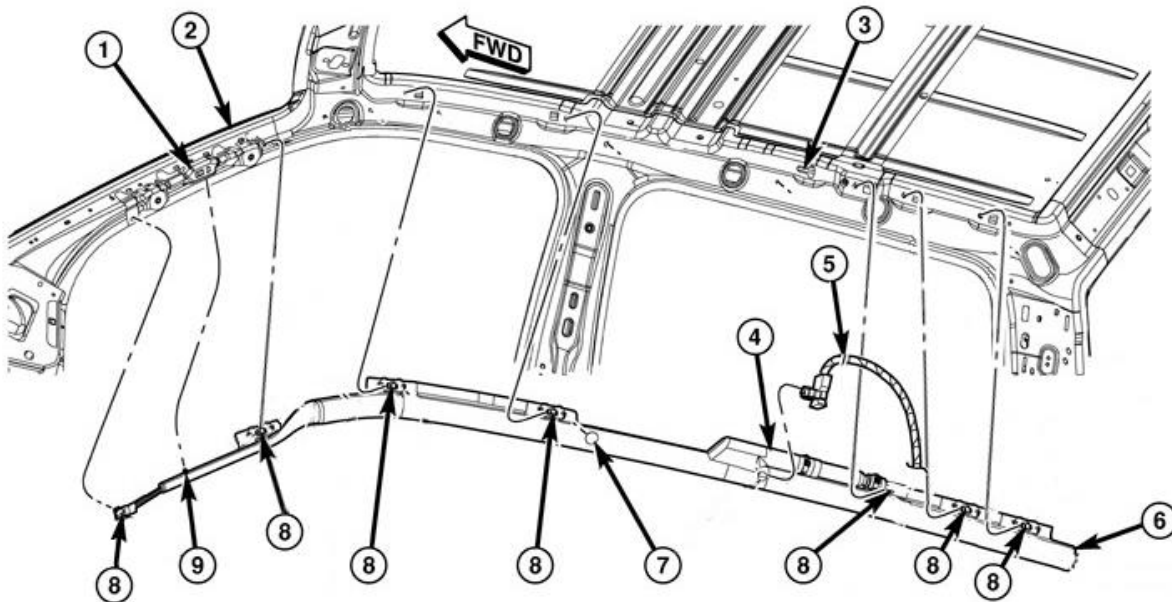
**Figure 88 – SABIC**

Service Procedure [Continued]

Figure 89 – SABIC Inflator T-Tab and Inner Roof Rail T-Slot

37. Check to be certain that the spring nuts are properly installed in the inner roof rail and that they are in good condition.
38. Position the **NEW SABIC** (6) into the vehicle as a unit (Figure 88).
39. Insert the T-tab at the front of the inflator bracket into the keyed T-slot in the inner roof rail over the rear door opening and slide the inflator forward to engage it (Figure 89).
40. Engage the plastic push-in retainer (7) that secures the side curtain airbag to the inner roof rail and ensure the tether is not twisted then engage the plastic push-in retainer (9) that secures the side curtain airbag front tether to the assist handle bracket on the inner A-pillar (1) (Figure 88).
41. Working from rear to front, install and tighten the seven bolts (8) that secure the side curtain airbag (6) to the inner roof rail and A-pillar. Tighten the bolts to 7 N·m (62 in. lbs.) (Figure 88).
42. Connect the body wire harness connector (5) for the side curtain airbag to the connector receptacle of the inflator (4). Be certain that each connector is fully engaged in its receptacle by listening carefully for a distinct, audible click as the connector latches snap into place (Figure 88).

Service Procedure [Continued]

CAUTION: Hands should be clean or clean cloth gloves used when handling the headliner to avoid damage to the headliner.

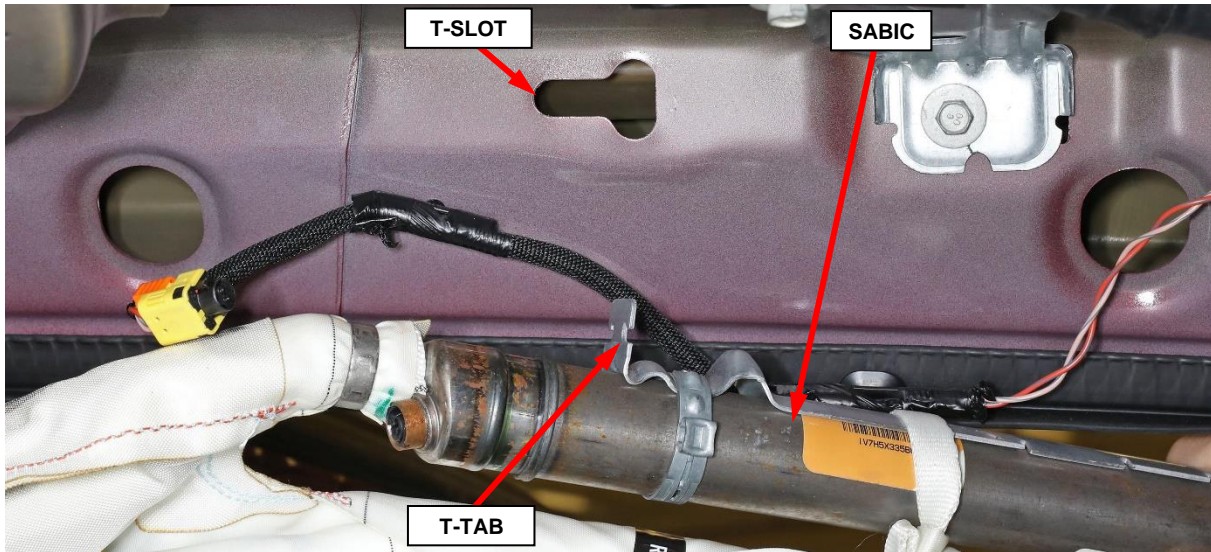
43. Raise the headliner into proper vehicle position and connect any electrical connectors previously disconnected from the headliner (Figure 83).

CAUTION: Be certain to avoid any wiring or drain tube interference.

44. Position the coat hooks (5) onto the headliner and install the screws tightening securely into the mounting clips then close the screw cap fully (Figure 81).
45. Position the visor supports (1) onto the headliner and install the screws into the mounting clips (Figure 79).
46. If equipped with illuminated vanity mirror, connect the wire harness connector.
47. Position the visor to the headliner and install the screws (2) that secure the visor to the roof panel. Tighten the screws to 6 N·m (53 in. lbs.) (Figure 79).
48. Reattach any headliner wiring harness clips (3) removed from the A-pillar to allow slack while lowering headliner (Figure 82).
49. If equipped with DVD monitor, connect the DVD monitor electrical connectors (1) (Figure 78). Position the DVD monitor to the roof then install and tighten the screws (2) (Figure 77).

WARNING: Do not connect the negative battery cable at this time. The Supplemental Restraint System (SRS) Verification Test procedure should be performed following service of any SRS component.

NOTE: The following procedure should be performed using a diagnostic scan tool to verify proper Supplemental Restraint System (SRS) operation following the service or replacement of any SRS component. Refer to the appropriate diagnostic procedures.

Service Procedure [Continued]

50. During the following test, the negative cable remains disconnected and isolated from the battery, as it was during the Supplemental Restraint System (SRS) component removal and installation procedures.
51. Be certain that the diagnostic scan tool contains the latest version of the proper diagnostic software. Connect the scan tool to the 16-way Data Link Connector (DLC). The DLC is located on the driver side lower edge of the instrument panel, near the steering column opening cover and outboard of the steering column.
52. Transition the status of the ignition switch (also known as the Keyless Ignition Node/KIN or IGnition Node Module/IGNM) to ON and exit the vehicle with the scan tool.
53. Check to be certain that nobody is in the vehicle, then connect the negative cable to the battery.
54. Using the scan tool, read and record the active (current) Diagnostic Trouble Code (DTC) data.
55. Next, use the scan tool to read and record any stored (historical) DTC data.
56. If any SRS related DTC is found in the previous two steps, refer to the appropriate diagnostic information.
57. Use the scan tool to erase the stored DTC data. If any problems remain, the stored DTC data will not erase. Refer to the appropriate diagnostic information to diagnose any stored DTC that will not erase. If the stored DTC information is successfully erased, continue to the next step.
58. Transition the status of the ignition switch to OFF for about 15 seconds, and then back to ON. Observe the airbag indicator in the instrument cluster. It should light from four to six seconds, and then go out. This indicates that the SRS is functioning normally and that the repairs are complete. If the airbag indicator fails to light, or lights and stays ON, there is still an active SRS fault or malfunction. Refer to the appropriate diagnostic information to diagnose the problem.

Service Procedure [Continued]

59. Raise the front seat backs and position the seats forward.
60. Install the C-pillar upper trim panel (1) and engage the retaining clips fully (Figure 76).
61. Install and tighten the screws that secure the C-pillar upper trim panel then install the airbag applique covers (Figure 75).
62. Remove and **DISCARD** the bolt retainer and the bolt from the seat belt turning loop, save the spacer for reuse (Figure 90).
63. Using a **NEW** bolt and reusing the spacer washer, install the turning loop then tighten the bolt to 40 N·m (30 ft. lbs.) (Figure 74).
64. Install the seat belt turning loop cover (Figure 74).
65. Position the lower C-pillar trim panel and engage the retaining clips fully (Figure 73).

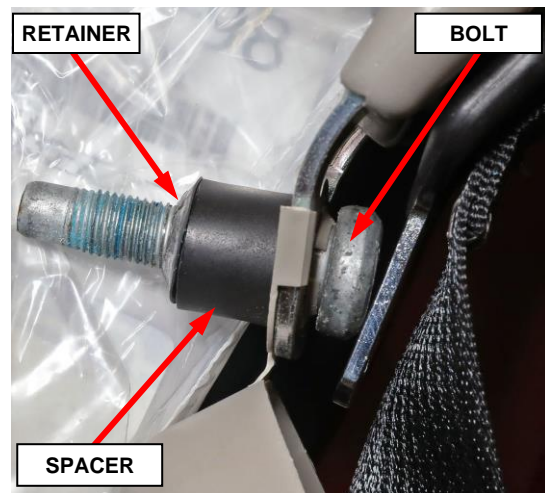
**Figure 90 – Turning Loop Bolt**

NOTE: Ensure that all C-pillar fasteners are installed/engaged properly.

66. Install the B-pillar upper trim panel (1) and engage the retaining clips fully (Figure 72).
67. Install the grab handle bolts and tighten to 5 N·m (44 in. lbs.). Close the fastener covers (2) (Figure 72).

Service Procedure [Continued]

68. Remove and **DISCARD** the bolt retainer and the bolt from the seat belt turning loop, save the spacer washer for reuse (Figure 91).
69. Using a **NEW** bolt and reusing the spacer washer, install the turning loop then tighten the bolt to 40 N·m (30 ft. lbs.) (Figure 71).
70. Install the seat belt turning loop cover (Figure 71).
71. Position the B-pillar lower trim panel and engage the retaining clips fully (Figure 70).
72. Position the front and rear door sill scuff plates and engage the retainers (Figure 69).
73. Install the front seat headrests (Figure 68).
74. Position the locating tab of the A-pillar trim panel (2) into the slot located in the top of the instrument panel (Figure 67).
75. Install the A-pillar trim panel onto the A-pillar (1) and install the two bolts (4). Tighten the bolts to 5 N·m (44 in. lbs.) (Figure 67).
76. Close the two fastener covers (3) located in the A-pillar trim panel (Figure 67).
77. Install the door seals around the door openings.
78. Return the vehicle to the customer or inventory.

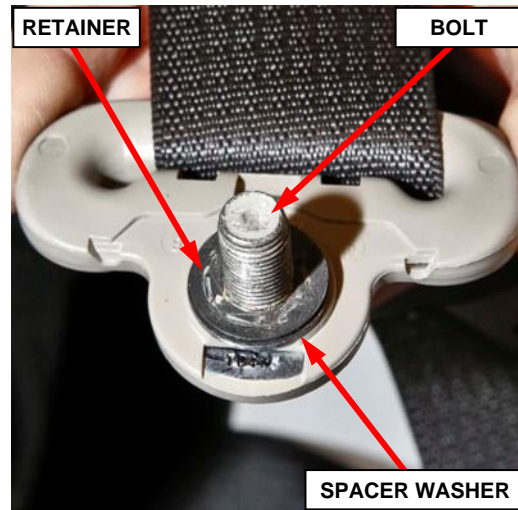
**Figure 91 – Turning Loop Bolt**

Completion Reporting and Reimbursement

Claims for vehicles that have been serviced must be submitted on the DealerCONNECT Claim Entry Screen located on the Service tab. Claims paid will be used by FCA to record recall service completions and provide dealer payments.

Use the following labor operation numbers and time allowances:

	Labor Operation Number	Time Allowance
Inspect: Both SABICs are not on suspect list. <i>(Inspection LOP 23-Y6-31-81 must be combined with <u>ONE</u> of the Related Inspection LOPs below)</i>	23-Y6-31-81	0.1 hours

Repair LOPs include Removal and Installation of Headliner

Inspect/Replace One SABIC (Standard Cab)	23-Y6-31-82	1.4 hours
Inspect/Replace One SABIC (Crew/Quad Cab)	23-Y6-31-83	1.7 hours
Inspect/Replace One SABIC (Mega Cab)	23-Y6-31-84	2.2 hours
Inspect/Replace Two SABICs (Standard Cab)	23-Y6-31-85	1.6 hours
Inspect/Replace Two SABICs (Crew/Quad Cab)	23-Y6-31-86	2.0 hours
Inspect/Replace Two SABICs (Mega Cab)	23-Y6-31-87	2.7 hours

Related Inspection LOPs include Removal and Installation of Headliner

These related LOPs are to be combined with inspection LOP 23-Y6-31-81 ONLY

Inspect both SABICs (Standard Cab)	23-Y6-31-50	1.1 hours
Inspect both SABICs (Crew/Quad Cab)	23-Y6-31-51	1.4 hours
Inspect both SABICs (Mega Cab)	23-Y6-31-52	1.8 hours

Add the cost of the recall parts plus applicable dealer allowance to your claim.

NOTE: See the Warranty Administration Manual, Recall Claim Processing Section, for complete recall claim processing instructions.

Dealer Notification

To view this notification on DealerCONNECT, select “Global Recall System” on the Service tab, then click on the description of this notification.

Owner Notification and Service Scheduling

All involved vehicle owners known to FCA are being notified of the service requirement by first class mail. They are requested to schedule appointments for this service with their dealers. A generic copy of the owner letter is attached.

Vehicle Lists, Global Recall System, VIP and Dealer Follow Up

All involved vehicles have been entered into the DealerCONNECT Global Recall System (GRS) and Vehicle Information Plus (VIP) for dealer inquiry as needed.

GRS provides involved dealers with an updated VIN list of their incomplete vehicles. The owner’s name, address and phone number are listed if known. Completed vehicles are removed from GRS within several days of repair claim submission.

To use this system, click on the “**Service**” tab and then click on “**Global Recall System.**” Your dealer’s VIN list for each recall displayed can be sorted by: those vehicles that were unsold at recall launch, those with a phone number, city, zip code, or VIN sequence.

Dealers must perform this repair on all unsold vehicles before retail delivery. Dealers should also use the VIN list to follow up with all owners to schedule appointments for this repair.

Recall VIN lists may contain confidential, restricted owner name and address information that was obtained from the Department of Motor Vehicles of various states. Use of this information is permitted for this recall only and is strictly prohibited from all other use.

Additional Information

If you have any questions or need assistance in completing this action, please contact your Service and Parts District Manager.

Customer Services / Field Operations
FCA US LLC

This notice applies to your vehicle.

[Model Year and Model]

VIN XXXXXXXXXXXXXXXXXXXX

Y63/NHTSA 21V-632

LOGO

VEHICLE PICTURE

YOUR SCHEDULING OPTIONS

1. RECOMMENDED OPTION

Call your authorized Chrysler / Dodge / Jeep® / RAM] Dealership

2. Call the FCA Recall Assistance Center at 1-800-853-1403. An agent can confirm part availability and help schedule an appointment

3. Visit recalls.mopar.com, scan the QR code below, or download the Mopar Owner's Companion App.

QR Code

Get access to recall notifications, locate your nearest dealer, and more through this website or Mopar Owner's Companion App. You will be asked to provide your Vehicle Identification Number (VIN) to protect and verify your identity. The last eight characters of your VIN are provided above.

DEALERSHIP INSTRUCTIONS

Please reference Safety Recall Y63.

IMPORTANT SAFETY RECALL

Side Air Bag Inflatable Curtain

Dear [Name],

This notice is sent to you in accordance with the National Traffic and Motor Vehicle Safety Act.

FCA US has decided that a defect, which relates to motor vehicle safety, exists in certain [2015-2020 Model Year (DS) Ram 1500 Pickup, 2015-2016 Model Year (DJ) Ram 2500 Pickup, (D2) Ram 3500 Pickup, and 2016 Model Year (DF) Ram 3500 10K lbs. Cab Chassis] vehicles.

It is extremely important to take steps now to repair your vehicle to ensure the safety of you and your passengers.

WHY DOES MY VEHICLE NEED REPAIRS?

The Side Air Bag Inflatable Curtain (SABIC) inflator on your vehicle ^[1] may rupture. A SABIC inflator rupture may result in compressed gas rapidly escaping from the inflator and material potentially being propelled into the vehicle. **Material being propelled into the vehicle may cause injury to vehicle occupants.**

HOW DO I RESOLVE THIS IMPORTANT SAFETY ISSUE?

FCA US will repair your vehicle ^[2] free of charge (parts and labor). To do this, your dealer will inspect and if necessary, replace one or both SABIC's as needed. The estimated repair time is 3 hours. In addition, your dealer will require your vehicle for proper check-in, preparation, and check-out during your visit, which may require more time. Your time is important to us, so we recommend that you schedule a service appointment to minimize your inconvenience. Please bring this letter with you to your dealership.

TO SCHEDULE YOUR FREE REPAIR, CALL YOUR CHRYSLER, DODGE, JEEP OR RAM DEALER TODAY

WHAT IF I ALREADY PAID TO HAVE THIS REPAIR COMPLETED?

If you have already experienced this specific condition and have paid to have it repaired, you may visit www.fcarecallreimbursement.com to submit your reimbursement request online. ^[3] Once we receive and verify the required documents, reimbursement will be sent to you within 60 days. If you have had previous repairs performed and/or already received reimbursement, you may still need to have the recall repair performed.

We apologize for any inconvenience, but are sincerely concerned about your safety. Thank you for your attention to this important matter.

Customer Assistance/Field Operations
FCA US LLC



Mr. Mrs. Customer
1234 Main Street
Hometown, MI 48371

[1] If you no longer own this vehicle, please help us update our records. Call the FCA Recall Assistance Center at 1-800-853-1403 to update your information.

[2] If your dealer fails or is unable to remedy this defect without charge and within a reasonable time, you may submit a written complaint to the Administrator, National Highway Traffic Safety Administration, 1200 New Jersey Ave., S.E., Washington, DC 20590, or you can call the toll-free Vehicle Safety Hotline at 1-888-327-4236 (TTY 1-800-424-9153), or go to safercar.gov.

[3] You can also mail in your original receipts and proof of payment to the following address for reimbursement consideration: FCA Customer Assistance, P.O. Box 21-8004, Auburn Hills, MI 48321-8007, Attention: Recall Reimbursement.

Note to lessors receiving this recall notice: Federal regulation requires that you forward this recall notice to the lessee within 10 days.