



# SAFETY RECALL BULLETIN

SUBJECT:			No: <b>SR-21-007REV2</b>
<b>SEAT BELT AUTOMATIC LOCKING RETRACTOR (ALR) – SAFETY RECALL CAMPAIGN - REVISION</b>			DATE: <b>November 2021</b>
			MODEL: <b>2022 Outlander</b>
<b>CIRCULATE TO:</b>	<input checked="" type="checkbox"/> GENERAL MANAGER	<input checked="" type="checkbox"/> PARTS MANAGER	<input checked="" type="checkbox"/> TECHNICIAN
<input checked="" type="checkbox"/> SERVICE ADVISOR	<input checked="" type="checkbox"/> SERVICE MANAGER	<input checked="" type="checkbox"/> WARRANTY PROCESSOR	<input checked="" type="checkbox"/> SALES MANAGER

This Safety Recall bulletin supersedes SR-21-007REV issued September 2021, to update the Repair Procedure section.

The purpose of this revision is to raise awareness to the need for extra caution when removing the locking button on the seat belt pre-tensioner connector. Please see page 11 of this recall for additional information. Revisions are italicized and indicated by:

## **PURPOSE**

This Campaign Bulletin provides instructions for inspecting the lot number on the passenger front and two outboard (left and right) 2<sup>nd</sup> row seat belts and replacing the seatbelt(s), if necessary.

## **BACKGROUND**

The Automatic Locking Retractor (ALR) function of the subject seat belt assemblies may deactivate before the webbing is fully retracted due to dimensionally out of tolerance ALR levers. This condition, if it exists, does not comply with Federal Motor Vehicle Safety Standard (FMVSS) 208. If the ALR function deactivates while an affected seat belt is used to secure a child restraint seat, the child restraint seat may not be tightly secured, which increases risk of serious injury or death.

## **AFFECTED VEHICLES**

Certain 2022 Outlander vehicles

## **IMPORTANT**

Affected new or used inventory vehicles must be repaired before the vehicle is sold/delivered. Dealers must check their inventory vehicles' VINs on the Warranty Superscreen to verify whether the vehicle is involved in this recall campaign. It is a violation of Federal law for a dealer to sell/deliver a new motor vehicle or any new or used item of motor vehicle equipment (including a tire) covered by the notification under a sale or lease until the defect or noncompliance is remedied.

## **CUSTOMER NOTIFICATION**

A letter will be sent to all owners of all potentially affected vehicles telling them to contact their local Authorized Mitsubishi Motors dealer for an inspection of the affected seatbelts and replacement if necessary. A copy of the customer notification letter appears at the end of this bulletin.

## **WARRANTY**

MMNA reserves the right to request photos be uploaded into the PRC for review. If requested, please complete request within 72 business hours. Please note it is imperative that dealers place the affected seatbelts into the original packaging and remain undamaged until final determination of warranty part return status. Warranty Parts Returns will only be accepted when shipped in original packaging.

Copyright 2021, Mitsubishi Motors North America, Inc.

The information contained in this bulletin is subject to change. For the latest version of this document, go to the Mitsubishi Dealer Link, MEDIC, or the Mitsubishi Service Information website ([www.mitsubishitechinfo.com](http://www.mitsubishitechinfo.com)).

## WORK FLOW

**NG** = NG = The lot "ID.NO." is contained in the affected numbers indicated below  
**OK** = OK = The lot "ID.NO." is **NOT** contained in the affected numbers indicated below  
(See Page 4 of this bulletin for affected lot "ID.NO." numbers)

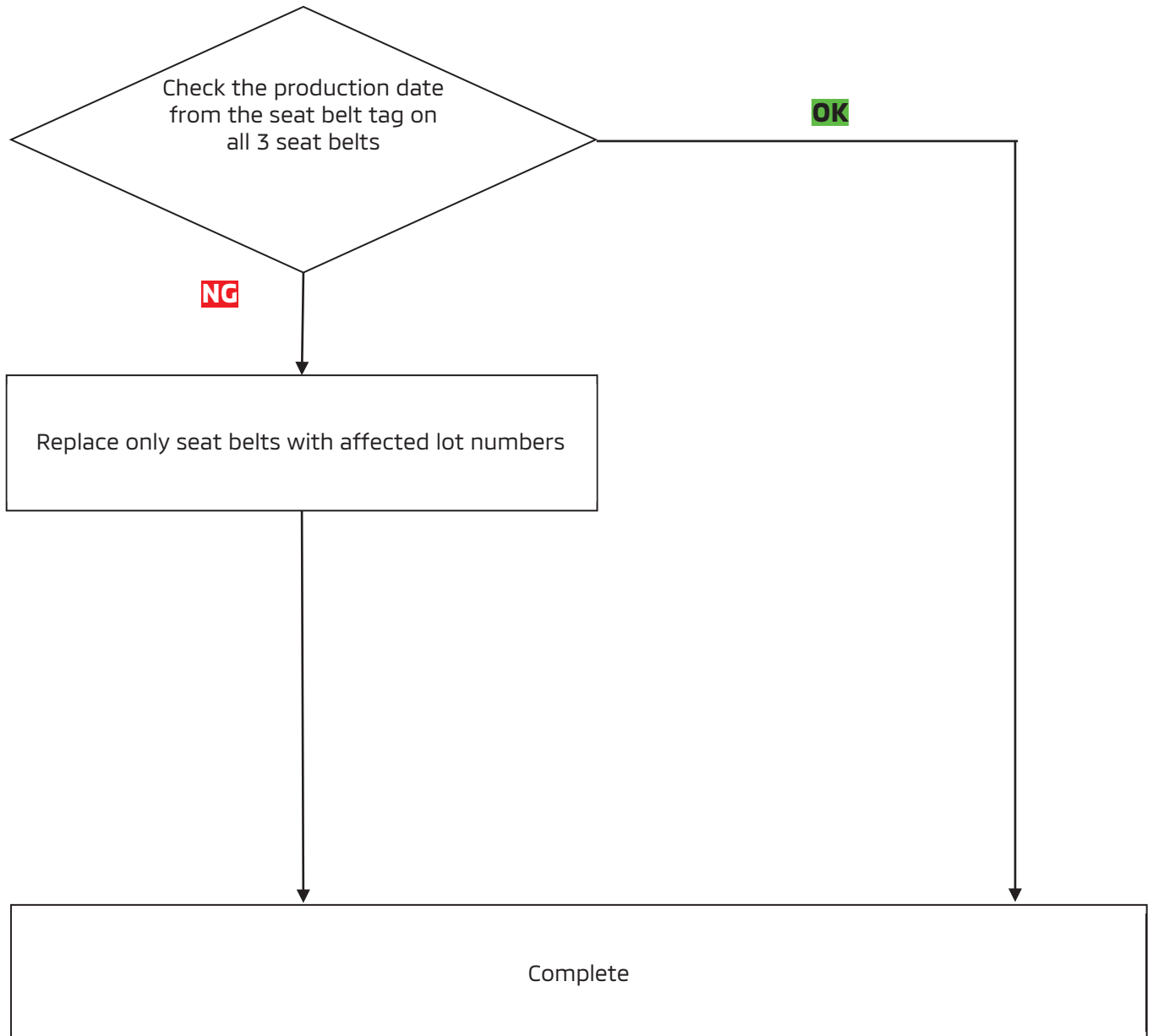

## **INSPECTION PROCEDURE**

### 1. SEATBELT TAG PASSENGER SIDE FRONT

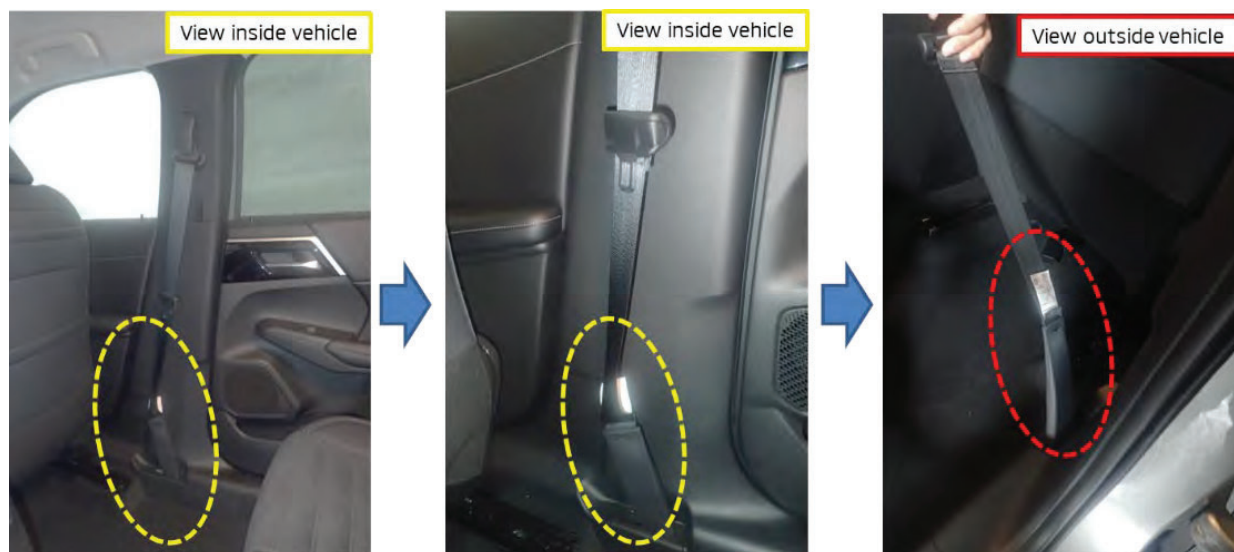

### 2. SEATBELT TAG 2<sup>ND</sup> ROW – LEFT AND RIGHT



**FIGURE 1: TAG LOCATION**

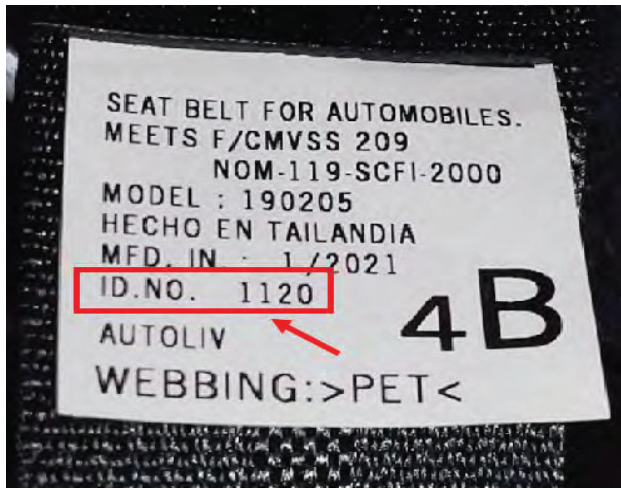

Sample : OK Tag



Sample: NG Tag

- **Affected production period:**  
Dec/19/2020 - Jan/18/2021
- **How to check the Lot ID. NO.**  
「ID.NO. : YMDD (4 digits)」

Y (Year) : 0 : 2020, 1 : 2021

M (Month) : 1 - 9 = Jan - Sep, X,Y,Z : Oct, Nov, Dec

DD(Date) : 01 - 31 = 1<sup>st</sup> - 31<sup>th</sup>

- **Affected Lot ID. NO. : 0Z19 - 1118**

**!! IMPORTANT !!**

**Listing of Affected Lot Numbers**

<b>0Z19</b>	<b>1101</b>	<b>1114</b>
<b>0Z20</b>	<b>1102</b>	<b>1115</b>
<b>0Z21</b>	<b>1103</b>	<b>1116</b>
<b>0Z22</b>	<b>1104</b>	<b>1117</b>
<b>0Z23</b>	<b>1105</b>	<b>1118</b>
<b>0Z24</b>	<b>1106</b>	
<b>0Z25</b>	<b>1107</b>	
<b>0Z26</b>	<b>1108</b>	
<b>0Z27</b>	<b>1109</b>	
<b>0Z28</b>	<b>1110</b>	
<b>0Z29</b>	<b>1111</b>	
<b>0Z30</b>	<b>1112</b>	
<b>0Z31</b>	<b>1113</b>	

**FIGURE 2: INFORMATION DESCRIBED ON THE TAG**



**Please follow the steps outlined in the Service Manual (on MDL or MEDIC) for seatbelt replacement, if necessary.**

**MDL:** service > service tech resources > Service Related Items > Service & Owner's Publications > 2022 Model Year Outlander > Service Manual Data > Volume 1 > Interior Supplemental Restraint System Group 52 > Seat Belt > P.52B-22

**MEDIC:** TIR Menu > Model Year 2022 > Model Outlander > Model Outlander DG (2022-) > Service Manual > Seat Belt > Removal and Installation > Front Seat Belt **OR** Rear Seat Belt



**When using 2022 Service Manual, be sure to refer to Volume 1 first. There are duplicate sections in the service information in Volume 1 and in Volume 2 to 5. As for the duplicate sections of the service information, refer to only the service information in Volume 1.**



**Be sure to check precautions and notes by referring to PRECAUTIONS for SEAT BELT and Removal and Installation of FRONT SEAT BELT and REAR SEAT BELT before work.**

## PRECAUTION PRECAUTIONS

### Precaution for Supplemental Restraint System (SRS) "AIR BAG" and "SEAT BELT PRE-TENSIONER"

The Supplemental Restraint System such as "AIR BAG" and "SEAT BELT PRE-TENSIONER", used along with a front seat belt, helps to reduce the risk or severity of injury to the driver and front passenger for certain types of collision.

Information necessary to service the system safely is included in the "SRS AIR BAG" and "SEAT BELT" of this Service Manual.

#### **WARNING:**

*Always observe the following items for preventing accidental activation.*

- *To avoid rendering the SRS inoperative, which could increase the risk of personal injury or death in the event of a collision that would result in air bag inflation, it is recommended that all maintenance and repair be performed by an authorized Mitsubishi Motors dealer.*
- *Improper repair, including incorrect removal and installation of the SRS, can lead to personal injury caused by unintentional activation of the system. For removal of Spiral Cable and Air Bag Module, see "SRS AIR BAG".*
- *Never use electrical test equipment on any circuit related to the SRS unless instructed to in this Service Manual. SRS wiring harnesses can be identified by yellow and/or orange harnesses or harness connectors.*

### PRECAUTIONS WHEN USING POWER TOOLS (AIR OR ELECTRIC) AND HAMMERS

#### **WARNING:**

*Always observe the following items for preventing accidental activation.*

- *When working near the Air Bag Diagnosis Sensor Unit or other Air Bag System sensors with the ignition/power switch ON or engine running, never use air or electric power tools or strike near the sensor(s) with a hammer. Heavy vibration could activate the sensor(s) and deploy the air bag(s), possibly causing serious injury.*
- *When using air or electric power tools or hammers, always switch the ignition/power switch OFF, disconnect the 12V battery or batteries, and wait at least 3 minutes before performing any service.*

### Precautions for Removing Battery Terminal

- With the adoption of Auto ACC function, ACC power is automatically supplied by operating the Keyless operation key or remote keyless entry or by opening/closing the driver side door. In addition, ACC power is supplied even after the ignition switch is turned to the OFF position, i.e. ACC power is supplied for a certain fixed time.
- When disconnecting the 12V battery terminal, turn off the ACC power before disconnecting the 12V battery terminal, observing "How to disconnect 12V battery terminal" described below.

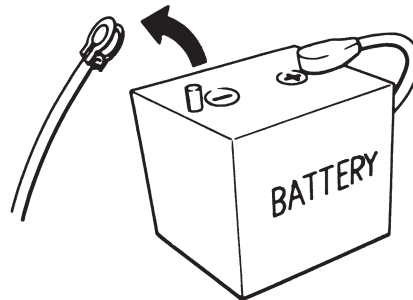

CF1009KEAA00USA

#### **NOTE:**

Some ECUs operate for a certain fixed time even after ignition switch is turned OFF and ignition power supply is stopped. If the battery terminal is disconnected before ECU stops, accidental DTC detection or ECU data damage may occur.

- For vehicles with the 2-batteries, be sure to connect the main battery and the sub battery before turning ON the ignition switch.

#### **NOTE:**

If the ignition switch is turned ON with any one of the terminals of main battery and sub battery disconnected, then DTC may be detected.

- After installing the 12V battery, always check "Self Diagnosis Result" of all ECUs and erase DTC.

#### **NOTE:**

The removal of 12V battery may cause a DTC detection error.

---

## HOW TO DISCONNECT 12V BATTERY TERMINAL

---

Disconnect 12V battery terminal according to instruction described below.

1. Open the hood.
2. Turn ignition switch to the ON position.
3. Turn ignition switch to the OFF position with the driver side door opened.
4. Get out of the vehicle and close the driver side door.
5. Wait at least 3 minutes.

### CAUTION:

While waiting, never operate the vehicle such as locking, opening, and closing doors. Violation of this caution results in the activation of ACC power supply according to the Auto ACC function.

6. Remove 12V battery terminal.

### CAUTION:

After installing 12V battery, always check self-diagnosis results of all ECUs and erase DTC.

## Precaution for Seat Belt Service

### CAUTION:

- Before removing the seat belt assembly, turn the ignition switch OFF, disconnect the battery negative terminal and wait at least 3 minutes.
- Never use electrical test equipment for seat belt connectors.
- After replacing or reinstalling seat belt assembly, or reconnecting seat belt connectors, check the system function. Refer to M.U.T.-III SE Function [DIAGNOSIS SYSTEM \(AIR BAG DIAGNOSIS SENSOR UNIT\)](#).
- Never use disassembled buckle or seat belt assembly.
- Replace anchor bolts if they are deformed or worn out.
- Never oil tongue and buckle.
- If any component of seat belt assembly is questionable, never repair. Replace the entire seat belt assembly.
- If webbing is cut, frayed or damaged, replace seat belt assembly.
- When replacing seat belt assembly, use a Mitsubishi Genuine seat belt assembly.

## REPAIR PROCEDURE

### SUPPLEMENTAL RESTRAINT SYSTEM (SRS) SEAT BELTS WITH PRE-TENSIONER

## SEAT BELTS WITH PRE-TENSIONER

### REMOVAL AND INSTALLATION

M15240041A0020

#### Pre-removal operation

Turn the ignition switch to the "LOCK" (OFF) position.

### <<FRONT SEAT BELTS>

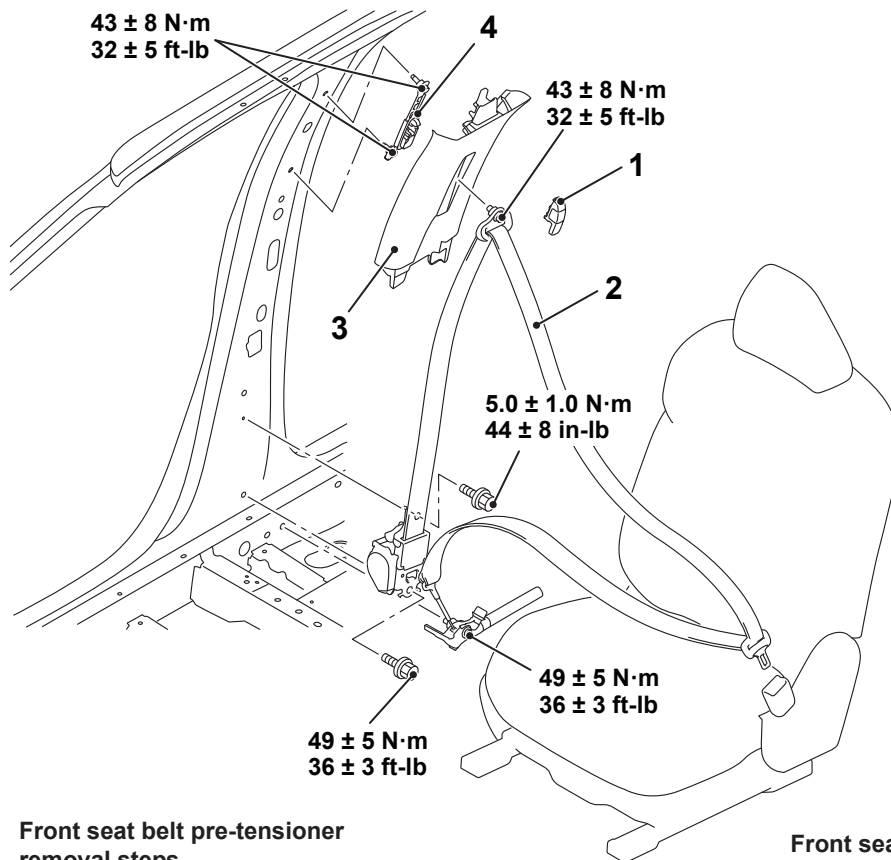

BCKA0564AA

#### Front seat belt pre-tensioner removal steps

- Disconnect the negative (-) battery terminal
  - Center pillar lower trim (Refer to GROUP 52A - Interior Trim P.52A-28).
- <<A>>
1. Front seat belt sash guide cover
  2. Front seat belt with pre-tensioner
  3. Center pillar upper trim (Refer to GROUP 52A - Interior Trim P.52A-28)
  4. Front seat belt anchor adjuster

#### Front seat belt pre-tensioner installation steps

- >>A<<
4. Front seat belt anchor adjuster
  3. Center pillar upper trim (Refer to GROUP 52A - Interior Trim P.52A-28)
2. Front seat belt with pre-tensioner
  1. Front seat belt sash guide cover
- Center pillar lower trim (Refer to GROUP 52A - Interior Trim P.52A-28).
  - Connect the negative (-) battery terminal
  - Check and clear all DTCs



## SUPPLEMENTAL RESTRAINT SYSTEM (SRS) SEAT BELTS WITH PRE-TENSIONER

### <SECOND SEAT BELTS>

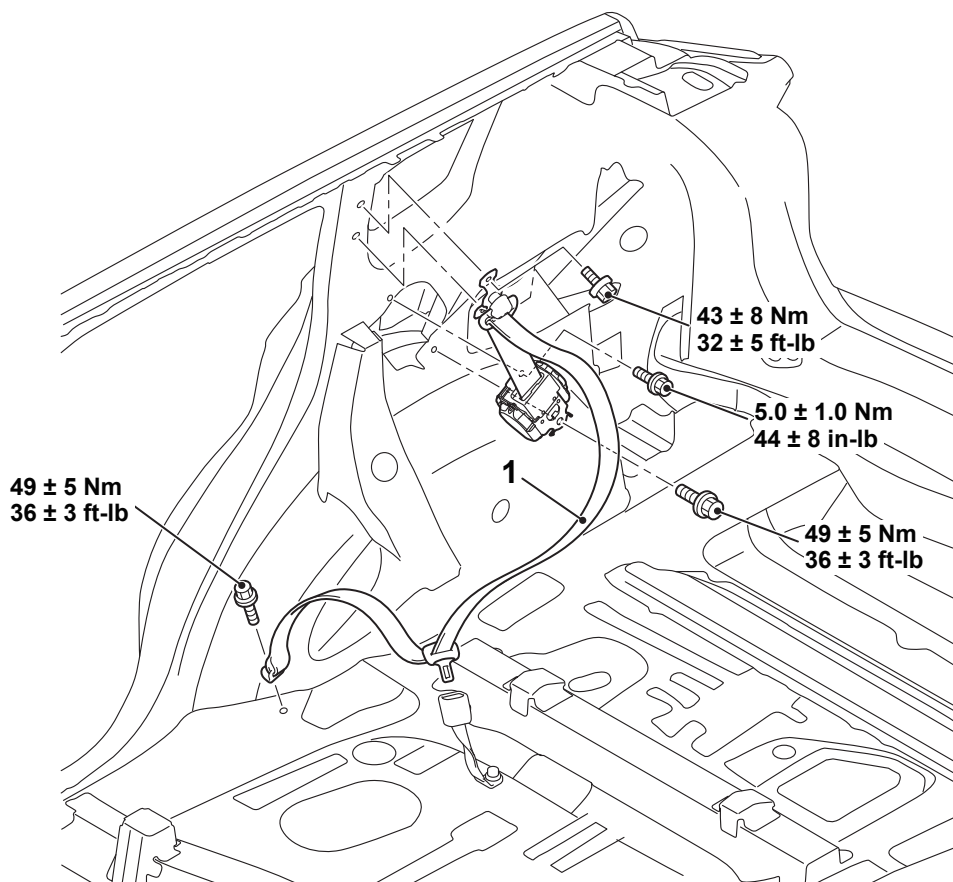

BCKA0583AA

#### Rear seat belt pre-tensioner removal steps

- Disconnect the negative (-) battery terminal.
- Quarter upper trim (Refer to GROUP 52A - Quarter Trim P.52A-28).

<<A>>

1. Rear seat belt with pre-tensioner

#### Rear seat belt pre-tensioner installation steps

- >A<<
1. Rear seat belt with pre-tensioner
    - Quarter upper trim (Refer to GROUP 52A - Quarter Trim P.52A-28).
    - Connect the negative (-) battery terminal.
    - Check and clear all DTCs

**SUPPLEMENTAL RESTRAINT SYSTEM (SRS)  
SEAT BELTS WITH PRE-TENSIONER**

**REMOVAL SERVICE POINT**

**<<A>> SEAT BELT PRE-TENSIONER REMOVAL**

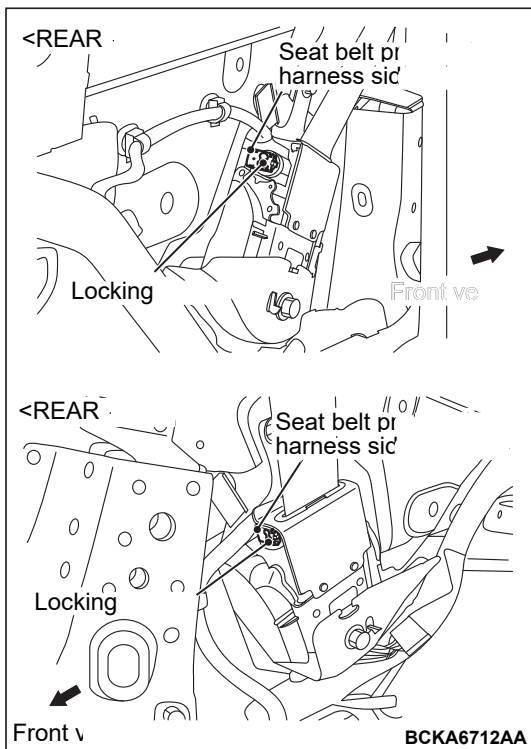
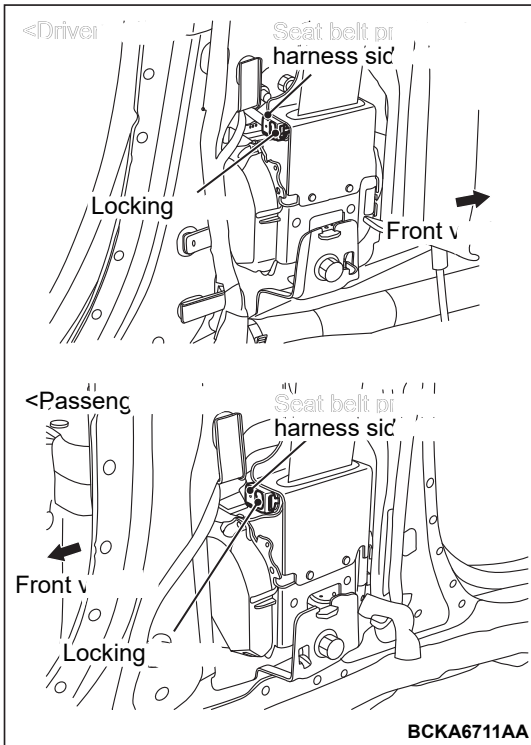

**CAUTION:**

Please use **EXTRA CAUTION** when removing the locking button on the seat belt pre-tensioner connector. The locking button should only be raised approximately 1mm in an upwards direction. This will release the yellow connector body that can now be gently pulled from the pre-tensioner.

**SUPPLEMENTAL RESTRAINT SYSTEM (SRS)  
SEAT BELTS WITH PRE-TENSIONER**

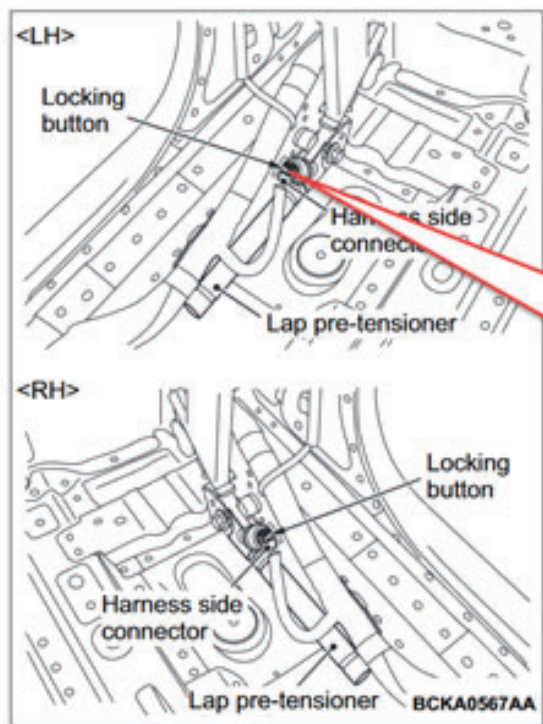

1. Use the flat-tipped screwdriver to pull out the locking button of wiring harness side connector, and release the lock.

**USE EXTREME CARE TO AVOID DAMAGE** when releasing the black locking button. **DO NOT ATTEMPT TO REMOVE COMPLETELY!** The locking button is only designed to be raised approximately 1mm which permits removal of the connector.

**INSTALLATION SERVICE POINT  
>>A<< SEAT BELT PRE-TENSIONER  
INSTALLATION**

Insert the claws of the seat belt retractor into the body, and install the seat belt retractor in order of the numbers shown in the figure.

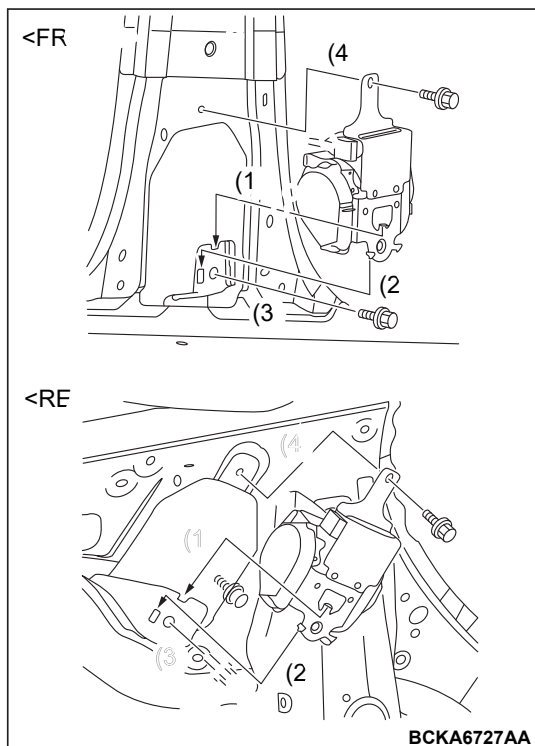

## SUPPLEMENTAL RESTRAINT SYSTEM (SRS) SEAT BELTS WITH PRE-TENSIONER

---

### INSPECTION

M15240042A0007

**⚠ DANGER**

***Never attempt to measure the circuit resistance of the seat belt pre-tensioner and lap pre-tensioner (squib), even if you are using the specified tester. If the circuit resistance is measured with a tester, accidental air bag deployment will result, and possible serious personal injury.***

**⚠ WARNING**

***If any component damage is found during the following inspection, replace the seat belt pre-tensioner with a new one.***

If any malfunction is found in the following inspections, replace the seat belt with pre-tensioner with a new one.

1. Check the seat belt pre-tensioner and lap pre-tensioner for dents, cracks or deformation.
2. Check the harness and connector for damage and the terminal for deformation.

**PARTS INFORMATION**

Use the genuine Mitsubishi Part listed below:

DESCRIPTION	PART NUMBER	QTY
SEAT BELT ASSY,OTR RH (FRONT)	86884W161P	1
SEAT BELT ASSY,OTR LH (REAR)	88845W131P	1
SEAT BELT ASSY,OTR RH (REAR)	88844W121P	1

**WARRANTY INFORMATION**

VEHICLES	CAMPAIGN OPERATION	LABOR TIME (HRS)	REPAIR DESCRIPTION
2022 OUTLANDER	C2108R01	0.2	INSPECT THE SEAT BELT LOT NUMBER ON THREE SEAT BELTS.
	C2108R02	1	INSPECT THE SEAT BELT LOT NUMBER ON THREE SEAT BELTS. AND REPLACE FRONT PASSENGER SEAT BELT ASSEMBLY.
	C2108R03	1.1	INSPECT THE SEAT BELT LOT NUMBER ON THREE SEAT BELTS AND REPLACE 2 <sup>ND</sup> ROW RIGHT OR LEFT SEAT BELT ASSEMBLY.
	C2108R04	1.4	INSPECT THE SEAT BELT LOT NUMBER ON THREE SEAT BELTS AND REPLACE TWO SEAT BELT ASSEMBLIES.
	C2108R05	1.7	INSPECT THE SEAT BELT LOT NUMBER ON THREE SEAT BELTS AND REPLACE THREE SEAT BELT ASSEMBLIES.

## WARRANTY / RECALL CAMPAIGN CLAIM INFORMATION

Enter all claims as claim type 'C' - Recall/Campaign Claims.

Please follow the campaign instructions when entering each claim. See the claim example provided below.

Certain 2022 MY Outlander

### RECALL CLAIM HEADER SECTION

The screenshot shows the 'Service Warranty Warranty Claim' interface. The 'Campaign Information' section contains the following fields:

Campaign Operation No	C2108R	Enter As	<input type="checkbox"/>	TCP
Miles/Km	64500	Check the Open Campaign area of the Superscreen each time to be certain of a vehicle's eligibility. Only VINs showing C2108R as open are involved.		
VIN	JA.....			

Below the campaign information, there are fields for 'Service Technician' and 'Service Advisor', each with an 'Emp No' dropdown menu. A 'Spec Value \*' field and a 'Duplicate Recall \*' checkbox are also present.

At the bottom, there are fields for 'Dealer: 99320', 'Ref No:', 'VIN:', 'Claim No:', 'Adj:', 'Claim Status: Incomplete', and 'Model and Year:'. Two buttons, 'Save & Continue' and 'Main Menu', are highlighted with blue boxes.

After entering the required customer data, vehicle information, selecting the applicable repair campaign and scenario performed (please note there are only 5 possible repair scenarios for this campaign), and then clicking the "Save and Continue" button, the system will automatically fill-in several fields

**MITSUBISHI MOTORS NORTH AMERICA, INC.**  
PO Box 689040  
Franklin, TN 37068



## IMPORTANT SAFETY RECALL

This notice applies to your vehicle, \_\_\_\_\_.

Date: September 2021

Dear FIRSTNAME LASTNAME,

This notice is sent to you in accordance with the National Traffic and Motor Vehicle Safety Act.

**Reason for notice:** Mitsubishi Motors North America, Inc. (MMNA) has decided that a defect which relates to motor vehicle safety exists in certain 2022 Outlander vehicles. The Automatic Locking Retractor (ALR) function of the subject seat belt assemblies may deactivate before the webbing is fully retracted due to dimensionally out of tolerance ALR levers. This condition, if it exists, does not comply with Federal Motor Vehicle Safety Standard (FMVSS) 208. If the ALR function deactivates while an affected seat belt is used to secure a child restraint seat, the child restraint seat may not be tightly secured, which increases risk of serious injury or death.

**What you should do:** Please contact your local Mitsubishi Motors dealer and schedule an appointment to have the affected seat belt(s) inspected and replaced, if necessary, free of charge. When you bring your vehicle in, please show the dealer this letter. If you misplace this letter, the dealer will still perform this repair for your vehicle, free of charge.

**What your dealer will do:** The dealership will inspect the lot number on the passenger front and two outboard (left and right) 2<sup>nd</sup> row seatbelts and replace the seatbelt(s), if necessary.

**How long will it take?** The time needed for the inspection is approximately **12 minutes**. The time needed for seat belt replacement, if necessary, is approximately **1 hour and 42 minutes**. The dealer may need your vehicle for a longer period of time, but every effort will be made to minimize your inconvenience.

If you experience any problem having your vehicle repaired promptly and/or at no charge, please inform us by calling the Mitsubishi Customer Relations Department at **888-648-7820**. Hours: Monday through Friday 7 a.m. to 4 p.m. (Central Time)

If, after contacting Mitsubishi Customer Relations, you still have a problem getting this repair made promptly and/or without charge, you may submit a complaint to the Administrator, National Highway Traffic Safety Administration, 1200 New Jersey Avenue SE, Washington, D.C. 20590, or call the toll-free Vehicle Safety Hotline at 1-888-327-4236 (TTY: 1-800-424-9153), or go to <http://www.safercar.gov>.

If you have already encountered a problem with the passenger front or two outboard (left and right) 2<sup>nd</sup> row seatbelts and had them replaced as a result of this specific condition and have paid for the repair, you may send your original repair order or invoice, **and** original receipt/proof of payment to the following address for reimbursement consideration:

Mitsubishi Motors North America Inc., Customer Relations, P.O. Box 689040, Franklin, TN 37068

**If you are the lessor of this vehicle**, please forward a copy of this notice to the lessee within ten days to comply with federal regulations.

We appreciate your prompt attention to this matter.

Sincerely,

Mitsubishi Motors North America, Inc.

C2108R