

Classification:

FA21-008

Reference:

ITB21-018

COPYRIGHT© NISSAN NORTH AMERICA, INC.

Date:

July 6, 2021

VOLUNTARY SAFETY RECALL CAMPAIGN 2021 QX50; KNUCKLE INSPECTION

CAMPAIGN ID #: R21A5
APPLIED VEHICLE: 2021 QX50 (J55)

Check Service COMM or Dealer Business Systems (DBS)
National Service History to confirm campaign eligibility.

INTRODUCTION

Infiniti is conducting this voluntary safety recall campaign on certain specific model year 2021 QX50 vehicles to inspect and, if necessary, replace the front steering knuckles and rear suspension knuckles. This service will be performed at no charge to the client for parts or labor.

IDENTIFICATION NUMBER

Infiniti has assigned identification number R21A5 to this campaign. This number must appear on all communication and documentation of any nature dealing with this campaign.

RETAILER RESPONSIBILITY

It is the retailer's responsibility to check Service COMM or Dealer Business Systems (DBS) National Service History for the campaign status on each vehicle falling within the range of this voluntary safety recall which for any reason enters the service department. This includes vehicles purchased from private parties or presented by transient (tourist) owners and vehicles in a retailer's inventory. **Federal law requires that new vehicles in retailer inventory which are the subject of a safety recall must be corrected prior to sale. Failure to do so can result in civil penalties by the National Highway Traffic Safety Administration.** While federal law applies only to new vehicles, Infiniti strongly encourages retailers to correct any used vehicles in their inventory before they are retailed.

Infiniti Bulletins are intended for use by qualified technicians, not 'do-it-yourselfers'. Qualified technicians are properly trained individuals who have the equipment, tools, safety instruction, and know-how to do a job properly and safely. **NOTE:** If you believe that a described condition may apply to a particular vehicle, DO NOT assume that it does. See your Infiniti retailer to determine if this applies to your vehicle.

SERVICE PROCEDURE

⚠ WARNING To avoid the risk of death or severe personal injury, do not reuse single use parts noted in this TSB. Reusing a single use part may induce risk that it, or the component that it secures, may become loose.

Remove The Front Knuckle

1. Place the vehicle on a lift and raise to a suitable height.
2. Remove both front wheel and tire assemblies.
3. Remove the front wheel speed sensor bolt (10 mm) from the steering knuckle (Figure 1).
4. Remove the front wheel speed sensor harness bracket bolt (10 mm) from the steering knuckle.

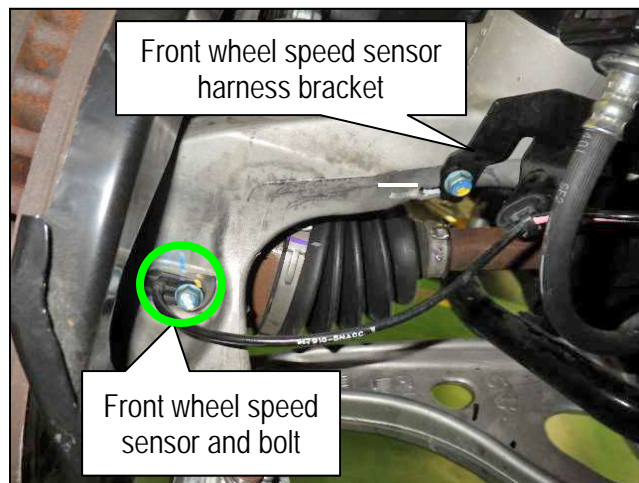

Figure 1

5. Separate the front wheel speed sensor harness grommets from the front wheel speed sensor harness bracket (Figure 2).
6. Separate the front wheel speed sensor from the steering knuckle.



Figure 2

7. Remove the stabilizer bar connecting rod nut (18 mm), as shown in Figure 3.



Figure 3

8. Separate the stabilizer bar connecting rod from the strut bracket, as shown in Figure 4.

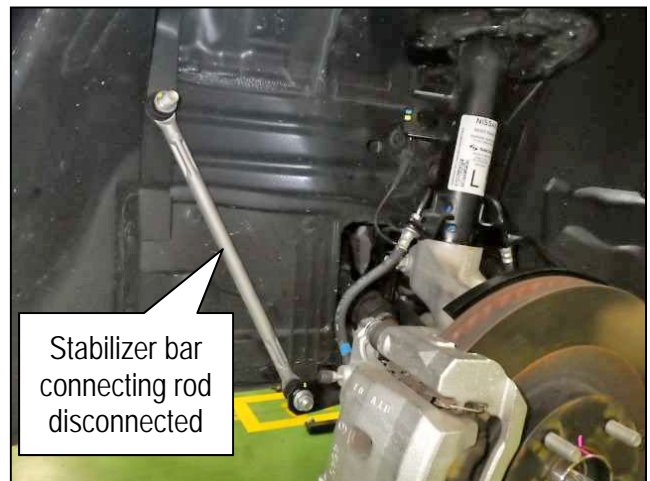

Figure 4

9. Remove the front brake caliper assembly as follows:
 - a. Place alignment marks on the disc brake rotor and on the wheel hub.

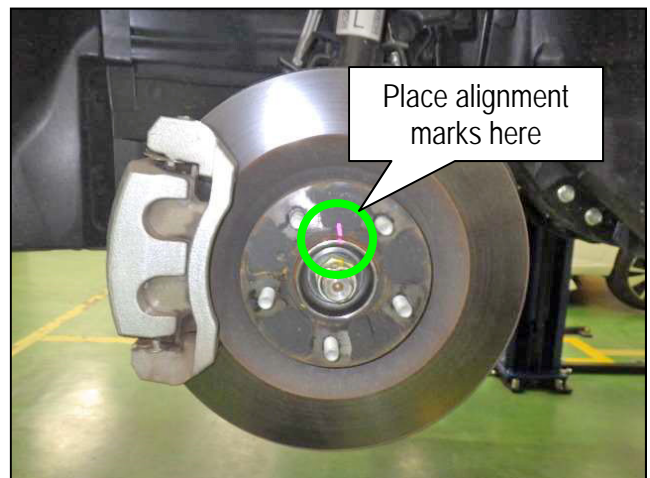

Figure 5

- b. Remove the front brake hose lock plates from the strut.

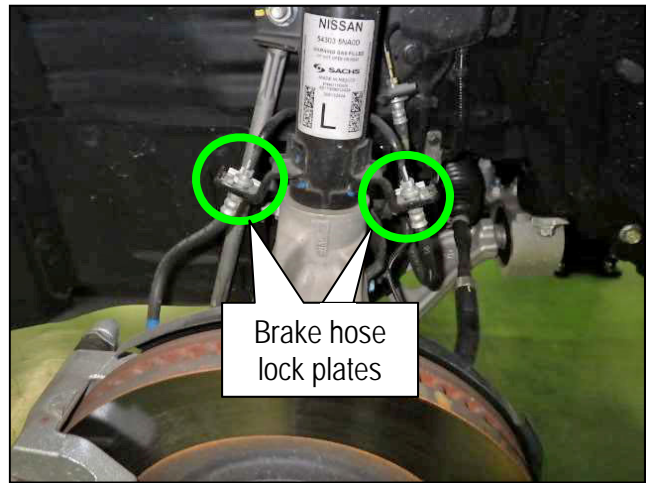

Figure 6

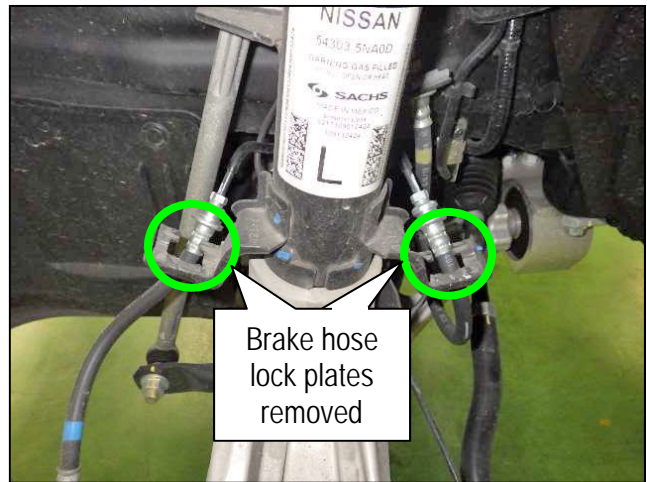

Figure 7

- c. Remove the 2 front brake caliper assembly bolts (22 mm).

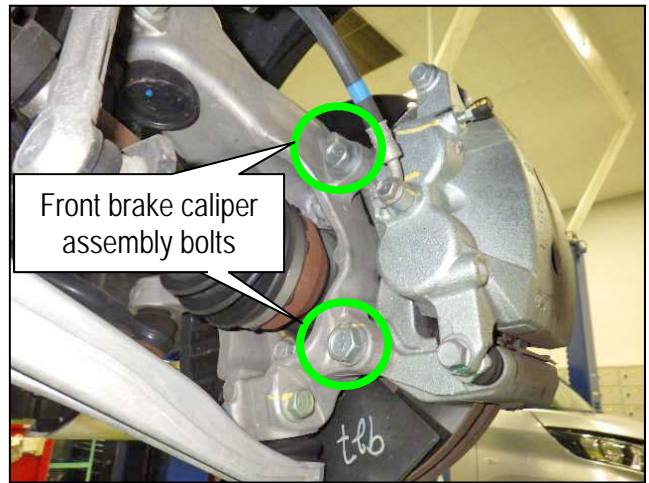

Figure 8

- d. Separate the front brake caliper assembly from the steering knuckle.



Figure 9

- 10. Remove the front disc brake rotor

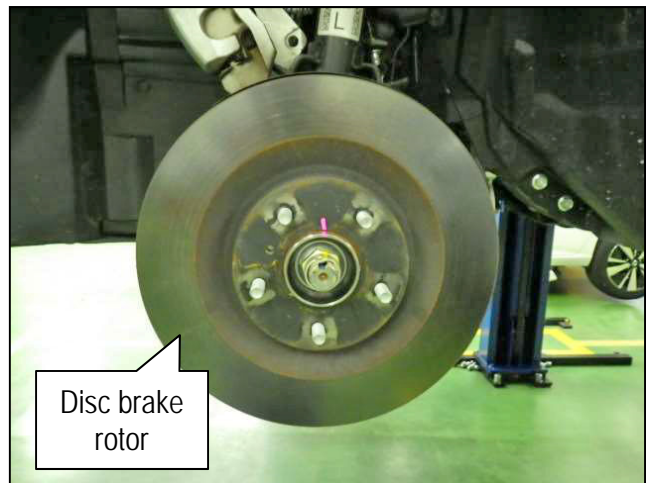

Figure 10

11. Remove the wheel hub lock nut (32 mm) from the drive shaft as follows:
 - a. Using a suitable tool such as a Lock Nut Cape Chisel (J-52982), release the staked area of the wheel hub lock nut.

NOTICE

To avoid damage to the drive shaft threads, verify the staked area of the wheel hub lock nut is completely released from the drive shaft.

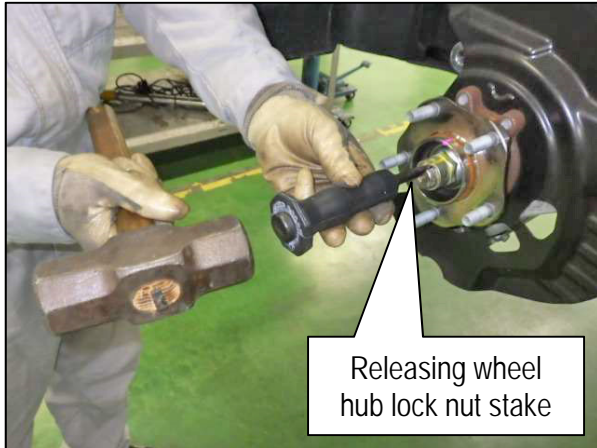

Figure 11



Figure 12

NOTICE

To avoid damage to the drive shaft threads, loosen the wheel hub lock nut until the front face of the nut is even with the face of the drive shaft.

- b. Loosen but do not remove the wheel hub lock nut (32 mm) from the drive shaft.
- c. Using a piece of wood and suitable tool, tap on the wheel hub lock nut to disengage the drive shaft from the wheel hub.

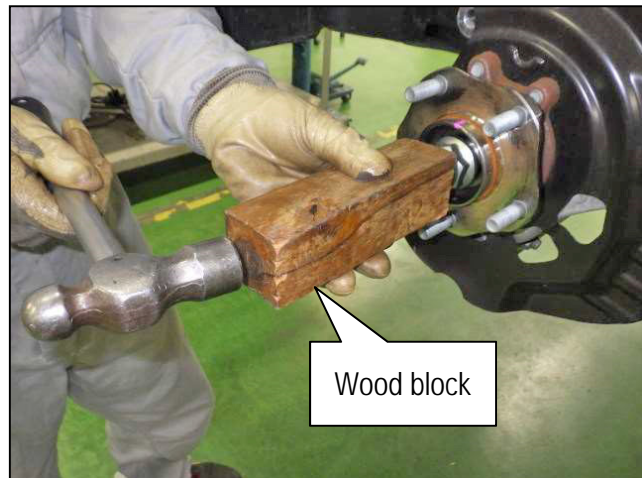

Figure 13

- d. Once the drive shaft is disengaged from the wheel hub, remove the wheel hub lock nut.
 - Do not reuse the nut.



Figure 14

12. Remove the front knuckle as follows:
- Remove the cotter pin.
 - Do not reuse the cotter pin.
 - Remove the outer socket nut (18 mm) from the front knuckle.
 - Separate the steering outer socket from the front knuckle.



Figure 15



Figure 16

- Remove the transverse link nut, (18 mm) and bolt (18 mm) from the front knuckle.
 - Do not reuse the nut.



Figure 17

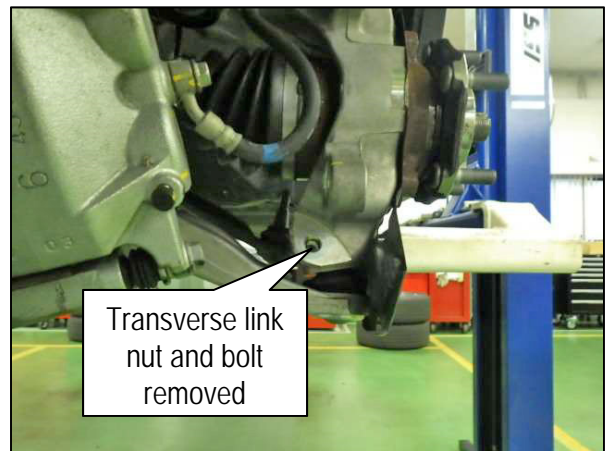

Figure 18

- e. Cover the transverse link joint with a shop cloth.

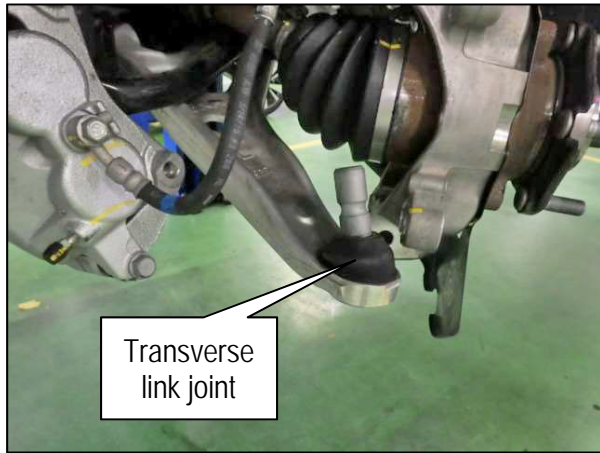

Figure 19



Figure 20

- f. Separate the drive shaft from the wheel hub.



Figure 21

- g. Put alignment marks on the front strut mount insulator.
- h. Remove the 3 front strut bolts (16 mm).
- i. Remove the front strut and front knuckle as an assembly.

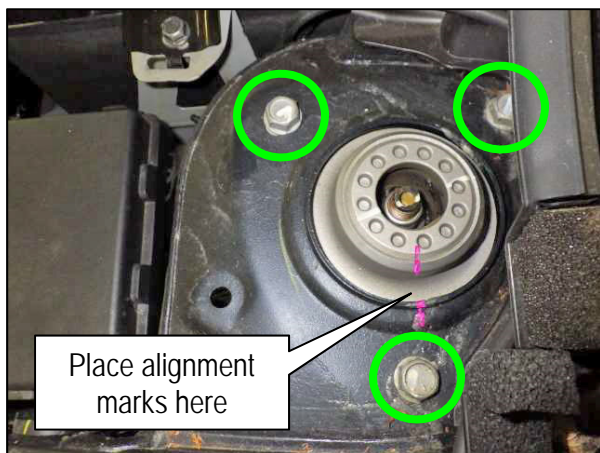

Figure 22

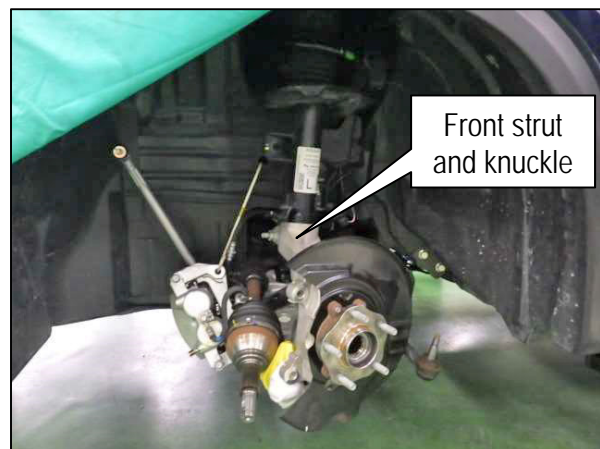

Figure 23

- 13. Repeat steps 6 - 11 on pages 2 - 8 for the opposite side of the vehicle, and then proceed to step 13 on page 9.

Disassemble The Front Knuckle

14. Place the front knuckle securely in a vise.

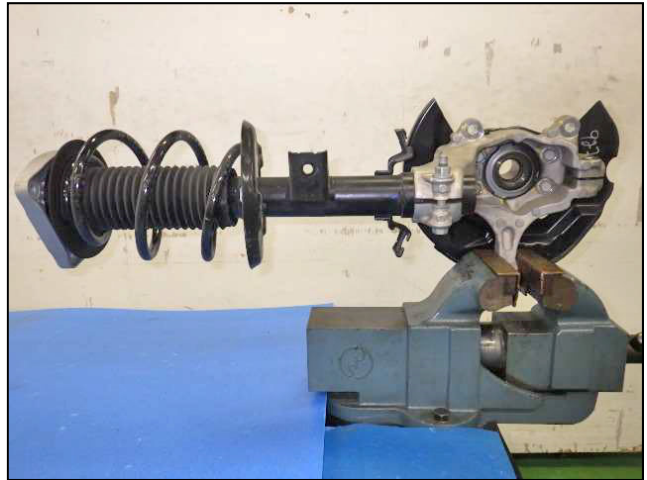

Figure 24

15. Remove the 4 wheel hub bolts (17 mm) from the front knuckle.

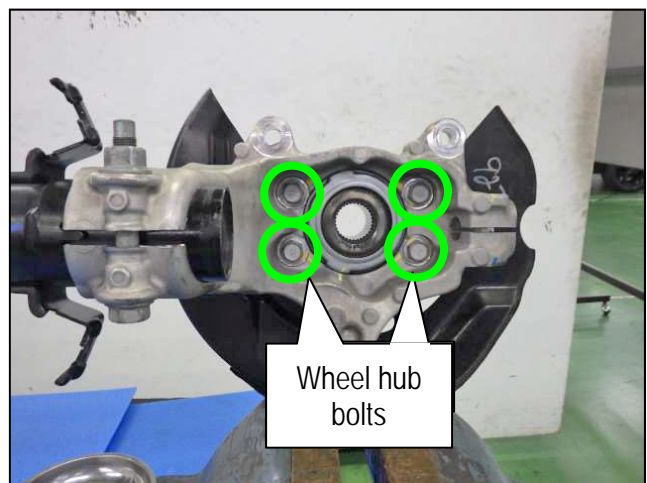

Figure 25

16. Separate the wheel hub and splash guard from the front knuckle.



Figure 26



Figure 27

17. Repeat steps 13 - 15 for the opposite side of the vehicle, and then proceed to step 17 on page 10.

Confirm the Front Knuckle Casting Stamp Date

The following Service Procedure uses an online form that must be filled out while performing the procedure.

18. Locate the casting stamp dates on each suspension knuckle, where indicated in Figure 28.

EXAMPLE:

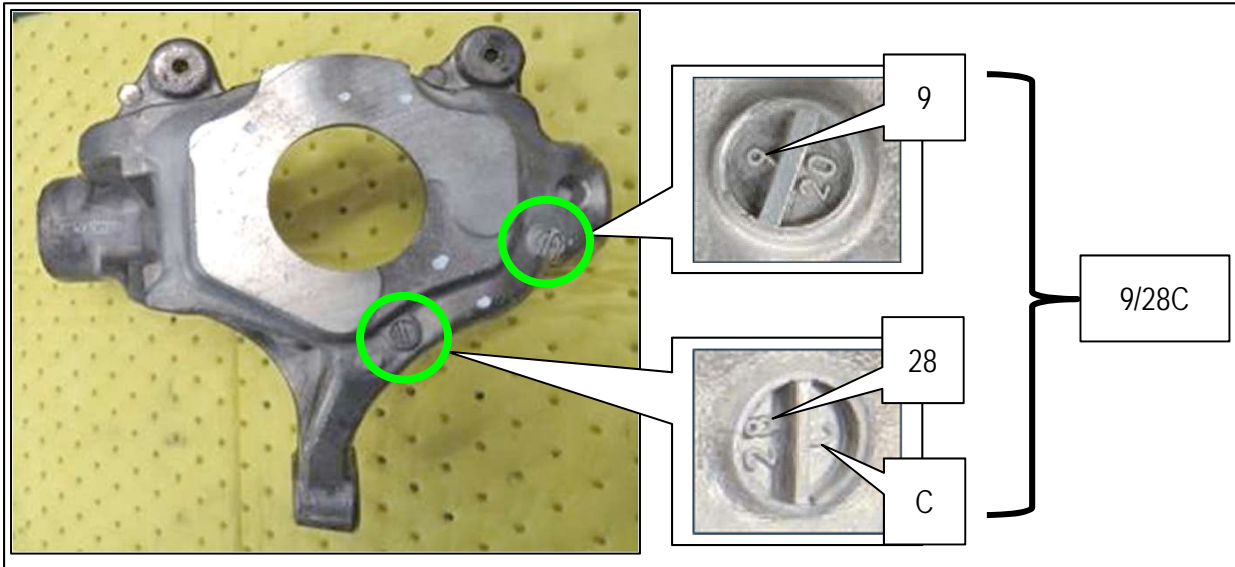

Figure 28

19. Open the ASIST form found at **ASIST > Tech Support Info > Bulletin Support Items > R21A5 Knuckle Inspection** (see Figure 29 and Figure 30).

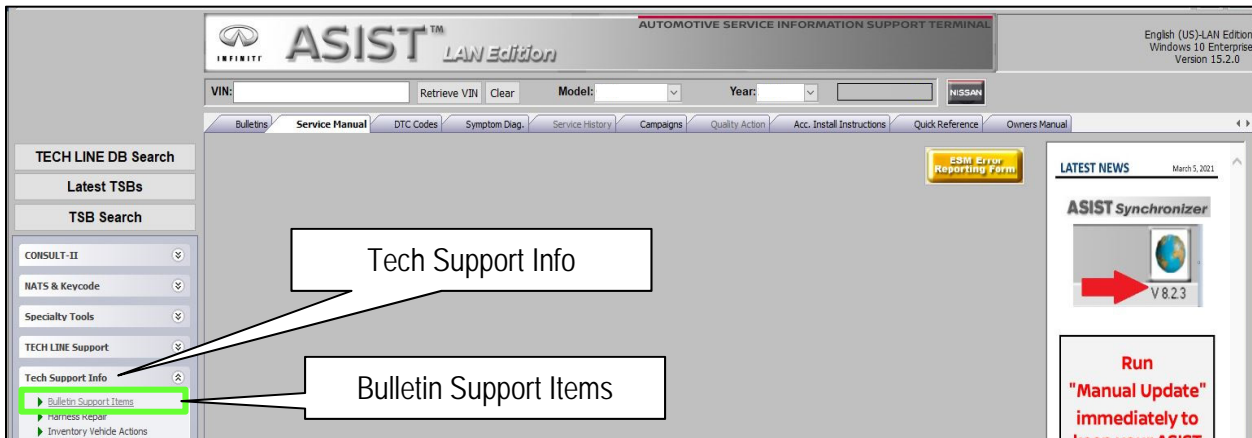

Figure 29

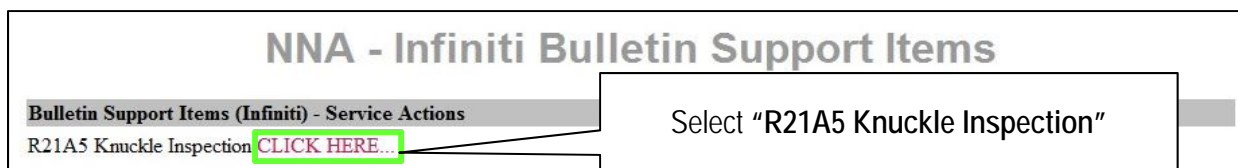

Figure 30

20. Enter the vehicle VIN and both casting stamp dates into the ASIST form, and then select **Submit** (Figure 31).

- If the ASIST inspection result is **OK** (Figure 31), print the Knuckle Inspection form and attach it to the work order. Skip to step 24 on page 14 to **reassemble** the original suspension knuckles.
- If the ASIST inspection result is **NG** (Figure 32), print the Knuckle Inspection form and attach it to the work order. Place a parts order in DBS for the part number shown at the bottom of the Knuckle Inspection form, and proceed to step 20 on page 12 to **replace** the affected suspension knuckle(s).

R21A5 Knuckle Inspection
6/1/2021 1:09:14 PM (Mountain Standard Time)

Model

Input 17 digit VIN

Input Front Steering Knuckle Casting code

LH	<input type="text" value="7/22c"/>
RH	<input type="text" value="7/20a"/>

Input Rear Knuckle Casting code

LH	<input type="text" value="7/3A"/>
RH	<input type="text" value="7/3a"/>



Inspection is OK, Reassemble the vehicle and submit a Warranty Claim

Figure 31

R21A5 Knuckle Inspection
6/1/2021 1:08:40 PM (Mountain Standard Time)

Model

Input 17 digit VIN

Input Front Steering Knuckle Casting code

LH	<input type="text" value="8/22c"/>
RH	<input type="text" value="7/20a"/>

Input Rear Knuckle Casting code

LH	<input type="text" value="7/3A"/>
RH	<input type="text" value="7/3a"/>

NG- Replace the FRONT xx knuckle using part number xxxxx-5NA0A . Print this page and attach to work order.

Figure 32

Replace The Front Knuckle

21. Place the front knuckle securely in a vise, if not already done so.
22. Separate the front strut from the front knuckle as follows:
 - a. Remove the front strut nut (18 mm) and bolt (18 mm).
 - Do not reuse the nut.

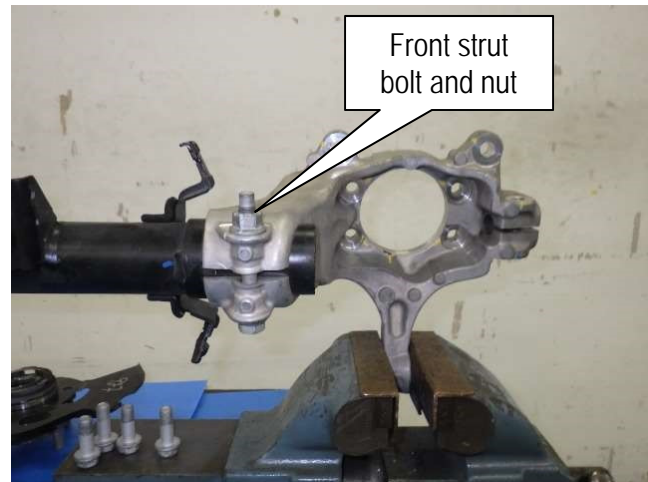

Figure 33

- b. Enlarge the gap of the front knuckle with a chisel.

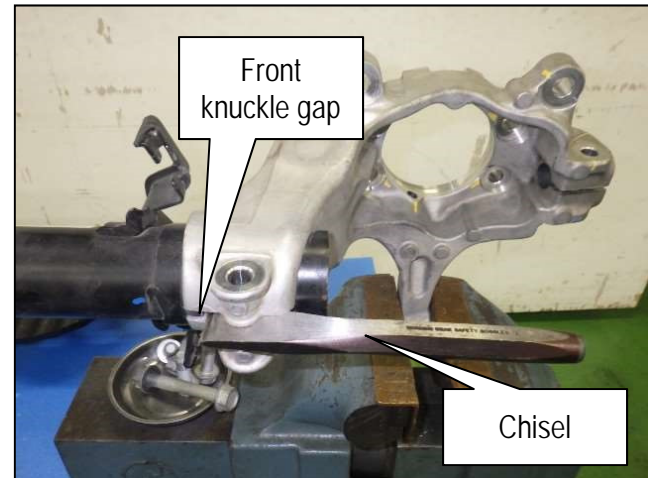

Figure 34

- c. Separate the front knuckle from the front strut.

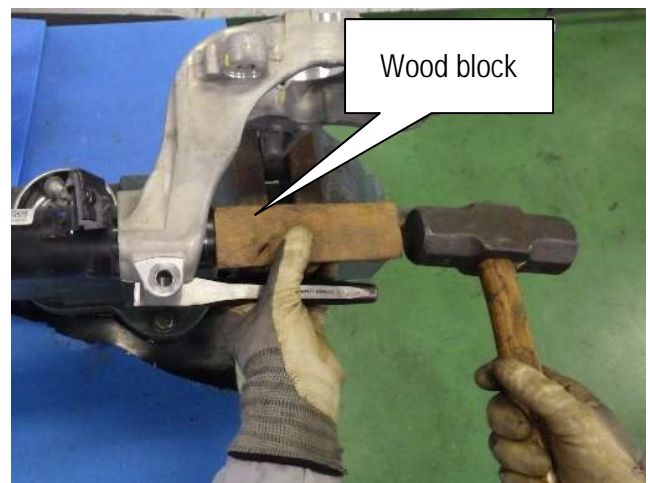

Figure 35

23. Install the strut to the new front knuckle as follows:
- a. Secure the new front knuckle in a vise.
 - b. Enlarge the gap of the new front knuckle with a chisel.
 - c. Clean the strut.

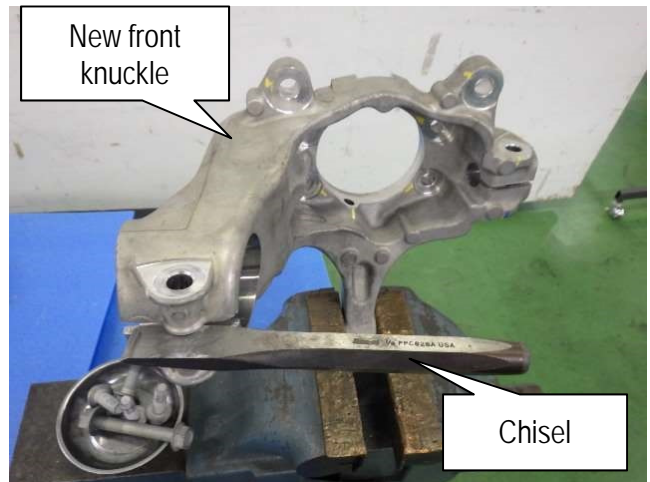

Figure 36

- d. Align the gap of the front knuckle to the projection part of the strut.



Figure 37

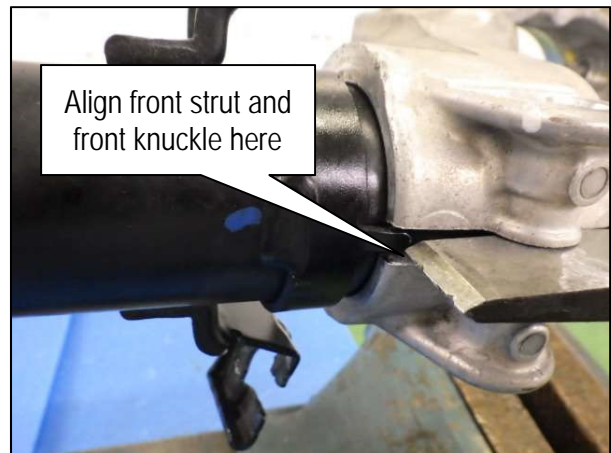

Figure 38

- e. Using a wood block, carefully drive the strut until the strut contacts the front knuckle stopper bracket end face.
- f. Remove the chisel from the front knuckle.

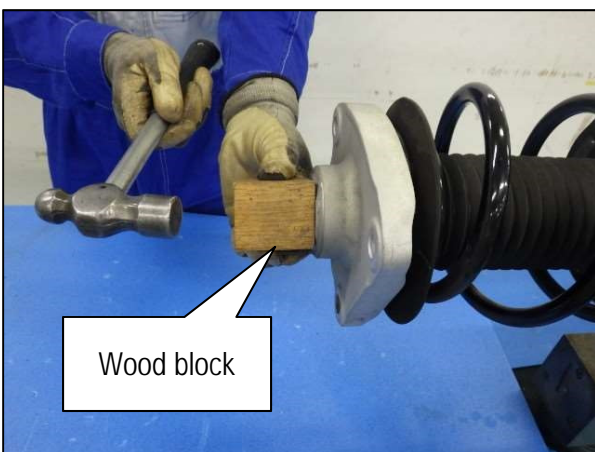

Figure 39

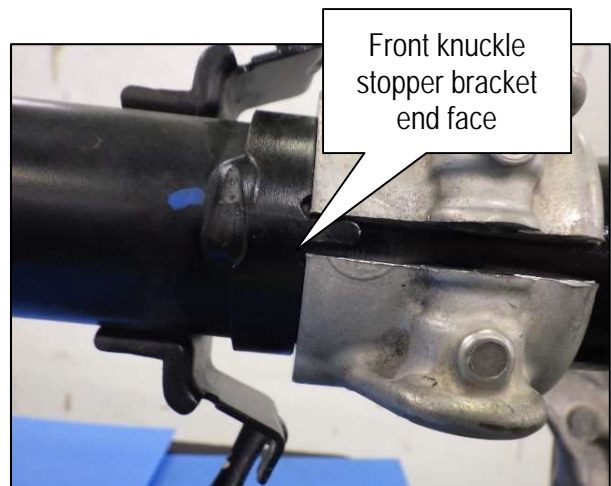

Figure 40

- g. Install the front strut bolt (18 mm) using a **new** front strut nut (18 mm).
- h. Tighten the new front strut nut (18mm) to 110.0 N•m (11.0 kg-m, **81 ft-lbs**).

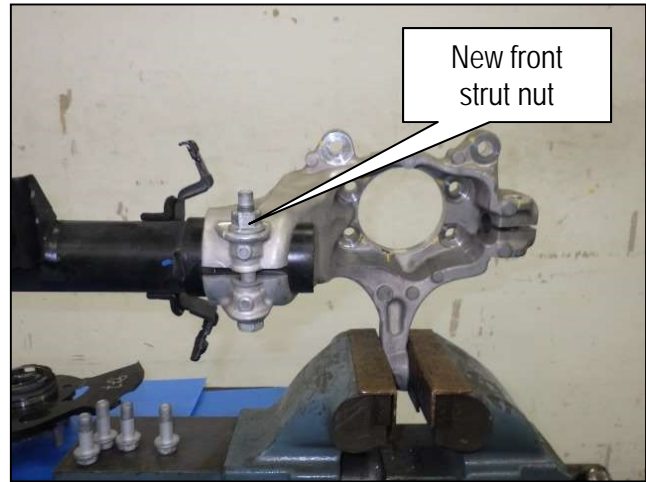

Figure 41

- 24. Repeat steps 20 - 22 on pages 12 - 14 for any ASIST inspection results that were **NG**, and then proceed to step 24.

Reassemble The Front Knuckle

- 25. Install the splash shield and the wheel hub to the front knuckle as follows:
 - a. Clean the splash shield and the wheel hub.
 - b. With the knuckle securely in a vise, place the splash shield and the wheel hub onto the front knuckle.
 - c. Install and hand tighten the 4 wheel hub bolts (17 mm).
 - d. Tighten the 4 wheel hub bolts (17 mm) to 88.3 N•m (9.0 kg-m, **65 ft-lbs**).

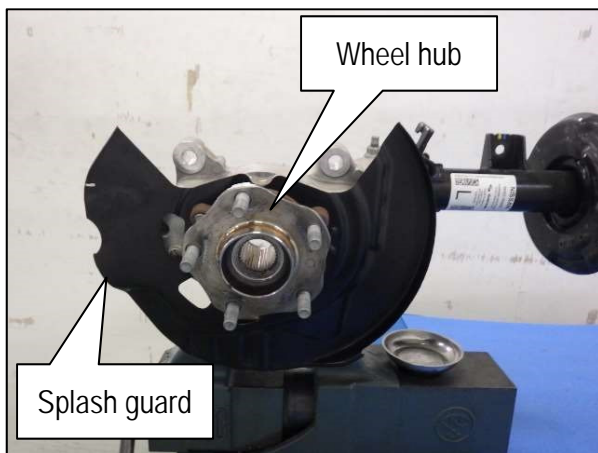

Figure 42

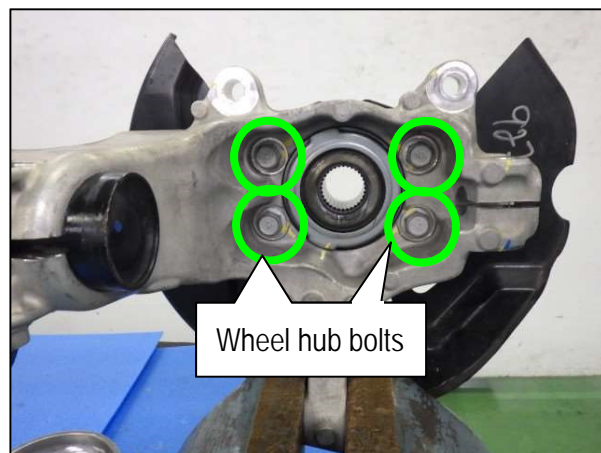

Figure 43

- 26. Repeat step 24 for the opposite side of the vehicle, and then proceed to step 26 on page 15.

Install The Front Knuckle

27. Install the front knuckle to the vehicle as follows:
 - a. Clean the matching area of the wheel hub and the drive shaft.
 - b. Coat the entire flat surface of the drive shaft matching area with Molykote M77 (PN: 44003-7S000).

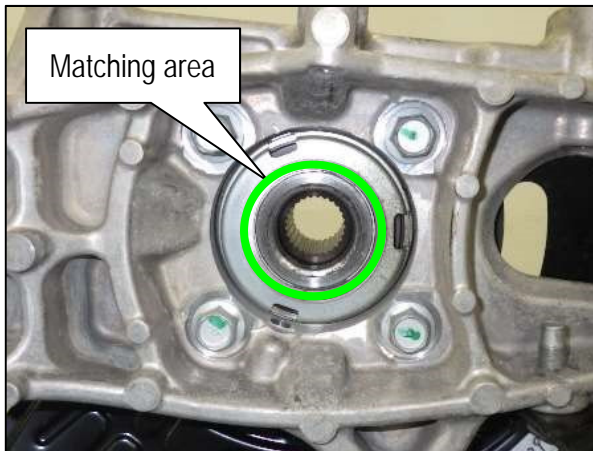

Figure 44

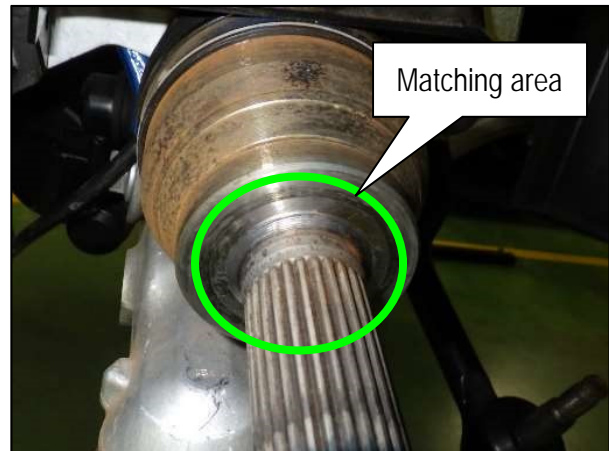

Figure 45

- c. Align and set the front strut mounting insulator to the alignment marks made previously.
 - d. Tighten the 3 front strut mounting insulator bolts (13 mm) to 50.0 N•m (5.1 kg-m, 37 ft-lbs).

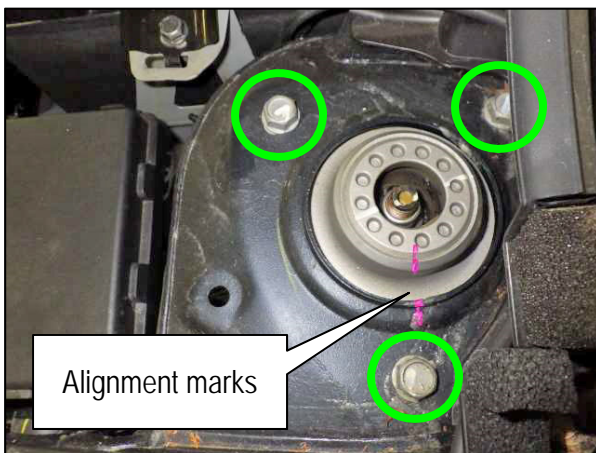

Figure 46



Figure 47

- e. Insert the drive shaft into the wheel hub.

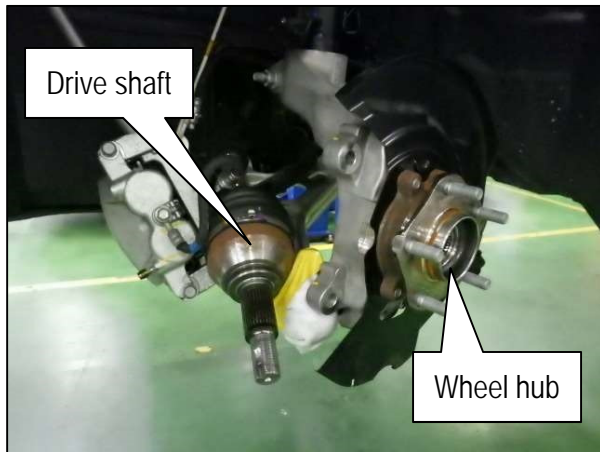

Figure 48



Figure 49

- f. Remove the shop cloth from the transverse link joint (Figure 49).
g. Insert the joint of the transverse link into the front knuckle.

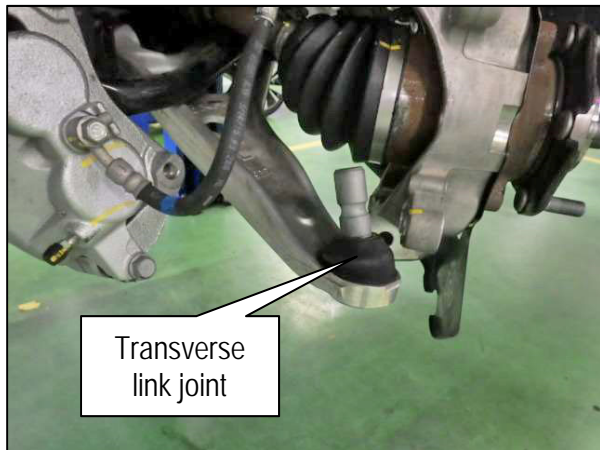

Figure 50

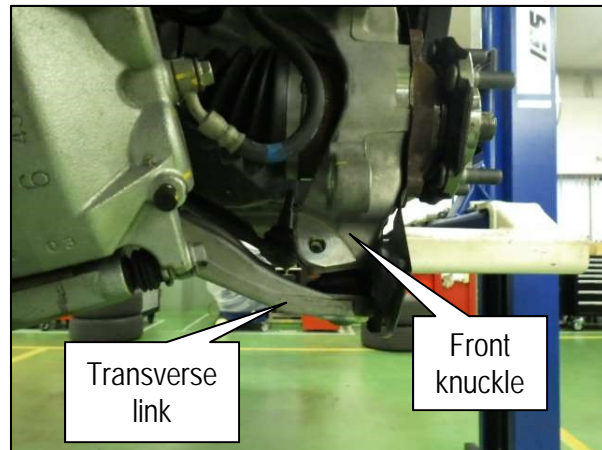

Figure 51

- h. Install the transverse link bolt (18 mm) using a **new** nut (18 mm).
i. Tighten the transverse link nut (18 mm) to 97.5 N·m (9.9 kg-m, 72 ft-lbs).



Figure 52

- j. Install the outer socket into the front knuckle using a **new** nut (18 mm).
- k. Tighten the outer socket nut (18 mm) to 76.0 N•m (7.8 kg-m, **56 ft-lbs**).
- l. Install a **new** cotter pin to the outer socket.

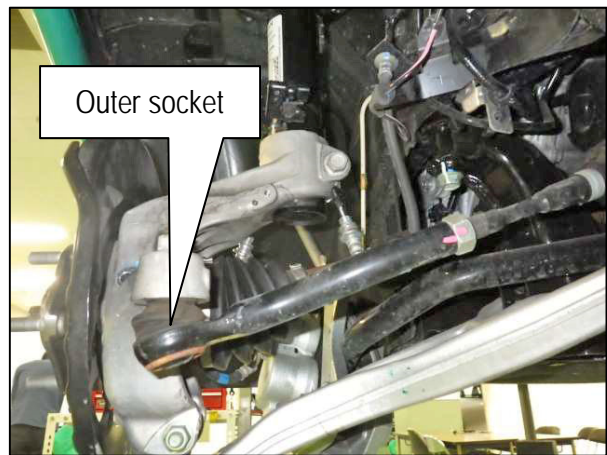

Figure 53

28. Install the front brake caliper assembly to the front knuckle as follows:
- a. Set the front disc brake rotor using the alignment marks.
 - b. Use a wheel nut to secure the front disc brake rotor.

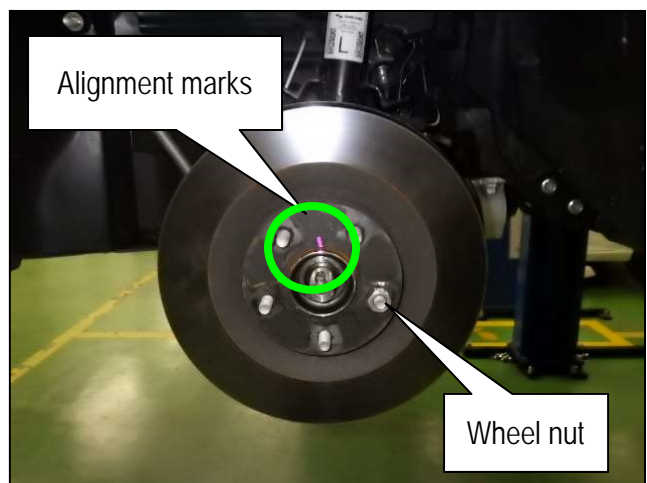

Figure 54

- c. Install the front brake caliper using the 2 existing bolts (22 mm).
- d. Tighten the front brake caliper bolts (22 mm) to 144.5 N•m (15.0 kg-m, **107 ft-lbs**).

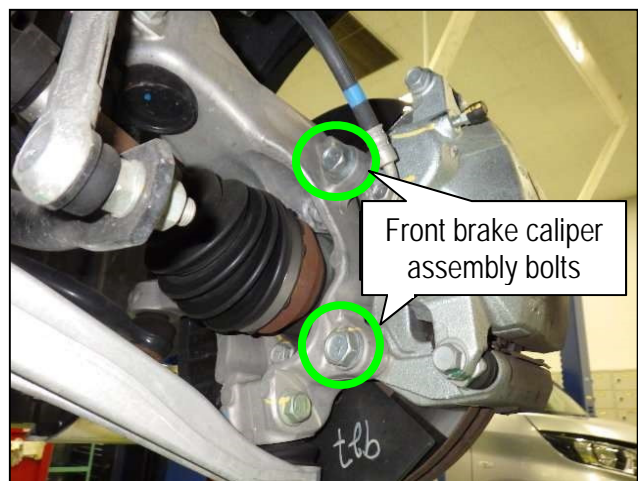

Figure 55

- e. Install the front brake hose with lock plates to the front strut.

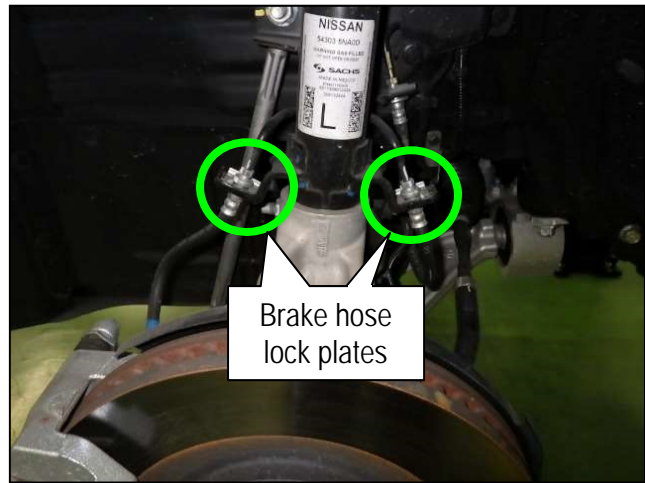

Figure 56

- 29. Install the front wheel speed sensor as follows:
 - a. Install the front wheel speed sensor and bolt (10 mm) to the front knuckle.
 - b. Tighten the wheel speed sensor bolt to 9.0 N•m (0.9 kg-m, 80 inch-lbs).
 - c. Install the front wheel speed sensor harness bracket and bolt (10 mm) to the front knuckle.
 - d. Tighten the front wheel speed sensor harness bracket bolt to 17.0 N•m (1.7 kg-m, 150 inch-lbs).

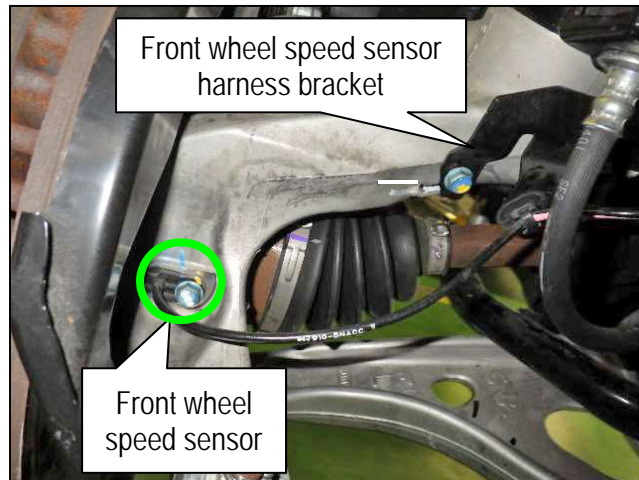

Figure 57

- 30. Install the stabilizer bar connecting rod and nut (18 mm).
 - a. Tighten the stabilizer bar connecting rod nut (18 mm) to 67.0 N•m (6.8 kg-m, 49 ft-lbs).



Figure 58

31. Install a **new** wheel hub lock nut as follows:

- a. Install the new wheel hub lock nut (32 mm) to the drive shaft.
- b. Tighten the wheel hub lock nut (32 mm) to 110.0 N•m (11.0 kg-m, **81 ft-lbs**).



Figure 59

- c. Using a hammer and chisel, stake the wheel hub lock nut to the drive shaft.
- d. Remove any wheel nuts securing the front disc brake rotor.

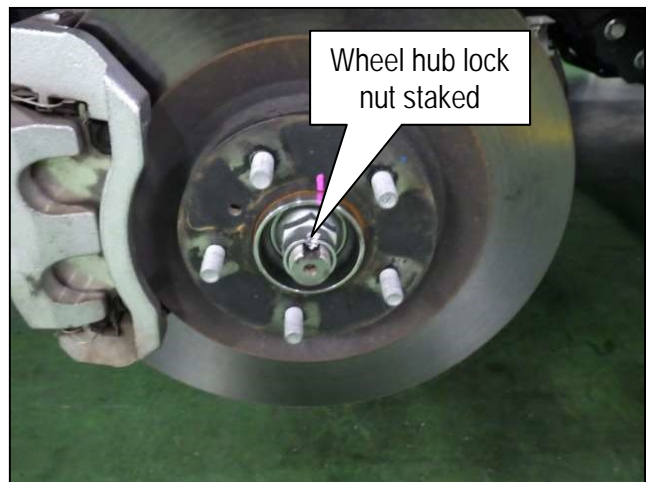

Figure 60

32. Repeat steps 26 - 30 on pages 15 - 19 for the opposite side of the vehicle, and then proceed to step 32.

33. Install both front wheel and tire assemblies.

- Tighten the wheel nuts to 113.0 N•m (12.0 kg-m, **83 ft-lbs**).

Remove The Rear Knuckle

34. Remove both rear wheel and tire assemblies.

35. Remove the rear wheel speed sensor bolt, wheel speed sensor, wheel speed sensor harness bracket bolt, and the wheel speed sensor harness bracket from the rear knuckle.

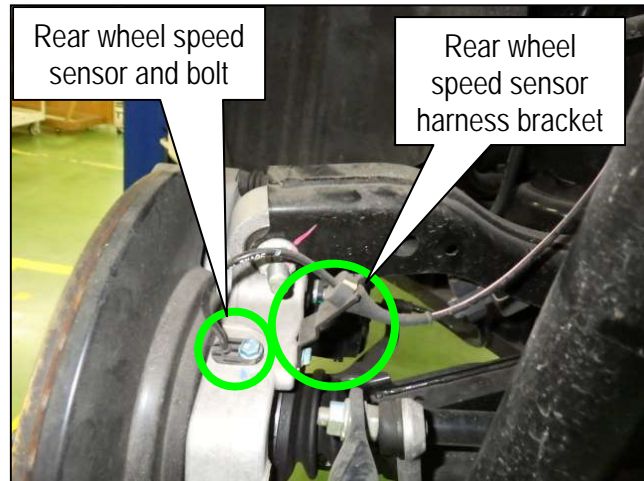

Figure 61

36. Position the wheel speed sensor and harness out of the way of the rear knuckle.

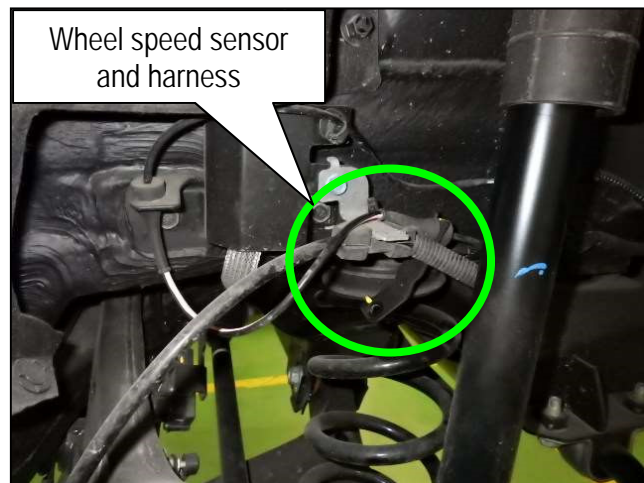

Figure 62

37. Place an alignment mark on the brake rotor and on the wheel hub.

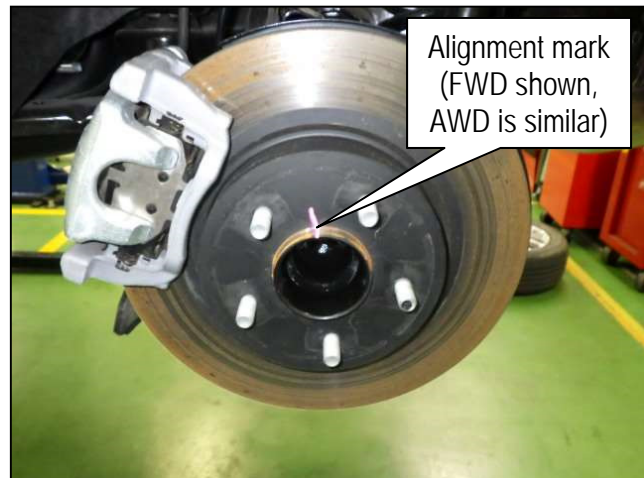

Figure 63

38. Remove the 2 electric parking brake harness bracket bolts and then remove the bracket from the rear knuckle.

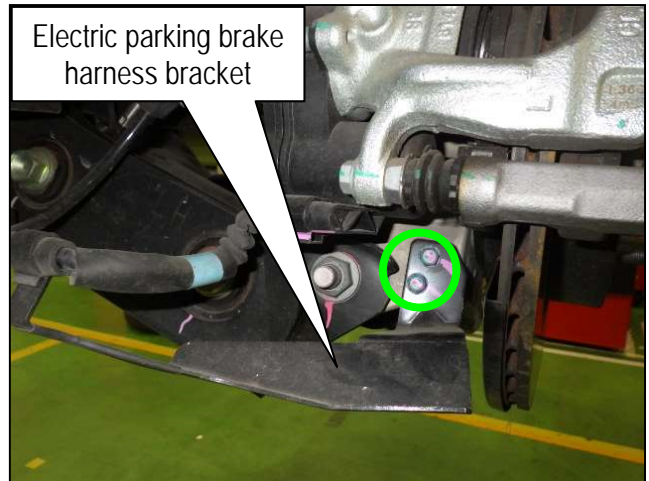

Figure 64

39. Remove the inner fender protector clip (Figure 65) and then position the inner fender protector out of the way as shown in (Figure 66).

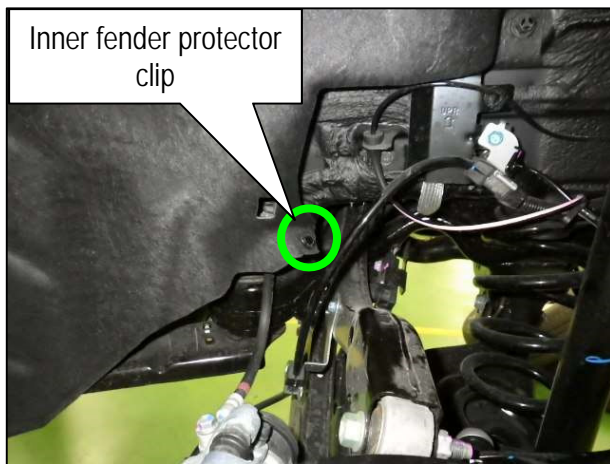

Figure 65

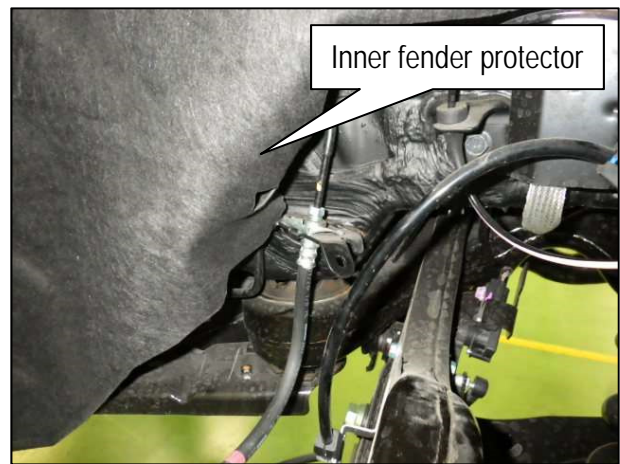

Figure 66

40. Remove the 2 rear brake caliper mounting bolts, and then remove the brake caliper from the rear knuckle.

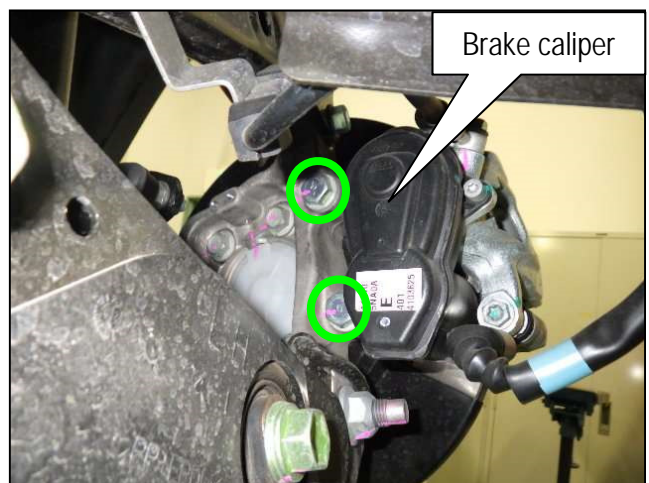

Figure 67

41. Remove the rear brake rotor.



Figure 68

NOTICE

To avoid damage to the drive shaft threads, loosen the wheel hub lock nut until the front face of the nut is even with the face of the drive shaft.

42. For AWD models, remove the cotter pin and loosen the wheel hub lock nut.
- Do not reuse the cotter pin.

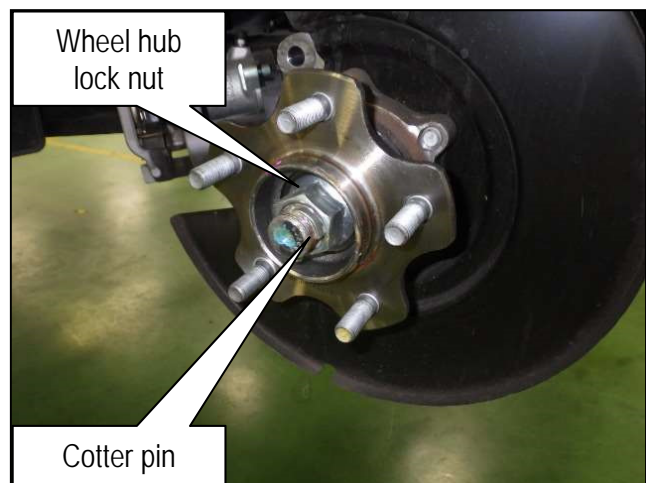

Figure 69

- Using a piece of wood or a suitable tool, tap on the face of the wheel hub lock nut to disengage the drive shaft from the wheel hub.
 - Once the drive shaft is disengaged from the wheel hub, remove the wheel hub lock nut
 - Do not reuse the nut.



Figure 70

43. On all models, remove the front lower link nut from the rear knuckle.

- Do not remove the bolt at this time.
- Do not reuse the nut.



Figure 71

44. Remove the rear lower link nut from the rear knuckle.

- Do not remove the bolt at this time.
- Do not reuse the nut.

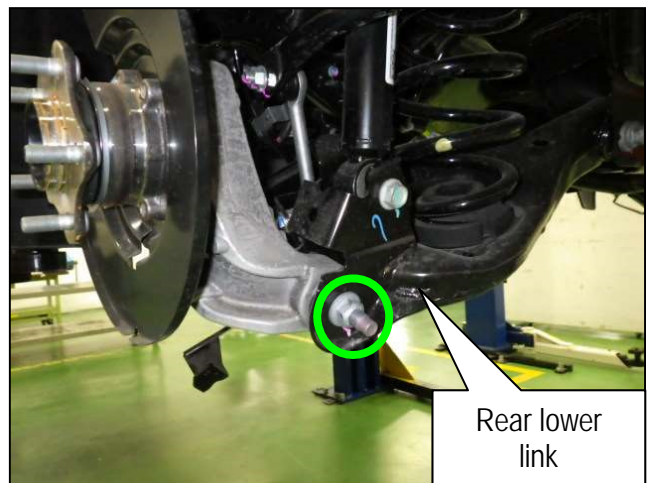

Figure 72

45. Remove the suspension arm nut from the rear knuckle.

- Do not remove the bolt at this time.
- Do not reuse the nut.

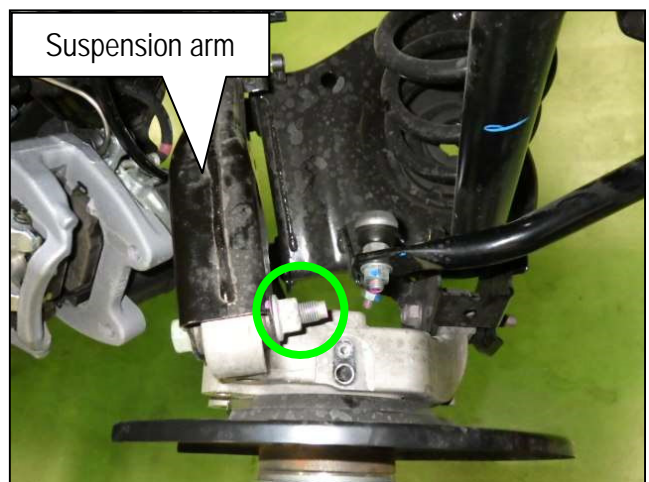

Figure 73

46. Remove the front lower link bolt.

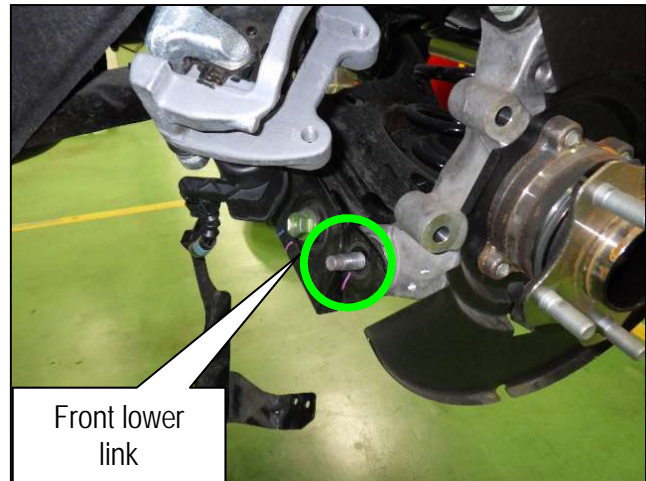

Figure 74

47. Remove the rear lower link bolt.

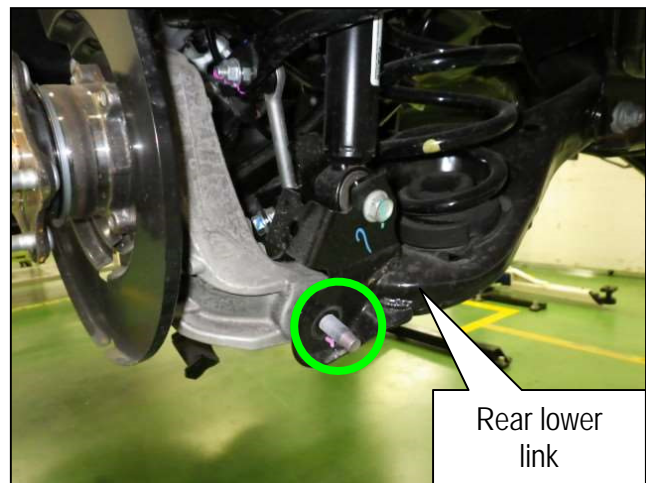

Figure 75

48. Swing the bottom of the rear knuckle out away from the lower links, and then remove the suspension arm bolt to remove the rear knuckle from the vehicle.

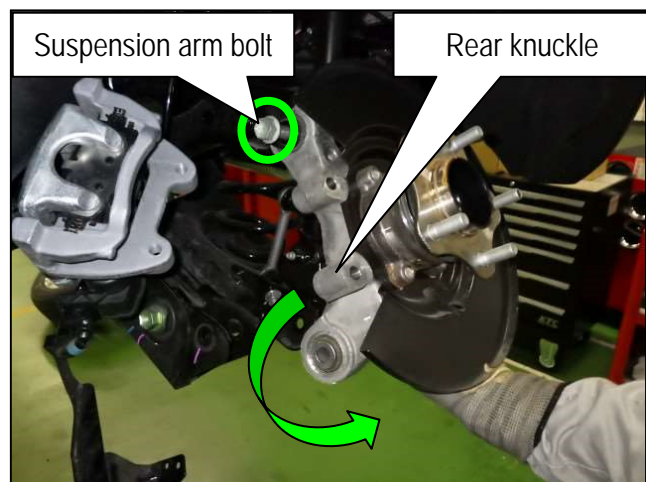

Figure 76

49. Repeat steps 34 - 47 on pages 20 - 24 for the opposite side of the vehicle, and then proceed to step 49 on page 25.

Disassemble The Rear Knuckle

50. Remove the 2 arm bushing stoppers from the rear knuckle.



Figure 77

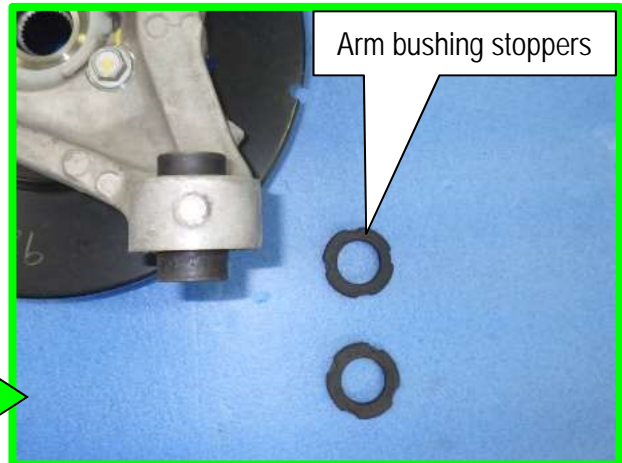

Figure 78

51. Secure the rear knuckle assembly in a vise and remove the 4 wheel hub bolts.

- Separate the dust shield (Figure 80) and wheel hub (Figure 81) from the rear knuckle.



Figure 79

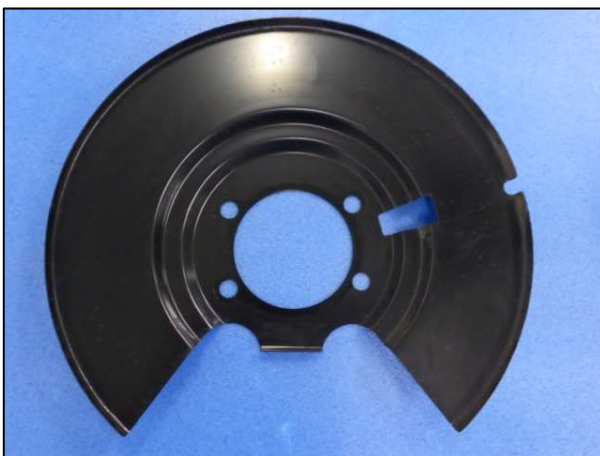

Figure 80



Figure 81

52. Remove the hub cap from the rear knuckle.

NOTE: The hub cap is different for FWD and AWD models. See Figure 83 for AWD models and Figure 84 for FWD models.

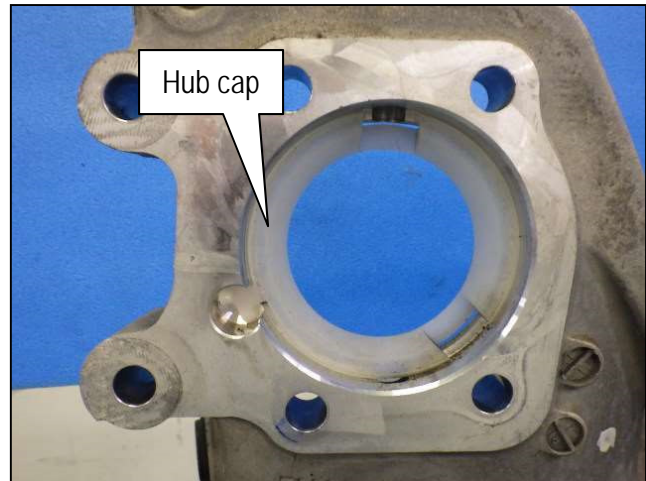

Figure 82

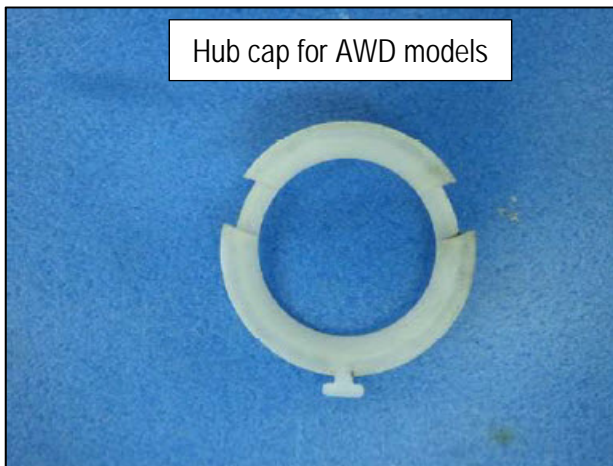

Figure 83



Figure 84

53. Repeat steps 49 – 51 on pages 25 - 26 for the opposite side of the vehicle, and then proceed to step 53 on page 27.

Confirm the Rear Knuckle Casting Stamp Date

The following Service Procedure uses an online form that must be filled out while performing the procedure.

54. Locate the casting stamp dates on each suspension knuckle, where indicated in Figure 85.

EXAMPLE:

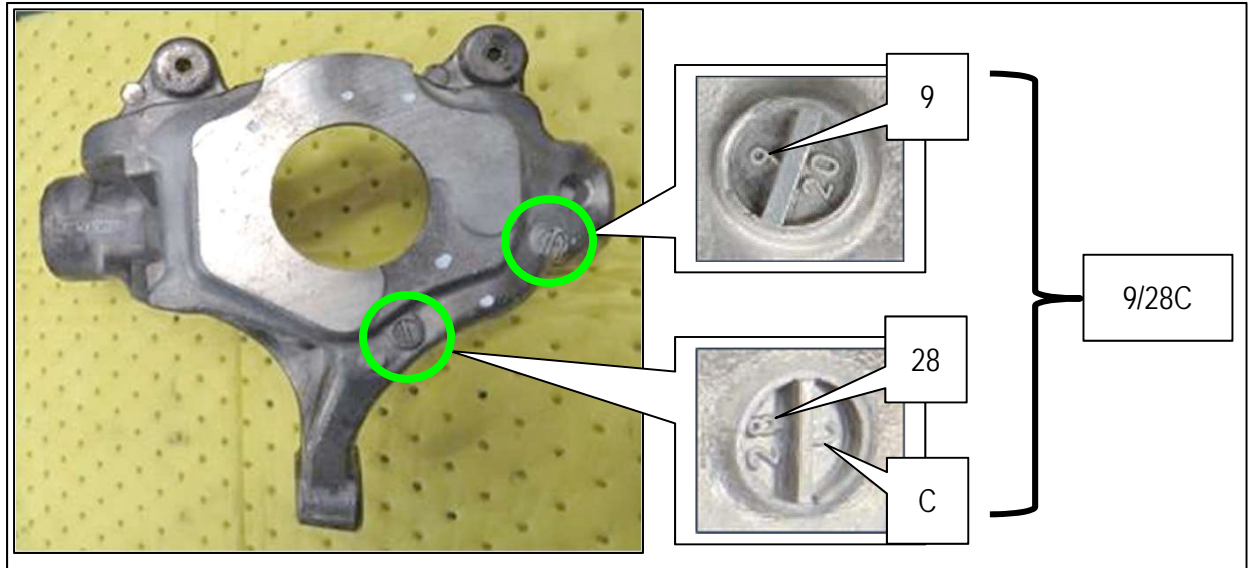

Figure 85

55. Open the ASIST form found at **ASIST > Tech Support Info > Bulletin Support Items > R21A5 Knuckle Inspection** (see Figure 86 and Figure 87).

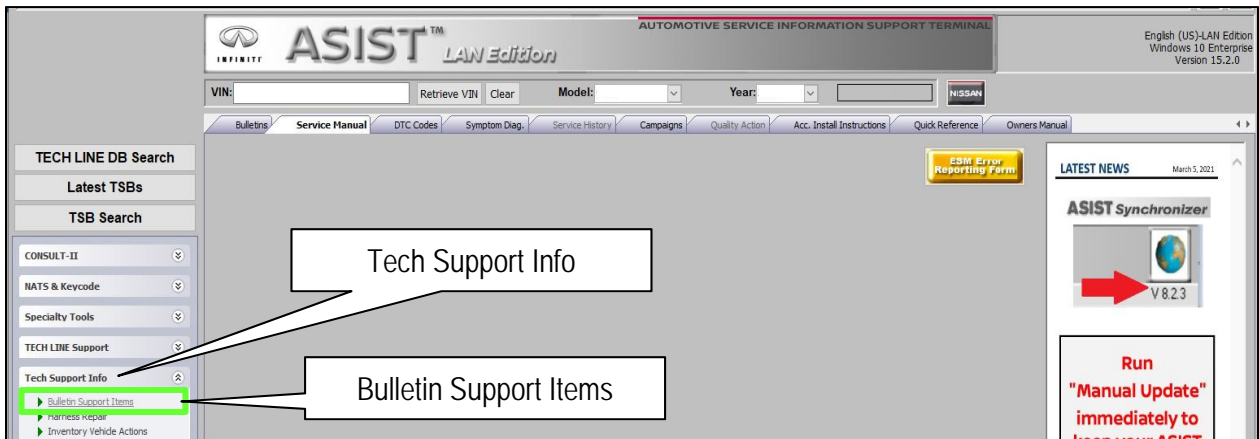

Figure 86

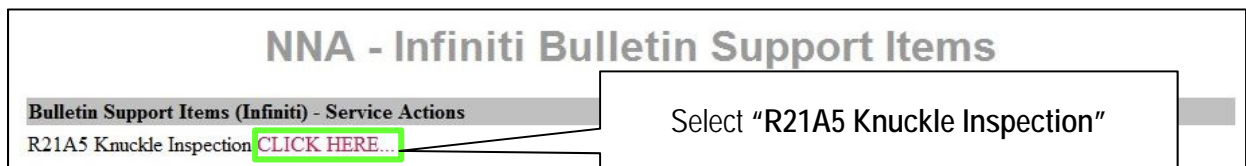

Figure 87

56. Enter the vehicle VIN and both casting stamp dates into the ASIST form, and then select **Submit** (Figure 31).
- If the ASIST inspection result is **OK** (Figure 88), print the Knuckle Inspection form and attach it to the work order. Skip to step 57 on page 29 to **reassemble** the original suspension knuckles.
 - If the ASIST inspection result is **NG** (Figure 89), print the Knuckle Inspection form and attach it to the work order. Place a parts order in DBS for the part number shown at the bottom of the Knuckle Inspection form, and proceed to step 56 on page 29 to **replace** the affected suspension knuckle(s).

R21A5 Knuckle Inspection

6/1/2021 1:09:14 PM (Mountain Standard Time)

Model

Input 17 digit VIN

Input Front Steering Knuckle Casting code

LH

RH

Input Rear Knuckle Casting code

LH

RH



Inspection is OK, Reassemble the vehicle and submit a Warranty Claim

Figure 88

R21A5 Knuckle Inspection

6/1/2021 1:08:40 PM (Mountain Standard Time)

Model

Input 17 digit VIN

Input Front Steering Knuckle Casting code

LH

RH

Input Rear Knuckle Casting code

LH

RH

NG- Replace the REAR (XX) knuckle using part number xxxxx-5NA0A . Print this page and attach to work order.

Figure 89

57. Secure the replacement rear knuckle in a vise.



Figure 90

Reassemble The Rear Knuckle

58. Install the hub cap to the rear knuckle.

NOTE: The hub cap is different for FWD and AWD models. See Figure 92 for AWD models and Figure 93 for FWD models.

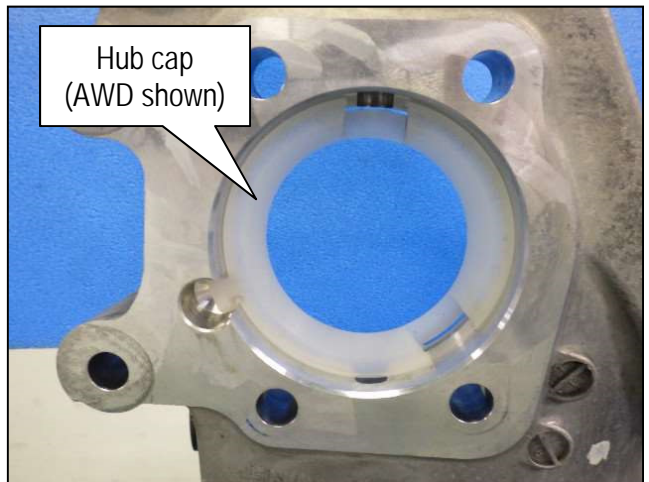
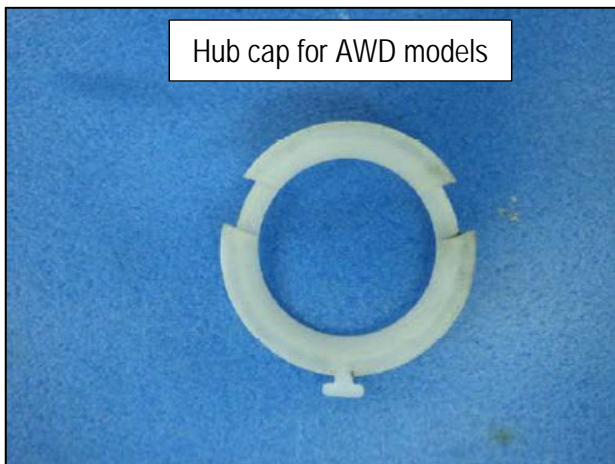

Figure 91



Hub cap for AWD models

Figure 92



Hub cap for FWD models

Figure 93

59. Clean the dust shield and hub bearing, and then install them to the rear knuckle using the original 4 bolts.

- Tighten the wheel hub bolts to 88.3 N·m (9.0 kg·m, 65 ft·lb).

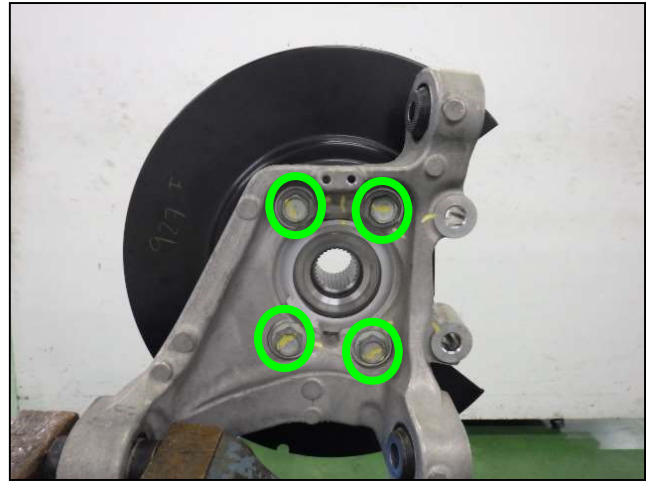

Figure 94

60. Install the 2 arm bushing stoppers to the rear knuckle.



Figure 95

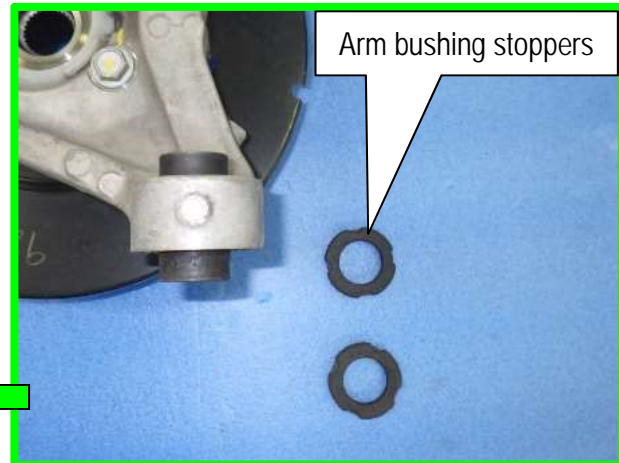

Figure 96

61. Repeat steps 57– 59 on pages 29 - 30 for the opposite side of the vehicle, and then proceed to step 61.

Install The Rear Knuckle

62. Install the rear knuckle assembly by installing the original suspension arm bolt to the rear knuckle assembly, and then swing the bottom of the rear knuckle in toward the lower links.

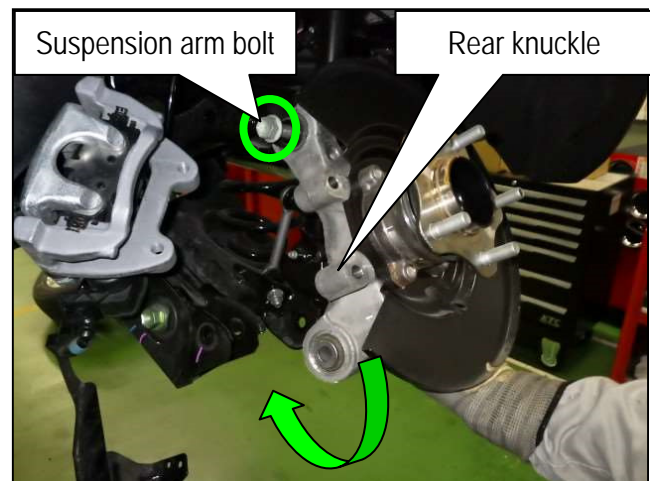

Figure 97

63. Install the rear lower link bolt.

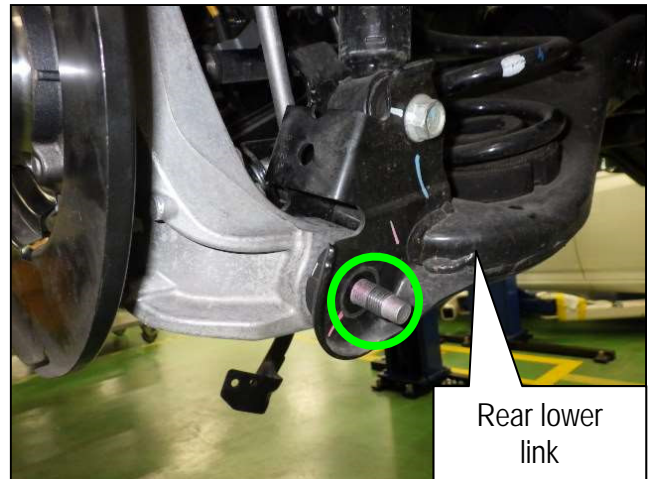

Figure 98

64. Install the front lower link bolt.

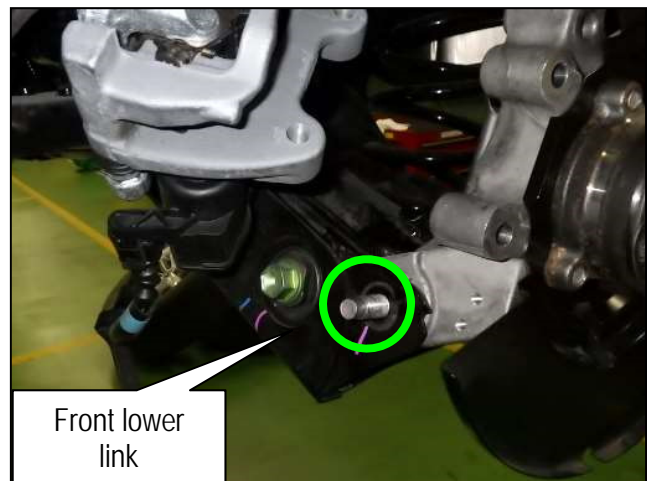

Figure 99

65. Install a **new** nut to the suspension arm bolt.

- Hand-tighten the nut at this time, do not torque.

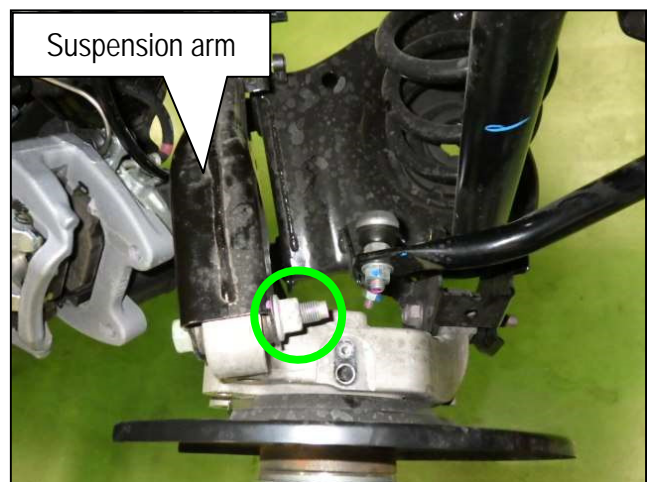

Figure 100

66. Install a **new** nut to the rear lower link bolt.

- Hand-tighten the nut at this time, do not torque.

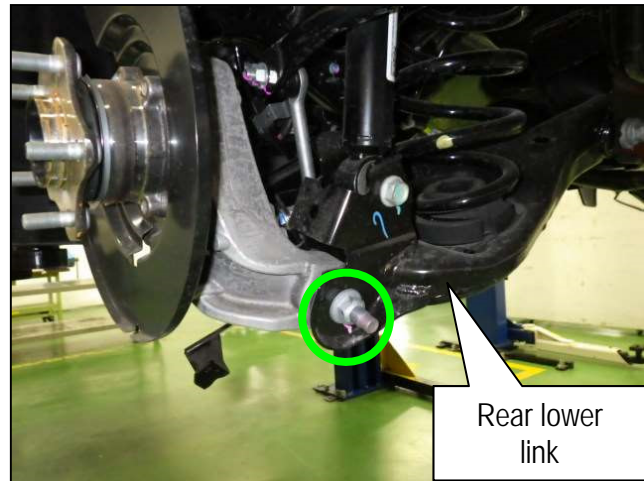

Figure 101

67. Install a **new** nut to the front lower link bolt.

- Hand-tighten the nut at this time, do not torque.



Figure 102

68. Slightly raise the rear suspension using a suitable jack.

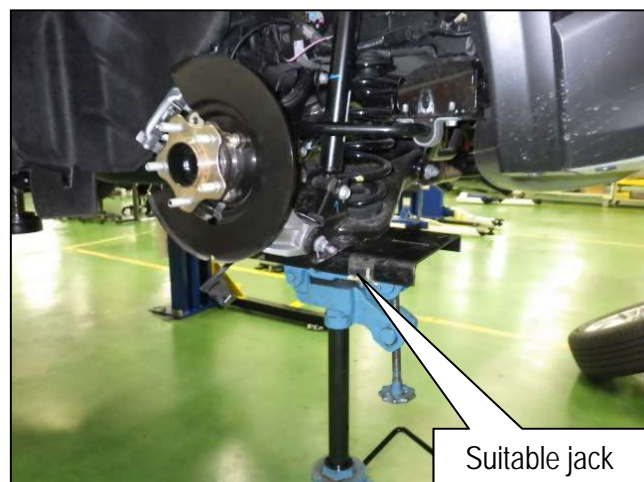

Figure 103

69. Tighten the front lower link nut, rear lower link nut, and the suspension arm nut.

- Tighten the front and rear lower link nuts and the suspension arm nut to 167.5 N·m (17.0 kg-m, 124 ft-lb).

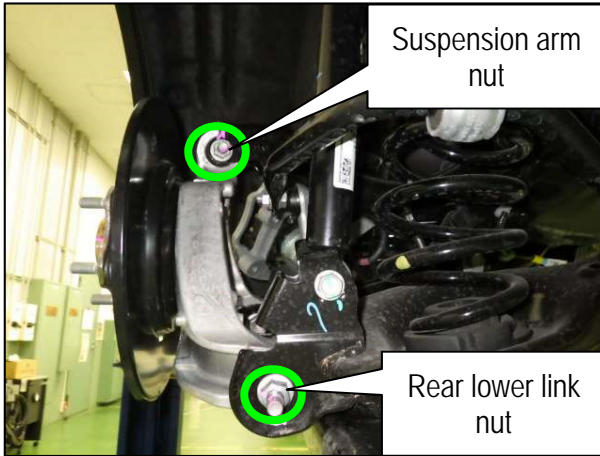

Figure 104

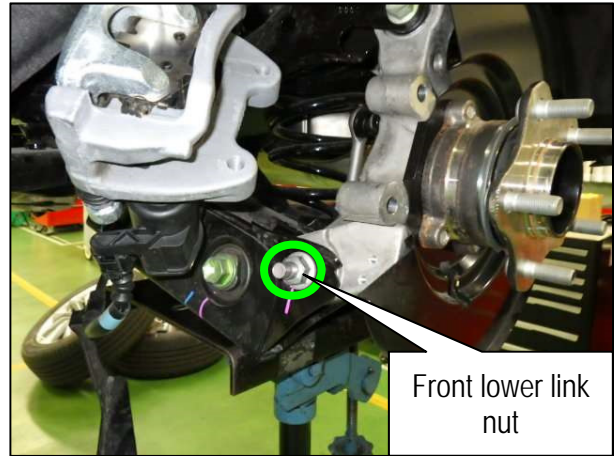

Figure 105

70. Lower the jack and remove.

71. Install the brake rotor to the rear knuckle.

- Make sure the alignment mark on the brake rotor is aligned with the mark on the wheel hub.
- Use a wheel nut to secure the brake rotor in place.

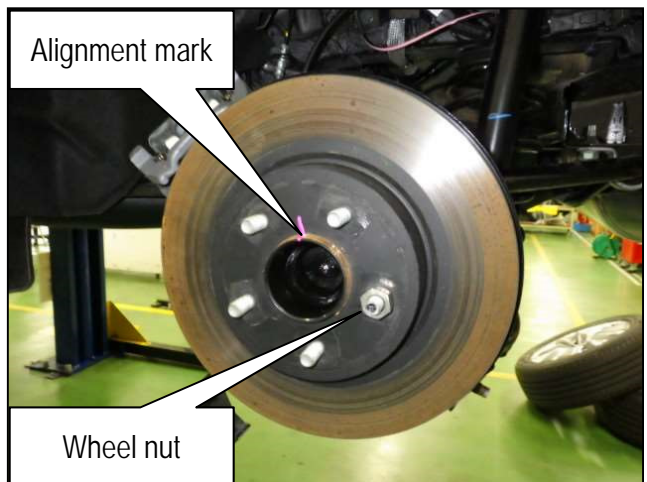

Figure 106

72. Install the brake caliper using the existing bolts.

- Tighten the brake caliper mounting bolts to 76.5 N·m (7.8 kg-m, 56 ft-lb).

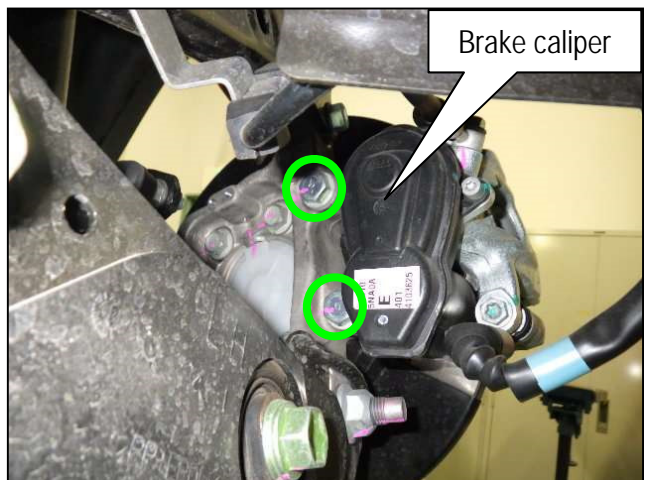

Figure 107

73. Position the inner fender protector into the original position and install the fender protector clip.

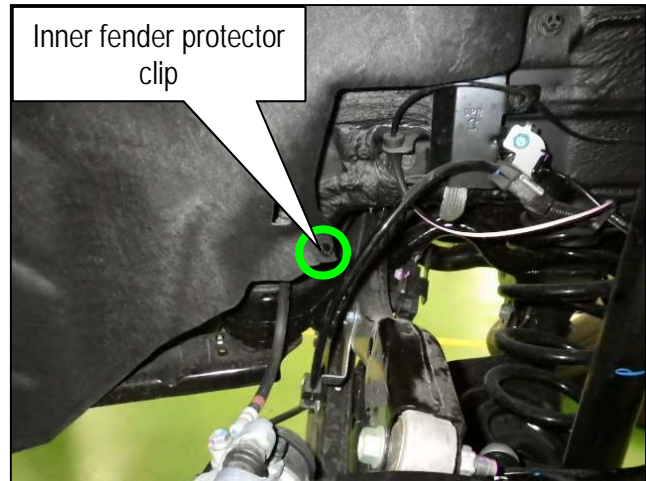

Figure 108

74. Install the electric parking brake harness bracket to the rear knuckle using the original bolts.
- Tighten the parking brake harness bracket bolts to 13.0 N·m (1.3 kg·m, 114 in-lb).

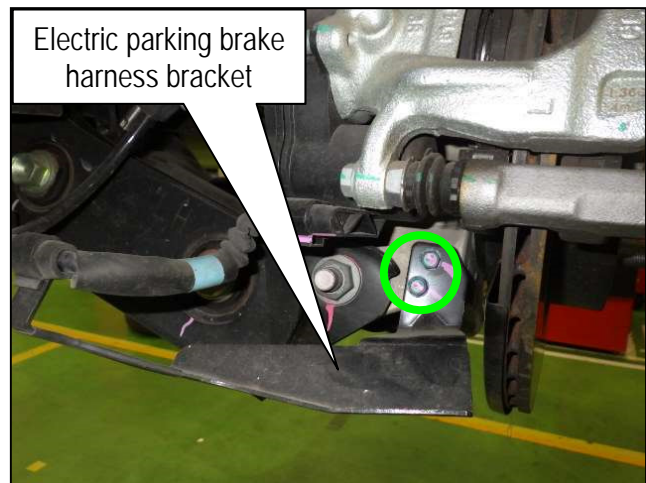

Figure 109

75. Install the rear wheel speed sensor and the wheel speed sensor harness bracket to the rear knuckle using the original bolts.
- Tighten the wheel speed sensor bolt to 9.0 N·m (0.9 kg·m, 80 in-lb).
 - Tighten the wheel speed sensor harness bracket bolt to 17.0 N·m (1.7 kg·m, 150 in-lb).

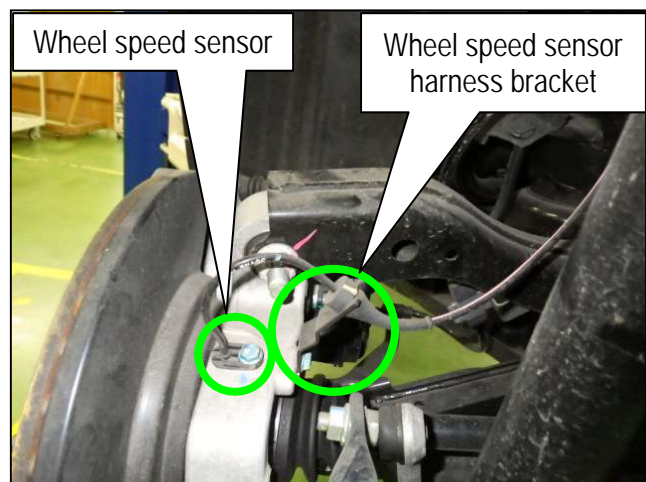

Figure 110

76. For AWD models, install a **new** wheel hub lock nut.
- When assembling the drive shaft, pull the driveshaft in until it is fully seated by tightening the wheel hub lock nut.
 - Tighten the wheel hub lock nut to 140.0 Nm (14.0 kg-m, **103 ft-lb**).



Figure 111

- Install a **new** cotter pin.
- Remove any wheel nuts securing the disc brake rotor.



Figure 112

77. On all models, repeat steps 61 - 75 on pages 30 - 35 on the opposite side of the vehicle, and then proceed to step 77.
78. Install both rear wheel and tire assemblies.
- Tighten the wheel nuts to 113 N·m (12 kg-m, **83 ft-lb**).

79. Perform a 4-wheel alignment.
80. Adjust the steering angle sensor neutral position using the CONSULT-III plus.
- To adjust the steering angle sensor neutral position on EPS equipped vehicles, refer to the ESM section below.
 - **DIAGNOSIS > BRAKES > BRAKE CONTROL SYSTEM > VDC/TCS/ABS > BASIC INSPECTION > ADJUSTMENT OF STEERING ANGLE SENSOR NEUTRAL POSITION.**
 - To adjust the steering angle sensor neutral position on DAST equipped vehicles, refer to the ESM section below.
 - **DIAGNOSIS > STEERING > STEERING CONTROL SYSTEM > DIRECT ADAPTIVE STEERING > BASIC INSPECTION > DAST CALIBRATION (MODE 1).**

IMPORTANT: Follow all cautions and notices in the ESM procedure.

PARTS INFORMATION

DESCRIPTION	PART NUMBER	QUANTITY
HOUSING ASSY-REAR AXLE LH	D3019-5NA0A	1
HOUSING ASSY-REAR AXLE RH	D3018-5NA0A	1
NUT	40262-4GA0C	2
NUT	54588-EN00A	4
NUT-HEX (AWD ONLY)	40262-2Y00A	2
NUT-KNUCKLE SPINDLE	40262-JA000	6
PIN-COTTER, SPLIT	08921-3202A	2
PIN-COTTER (AWD ONLY)	40073-0L700	2
SPINDLE-KNUCKLE, LH	D0015-5NA0A	1
SPINDLE-KNUCKLE, RH	D0014-5NA0A	1

CLAIMS INFORMATION

Submit a "CM" line claim using the following claims coding:

CAMPAIGN ("CM") ID	MODEL	DESCRIPTION	OP CODE	FRT
R21A5	QX50 2WD	Inspect all suspension knuckles	R21A56	5.9 hrs
		Inspect all suspension knuckles and if necessary, replace	R21A57	5.9 hrs
	QX50 AWD	Inspect all suspension knuckles	R21A58	6.2 hrs
		Inspect all suspension knuckles and if necessary, replace	R21A59	6.2 hrs

AMENDMENT HISTORY

PUBLISHED DATE	REFERENCE	DESCRIPTION
July 6, 2021	ITB21-018	Original bulletin published

