



Spare Tire Carrier - Modification

Bulletin Type:	Recall	Publication Date:	June 2021
Bulletin #(s):	21V-317 US 2021-272 Canadian	Make(s):	Jayco
Job Code(s):	9901566	Model(s):	Jay Feather Micro
Flat Rate(s):	A. .10 Hr. Inspection for Z-brackets. B. .25 Hr. Inspection and Install Z-brackets C. .50 Hr. Inspection and Install Spare Tire Carrier + Z-brackets. Note: Only use this code if spare tire carrier has physical damage.	Model Year(s):	2021

Incident:	Spare tire carrier may break at bend radius or gusset and fall/detach from the travel trailer during transit.
Affected Units:	M1JG0051-0379 M1JK0050-0321 M1JM0051-0102
Part Kit Numbers: 21V-317A 21V-317B	<p>Part Kit Contents:</p> <p>21V-317A: Standard kit 1 - Norco Service Bracket Kit (Includes two Z-brackets & four 3/8-16 serrated flange nuts). #2026910 2 - Lug Nuts, 0.50-20 Stainless Steel 3/4" HEX for aluminum wheels. #0713240</p> <p>21V-317B: Only order this kit if the spare tire carrier has physical damage. 1-Spare Tire Carrier # 2014093 (Norco#20400292) w/ Z-Brackets 2-Lug Nuts, 0.50-20 Stainless Steel 3/4" HEX for aluminum wheels. #0713240</p>
Misc. Tools & Supplies:	13/16" Thin Wall Socket 3/4" Deep Thin Wall Socket 9/16" Deep Socket Socket Wrench Torque wrench
Parts Return Information:	No Part Return

INSPECTION STEPS

- 1.) Remove nuts holding spare tire onto spare tire carrier with a 13/16" thin wall socket.
- 2.) Remove spare tire from carrier.
- 3.) Inspect spare tire carrier for Z-brackets already installed. No further action needed.
- 4.) Inspect spare tire carrier for any physical damage in the Circlred area identified below.

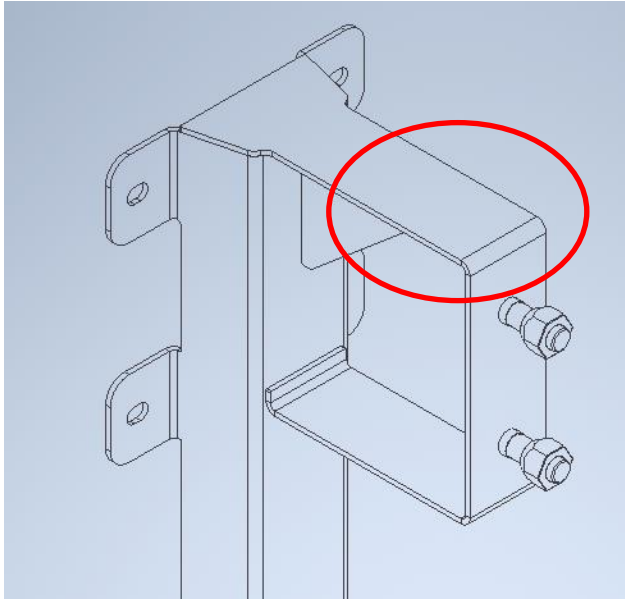

5.) If spare tire carrier has damage replace complete spare tire carrier AND add two Z brackets.
Order Kit 21V-317B.

6.) If **spare tire carrier has no physical damage and there are no Z-brackets installed,** add two Z-brackets to spare tire carrier.
Order Kit 21V-317A.

See instructions details starting on page 3.

Installing Z-Brackets onto Tire Carrier

- 1.) Slide one Z-bracket over spare tire carrier studs and over 3/8" bolts.



- 2.) Slide second Z-bracket over spare tire carrier studs and over 3/8" bolts.



- 3.) Using just your hand, start threading a 3/8"-16" serrated flange nuts onto 3/8" bolts protruding out of rear wall.



- 4.) Once all of the 3/8"-16 nuts are started, use 9/16" deep socket and tighten nuts to 30 ft.-lbs. against each Z-bracket.



5.) When all 3/8"-16 nuts are tightened, re-check that all nuts are torqued to 30 ft.-lbs. The completed installation should look as shown below.



6.) Position spare tire back onto spare tire carrier.

- 7.) Using the two ½-20 lug nuts provided with service kit, use ¾” deep thin wall socket and secure spare tire to spare tire carrier by torquing nuts to 90 ft.-lbs. The completed installation should look like one of the two configurations shown below.



Jayco's sole obligation under our limited warranty is to repair or replace defective materials and/or workmanship deemed our responsibility as determined by Jayco in our sole discretion. Jayco reserves the right to use new and/or remanufactured parts or materials of similar quality to complete any work, and to make parts and/or design changes as appropriate without notice to anyone. Jayco designs and/or materials changes are done without obligation to incorporate such changes in previously manufactured product. Jayco makes every reasonable effort to ensure field remedies will not adversely affect performance and/or safety of the unit. This field remedy is not intended to extend to future performance of this RV, or any of its materials, components or parts beyond the standard warranty period. The RV owner's obligation to notify Jayco, or one of its independent, authorized dealers, of a claimed defect does not modify any obligation placed on the RV owner to contact Jayco directly when attempting to pursue remedies under state or federal law. Jan. 2019.

903 South Main Street • P.O. Box 460 • Middlebury, IN 46540