

# SAFETY RECALL

Mack Trucks Inc.  
Greensboro, NC USA



---

Date	Number	Release	Page
04.2021	SC0424	02	1(30)

## Steering Transfer Case LR

### RECALL INFORMATION

**Revised 3/13/2026 Updated the Parts order process.**

(April, 2021)

Mack Trucks, Inc. (Mack) is recalling certain 2018 & 2019 LR model vehicles. The issue is with the steering transfer case (commonly referred to as the miter box), which may have not received the required amount of oil at the supplier's manufacturing facility. As a result, the internal bearings may fail and cause steering lock-up, which under certain conditions increases the risk of a vehicle crash.

Mack Trucks has not received any complaints or reports of vehicle crashes because of this Safety Recall.

To ensure the safety of these vehicles follow the repair process in this document to inspect the steering transfer case build date and as necessary replace the component.

### VEHICLES AFFECTED

Certain Mack North America vehicles manufactured between November 28th, 2018 and January 31st, 2019.

### VEHICLE QUANTITY

There are 276 vehicles affected by this recall (272 U.S., 4 Canada).

**Parts**

<b>NOTE</b>
Parts Listed below are only needed if the Transfer Case requires replacement. The <b>Inspection of the component</b> must be completed <b>prior to ordering parts.</b>

**Ordering Process**

Order all parts through the normal process.

<b>Parts List</b>		
<b>Part Number</b>	<b>Description</b>	<b>Qty</b>
84726804	Transfer Case	1
25106380	Hexagon Screw	3
25098472	Nut Retainer	3

**Return**

<b>NOTE</b>
Parts are on Mandatory Return.

### Inspection Instructions

1. Secure the truck for service.
2. Position drive wheels in the straight-ahead position.
3. Disconnect Battery's.
4. Remove both right and left side grab handles.

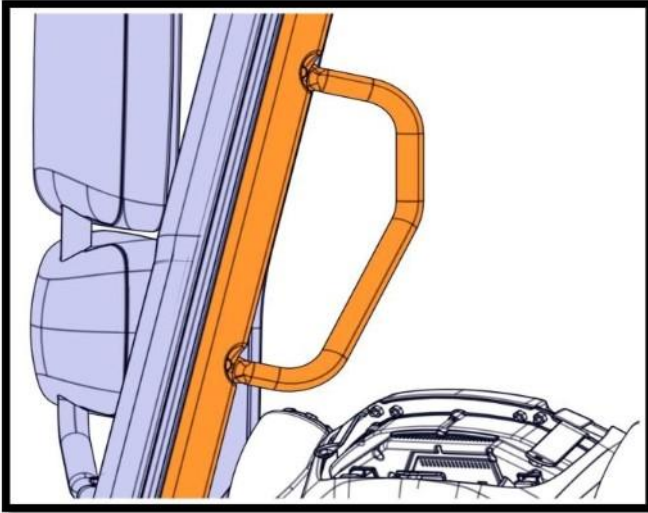

5. Remove right side upper dash bezel.

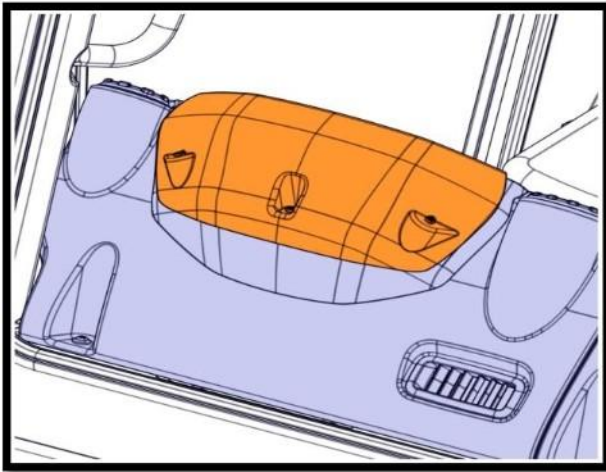

6. Remove upper dash panel

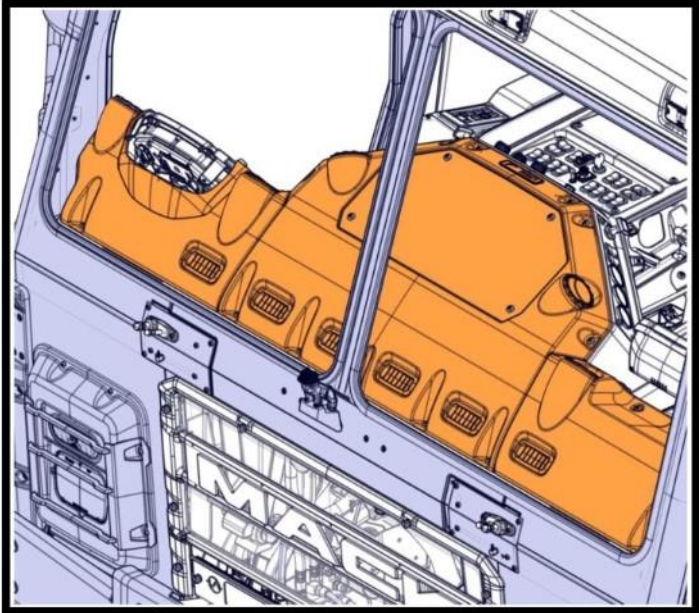

7. Remove two lower transfer case fasteners and loosen the two upper transfer case fasteners.

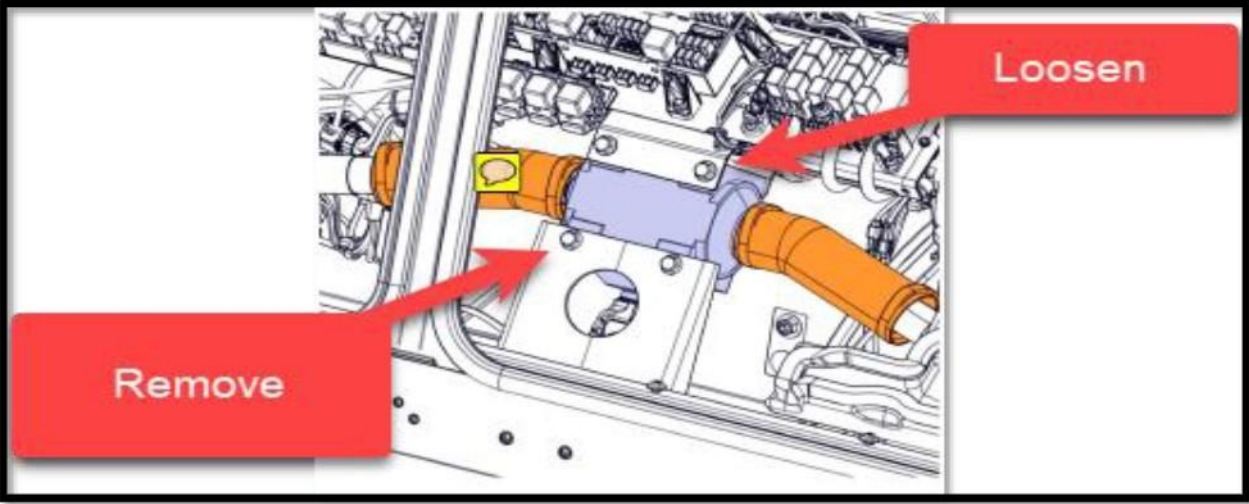

- Using suitable tool, lift the lower transfer case mounting bracket away from the transfer case enough to see the date code on the transfer case identification tag.



9. Using the Date Code on the Transfer Case Identification tag determine if the component requires replacement:

- a. If the date code is 11/06/18 the Transfer Case will need to be replaced (example of the identification tag can be seen below). Continue to the **Replacement Instruction** section of this document below for the continued repair.
- b. If the date code is anything other than 11/06/18 the component does NOT require replacement. Reassembled the vehicle for return to service and continue to the **Completion Label** section of this document.

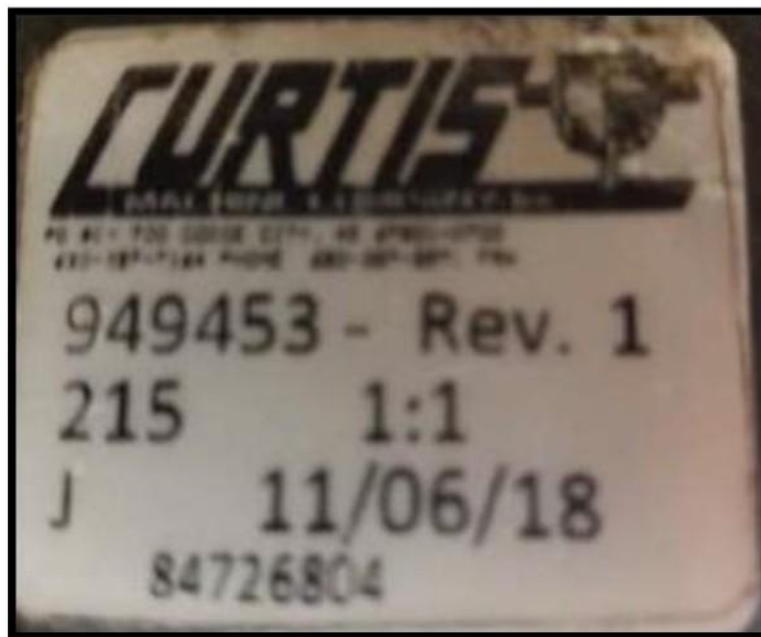

## Replacement Instructions

### NOTE

The instruction below are for Dual Steer configuration. Left or right side steer vehicle configurations may be able to omit steps that do not apply.

1. Park the vehicle on a level surface with the steering wheel in the straight-ahead position.
2. Apply the parking brake.
3. Place the gear lever in neutral.
4. Install wheel chocks.

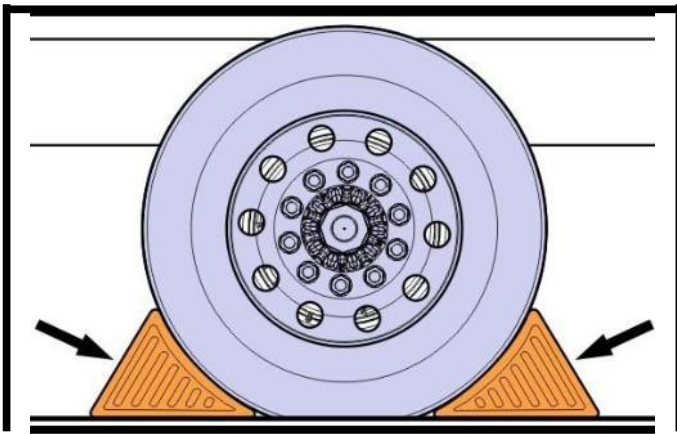

5. Disconnect the cable from the battery's negative terminal.

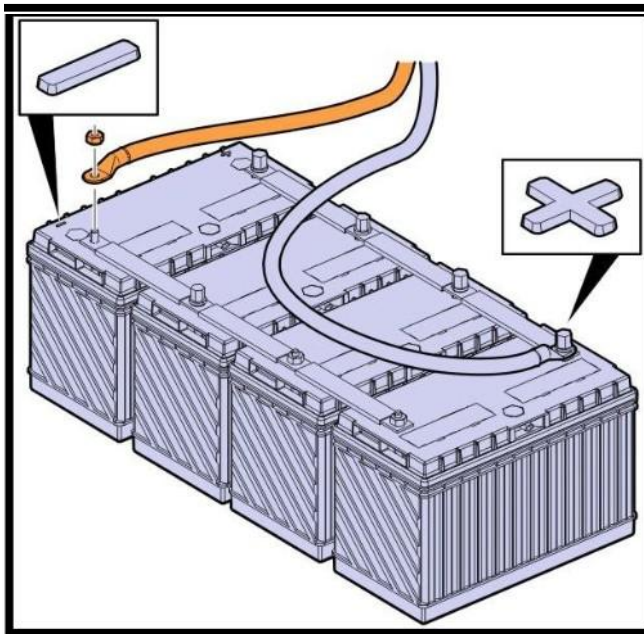

6. Remove the Nuts (1).

7. Remove the nuts (2).
8. Remove the wiper arms.

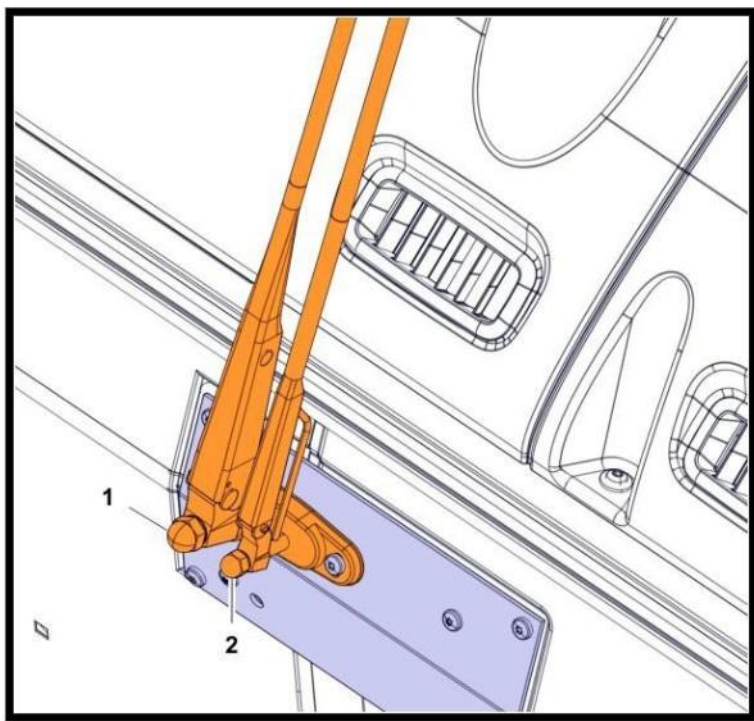

**WARNING**

Risk of serious injury.

Heavy component.

► Exercise caution when moving the component. Assistance is required.

9. Remove the windshields.

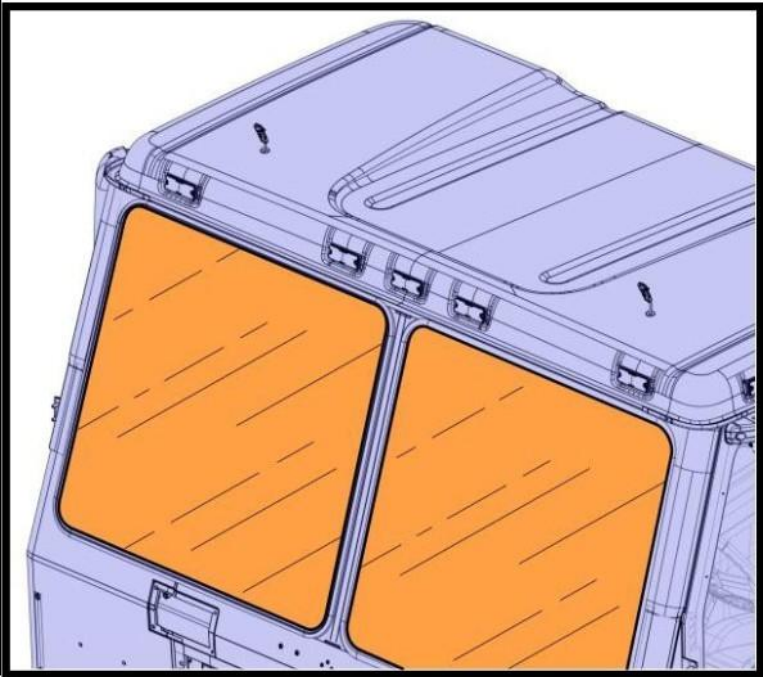

10. Remove the horn button.

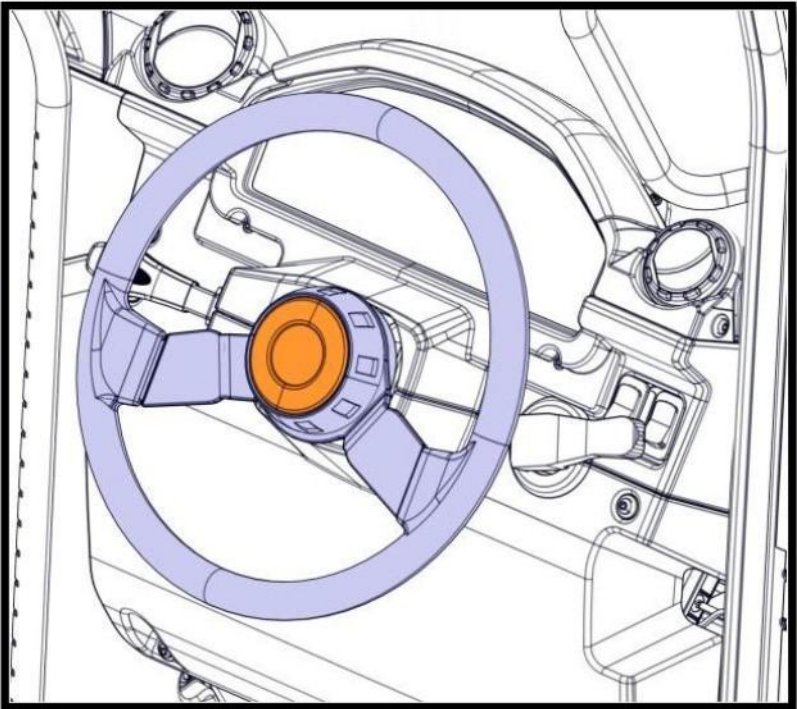

- 11. Remove the nut.
- 12. Remove the steering wheel.

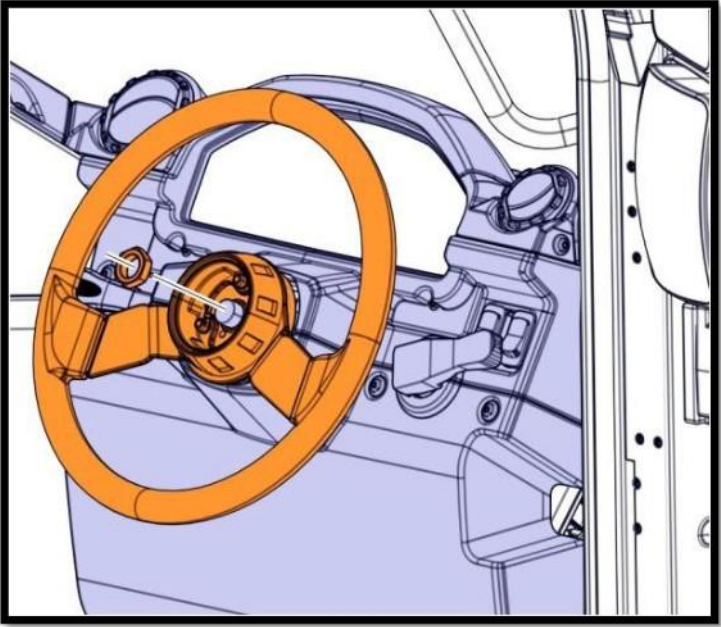

- 13. Remove the screws.
- 14. Remove the bezel.

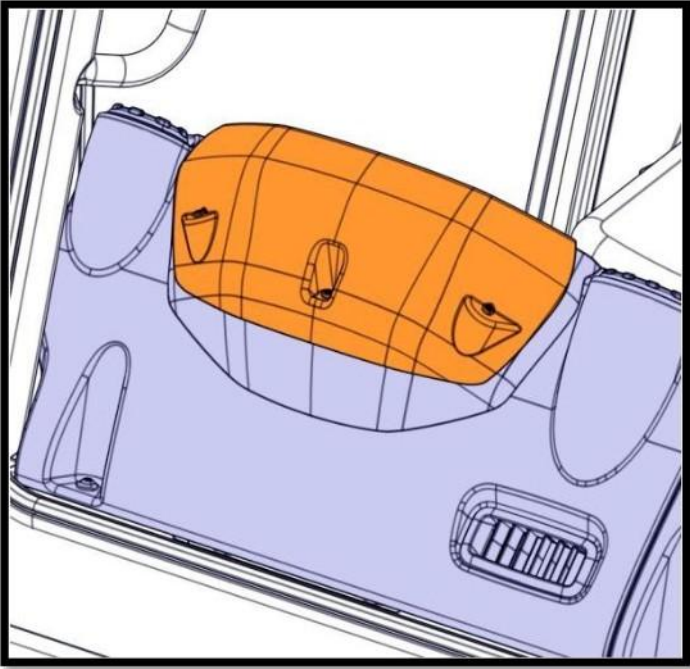

15. Remove the horn button.

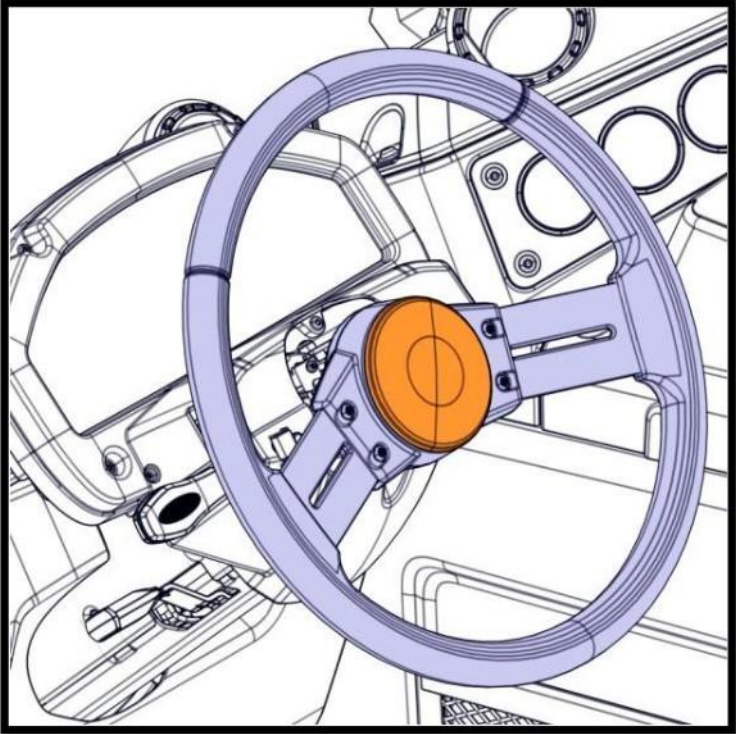

16. Remove the nut.

17. Remove the steering wheel.

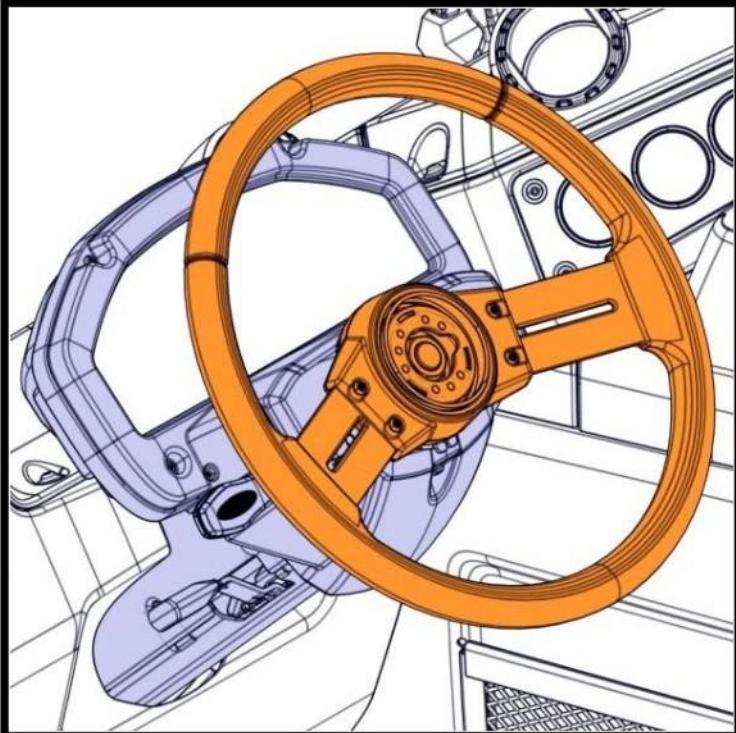

- 18. Remove the screws.
- 19. Remove the trim panel.

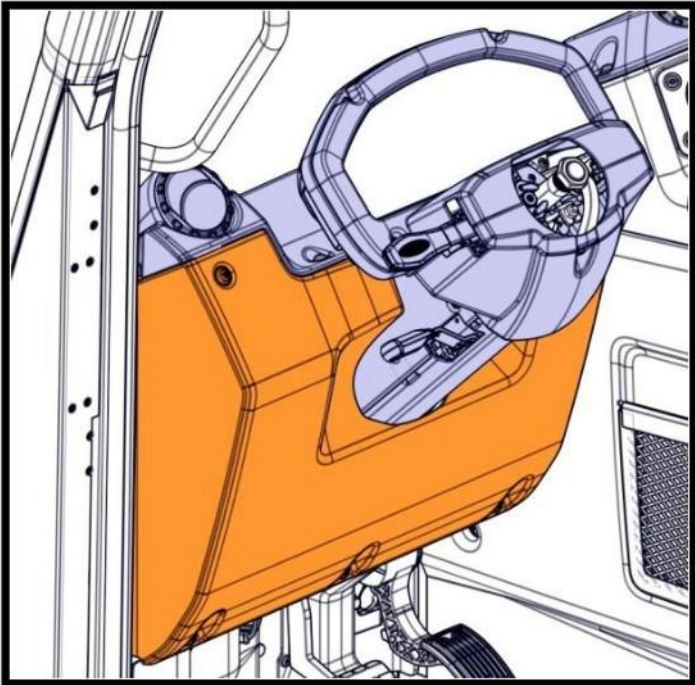

- 20. Remove the screws.
- 21. Remove the bezel.

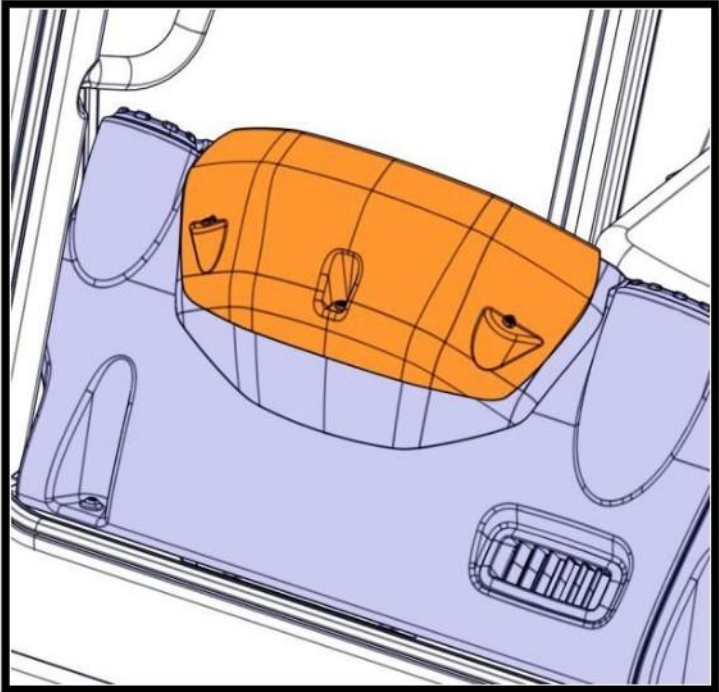

- 22. Remove the handle.
- 23. Remove the A-pillar trim panel.

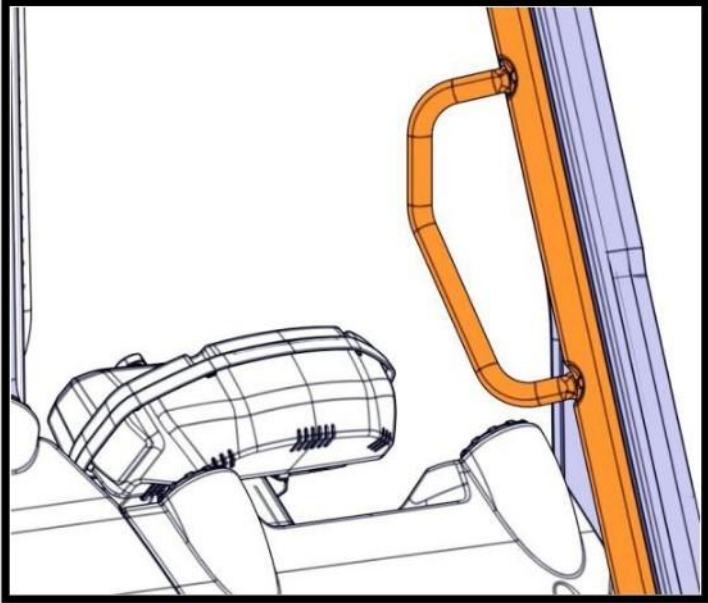

- 24. Remove the handle.
- 25. Remove the A-pillar trim panel.

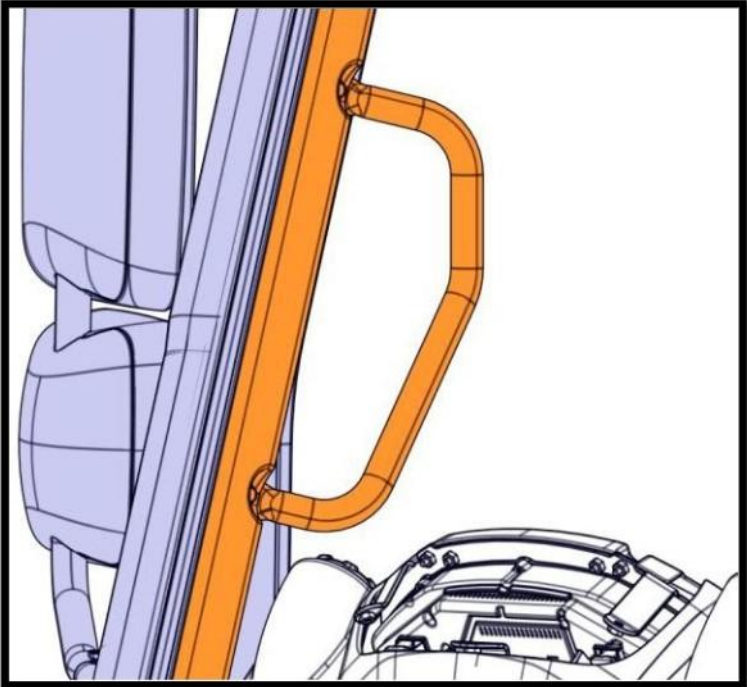

- 26. Remove the screws.
- 27. Remove the panel.

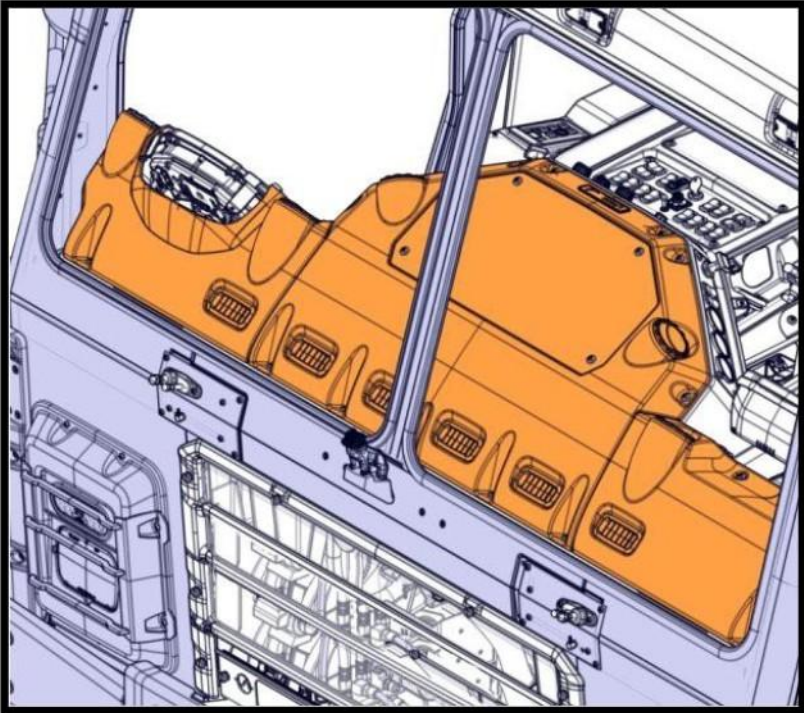

- 28. Remove the covers.

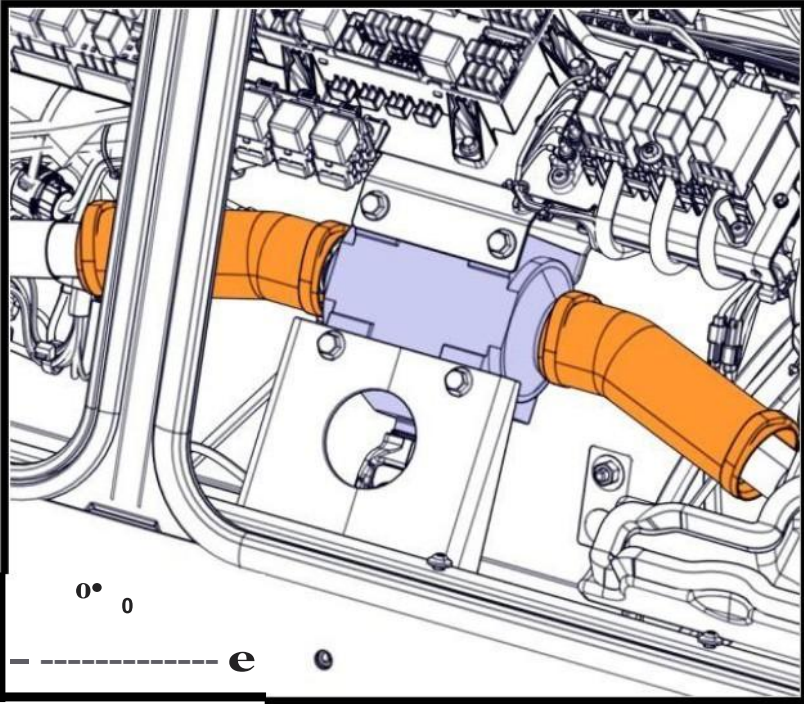

29. Remove the nuts and screws.

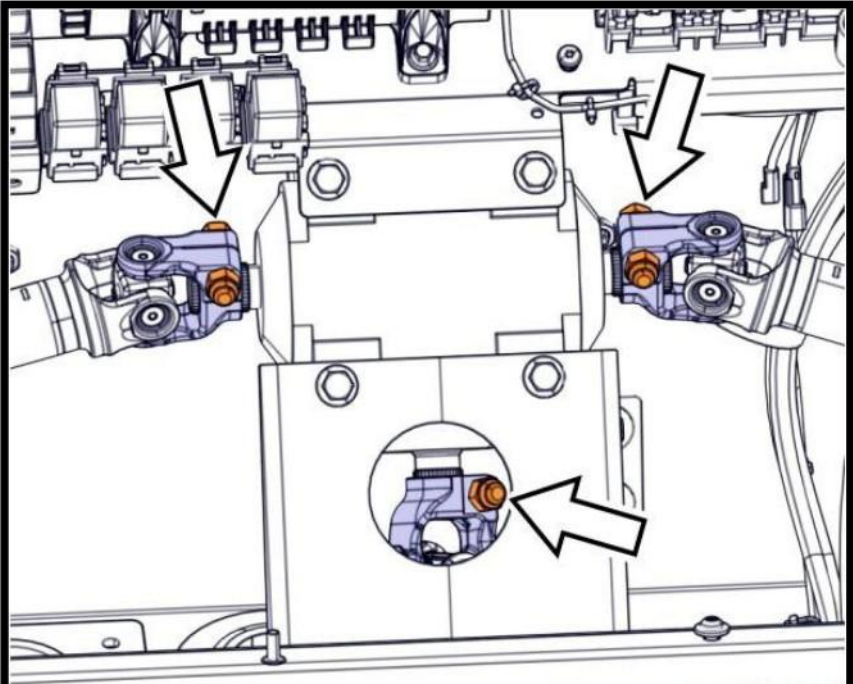

30. Remove the steering shafts.

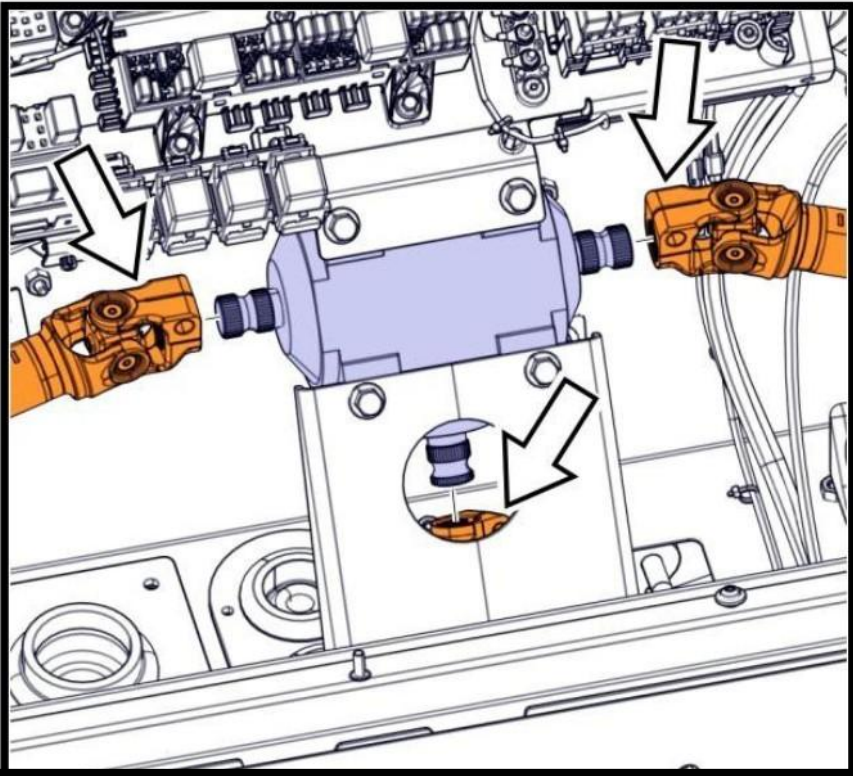

31. Remove the screws.

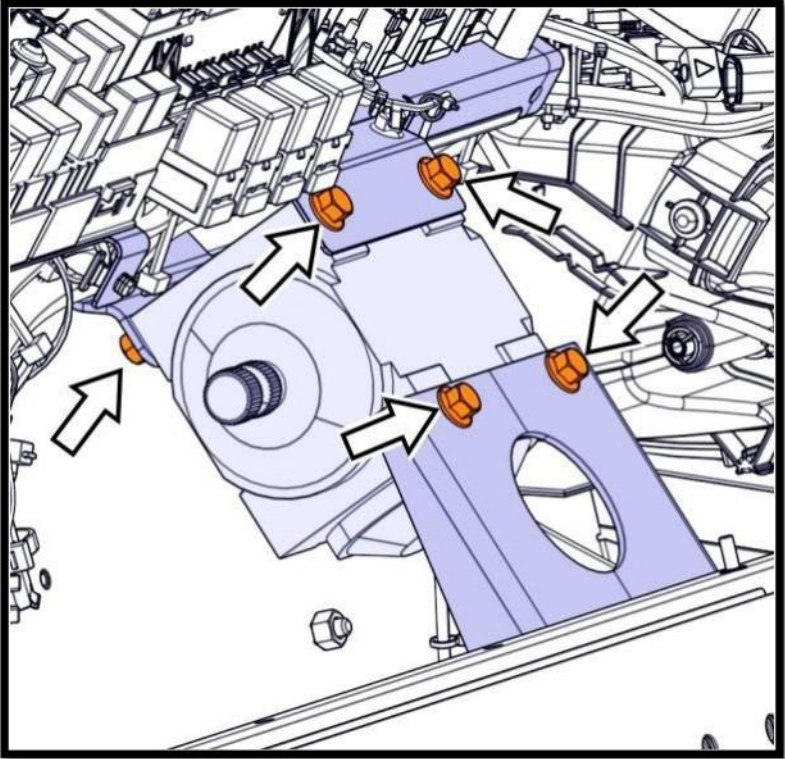

32. Remove the transfer box.

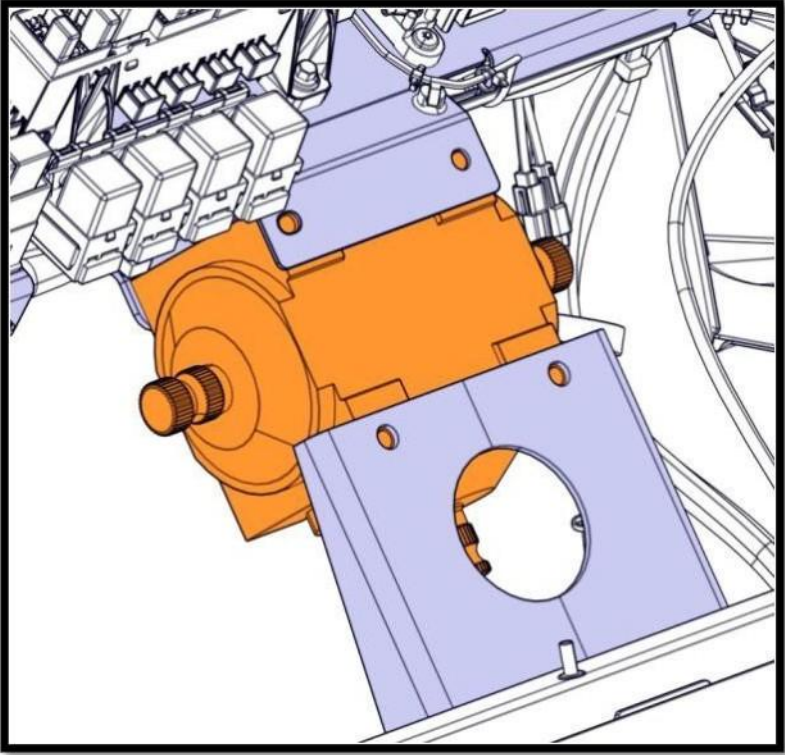

<b>NOTE</b>
Parts are on Mandatory Return.

33. Position the transfer box.

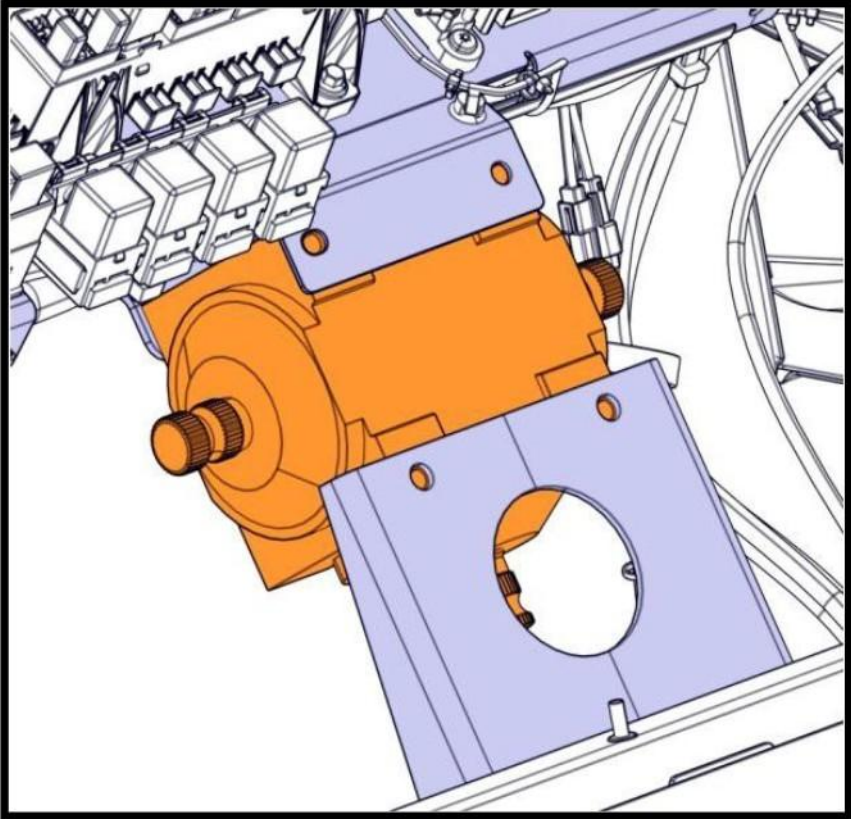



34. Install the screws.

35. Torque Tighten the screws.

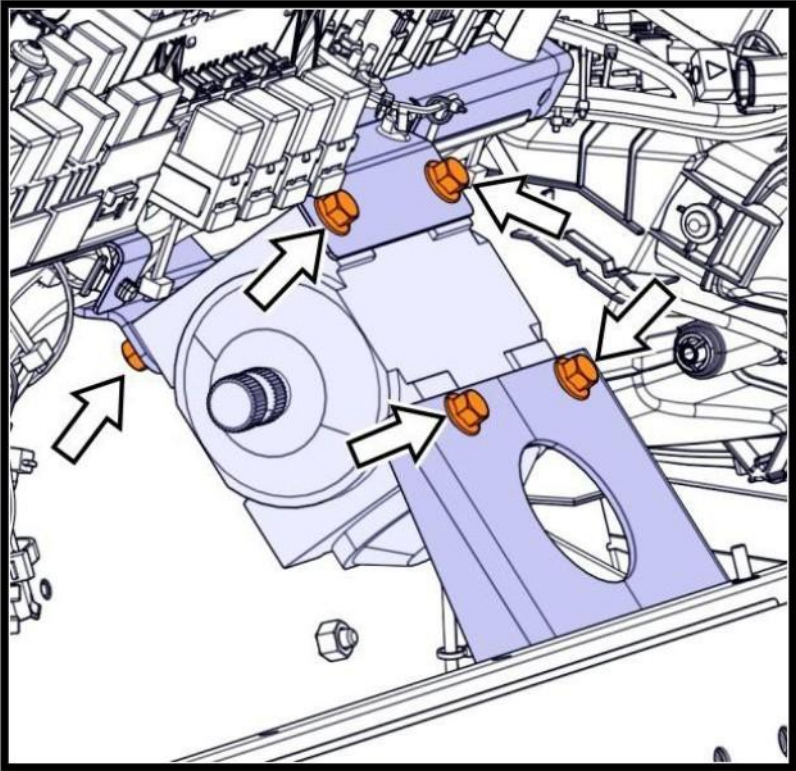
Tightening torque	
Transfer box, screw	48 ±8 Nm (35 ±6 lb( ft)



36. Install the steering shafts.

	<p><b>Note</b> Make sure the steering wheel is straight and the front wheels are pointed straightahead.</p>
	<p><b>Note</b> The pinch bolt must be staggered from left to right.</p>

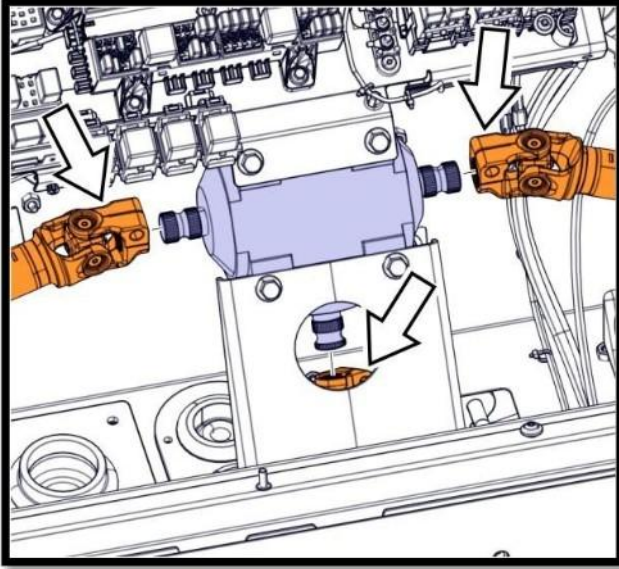

37. Install the screws and nuts.

	<p><b>Note</b> Use new fasteners.</p>
---	---

38. Torque tighten the nuts.

Tightening torque	
Steering shaft, nut	85 ±15 Nm (63 ±11 lb( ft)

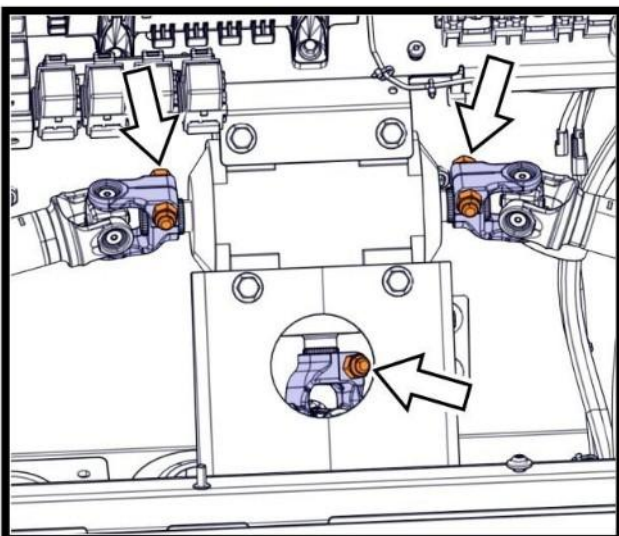

39. Install the covers.

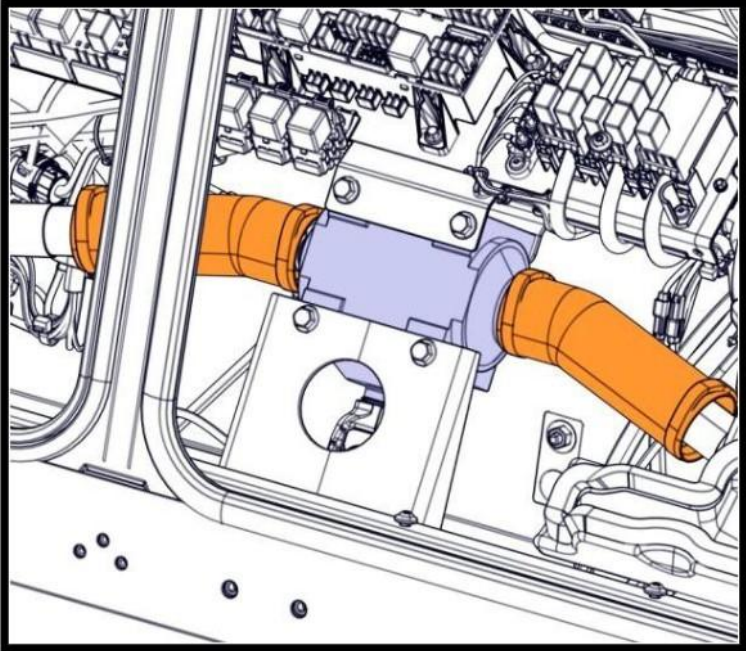

40. Install the panel.

41. Install the screws.

42. Tighten the screws to torque.

Tightening torque	
Panel, screw	3.4 ±0.6 Nm (3 ±0.4 lb{ ft)

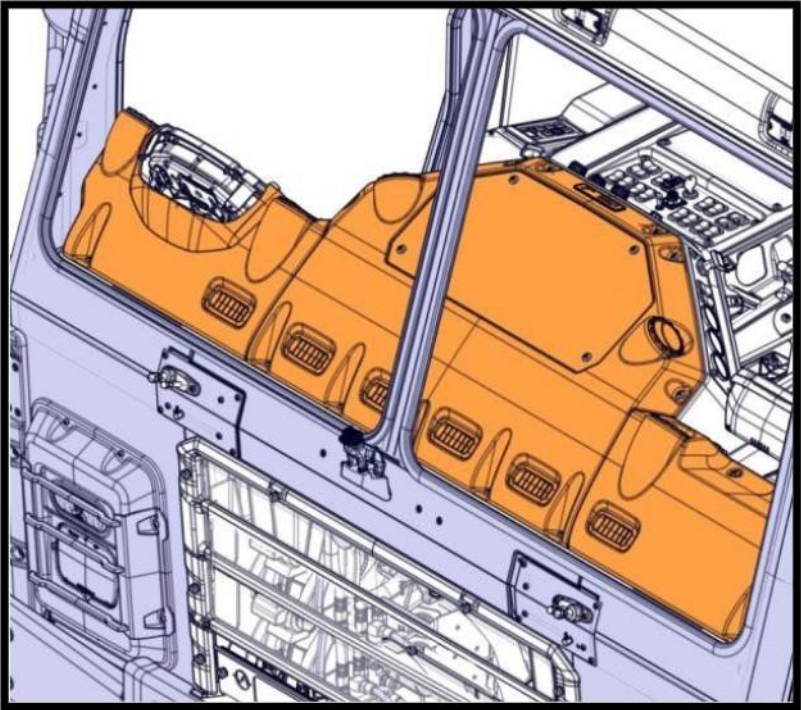

- 43. Install the A-pillar trim panel.
- 44. Install the handle.

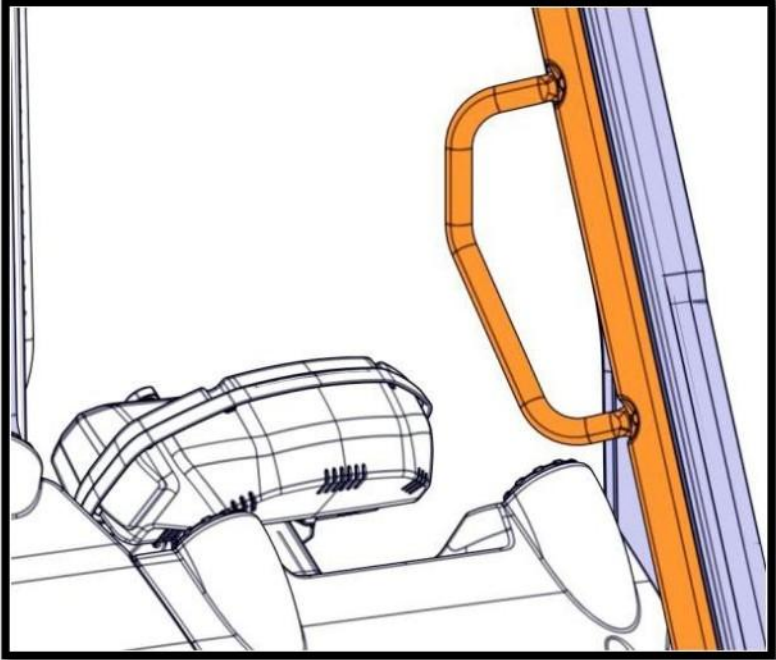

- 45. Install the A-pillar trim panel.
- 46. Install the handle.

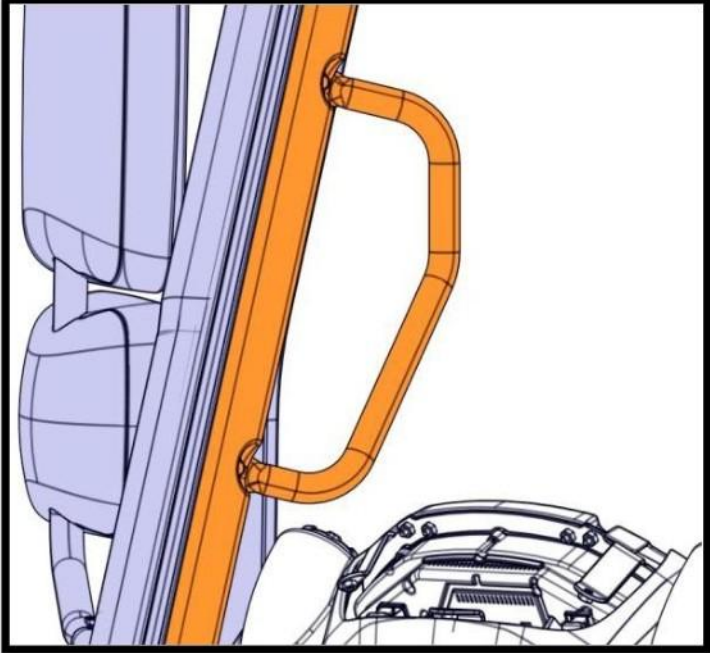

- 47. Install the bezel.
- 48. Install the screws.

49. Tighten the screws to torque.

Tightening torque	
Bezel, screw	$3 \pm 0.5 \text{ Nm}$ ( $2 \pm 0.4 \text{ lbf} \cdot \text{ft}$ )

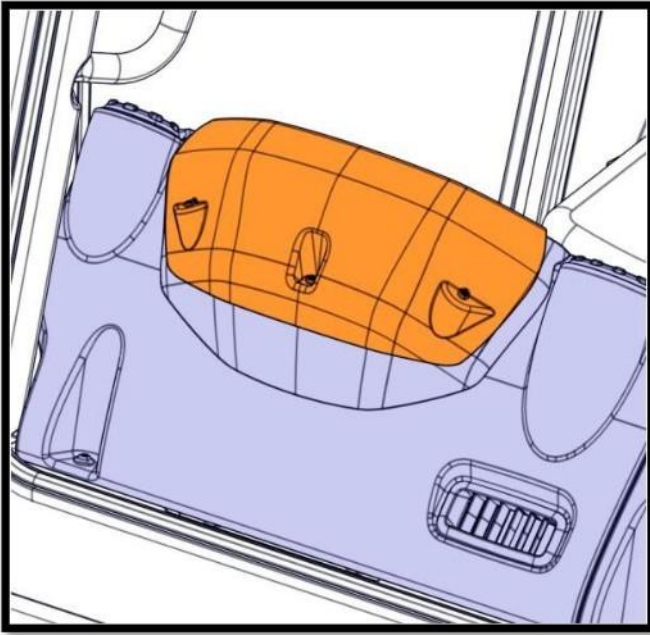

50. Install the trim panel.

51. Install the screws.

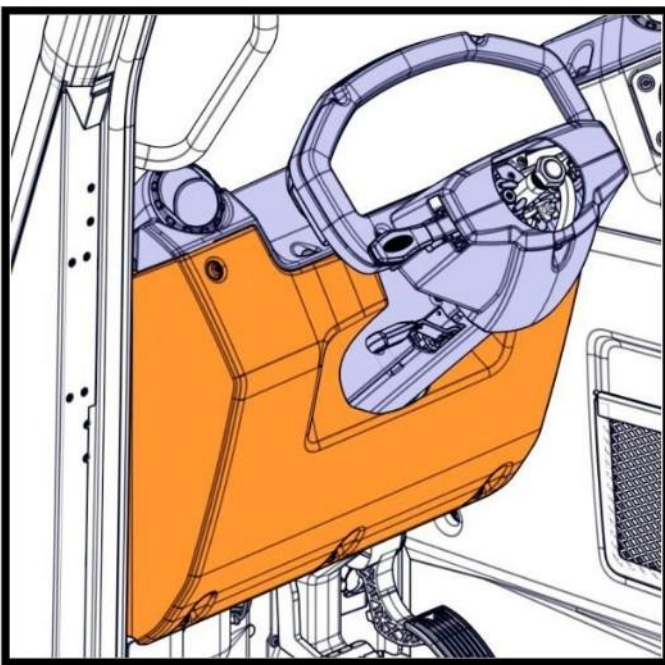

52. Tighten the screws to torque.

Tightening torque	
Panel, screw	$10 \pm 1.5 \text{ Nm}$ ( $7 \pm 1 \text{ lbf} \cdot \text{ft}$ )



- 53. Install the steering wheel.
- 54. Install the nut.
- 55. Torque tighten the nut.

Tightening torque	
Steering wheel, nut	68 ±5 Nm (50 ±4 lb( ft)

	Note Hand tighten only.
	Note Do not use impact tools.

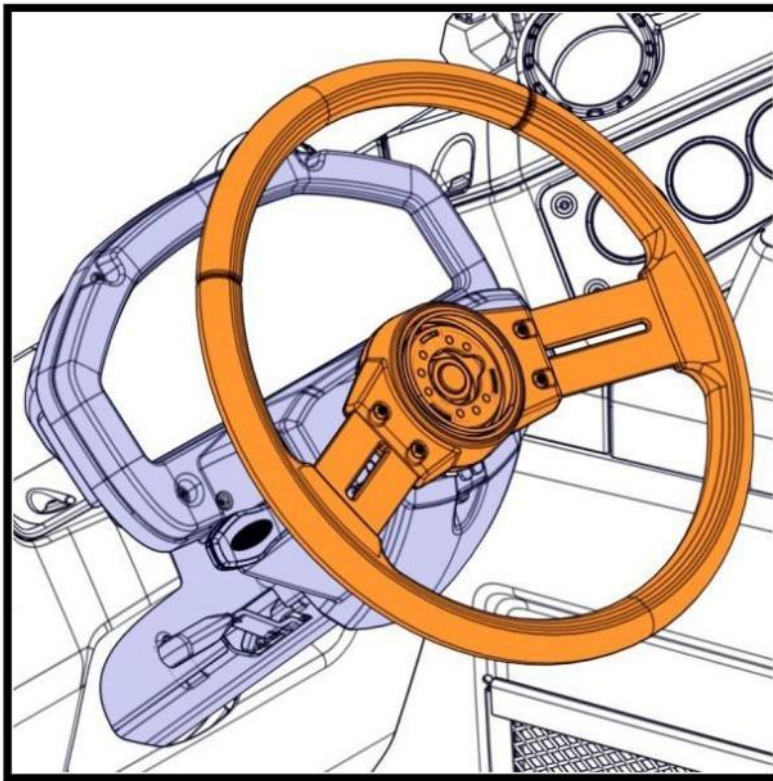

56. Install the horn button.

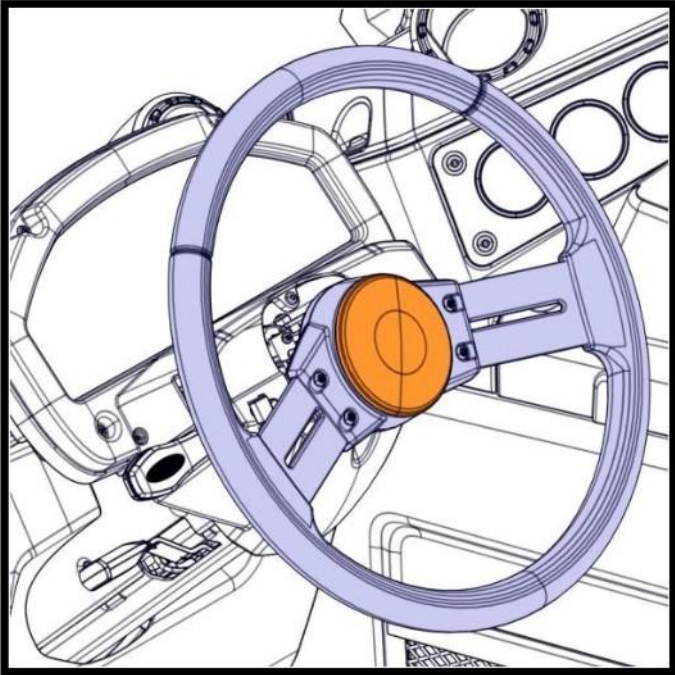

57. Install the bezel.

58. Install the screws.

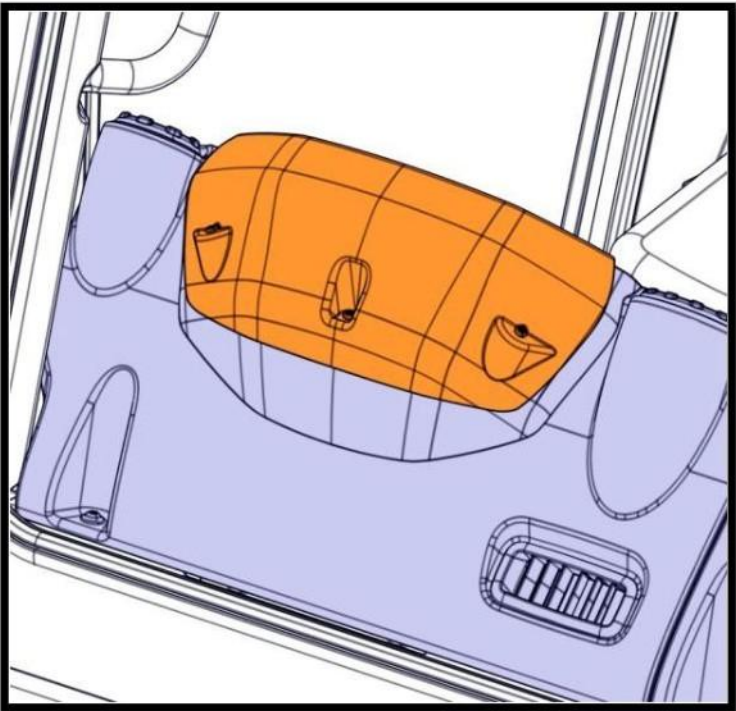

59. Tighten the screws to torque.

Tightening torque	
Bezel, screw	3 ±0.5 Nm (2 ±0.4 lb( ft)



- 60. Install the steering wheel.
- 61. Install the nut.
- 62. Torque tighten the nut.

Tightening torque	
Steering wheel, nut	68 ±5 Nm (50 ±4 lb( ft)

	Note Hand tighten only.
	Note Do not use impact tools.

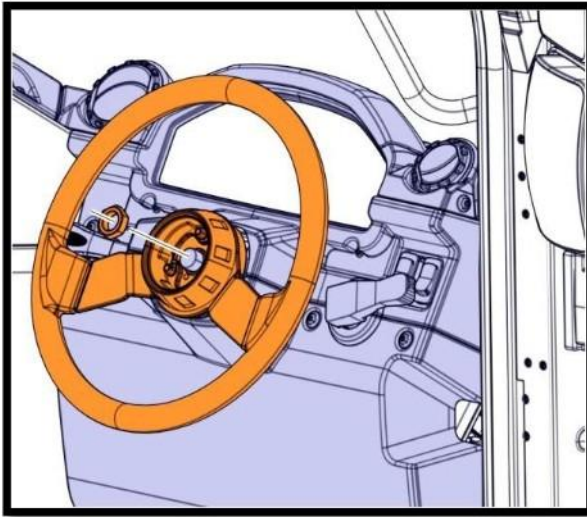

- 63. Install the horn button.

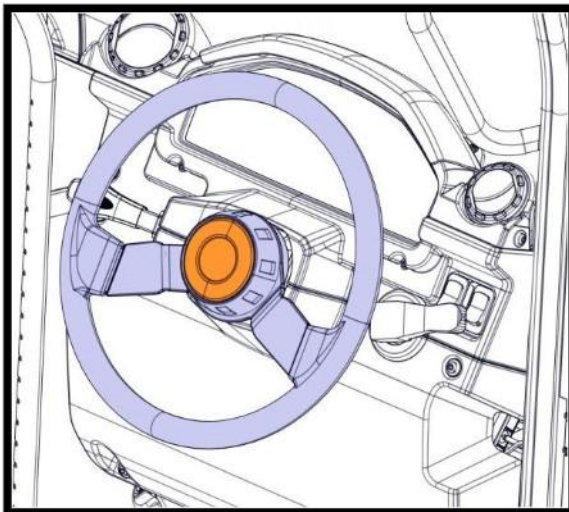

	<b>WARNING</b>
Risk of serious injury. Heavy component.	
▶ Exercise caution when moving the component. Assistance is required.	

64. Install the windshields.

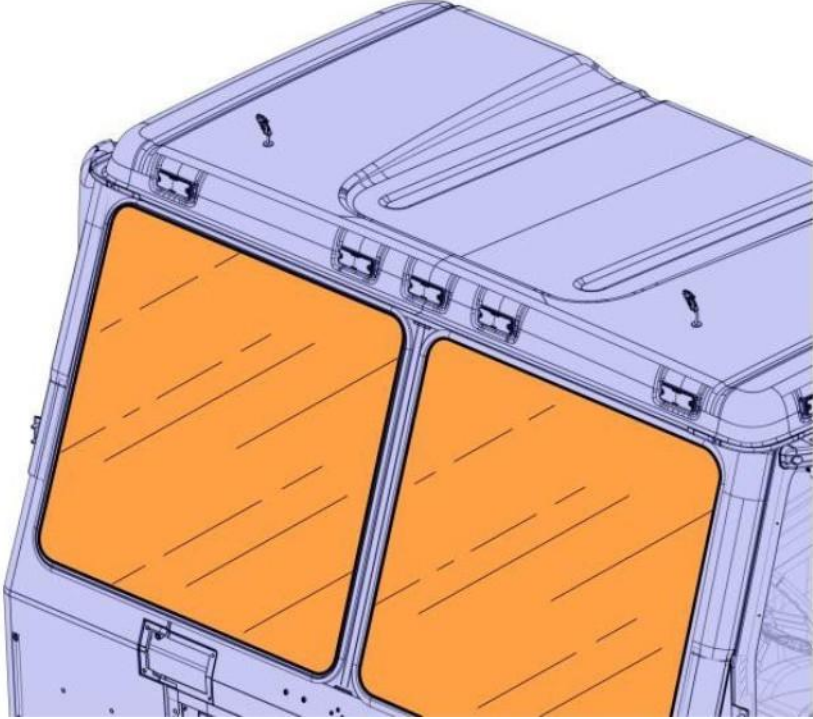

65. Install the wiper arms.

66. Install the nuts (1).

67. Tighten the nuts to torque.

Tightening torque	
Wiper arm, nut	10 ±2.4 Nm (7 ±2 lb{ ft)

68. Install the nuts (2).

69. Tighten the nuts to torque.

Tightening torque	
Wiper arm, nut	3.9 ±0.5 Nm (3 ±0.4 lb{ ft)

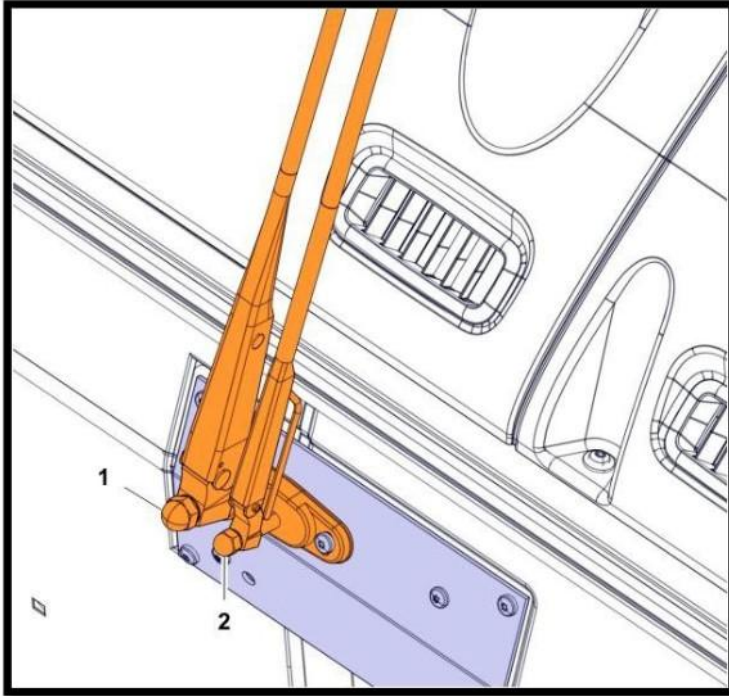

70. Connect the battery cable to negative (ground) terminal.

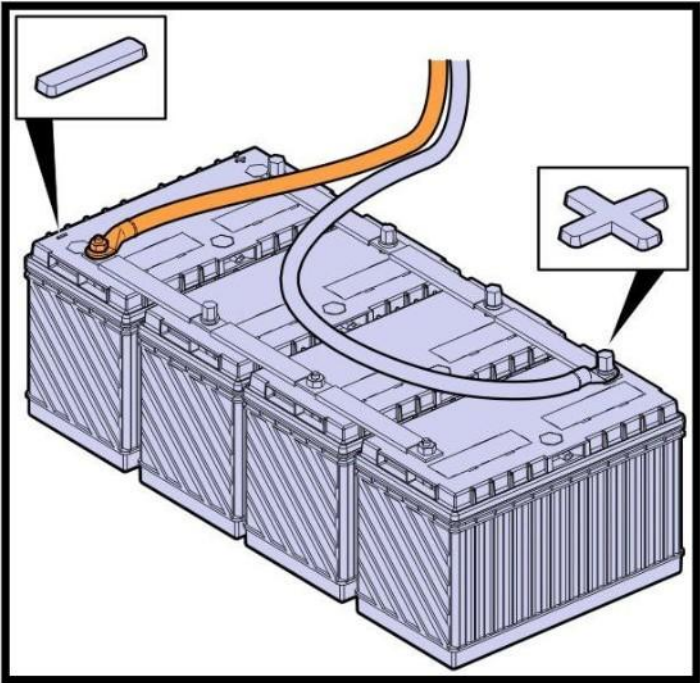

71. Remove the wheel chocks.

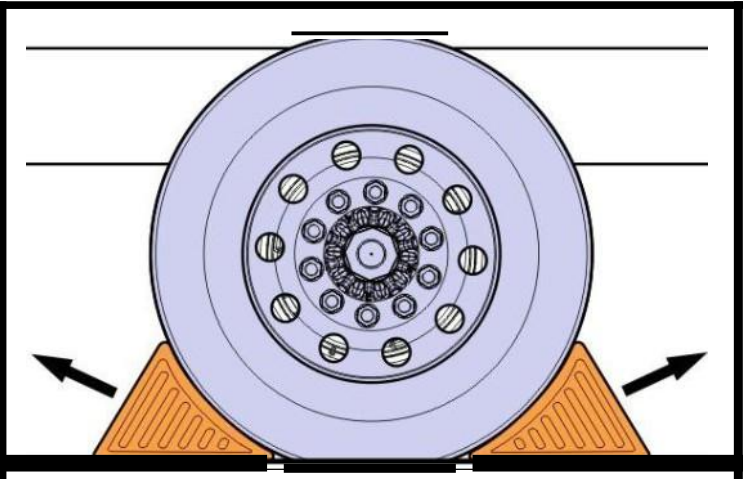

## COMPLETION LABEL

### NOTE

A campaign completion label (part number 85152363) needs to be installed on truck if not previously installed. To signify the campaign has been completed, use a permanent marker (Such as a Sharpe®) to write the recall number, completion date (MM/DD/YYYY) and dealercode on the label. The label is to be applied to the inside of the passenger door as shown in the illustrations below

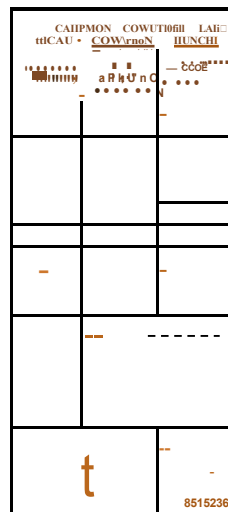

### Label Placement- Cabover Chassis Configuration

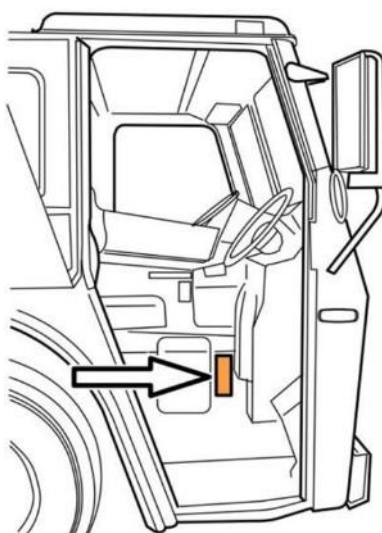

Dual steering wheels

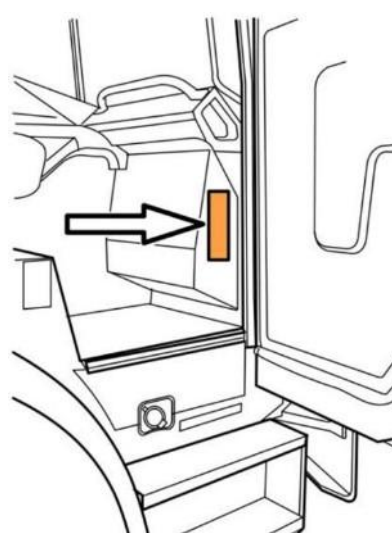

Single left side steering wheel

## REIMBURSEMENT

This repair is covered by an authorized Safety Recall Campaign. Reimbursement is obtained through the normal claim handling process.	
	<b>UCHP Reimbursement</b>
<b>Claim Type</b> (used only when uploading from the Dealer Business System)	40
<b>Recall Status</b>	
Vehicle repaired per instructions	1-Modified per instructions
<b>Labor Codes</b>	
<b>Inspection Only</b> 1720-16-09-01 - Campaign, General	0.1 x 15 for total of 1.5 hrs
<b>OR</b>	
<b>Inspection and Replacement</b> 1720-16-09-01 - Campaign, General	0.1 x 36 for total of 3.6 hrs
<b>Causal Part</b>	84726804
<b>Authorization Number</b>	C6625

**Note:** Dealers are to perform Safety Recall Campaign on all subject vehicles at no charge to the vehicle owner regardless of mileage, age of vehicle or ownership (original purchaser or subsequent purchasers). Whenever vehicles are subject to a Safety Recall Campaign are brought to your dealership for service, or taken into your dealership vehicle inventory, it is strongly recommended that every effort be made to perform the recall correction before the vehicle is sold or released to the owner.