



FIELD KIT

Vermeer Corporation

Environmental
Pella, Iowa 50219 USA

FIELD CAMPAIGN KIT #:	IK004084 Rev. 2	DATE:	16 February 2023
<i>For Dealer Reference: Service Bulletin #: SVC2022-075 Rev. 2</i>			
Trailer Frame Reinforcement Kit			

CAMPAIGN TYPE:	Mandatory – Product Safety DEALER INSTALLATION ONLY
CAMPAIGN CATEGORY:	Kit and Bulletin

MACHINE/ ATTACHMEN TMODEL(S):	SERIAL NUMBERS:		
	Included	Excluded	Kit version
AX19	101 – 136	None	IK01
	137 – 219	206	IK02
	1001 – 1068	1020, 1026, 1044 – 1068	IK03
	228, 231, 249	None	IK04
	1044 – 1066	1045, 1048 – 1052, 1054 – 1059, 1063, 1065	IK05
	220 – 342	228, 231, 249	IK06



PRODUCT SAFETY RECALL

Purpose: Vermeer Corporation has decided that a defect that relates to motor vehicle safety exists in certain model year 2015 – 2021 Vermeer AX19 brush chipper trailers.

On June 17, 2021, Vermeer Corporation sent an interim notice regarding the above product safety recall. The final remedy kit is now available.

Trailer frame failure may occur. A crack(s) can develop in the trailer frame during brush chipping which can result in severe damage to the brush chipper. If a crack(s) develops and is not identified during the maintenance interval inspections, the frame can bend and/or distort resulting in loss of stability while towing.

Death or serious injury possible. When towing the brush chipper on public roadways, **death or serious injury** may result due to the loss of control of the brush chipper and towing vehicle. A frame failure may increase the risk of a crash. Property or equipment damage may also occur.

Immediate machine modifications required. IK00-4084 has been created to provide the necessary parts and instructions to replace the plate gusset. **This kit must be installed as soon as possible.**

Reason for revision 1: Kit instructions were revised to include information from interim kit (IK004078) and to provide more clarity on which welds can be repaired.

Reason for revision 2: Kit instructions were revised to include information for IK01 on trimming back DEF tank cover to avoid interference.

Special tools and conditions:

- Welder
- Spreader bar (see procedure 1, step 11)
- Suitable containers to drain hydraulic fluid and fuel
- Suitable cutting device

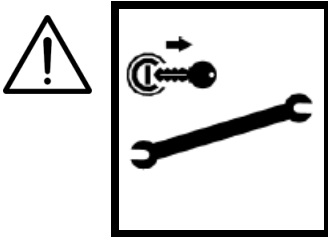

WARNING: Failure to use shutdown procedure can result in unexpected hazard(s). Death or serious injury could result due to entanglement, crushing, cutting or other hazardous contact. Follow shutdown procedure after operating, before performing any service or maintenance and before transporting.

Shutdown procedure

1. Move feed control bar to neutral position.
2. Reduce engine speed to low rpm.
NOTICE: Whenever practical and safe, allow engine to idle for one to five minutes before shutting down after operating at full power. Please consult machine's engine manual for details.
3. Wait for cutter drum to slow.
4. Place cutter drum (clutch) lever in the disengaged position.
5. Shut off remote control if in use.
6. Shut off engine and remove key.
7. Wait for cutter drum and belt to stop.

NOTICE: The cutter drum will continue to turn for a short time after disengagement. Check that cutter drum rotation has stopped by viewing drive sheave through screen (A) on drive belt shield.

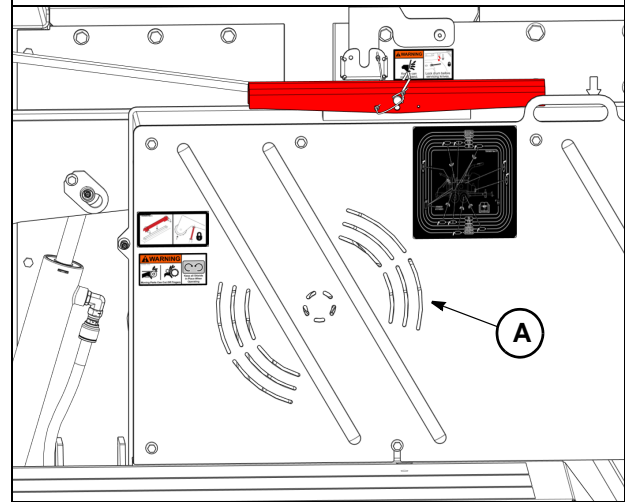
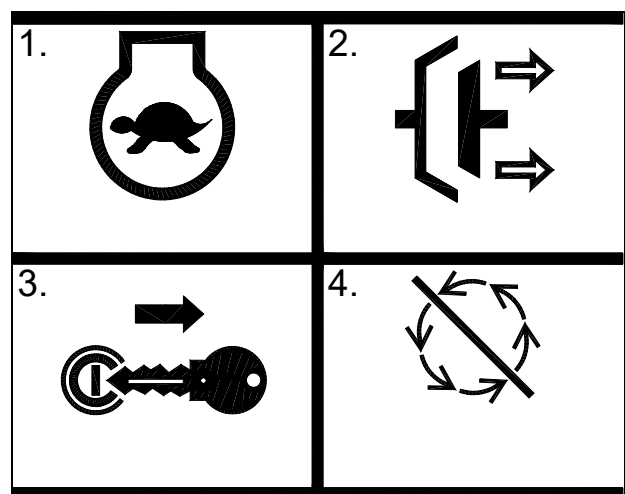

Welding precautions

Welding alert – electronic components

NOTICE: Welding will damage electronic components. Using battery disconnect switch to disconnect battery ground will not prevent damage.

To prevent damage to electronic modules and controllers, unplug them before welding. Observe the following precautions:

- Do not clamp welding ground to any electrical component.
- Clamp welding ground on the part being welded or as close to it as possible. Do not allow weld current to pass through bearings or other moving components.
- Thoroughly clean the welding location and remove paint.
- Protect wiring and wiring harness from weld spatter.
- Use proper welding procedures.

Do the following to prevent extensive and costly damage to the electrical components:

1. Disconnect battery terminals **(A)**. Refer to *Battery – replace* in the machine maintenance manual.
2. Open engine door and unplug harness connectors at ACS controller unit **(B)**.
3. Unplug harness connectors at engine controller **(C)**.
4. Unplug harness connector from DEF module **(D)**.
5. Locate and unplug harness connector to DEF tank sensor on top of DEF tank **(E)**.
6. Disconnect telematics control unit **(F)**.

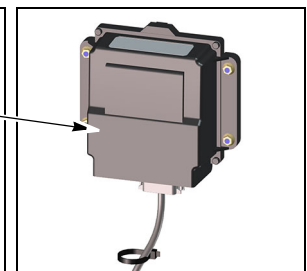
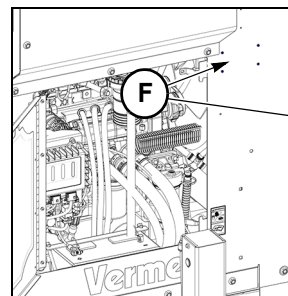
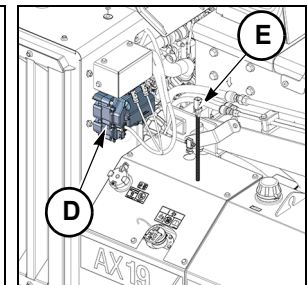
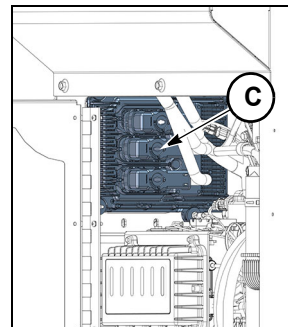
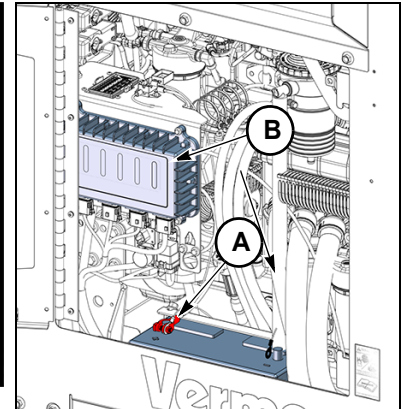
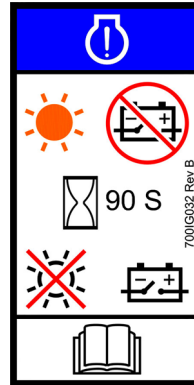
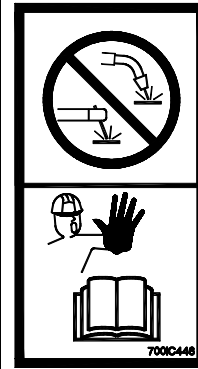

Vermeer Corporation weld repair instructions

Scope:

These welding instructions are intended for repair of a partially cracked AX19 frame.

Work area preparation and safety:

The company performing the welding is responsible for supplying the appropriate protective equipment, complying with the appropriate safety regulations (e.g., ANSI Z49.1) and taking appropriate measures to protect their personnel in the welding environment. Further, they are responsible for protecting sensitive equipment and components from the hazards of welding (e.g., shielding electronics, paint, plastics, etc, from the heat, light and sparks of arc welding). Follow the battery and/or controller disconnection specifications in the machine service manual. Disassemble the machine as much as necessary to provide adequate access to the repair areas.

Certifications:

All welding shall be performed by a welder qualified in the position and process used in AWS D14.3/D14.3M, *Specification for Welding, Earthmoving, Construction, and Agriculture Equipment* or one of the following: AWS B2.1, AWS D1.1, ASME section IX, ISO 9606-1.

Work lead connection (grounding):

Welding or cutting work leads (commonly referred to as grounds or ground clamps) must be attached directly to the weldment being repaired/modified and as close to the point of welding or cutting as practical. Additionally, it must be firmly connected to bare metal (paint removal is usually necessary). In no case shall the ground path be allowed to pass through bearings, electronics, bolted connections or other sensitive components or connections.

Frame inspection flow chart:

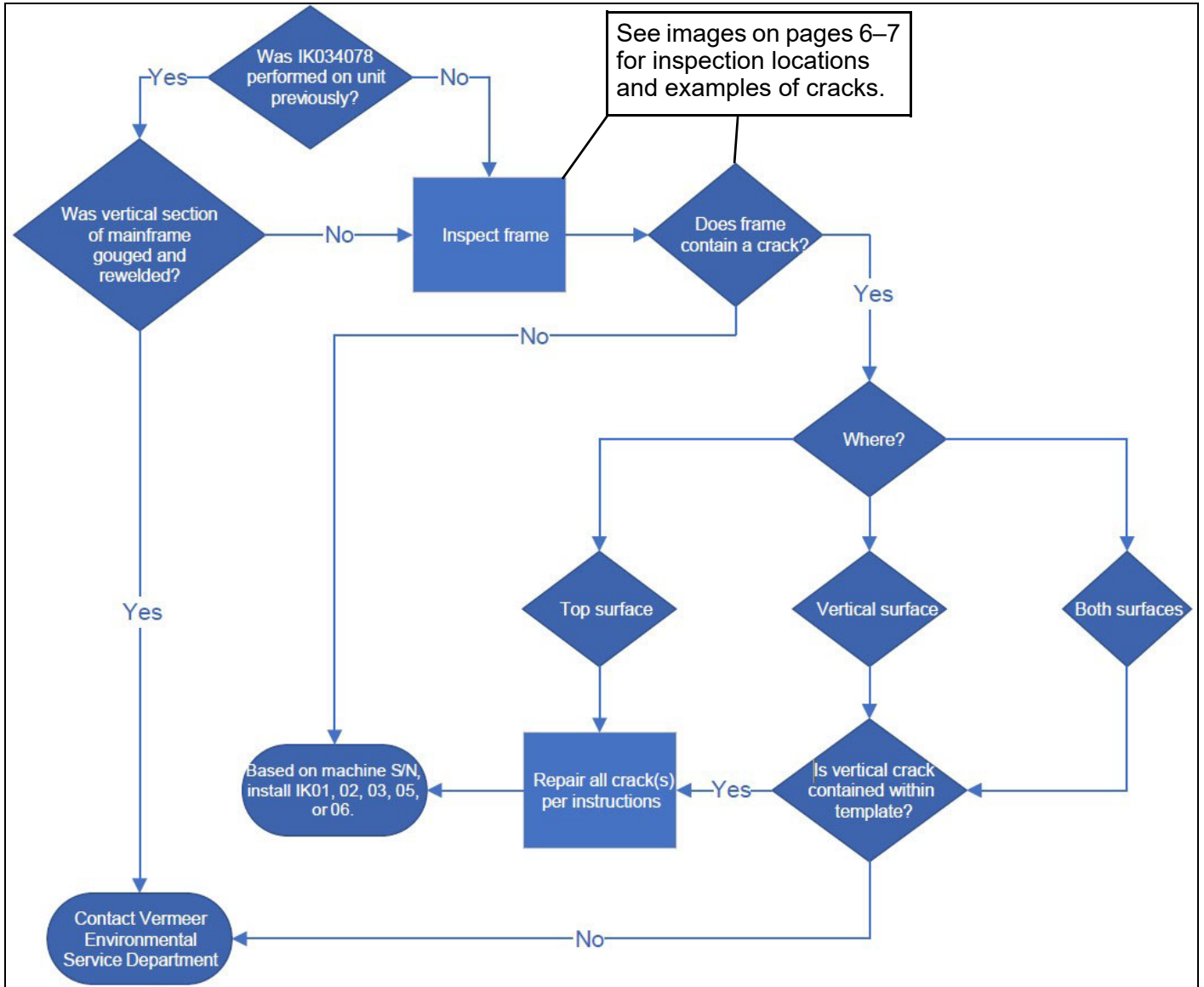

Frame inspection locations:

Left side:

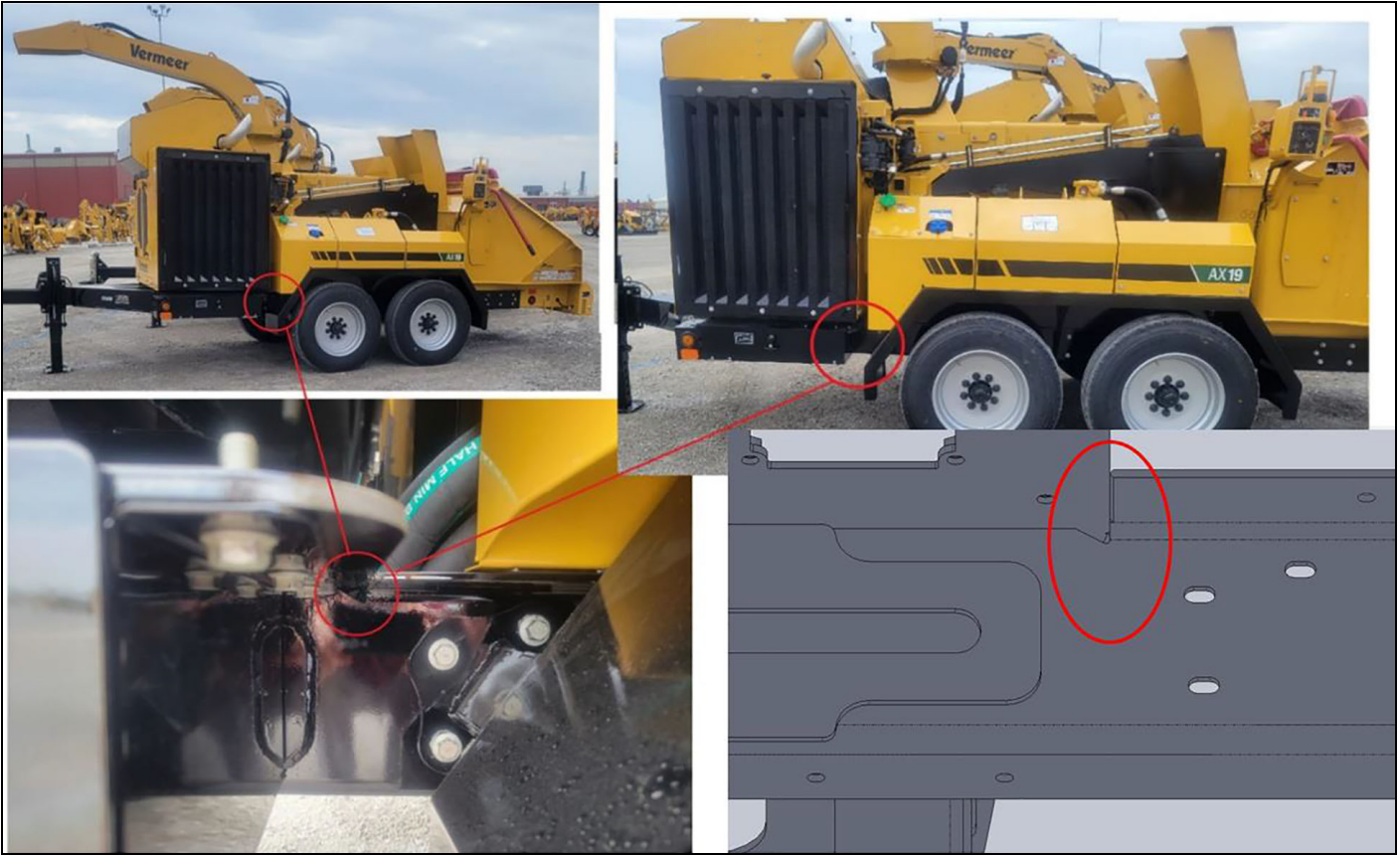

Right side:



Example: Top surface crack



Example: Vertical surface crack – contained within template (refer to template on next page)



Example: Vertical surface crack – not contained within template (refer to template on next page)



Repair instructions:

- 1. Removal of cracked welds:** Cut out any cracked welds in the designated areas. Carbon arc gouging or grinding may be used. Be careful not to remove more material than necessary.
- 2. Reinspect:** Reinspect to ensure the entirety of the crack(s) has been removed. Use the same inspection process (i.e., visual inspection, magnetic-particle testing and/or dye-penetrant testing). If any remaining crack is found, repeat step 1.
- 3. Prepare weld joints:** Grind (or cut) bevels in each joint to the dimensions in the figure below. Smoothly blend any notches or gouges in the base material. Clean all weld surfaces with a grinder. Surfaces within 0.5 in (12 mm) of weld locations shall be free from any material that will prevent proper welding. This includes moisture, loose or thick mill scale, paint, slag, heavy rust, grease, dirt or any other foreign material that will adversely affect the quality or strength of the weld.

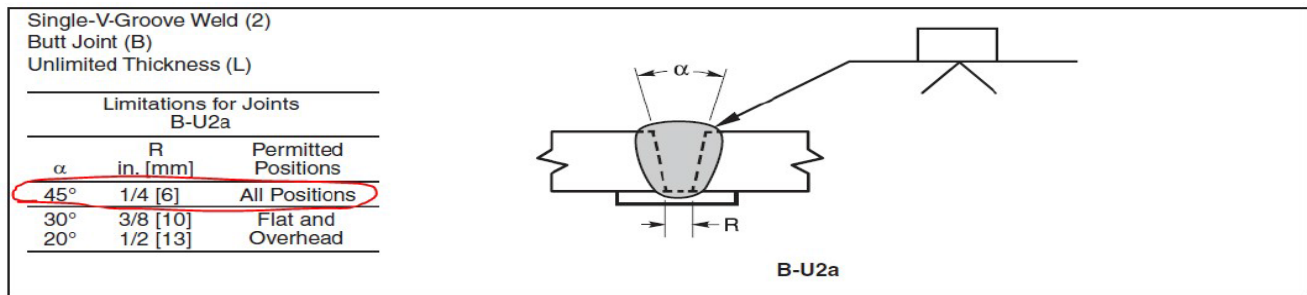
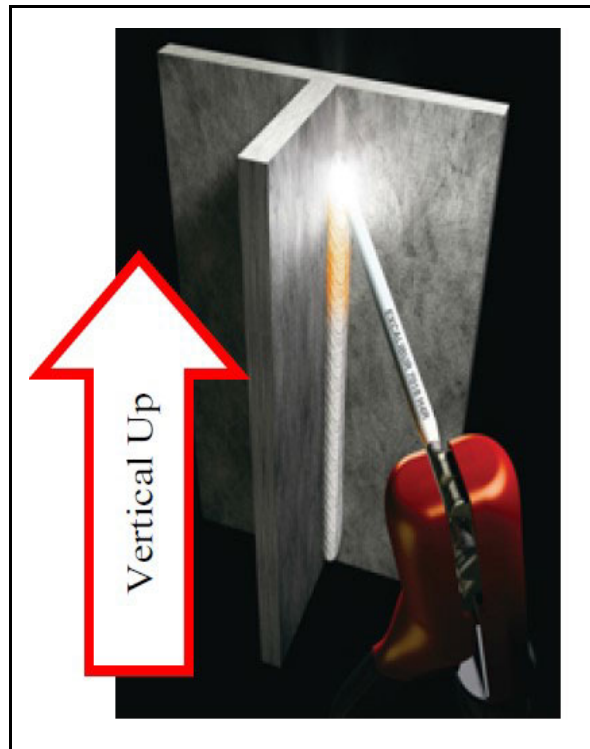

Figure A - Joint preparation and welding guide (source AWS D14.3:1010, Figure A.1)

- 4. Preheat:** The base metal within 3 in (76 mm) of the weld joint in all directions must be preheated to above 50°F (10°C) before welding or tacking. During welding, the base metal temperature must be maintained above 50°F (10°C) but below 500°F (260°C).
- 5. Attach backing:** Pull together or otherwise align parts as needed to match the dimensional requirements in Figure A. Tack in place backing strips as shown in Figure A. Use 0.25 in (6 mm) mild steel material (e.g., 1018 or A36). For welding, use one of the weld processes listed on page 10 (GMAW, FCAW or SMAW).

6. **Weld:** Select one (or more) of the weld processes listed below. Fill the groove welds and place fillet welds around the perimeter of the backing where possible. For FCAW and SMAW welding processes, remove all slag in between passes/layers. All grooves must be filled flush or slightly convex, as required in the quality acceptance criteria on page 7. All vertical welds must be made in a vertical up progression (see figure below).



7. **Inspect:** Inspect all welds in accordance with the weld quality acceptance criteria list on page 7. Repair any defective welds and reinspect. If defects (no go) are found, remove and repair them using one of the weld processes listed in this document.

Weld parameters for gas metal arc welding [GMAW/MIG/MAG]:

Environment: This process shall only be used when welding can be performed in a shop environment and only for the weld joints which can be positioned in the flat or horizontal positions. For vertical or overhead welding, FCAW or SMAW is recommended.

Electrode: AWS classification ER70S-3 or ER70S-6 (ER48-S6) (e.g., Lincoln L5 or L56)

Size: 0.145 in (1.2 mm)

Wire feed speed: Minimum 430 IPM (10.9 MPM) – maximum 520 IPM (13.2 MPM) [optimum 450 IPM (11.4 MPM)]

Voltage: Minimum 26 volts – maximum 30 volts (optimum 27.5 volts)

Amperage: Amperage is a function of wire feed speed, but should read in the range of 340 - 370.

Electrode stickout: 0.5 in – 0.75 in (12 mm – 20 mm)

Shielding gas: 95% argon – 5% oxygen or 90% argon – 10% CO₂ at 40 cfh (1.1 cmh)

Position: All welding should be in the flat or horizontal position. Vertical welding shall be uphill. No downhill welding is permissible.

Weld parameters for flux core arc welding [FCAW]

Environment: Protect the weld area from wind and moisture.

Electrode: AWS classification E71T-1M (E491T-1M) (e.g., Lincoln Ultracore 71A85)

Size: 0.052 in (1.3 mm) or 0.063 in (1.6 mm)

Wire feed speed: Minimum 200 IPM (5.1 MPM) – maximum 500 IPM (12.7 MPM) [optimum 450 IPM (11.4 MPM)]

Voltage: Minimum 23 volts – maximum 30 volts

Amperage: Amperage is a function of wire feed speed, but should read in the range of 220 - 370.

Electrode stickout: 0.75 in – 1 in (20 mm – 25 mm)

Shielding gas: See electrode manufacturer recommendation [usually 75Ar/25CO₂ @ 40 cfh (1.1 cmh)]

Position: Flat, horizontal, vertical and overhead positions are permissible. Vertical welding shall be uphill. No downhill welding is permissible.

Weld parameters for shielded metal arc welding [SMAW/MMA]:

Environment: Protect the weld area from wind and moisture.

Electrode: AWS classification E7018 (E4918) or equivalent

Size: 0.125 in (3.2 mm) or 0.156 in (1.0 mm)

Polarity: Direct current electrode positive

Amperage: 110 – 135 amps for 0.125 in (3.2 mm) and 125 – 200 amps for 0.156 in (4.0 mm)

Position: Flat, horizontal, vertical and overhead positions are permissible. Vertical welding shall be uphill. No downhill welding is permissible.

Electrode condition:

- All electrodes shall conform to AWS specification A5.1 and should be purchased in hermetically-sealed containers or should be baked by the user in an oven for one hour between 500°F and 800°F (260°C and 430°C) prior to use.
- Immediately after opening the hermetically-sealed container, electrodes should be stored in ovens held at a temperature of at least 250°F (120°C).
- After hermetically-sealed containers are opened or after electrodes are removed from baking or storage ovens, the electrode exposure to the atmosphere should not exceed four hours. If electrodes have been exposed to the atmosphere for more than four hours, they shall be rebaked in an oven for one hour between 500°F and 800°F (260°C and 430°C).
- Electrodes should be rebaked no more than one time.
- Electrodes that have been wet shall not be used.





Limitations:

These welding instructions are intended for use only as directed by Vermeer Corporation.

Weld quality acceptance criteria:

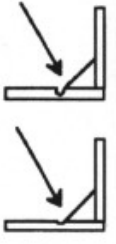
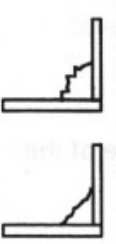
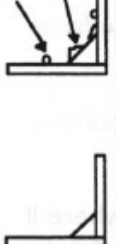
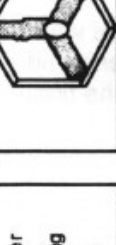
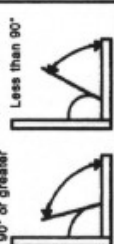
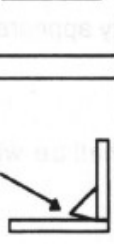
All welding shall be in accordance with the figure below. Any welds that do not conform (no go) must be repaired to bring them back into compliance (go). It is the responsibility of the company performing the repair to inspect the welds and ensure they meet these quality requirements.

Figure 4.4 Weld Quality Acceptance Criteria

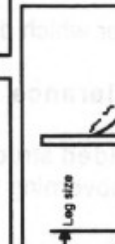
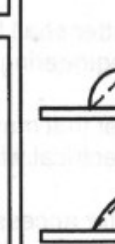
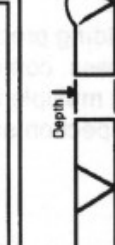
 <p>GO NO GO UNDERCUT</p> <p>Undercut in excess of 1/32" is unacceptable. The "No Go" example is just beyond 1/32".</p>	 <p>GO NO GO ROUGHNESS</p> <p>If the profile is very uneven or if the size varies a lot, the weld is too rough.</p>	 <p>GO NO GO CLEANING</p> <p>The cleaning example on the right is shown as "Go/No Go" because internal standards set different limits of what is acceptable depending on the function of the part. In most cases spatter is unacceptable.</p>	 <p>GO NO GO TIE-IN</p> <p>A tie-in should blend all intersecting welds together smoothly. The welds must be within size limits, and tie-ins must meet all other external weld characteristic requirements.</p>
 <p>GO NO GO OVERLAP</p> <p>When the angle at the toe of the weld, between the weld metal and the base metal, is less than 90°, the weld is unacceptable.</p>	 <p>NO GO LACK OF FUSION</p> <p>Any lack of fusion is unacceptable. Therefore there isn't a "Go" example.</p>	 <p>GO NO GO CRATER FILL</p> <p>Craters usually occur where a weld stops and must be filled. This "Go" example has been correctly filled to 85% or more of the specified throat. This "No Go" example hasn't been filled enough.</p>	 <p>GO NO GO POROSITY</p> <ul style="list-style-type: none"> Pin holes larger than 1/16" diameter are unacceptable. More than 1 pore in any 3" of weld or 2 pore in any 12" of weld is unacceptable Cluster porosity is unacceptable.
 <p>GO NO GO FILLET SIZE</p> <ul style="list-style-type: none"> Both legs must be equal to the specified print size, minus 1/32", plus 1/8" maximum. No concavity is allowed. (Minimum throat size of 0.7 times the specified leg size produces a flat weld profile.) See ropiness table (at right) for convexity tolerance. 	 <p>GO NO GO ROPINESS (CONVEX FILLET WELDS)</p> <p>(Use a weld gage to check ropiness) The fillet weld throat that measures greater than the next larger size fillet weld gage is unacceptable.</p>	 <p>GO NO GO GROOVE SIZE</p> <p>If weld depth is: then max. concavity is: none</p> <p>2" or less over 2" 1/8" 3/16"</p>	 <p>NO GO CRACK</p> <p>Any crack is unacceptable. Therefore there isn't a "Go" example.</p>

*The word "example" always means the plastic examples not drawings. These examples relate only to external appearance! They do not necessarily indicate the structural strength of the weld.

➔ Unless indicated, new parts from kit have callouts with numbers. Callouts with letters indicate existing parts or general items.



WARNING: Raised load can shift or fall. Death or serious injury could be possible if struck or crushed by falling load. Never allow anyone under a raised load unless load is securely supported to prevent it from shifting or falling.

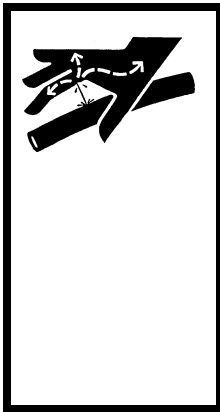

WARNING: Pressurized fluid can penetrate body tissue and result in death or serious injury. Leaks can be invisible. Keep away from any suspected leak. Relieve pressure in the hydraulic system before searching for leaks, disconnecting hoses or performing any other work on the system. If you must pressurize the system to find a suspected leak, use an object such as a piece of wood or cardboard rather than your hands. When loosening a fitting where some residual pressure may exist, slowly loosen the fitting until oil begins to leak. Wait for leaking to stop before disconnecting the fitting. Fluid injected under the skin must be removed immediately by a surgeon familiar with this type of injury.

Procedure 1: Installation of gussets (IK01, IK02, IK03 and IK06) and axle fasteners (IK03 and IK05 only)

1. Rotate discharge chute so that it won't be hit while removing engine bay.
2. Remove belt shield cover to get access to cutter drum drive belt.
3. Refer to *Cutter drum drive belt - replace* in machine maintenance manual for procedure to release tension on drive belt.
4. Remove sheave (A) from clutch.
5. Disconnect hose (B) from hydraulic tank (C), then refer to *Hydraulic fluid/filter/strainers - change/replace/clean* in machine maintenance manual for procedure to remove hydraulic tank.

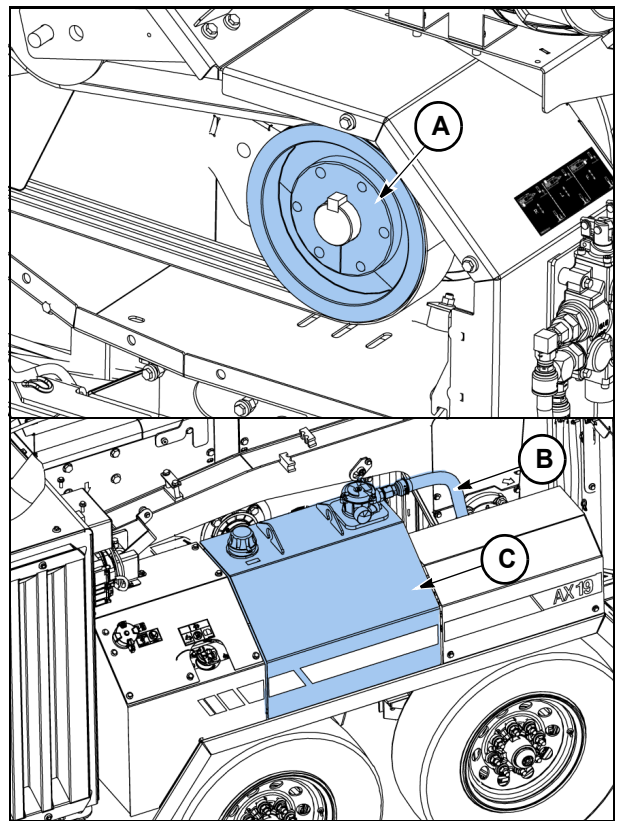

6. Remove and keep fasteners securing DEF tank (D) and hydraulic valve (E) to left-side fender.
7. Attach a suitable lifting device, then remove and keep screws (F) securing left-side fender to main frame. Support DEF tank and hydraulic valve in position when removing fender. Fender weighs 100 lb (50 kg).
8. Remove and keep screws (G) securing step to main frame.
9. Attach a suitable lifting device, then remove and keep screws (H) securing right-side fender to main frame and belt shield. Fender weighs 100 lb (50 kg).
10. Remove and keep screw (J) mounting tool box to main frame.
11. Use a suitable lifting device capable of 4,000 lb (2 000 kg) and attach to existing engine bay lift points (IK01) or install lift points (5) included with IK02, IK03 and IK04. Use existing engine bay screws to attach lift points.
 For serial numbers 1001 and up, the rear hood of the engine bay (K) will need to be removed to install the lift points.
 It is recommended to use a spreader bar to prevent damage to the engine shield. If your dealership does not have a spreader bar or means of lifting the engine shield without causing damage, contact environmental service to order part number 163821407 – LIFTING DEVICE – AX19 ENGINE POD. Expect a long lead time to receive this part.
12. Disconnect harnesses and hoses from engine and drain fluids into appropriate containers. Mark harnesses and hoses for ease of assembly later.

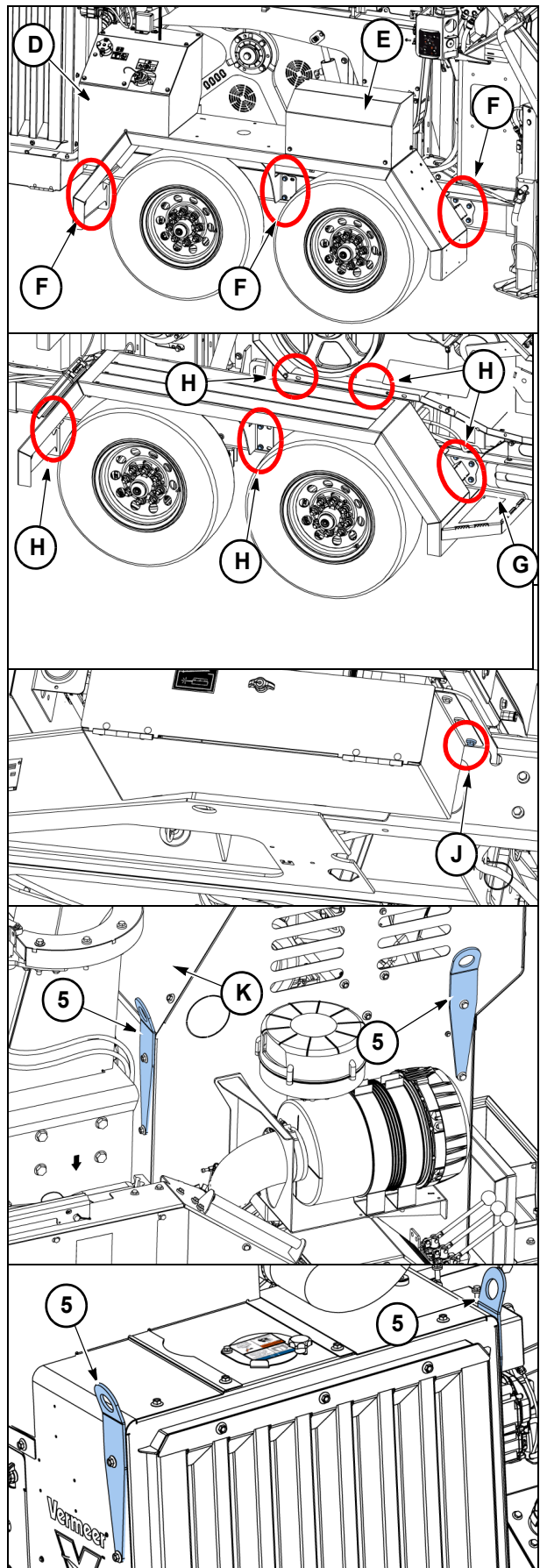

13. Remove and keep fasteners (K) securing engine bay to main frame then lift and remove engine bay.

14. Drain fuel tank and disconnect any hydraulic hoses that would get in the way during fuel tank removal. Mark hoses for ease of assembly later.

15. Remove fuel tank heat shield (L), then remove fuel tank. Fuel tank weighs 45 lb (20 kg).

16. Drill 1-in (25-mm) diameter hole in location shown on right and left side of main frame. Start with 0.25 in (6.4 mm) and work up to 1 in (25 mm).

17. Remove and discard chain links (M) and weldnut (N) from main frame.

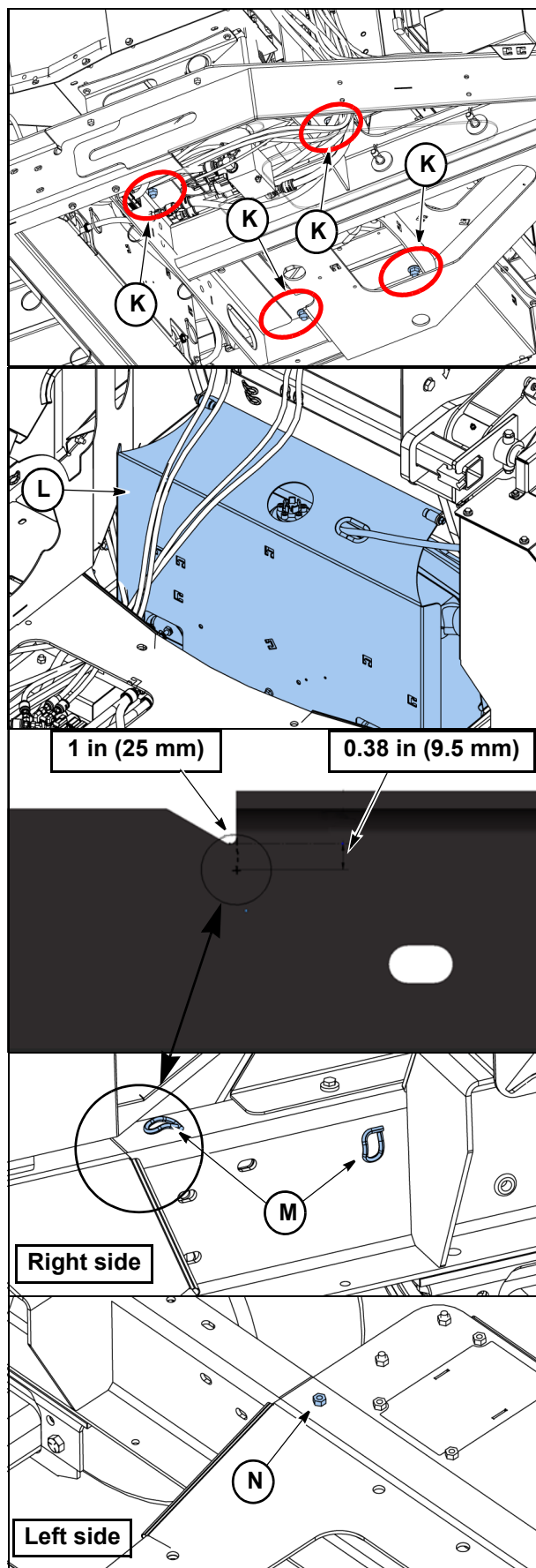

18. Remove paint from areas on main frame where left-hand gusset plate (1) and right-hand gusset plate (2) will be welded, then weld each plate per weld print 163800717 (see next page).
19. Weld new chain link (4) and new weldnut (3) into place. Refer to step 16.
20. Paint gusset and any areas damaged by welding.

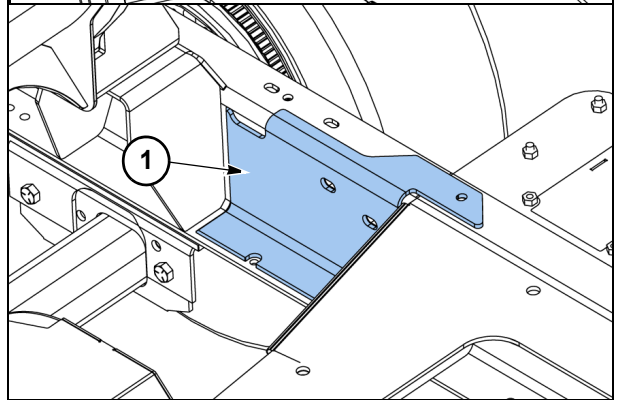
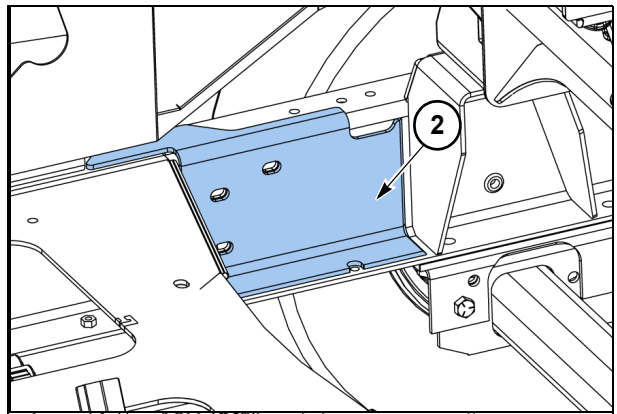

21. For IK03 and IK05: Remove axle mounting fasteners (screw, washers, spacer, nut) one set at a time and replace with new screw (7), washers (9), spacer (6) and nut (8). Repeat for seven remaining sets. Torque each screw to 196 ft-lb (266 Nm).

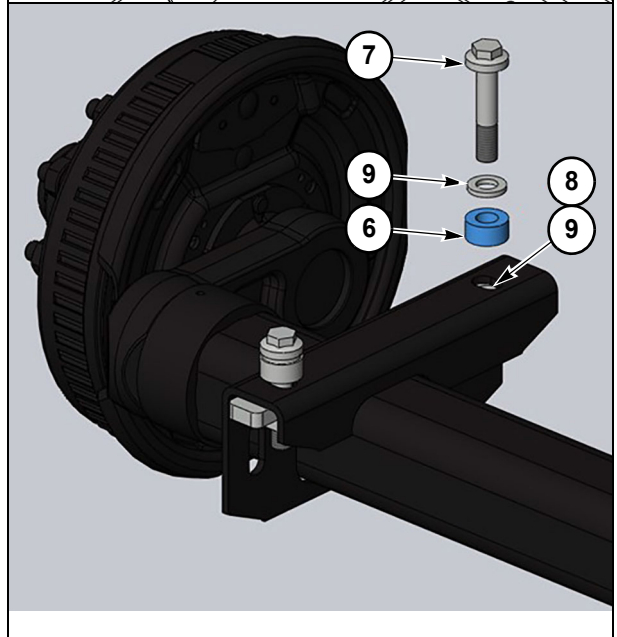

- 22. For IK01:** Before replacing DEF tank cover, trim back portion of flat surface that attaches to the frame as shown in dimensioned image. Paint reworked area if needed.
- 23.** Reverse steps 1 – 14 to install fuel tank, engine bay, fenders and hydraulic tank.
- 24.** Fill fuel tank and hydraulic tank.
- 25.** Operate machine and verify there are no hydraulic or fuel leaks.
- 26.** Remove Figures 1 – 4 and attach to invoice or place in manual storage box so unit owner can place with existing parts manual.

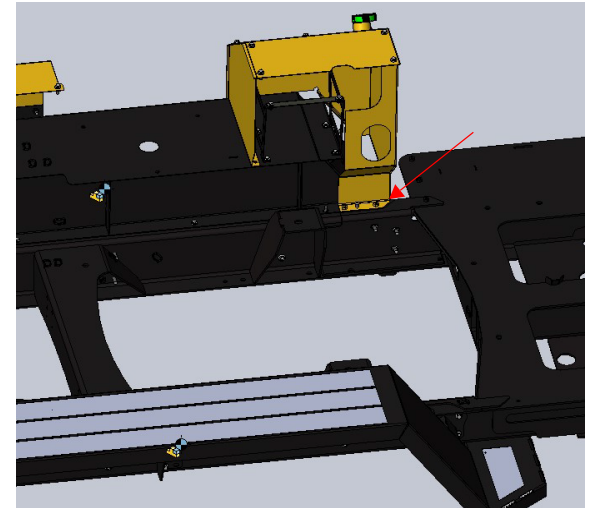
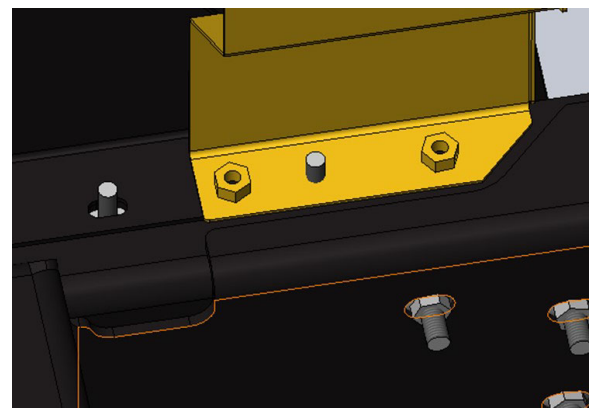
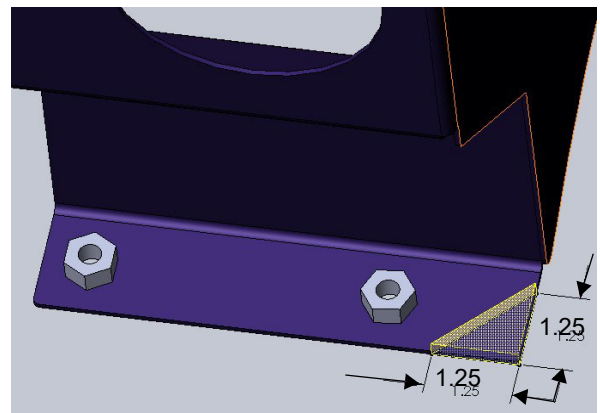

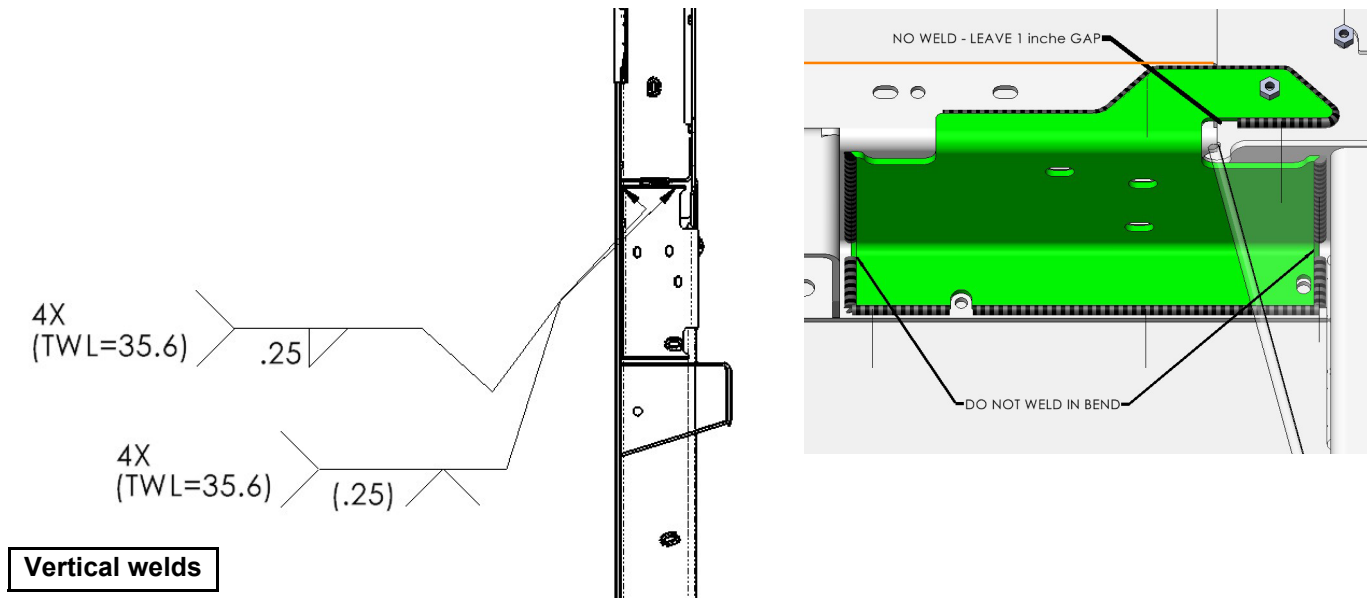
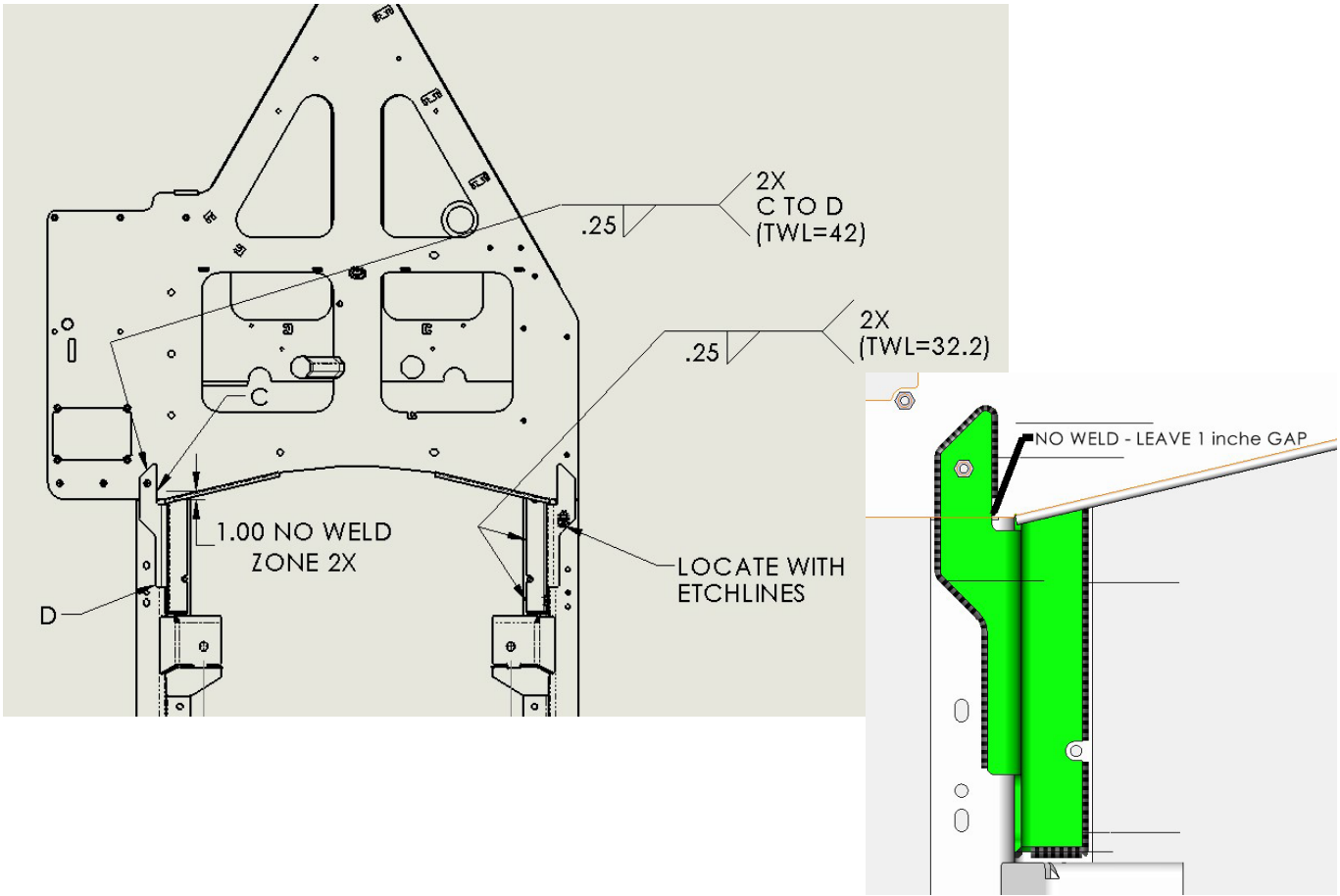

Procedure 2: Main frame replacement (IK04 only)

Use a lifting device capable of up to 4,000 lb (2 000 kg) for all assemblies being removed in this procedure.

1. Drain hydraulic tank and fuel tank. Refer to machine maintenance and/or service manual.
2. Disconnect battery. Refer to machine maintenance manual.
3. Disconnect wire harness from rear of machine, then remove control towers (A). Mark harness ends for ease of assembly later.
4. Disconnect hose (B) from hydraulic tank (C), then refer to *Hydraulic fluid/filter/strainers - change/replace/clean* in machine maintenance manual for procedure to remove hydraulic tank.
5. Remove DEF tank (D), feed arm position sensor (E) and hydraulic manifold (F) from left fender. Mark all hoses and harnesses for ease of assembly later.
6. Remove fenders from left side and right side of machine. Refer to procedure 1, steps 7 – 9.
7. Disconnect hoses from winch motor (G), then remove winch (H). Mark hoses for ease of assembly later.
8. Remove rear stabilizers (J).
Disconnect hoses (K) if equipped with hydraulic stabilizers, then remove stabilizers. Mark hoses for ease of assembly later.
9. Disconnect hoses from discharge neck/chute then remove discharge neck/chute. Mark hoses for ease of assembly later.

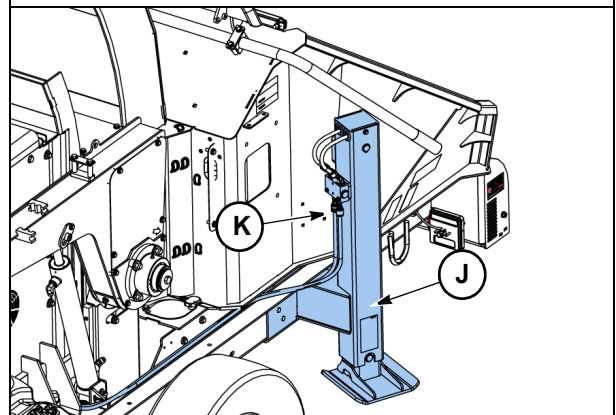
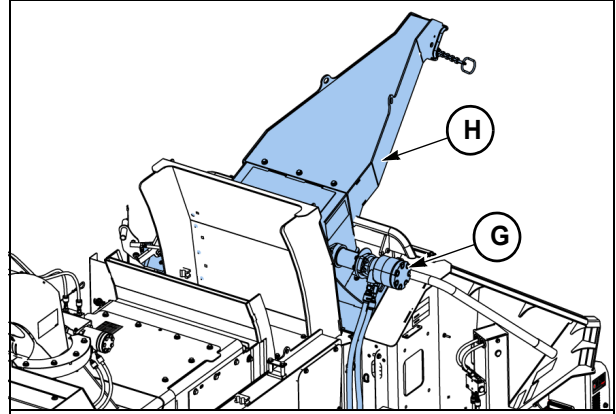
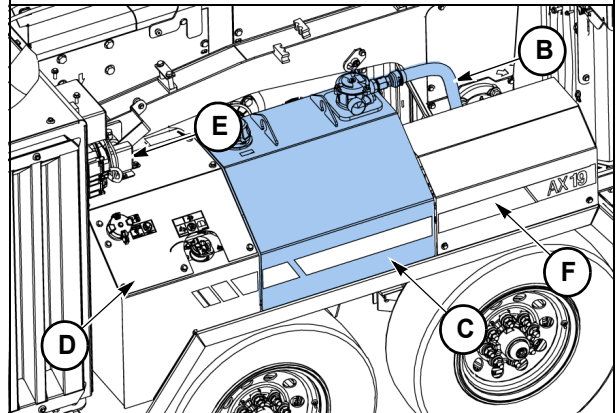
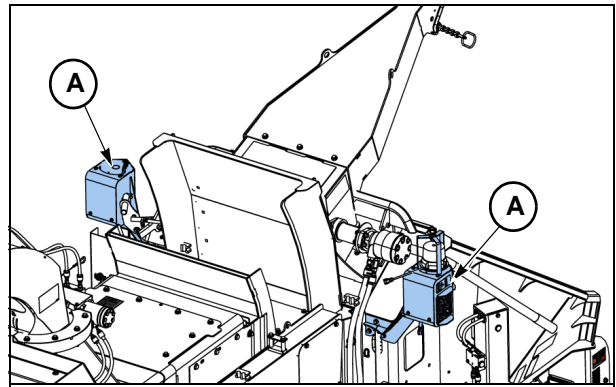

10. Remove infeed table (**L**). Mark any hoses or harnesses for ease of assembly later.

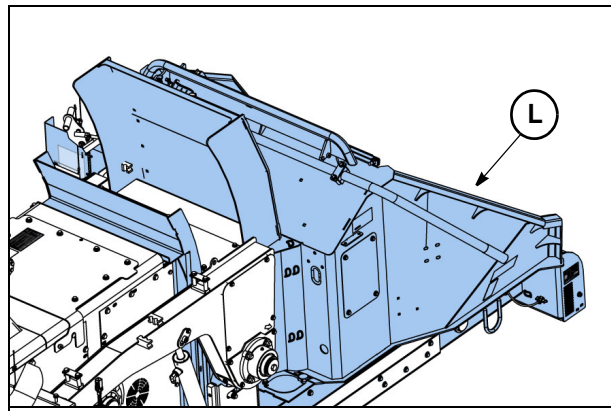

11. Remove cover (**M**) to get access to cutter drum drive belt.

12. Refer to *Cutter drum drive belt - replace* in machine maintenance manual for procedure to release tension on drive belt.

13. Remove drive belt and sheaves.

14. Disconnect hoses from control valve (**N**), then remove valve. Mark hose ends for ease of assembly later.

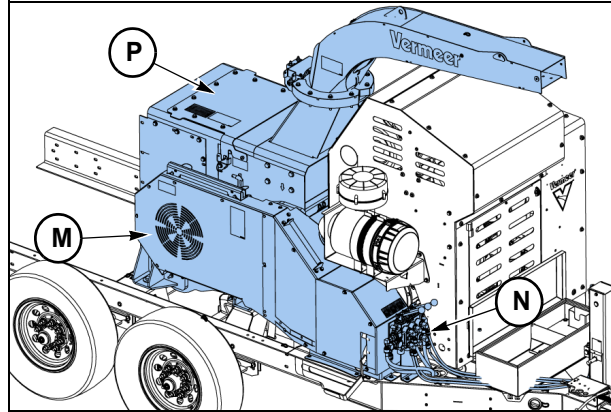

15. Remove drum and drum bearings, drum housing and discharge chute (**P**).

16. Remove engine bay (**Q**). Refer to procedure 1, steps 10 – 12.

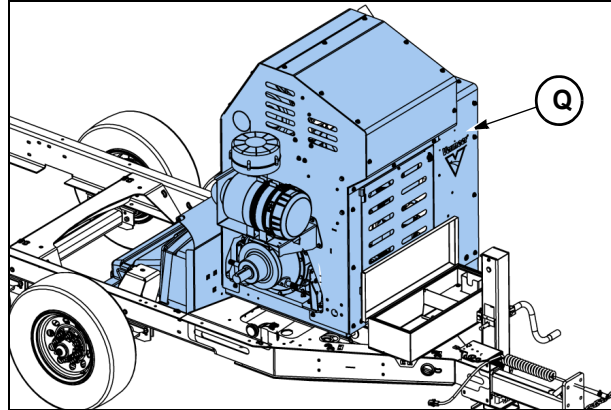

17. Remove fuel tank (**R**). Refer to procedure 1, steps 13 and 14.

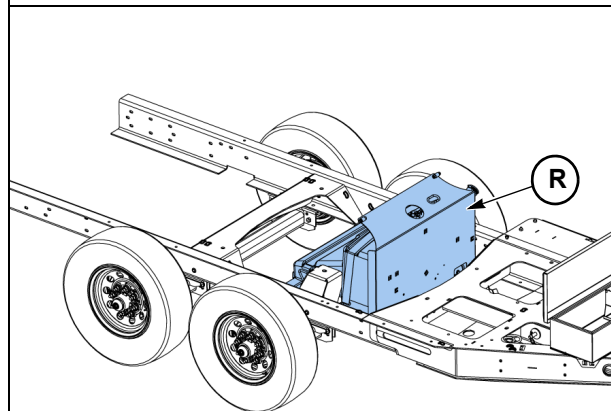

18. Remove one axle (**S**) with wheels from existing main frame, then install onto new main frame. Torque each screw to 196 ft-lb (266 Nm).

19. Remove second axle (**S**) from existing main frame, then install onto new main frame. Torque each screw to 196 ft-lb (266 Nm).

20. Remove tongue (**T**) from existing main frame and install onto new main frame.

21. Remove jack (**U**) from front of existing main frame and install onto new main frame.

Disconnect and mark hydraulic hoses if machine is equipped with a hydraulic jack.

22. Remove toolbox (**V**) from existing main frame.

23. Install toolbox onto new main frame with new door, latch and cover plate mount included in kit. Refer to Figure 4.

24. Reverse steps 1 – 21 to install remaining components onto new main frame.

25. Destroy old main frame by cutting through frame rails where they meet the top plate. Cut old VIN tag in half.

26. Proof of destruction of old main frame must be sent to productsafety@vermeer.com.

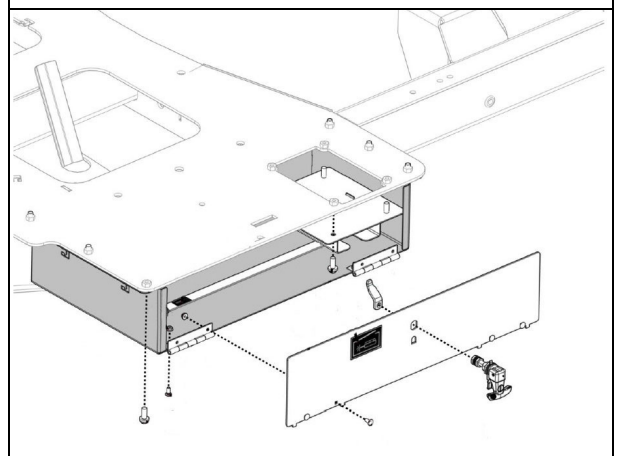
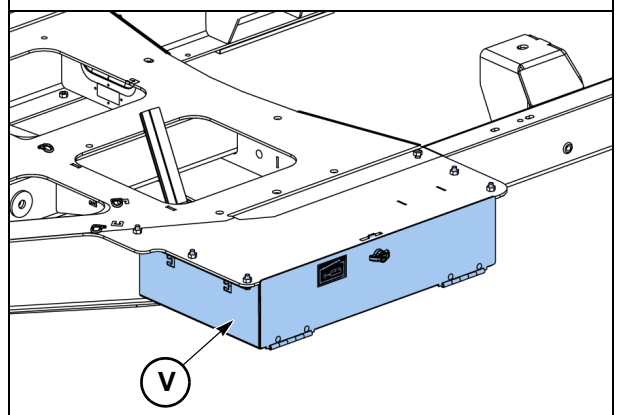
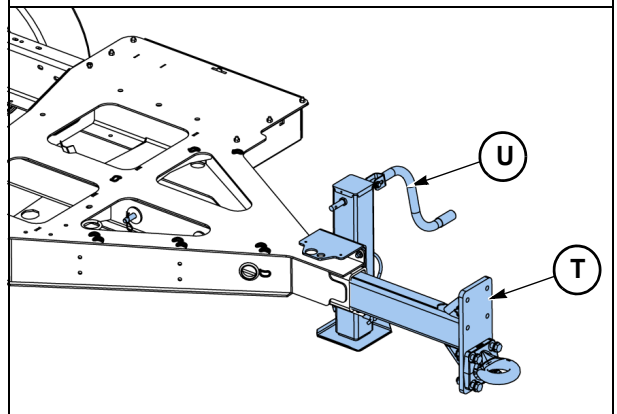
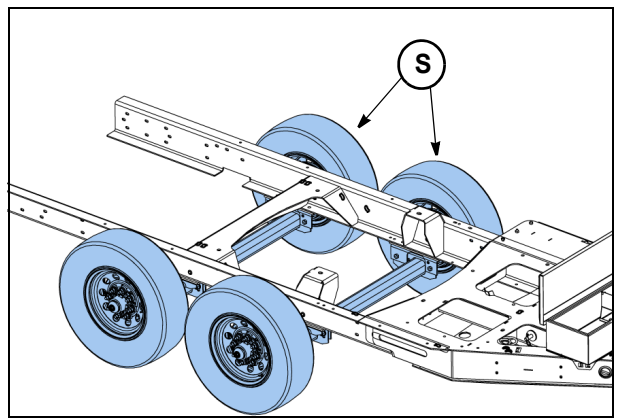

UNIT OWNER COPY
 Insert into parts manual
 for future reference.

Figure 1

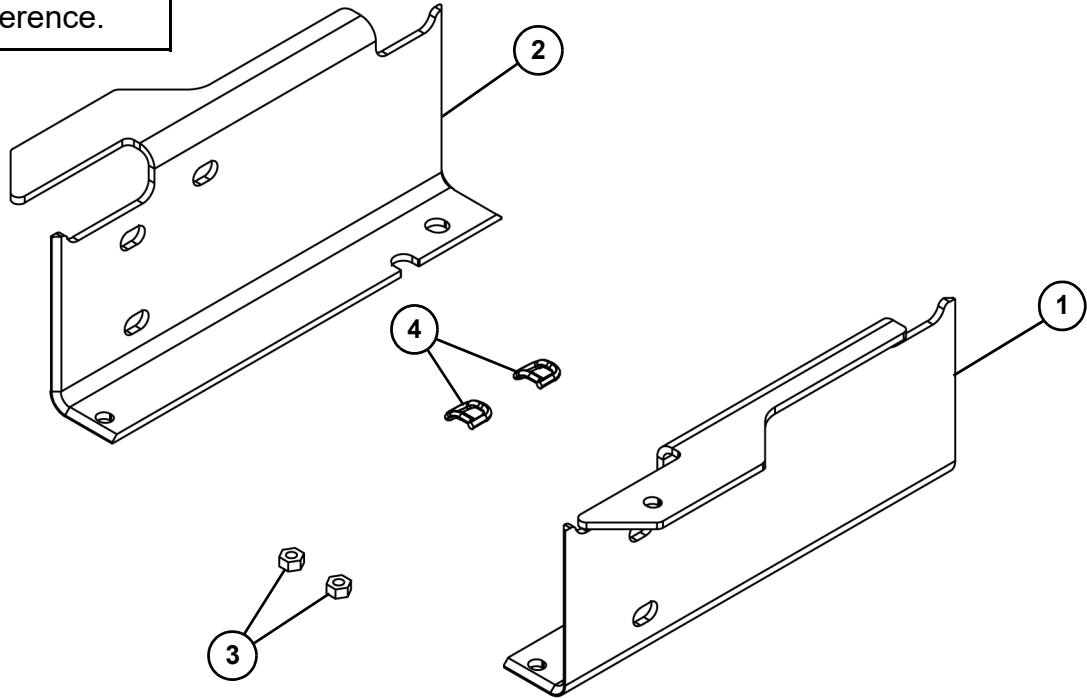

Figure 1 parts list

<u>REF. NO.</u>	<u>PART NO.</u>	<u>DESCRIPTION</u>	<u>IK01 QTY.</u>
1	163808188	PLATE – GUSSET	1
2	163808189	PLATE – GUSSET	1
3	508482010	NUT–HEXWELD, M10-1.50, DIN929	2
4	109430001	LINK–HARNES TIEDOWN	2
	IK01-4084	Kit includes all items in Figure 1 parts list.	

UNIT OWNER COPY
 Insert into parts manual
 for future reference.

Figure 2

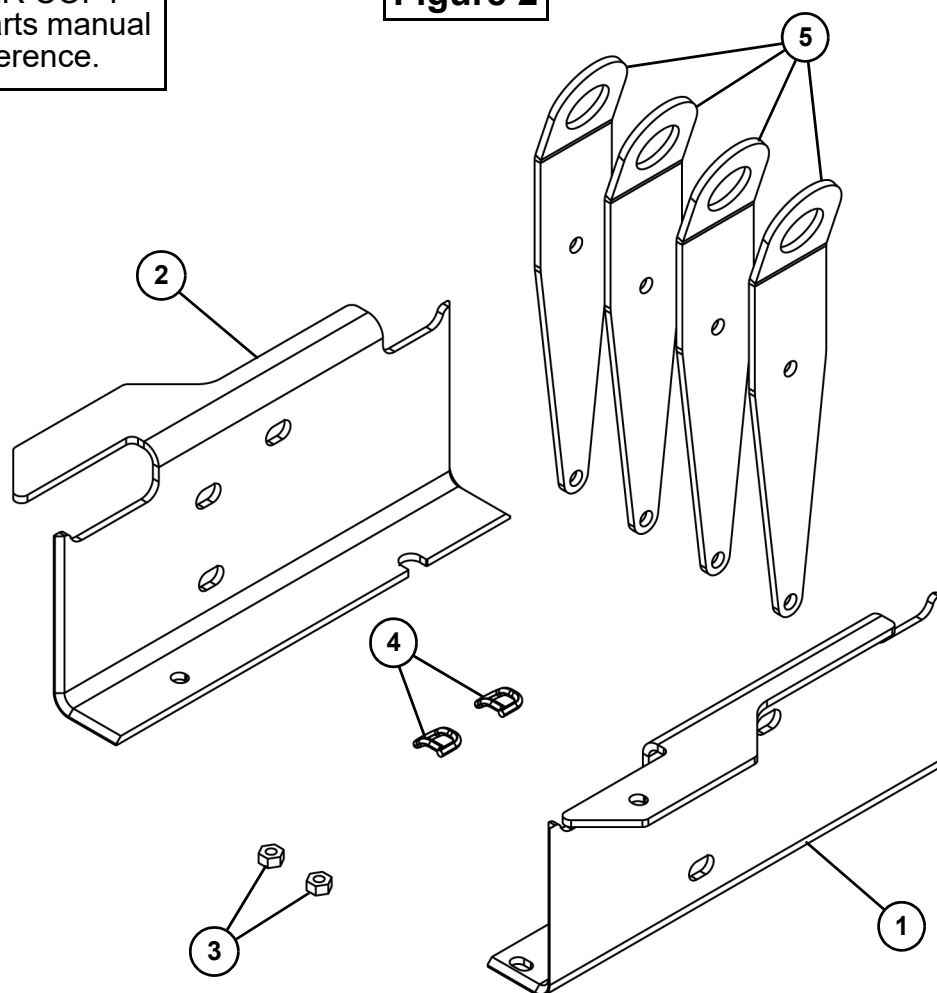

Figure 2 parts list

<u>REF. NO.</u>	<u>PART NO.</u>	<u>DESCRIPTION</u>	<u>IK02 QTY.</u>
1	163808186	PLATE – GUSSET	1
2	163808187	PLATE – GUSSET	1
3	508482010	NUT – HEXWELD, M10-1.50, DIN929	2
4	109430001	LINK – HARNESS TIEDOWN	2
5	180026225	FORMED PLATE – LIFT BRACKET	4
	IK02-4084	Kit includes all items in Figure 2 parts list.	

UNIT OWNER COPY
 Insert into parts manual
 for future reference.

Figure 3

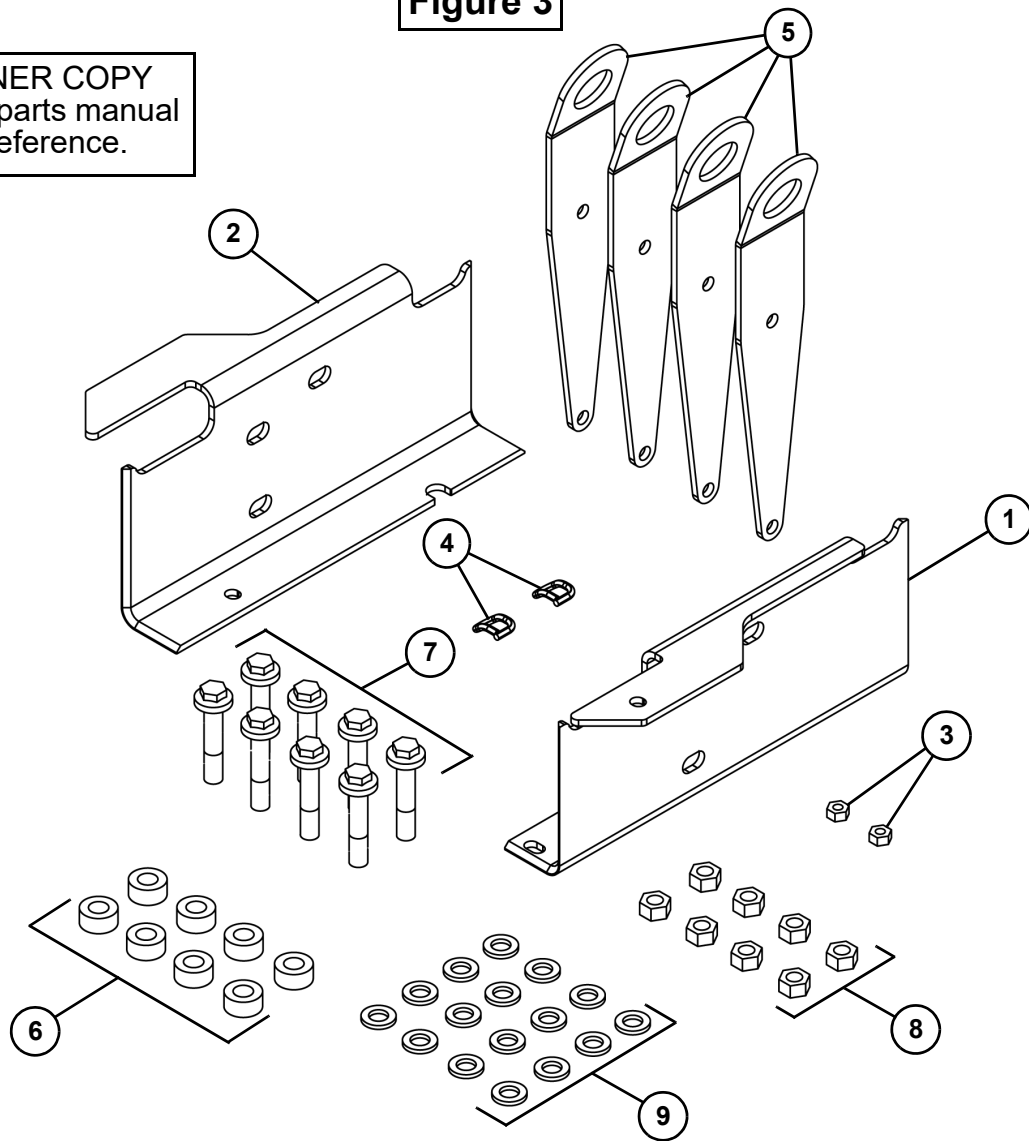

Figure 3 parts list

<u>REF. NO.</u>	<u>PART NO.</u>	<u>DESCRIPTION</u>	<u>IK03 QTY.</u>	<u>IK05 QTY.</u>	<u>IK06 QTY.</u>
1	163808186	PLATE – GUSSET	1	–	1
2	163808187	PLATE – GUSSET	1	–	1
3	508482010	NUT – HEXWELD, M10-1.50, DIN929	2	–	2
4	109430001	LINK – HARNESS TIEDOWN	2	–	2
5	180026225	FORMED PLATE – LIFT BRACKET	4	–	4
6	163777942	FRAME PUCKER SPACER – AX	8	8	–
7	507614080	SCREW – HFS-M16-2.00X80-10.9	8	8	–
8	507090016	NUT – HEX-M16-2.00-10	8	8	–
9	508486016	WASHER – FLATHARD-M16-17.0X30.0-4.0-D6916	16	16	–
	IK03-4084 IK05-4084 IK06-4084	Kits include listed items in Figure 3 parts list.			

UNIT OWNER COPY
Insert into parts manual
for future reference.

Figure 4

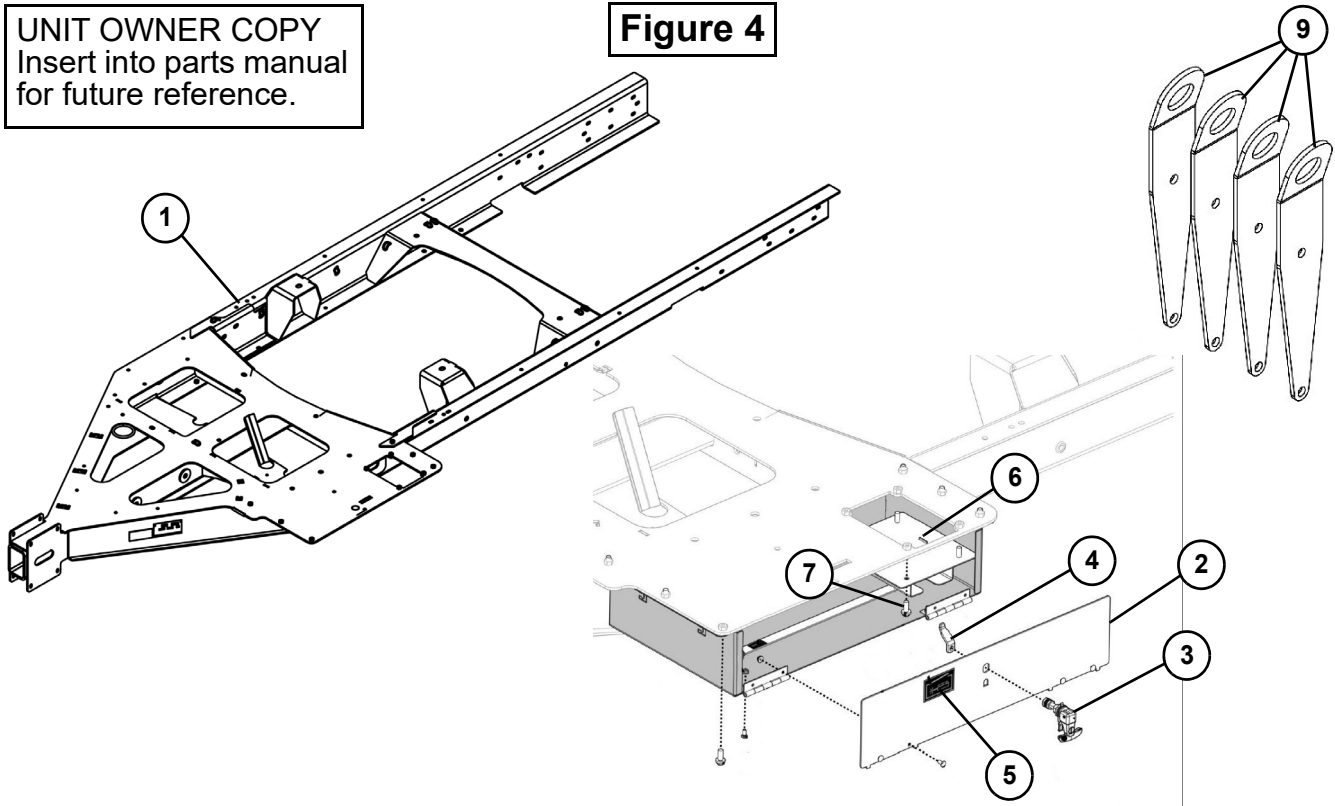

Figure 4 parts list

REF. NO.	PART NO.	DESCRIPTION	IK04 QTY.
1	163821149	ASSEMBLY - MAINFRAME	1
2	163800393	PLATE - TOOLBOX DOOR	1
3	296399680	LATCH - T HANDLE LOCKING	1
4	296399664	PLATE - CAM LATCH FOR DOOR LATCH	1
5	700IB851	DECAL - REMOTE STORAGE	1
6	163800499	WELDMENT - INNER COVER AND MOUNT	1
7	507612025	SCREW-HFS-M10-1.50X22-10.9-D6921-FT	4
8	1865007	GROMMET - 2561 BLACK (not shown)	4
9	180026225	FORMED PLATE - LIFT BRACKET	4
	IK04-4084	Kit includes all items in Figure 4 parts list.	