

**ATTENTION:**

- GENERAL MANAGER
- PARTS MANAGER
- CLAIMS PERSONNEL
- SERVICE MANAGER

IMPORTANT - All Service Personnel Should Read and Initial in the boxes provided, right.

© 2021 Subaru of America, Inc. All rights reserved.



QUALITY DRIVEN® SERVICE

**PRODUCT CAMPAIGN BULLETIN**

**APPLICABILITY:** 2017-2019 MY Impreza  
2018-2019 MY Crosstrek

**NUMBER:** WRE-21R

**DATE:** 04/23/21

**SUBJECT:** Ignition Coil Replacement

**NHTSA ID:** 21V-264

**REVISED:** 08/23/22

**INTRODUCTION:**

Subaru of America, Inc. (Subaru) is recalling certain 2017-2019 model year Impreza and 2018-2019 model year Crosstrek vehicles to check and, if necessary, update the ECM programming, and to replace all four ignition coils in each vehicle.

This recall supersedes Subaru’s previous WUQ-02 ignition coil reprogramming recall issued in October 2019. Effective April 23, 2021, any open WUQ-02 recall coverage has been expired, and WUQ-02 recall repairs should no longer be performed after that date.

All vehicles previously affected by the WUQ-02 recall are now affected by this new recall and must return to complete the WRE-21 recall repair.

**DESCRIPTION OF THE DEFECT AND SAFETY RISK:**

Subaru has determined that the ECM reprogramming was effective for vehicles that were repaired under previous recall WUQ-02. However, as a result of further analysis, Subaru has determined that all four ignition coils should be replaced to prevent the condition described below.

Under certain circumstances, the ignition coil may be energized longer than designed after the engine is OFF. If the ignition coil remains energized for too long, the internal temperature of ignition coil may increase which could cause a short circuit and a blown fuse. If a short circuit occurs while the vehicle is in motion, the vehicle may experience a loss of motive power while driving without the ability to immediately restart the engine.

If a short circuit in the ignition coil occurs while the vehicle is in motion, the vehicle may experience a loss of motive power while driving without the ability to immediately restart the engine, increasing the risk of a crash.

**CAUTION: VEHICLE SERVICING PERFORMED BY UNTRAINED PERSONS COULD RESULT IN SERIOUS INJURY TO THOSE PERSONS OR TO OTHERS.**

Subaru Service Bulletins are intended for use by professional technicians ONLY. They are written to inform those technicians of conditions that may occur in some vehicles, or to provide information that could assist in the proper servicing of the vehicle. Properly trained technicians have the equipment, tools, safety instructions, and know-how to do the job correctly and safely. If a condition is described, DO NOT assume that this Service Bulletin applies to your vehicle, or that your vehicle will have that condition.

**Subaru of America, Inc. is ISO 14001 Compliant**

ISO 14001 is the international standard for excellence in Environmental Management Systems. Please recycle or dispose of automotive products in a manner that is friendly to our environment and in accordance with all local, state and federal laws and regulations.

*Continued...*

## AFFECTED VEHICLES:

The number of U.S. vehicles affected by this recall is 466,205.

Model Year	Carline	Production Date Range
2017-2019	Impreza 4D	7/1/2016 - 6/17/2019
2017-2019	Impreza 5D	7/1/2016 - 6/17/2019
2018-2019	Crosstrek	5/09/17 – 5/08/2019

Not all vehicles in the production date ranges listed above are affected by this recall. Coverage must be confirmed by using the Vehicle Coverage Inquiry function on [subarunet.com](http://subarunet.com) prior to repair. This recall coverage information is now available.

Over the next several weeks, prior to owner notification, Subaru will be receiving air shipments of the parts needed to support the launch of this recall. Therefore, the status of the WRE-21 recall will display as “Open – Limited Parts Available” until the owner notification letters are released in June.

This status is for informational purposes and will not prevent the ability for retailers to perform and claim reimbursement for this repair prior to owner notification. Once the owner notification letters are released, the status will be updated to “Open.”

## DESCRIPTION OF THE REMEDY:

For all vehicles included in this recall, Subaru retailers will check and, if necessary, update the ECM programming, and replace all four ignition coils at no cost to the customer. If a certain DTC is found to be stored, Subaru will replace the front exhaust pipe at no cost as well.

## RETAILER RESPONSIBILITY:

Any vehicles listed in any recall/campaign that are in retailer stock must be:

- Immediately identified
- Tagged or otherwise marked to prevent their delivery or use prior to repair
- Repaired in accordance with the repair procedures outlined in the Product Campaign Bulletin

Retailers are to promptly perform the applicable service procedures to correct all affected vehicles in their inventory (used, demo & SSLP). Additionally, whenever a vehicle subject to this recall is taken into retailer inventory necessary steps should be taken to ensure the recall correction has been made before selling or releasing the vehicle.

Please be sure to download a copy of your complete inventory report from the [Vehicle Inventory Dashboard](#) available on [subarunet.com](http://subarunet.com) to identify any vehicles with open recalls that may be in your retail, CPO, and SSLP inventory. Affected vehicles will show an Open Recall column indicator (Y).

## OWNER NOTIFICATION:

Subaru will notify affected vehicle owners by first class mail in June. Retailers will be advised when the notification is scheduled.

*Continued...*

**PART INFORMATION:**

**IMPORTANT NOTES:**

- A quantity of FOUR (4) ignition coils must be ordered to repair ONE (1) vehicle.
- All orders for these ignition coils must be placed through PRIME only.

Description	Part Number	Qty. Required
COIL ASSEMBLY- IGNITION	22433AA7419S	4 Per Vehicle

**SERVICE PROCEDURE / INFORMATION:**

**REMINDER:** Customer satisfaction and retention starts with performing quality repairs.

The following Flow Chart is provided as an overview of the procedures required to perform this Recall. A detailed Service Procedure is also supplied below.

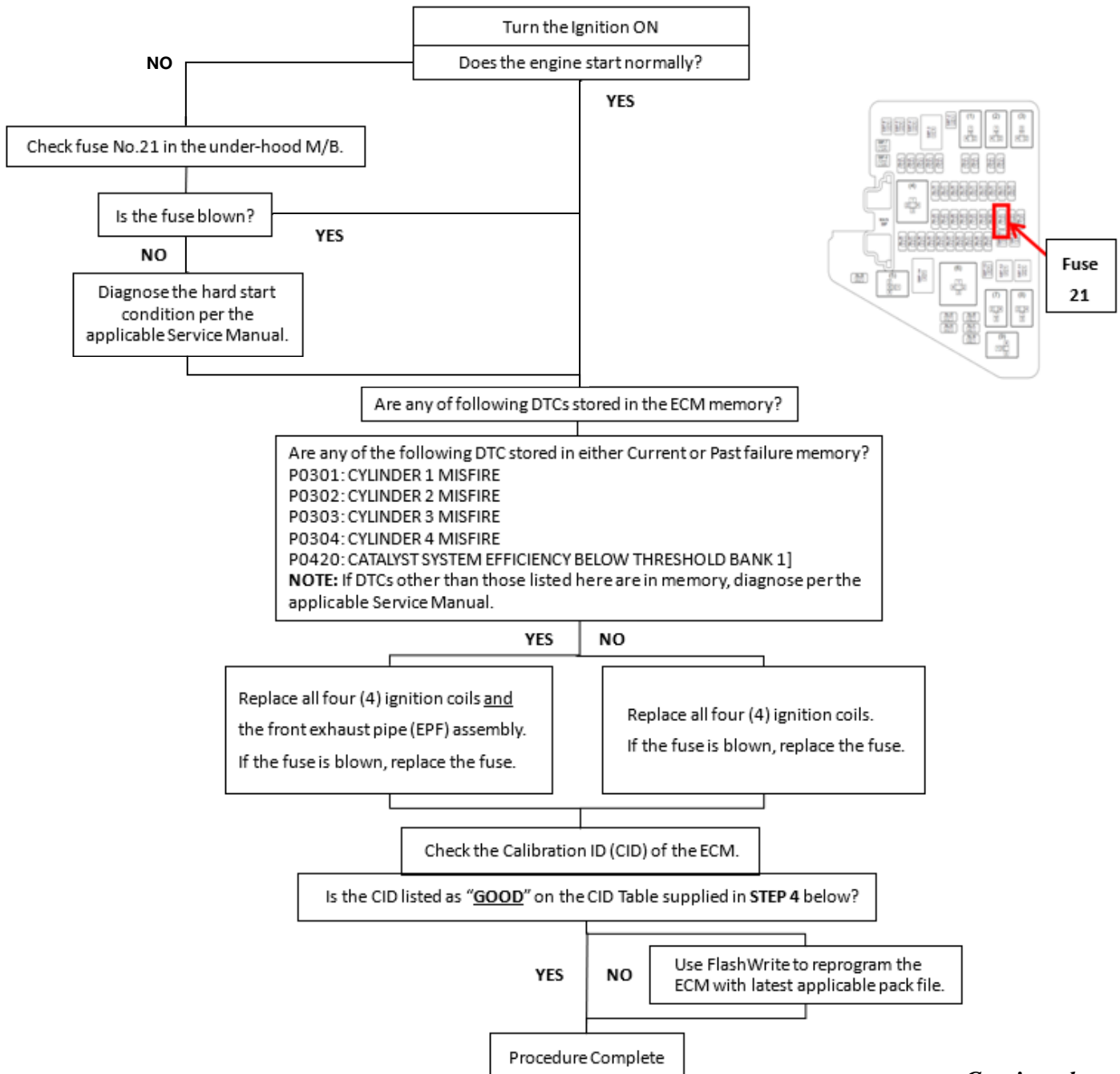

*Continued...*

**STEP 1)** Does the engine start normally?

**No** → The engine does **NOT** start normally: Proceed to **STEP 2** (inspection of fuses in M/B).

**Yes** → The engine starts normally: Proceed to **STEP 3**.

**STEP 2)** Inspect the M/B fuse #21 (15A) for **IMPREZA** and **CROSSTREK**. Is the fuse blown?

**No** → The fuse is **NOT** blown: Diagnose the hard starting condition per the applicable Service Manual then proceed to **STEP 3**.

**Yes** → The fuse **IS** blown: Proceed to **STEP 3**. After checking DTCs, replace the fuse.

**STEP 3)** Using the SSM scan for DTCs. Are any of the following DTCs current or stored in the ECM memory?

**[P0301: CYLINDER 1 MISFIRE]**

**[P0302: CYLINDER 2 MISFIRE]**

**[P0303: CYLINDER 3 MISFIRE]**

**[P0304: CYLINDER 4 MISFIRE]**

**[P0420: CATALYST SYSTEM EFFICIENCY BELOW THRESHOLD BANK 1]**

**No** → **NONE** of the DTCs are current or stored: Replace all four (4) ignition coils following the procedure in the applicable Service Manual.

**Yes** → **ANY** of DTCs are current or stored: Replace all four (4) of the ignition coils AND the Exhaust Pipe Front assembly following the procedure in the applicable Service Manual to perform the work

*Continued...*

**TIP:** When disconnecting the harness connectors from the ignition coils, squeeze the wire retaining clip (a) and push the connector off using a trim clip tool as shown in the illustration below. **DO NOT** remove the wire retaining clip from the harness connector.

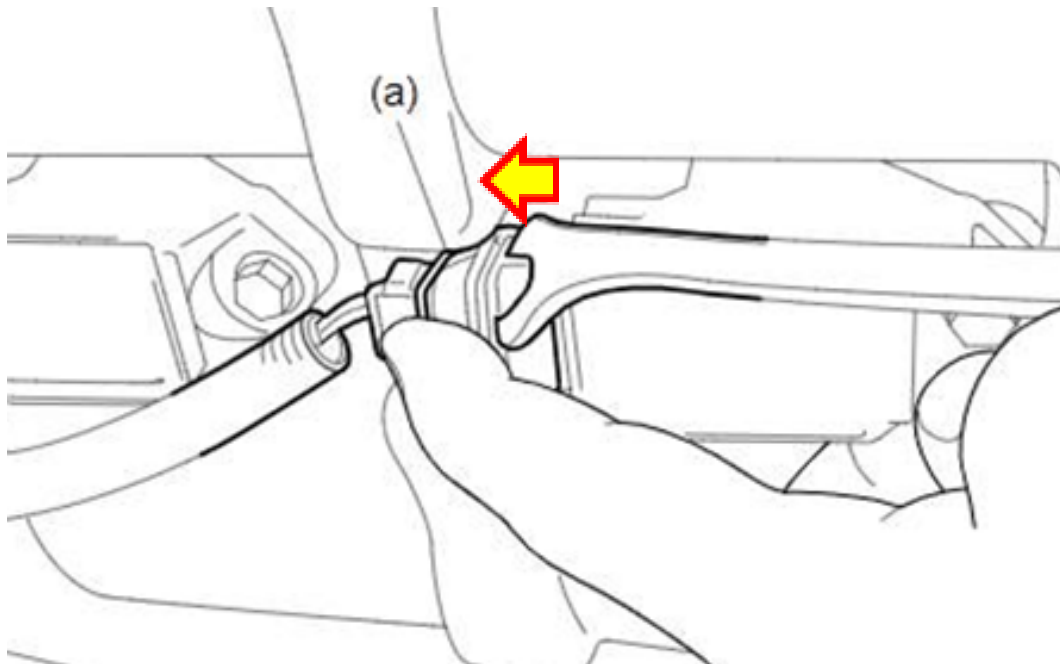

**IMPORTANT NOTE:**

It is **CRITICAL** to confirm a secure connection of terminal (C) to the main fuse box. The terminal **MUST** be torqued to **7.5N·m (0.8kgf-m, 5.5ft-lb)**.

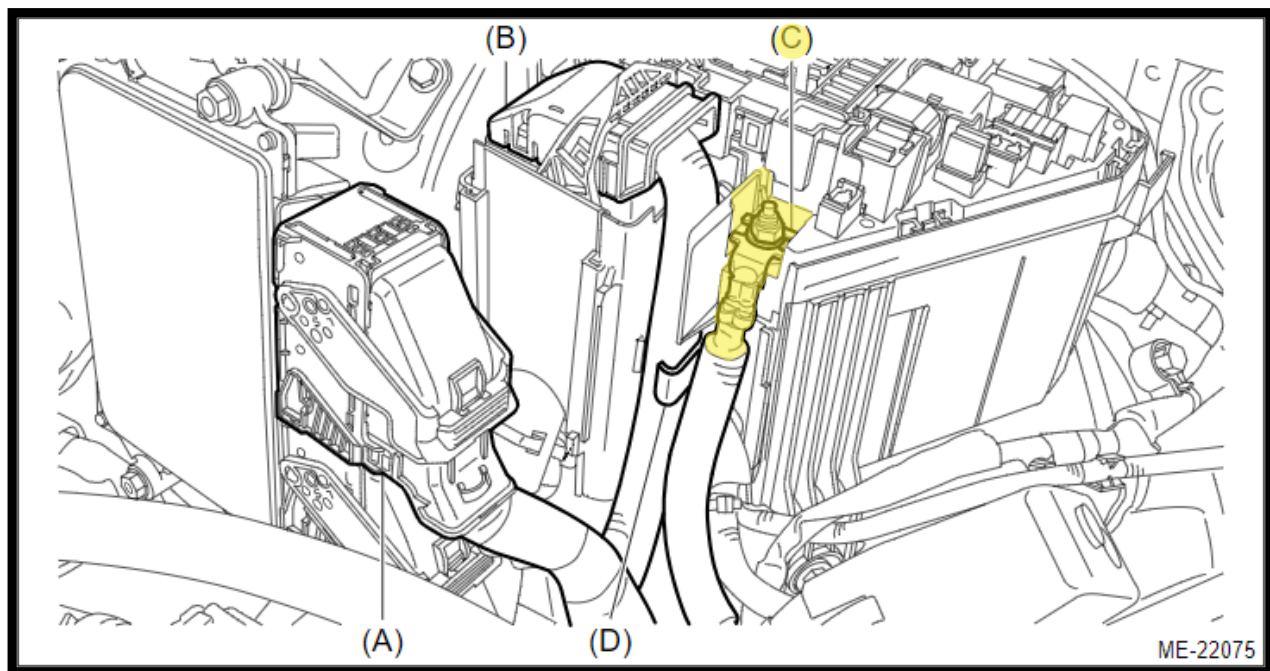

*Continued...*

**STEP 4)** Using the SSM, check the CID to determine if the ECM requires reprogramming. Compare the current CID to the “**GOOD**” CID numbers supplied in the table below.

**CRITICAL STEP:** Is the current CID listed as “**GOOD**” on the table below?

**No**  Current CID **IS NOT** listed as “**GOOD**” on the table below. **REPROGRAM THE ECM** to the latest available version using the normal FlashWrite procedure.

**Yes**  Current CID **IS** listed as “**GOOD**” on the table below. **DO NOT REPROGRAM THE ECM**. The procedure is complete. Proceed to **CLAIM REIMBURSEMENT AND ENTRY PROCEDURES** section.

Model	MY	Transmission Type	Active Grille Shutter Y/N	“GOOD” CID Numbers
Impreza	2017	CVT	Y	XH3J2B0D XH3J2E0D XH3J2C0D <b>XH3J2G0D</b>
				2017-18
	5MT	N	XH3J2B0A <b>XH3J2C1A</b> XH3J2C0A <b>XH3J2G0A</b>	
			CVT	
	2018	CVT		
			2019	5MT
	CVT	Y		
				5MT
	CVT	N		
			Crosstrek	2018
CVT	N	XH3J2B0F XH3J2C0F XH3J2E0F <b>XH3J2G0F</b>		
2019	6MT	Y		XH3N500E XH3N600E <b>XH3NA00E</b>
	CVT	N		XH3N500F XH3N600F XH3N800F <b>XH3NA00F</b>

**REMINDER:** If the current CID is listed in this table as “GOOD”, **DO NOT** reprogram the ECM.

*Continued...*

**PACK FILE APPLICABILITY:**

<b>Model Year, IMPREZA</b>	<b>PAK File Name</b>	<b>New ECM Part Number</b>	<b>Old ECM Part Numbers</b>	<b>Decryption Keyword</b>	<b>New ECM CID Number</b>
2017MY, CAL, MT W/ AGS	22765AU28A.pak	22765AU28A	22765AJ59A, B, C, D, E, F, G, H & J	BD9CAD75	XH3J2G0C
2017MY, CAL, CVT W/ AGS	22765AU29A.pak	22765AU29A	22765AJ60A, B, C, D, E, F, G, H & J	FE01CFEB	XH3J2G0D
2017MY, CAL, MT WO/ AGS	22765AU30A.pak	22765AU30A	22765AK61A, B, C, D, E, F, G, H & J	C3C6AC44	XH3J2G0A
2017MY, CAL, CVT WO/ AGS	22765AU31A.pak	22765AU31A	22765AL71A, B, C, D, E, F, G, H & J	182F9B0B	XH3J2G0B
2018MY, CAL, CVT WO/ AGS	22765AL71A.pak	22765AL71A	22765AM28A, B, C, D, E, F & G	250AEE3A	XH3J2C0B
2019MY, CAL, MT W/ AGS	22765AM64G.pak	22765AM64G	22765AM64A, B, D & E	6E8A55B5	XH3NA00C
2019MY, CAL, MT WO/ AGS	22765AM65G.pak	22765AM65G	22765AM65A, B, D & E	FAA8D023	XH3NA00A
2019MY, CAL, CVT W/ AGS	22765AM66G.pak	22765AM66G	22765AM66A, B, D & E	FC067661	XH3NA00D
2019MY, CAL, CVT WO/ AGS	22765AM67G.pak	22765AM67G	22765AM67A, B, C, D & E	5CC20BED	XH3NA00B

<b>Model Year, CROSSTREK</b>	<b>PAK File Name</b>	<b>New ECM Part Number</b>	<b>Old ECM Part Numbers</b>	<b>Decryption Keyword</b>	<b>New ECM CID Number</b>
2018MY, CAL, 6MT	22765AJ618.pak	22765AJ618	22765AJ610, 11, 12, 13, 14, 15, 16	F9F53E35	XH3J2G0E
2018MY, CAL, CVT	22765AJ628.pak	22765AJ628	22765AJ620, 21, 22, 23, 24, 25 & 26	B9308D26	XH3J2G0F
2019MY, CAL, 6MT WO/ AGS	22765AM816.pak	22765AM816	22765AM810, 11, 12, 13 & 14	D2566269	XH3NA00E
2019MY, CAL, CVT WO/ AGS	22765AM826.pak	22765AM826	22765AM820, 21, 22, 23 & 24	150AAA5D	XH3NA00F

*Continued...*



# CALIFORNIA “VEHICLE EMISSION RECALL - PROOF OF CORRECTION” CERTIFICATE

The California Air Resources Board and the Department of Motor Vehicles Registration/Recall Program requires that all emission related Recall/Campaign or Service Program repairs be completed before a vehicle registration is renewed. Please provide owners of vehicles registered in the state of California a completed “Vehicle Emission Recall - Proof of Correction” certificate. Vehicle owners should be advised to retain this certificate because the California Department of Motor Vehicles may require they provide proof this service program repair has been completed. Additional certificates are available through normal parts ordering channels using part number MSA6P1301. Quantity 1 = 1 booklet of 50 certificates.

## SERVICE PROGRAM IDENTIFICATION LABEL:

Type or print the necessary information on a Campaign Identification Label. The completed label should be attached to the vehicle’s upper radiator support. Additional labels are available through normal parts ordering channels. The part number is **MSA6P1302**, which comes as one sheet of 20 labels.

Part Number	Applicability	Description	Order Quantity
MSA6P1302	All Models	Campaign Completion Labels (contains one sheet of 20 labels)	1

*Continued...*



## CLAIM REIMBURSEMENT AND ENTRY PROCEDURES:

Credit to perform this recall will be based on properly completed repair order information. Retailers may submit claims through Subarunet.com.

Labor Description	Labor Operation #	Labor Time	Fail Code	Claim Type
ECM CID / DTC CHECK, REPLACE ALL IGNITION COILS	A181-341	1.1	WRE-21	RC
ECM CID / DTC CHECK, REPLACE ALL IGNITION COILS, REPROGRAM ECM	A181-342	1.5		
ECM CID / DTC CHECK, REPLACE ALL IGNITION COILS, REPLACE EPF ASSEMBLY	A181-343	1.9		
ECM CID / DTC CHECK, REPLACE ALL IGNITION COILS, REPLACE EPF ASSEMBLY, REPROGRAM ECM	A181-344	2.3		

## IMPORTANT REMINDERS:

- SOA strongly discourages the printing and/or local storage of service information as previously released information and electronic publications may be updated at any time.
- Always check for any open recalls or campaigns anytime a vehicle is in for servicing.
- Always refer to STIS for the latest service information before performing any repairs.

*Continued...*

**URGENT  
IMPORTANT SAFETY RECALL**

**This notice applies to the VIN identified  
in the address section printed below**



**SUBARU**

Subaru of America, Inc  
PO Box 9103  
Camden, NJ 08101-9877  
844-373-6614  
www.subaru.com

**Subaru Safety Recall WRE-21  
NHTSA ID 21V-264  
June 2021**

**Dear Subaru Owner:**

This notice is sent to you in accordance with the National Traffic and Motor Vehicle Safety Act.

SUBARU OF AMERICA, INC. has decided that a defect, which relates to motor vehicle safety, exists in certain 2017-2019 Impreza vehicles and 2018-2019 model year Crosstrek vehicles.

You received this notice because our records indicate that you currently own one of these vehicles.

This recall replaces Subaru's previous WUQ-02 ignition coil reprogramming recall issued in October 2019. All vehicles affected by the previous recall must return to complete the WRE-21 recall repair, even if the previous recall repair was completed.

**REASON FOR THIS SAFETY RECALL**

Subaru has determined that the ECM reprogramming was effective for vehicles that were repaired under previous recall WUQ-02. However, as a result of further analysis, Subaru has determined that all ignition coils should be replaced to prevent the condition described below.

Under certain circumstances, the ignition coil may remain energized longer than designed after the engine is OFF. If the ignition coil remains energized for too long, the internal temperature of the ignition coil may increase which could cause a short circuit and a blown fuse.

**SAFETY RISK**

If a short circuit in the ignition coil occurs while the vehicle is in motion, the vehicle may experience a sudden loss of power while driving without the ability to immediately restart the engine, increasing the risk of a crash.

**WHAT SUBARU WILL DO**

Subaru will check and, if necessary, update the electronic control module (ECM) programming, and replace all four ignition coils in your vehicle at no cost to you. Additionally, in the unlikely event that a certain diagnostic trouble code (DTC) is found, Subaru will replace the front exhaust pipe including the catalytic converter at no cost to you.

**WHAT YOU SHOULD DO**

As mentioned above, ***all*** vehicles affected by the previous recall must return to complete the WRE-21 recall repair, even if the previous recall repair was completed.

Please contact your Subaru retailer (dealer) immediately for an appointment to have this repair performed, at no cost to you.

## HOW LONG WILL THE REPAIR TAKE?

The time required for the ECM program check, DTC check, and ignition coil replacement is approximately one hour and ten minutes. However, if it is determined that the ECM needs to be reprogrammed, that reprogramming will require an additional twenty minutes.

In the unlikely event that a certain DTC is found, the front exhaust pipe including the catalytic converter will need to be replaced. That replacement, if necessary, will require an additional fifty minutes.

Your retailer can provide you with a better estimate of the overall time for this service visit, as it may be necessary to leave your vehicle for a longer period of time on the day of your scheduled appointment to allow your Subaru retailer flexibility in scheduling.

For your convenience, your retailer may provide you with a loaner or rental vehicle, at no cost to you, until the repair is complete.

## OWNER INFORMATION

Government regulations require that recall notifications be sent to the last known owner of record. That information is based primarily on state registration and title data. If you are a lessor of this vehicle, federal regulations require you to forward this notice to your lessee within ten days.

If you have moved or sold your vehicle, please update this information online at [www.subaru.com](http://www.subaru.com), select 'Customer Support,' then select 'Address Update' or 'Ownership Update' from the "Quick Links" menu.

## CALIFORNIA REGISTERED OWNERS

The California Air Resources Board requires that emission related campaigns be completed prior to California's vehicle registration renewal process; without this repair, you will not be able to register your vehicle during your next annual registration. Upon completion of this campaign, your California dealer will complete and provide you a "Proof of Correction Certificate." If required, present the certificate to the California Department of Motor Vehicles (the "DMV") when renewing your California registration as proof of campaign completion. If the DMV does not request the certificate, we recommend that you keep it for your records.

In addition, the State of California requires that every vehicle must pass an emission test (SMOG Check) every two years and before it is sold. ***Without the repair we are providing at no charge, your vehicle may not pass this test.***

## IF YOU HAVE PREVIOUSLY PAID FOR A REPAIR

If you have already paid for repairs associated with this coverage, you may be eligible for reimbursement. Reimbursement consideration will be based on the amount an authorized Subaru retailer in your area would charge for the same repair.

Please send the original service repair order, which has the name of the repair facility, date of repair, mileage at the time of repair, complete 17-digit vehicle identification number (VIN), and your name, with correct mailing address and telephone number to the address listed below.

**Subaru of America, Inc.**

**Customer Advocacy Department, Attention: WRE-21 Recall**

**P.O. Box 9103, Camden, NJ 08101-9877**

*Continued...*

Please send original receipts only and retain a photocopy for your records. Please be assured that we will attempt to process your reimbursement request as quickly as possible, but it may take up to 60 days for this process to be completed.

**IF YOU NEED FURTHER ASSISTANCE:**

To locate the nearest Subaru retailer, you can access our website at [www.subaru.com](http://www.subaru.com) and select 'Find a Retailer.'

For additional information, please go to: <http://www.wre21.service-campaign.com>.

If you need additional assistance, please contact us directly:

- By e-mail: Go to [www.subaru.com](http://www.subaru.com) and select "Contact Us"
- By telephone: 1-844-373-6614  
Monday through Friday between 8:00 a.m. and 7:00 p.m. ET
- By U.S. Postal mail: Write us at Subaru of America, Inc.  
Attn: Customer Advocacy Department  
P.O. Box 9103, Camden, NJ 08101-9877

To subscribe to the NHTSA Recall Notification email System, please go to: <https://www-odi.nhtsa.dot.gov/nhtsa/subscriptions>.

Please contact us immediately if the Subaru retailer fails or is unable to make the necessary repairs free of charge.

You may also contact the Administrator, National Highway Traffic Safety Administration (NHTSA), 1200 New Jersey Ave., SE, Washington, DC 20590 or call the toll-free Vehicle Safety Hotline at 1-888-327-4236 (TTY: 1-800-424-9153) or go to <http://www.NHTSA.gov> if you believe the Subaru retailer has failed or is unable to remedy your vehicle without charge within a reasonable amount of time.

Your continued satisfaction with your Subaru is important to us. Please understand that we have taken this action in the interest of your safety and your vehicle's proper operation. We sincerely apologize for any inconvenience this matter may cause and urge you to schedule an appointment as soon as possible.

Sincerely,

Subaru of America, Inc.

A subsidiary of SUBARU CORPORATION