



# VOLUNTARY RECALL CAMPAIGN

Classification: WT21-004A	Reference: NTB21-021A	Date: June 2, 2022
------------------------------	--------------------------	-----------------------

## VOLUNTARY SAFETY RECALL CAMPAIGN 2018-2021 TITAN; GENERAL GRABBER APT & GENERAL GRABBER HTS TIRE INSPECTION

This bulletin has been amended. See AMENDMENT HISTORY on the last page.  
Please discard previous versions of this bulletin.

**CAMPAIGN ID #:** PC798  
**APPLIED VEHICLES:** 2018-2021 Titan (A61) – non-XD models

**Check Service COMM or Dealer Business Systems (DBS)  
National Service History to confirm campaign eligibility.**

**NOTE:** This campaign does not apply to Titan XD models.

### INTRODUCTION

Nissan is conducting this voluntary safety recall campaign on certain specific model year 2018-2021 Titan non-XD models with General Grabber APT tires, size 275/70 R18, or with General Grabber HTS tires, size 265/70 R18, to inspect all four (4) tires and, if necessary, replace the tires that match the inspection result criteria. This service will be performed at no charge to the customer for parts or labor.

### IDENTIFICATION NUMBER

Nissan has assigned identification number PC798 to this campaign. This number must appear on all communication and documentation of any nature dealing with this campaign.

### DEALER RESPONSIBILITY

It is the dealer's responsibility to check Service COMM or Dealer Business Systems (DBS) National Service History for the campaign status on each vehicle falling within the range of this voluntary safety recall which for any reason enters the service department. This includes vehicles purchased from private parties or presented by transient (tourist) owners and vehicles in a dealer's inventory. **Federal law requires that new vehicles in dealer inventory which are the subject of a safety recall must be corrected prior to sale. Failure to do so can result in civil penalties by the National Highway Traffic Safety Administration.** While federal law applies only to new vehicles, Nissan strongly encourages dealers to correct any used vehicles in their inventory before they are retailed.

Nissan Bulletins are intended for use by qualified technicians, not 'do-it-yourselfers'. Qualified technicians are properly trained individuals who have the equipment, tools, safety instruction, and know-how to do a job properly and safely. **NOTE:** If you believe that a described condition may apply to a particular vehicle, DO NOT assume that it does. See your Nissan dealer to determine if this applies to your vehicle.

## SERVICE PROCEDURE

1. Locate and identify the DOT Week Code of each tire (Figure 1 and Figure 2).

**NOTE:** Figure 2 shows an example of the DOT Week Code for a General Grabber APT P275/70 R18 (Tire Type Code HMAD).

- If the DOT Week Code is **0120**, **5218**, or **1818**, continue to step 2 on page 3.
- If the DOT Week Code is not **0120**, **5218** or **1818**, the inspection result is OK and the vehicle may be released. See **CLAIMS INFORMATION** on page 5.

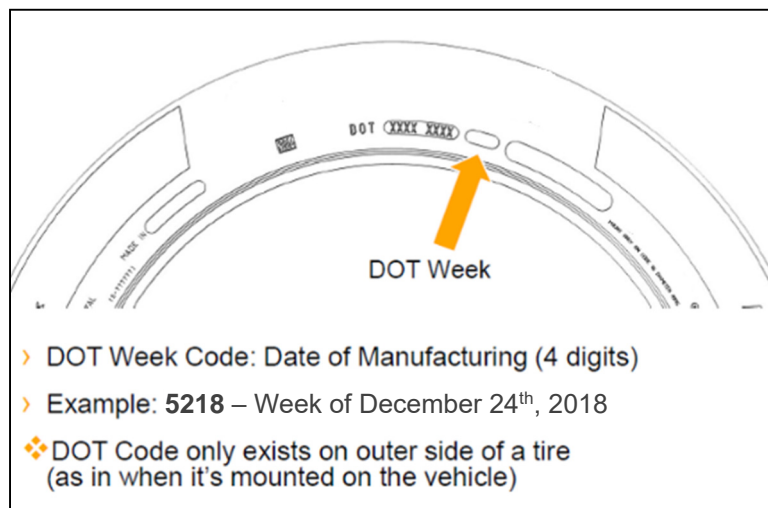

Figure 1

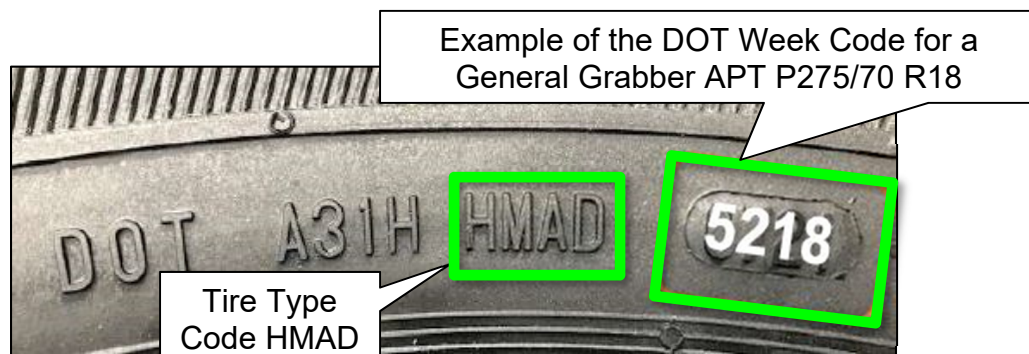

Figure 2

2. Locate and identify the Tire Mold ID of each tire (Figure 3 and Figure 4).

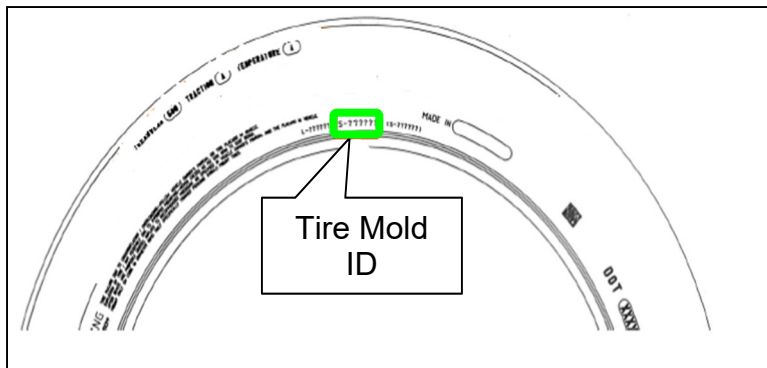

Figure 3

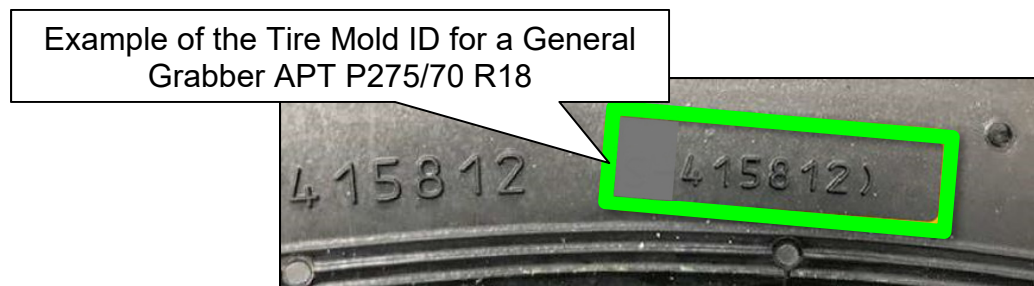

Figure 4

3. Compare the DOT Week Code and the Tire Mold ID to those in **Table A**, below.
- If the DOT Week Code and the Tire Mold ID match what is shown in **Table A**, continue to step 4 for replacement of only the incident tire(s).
  - If the DOT Week Code and the Tire Mold ID do not match what is shown in **Table A**, the inspection result is OK and the vehicle may be released. See **CLAIMS INFORMATION** on page 5.

**Table A**

DOT WEEK CODE	TIRE MOLD ID	TIRE SIZE AND DESCRIPTION
0120	415813	275/70R18 116S TL Grabber APT
5218	415812	275/70R18 116S TL Grabber APT
1818	415465	265/70R18 116S TL Grabber HTS

4. For vehicles equipped with General Grabber **APT P275/70 R18** tires:

- Replace each tire that has:
  - DOT Week Code **0120** and Tire Mold ID **415813**
  - DOT Week Code **5218** and Tire Mold ID **415812**

For vehicles equipped with General Grabber **HTS P265/70 R18** tires:

- Replace each tire that has DOT Week Code **1818** and Tire Mold ID **415465**.

**NOTE:**

- Refer to the ESM, section **SUSPENSION > ROAD WHEELS & TIRES > REMOVAL AND INSTALLATION > WHEEL AND TIRE.**
- Wheel nut torque: 133 N·m (14 kg-m, **98 ft-lb**)

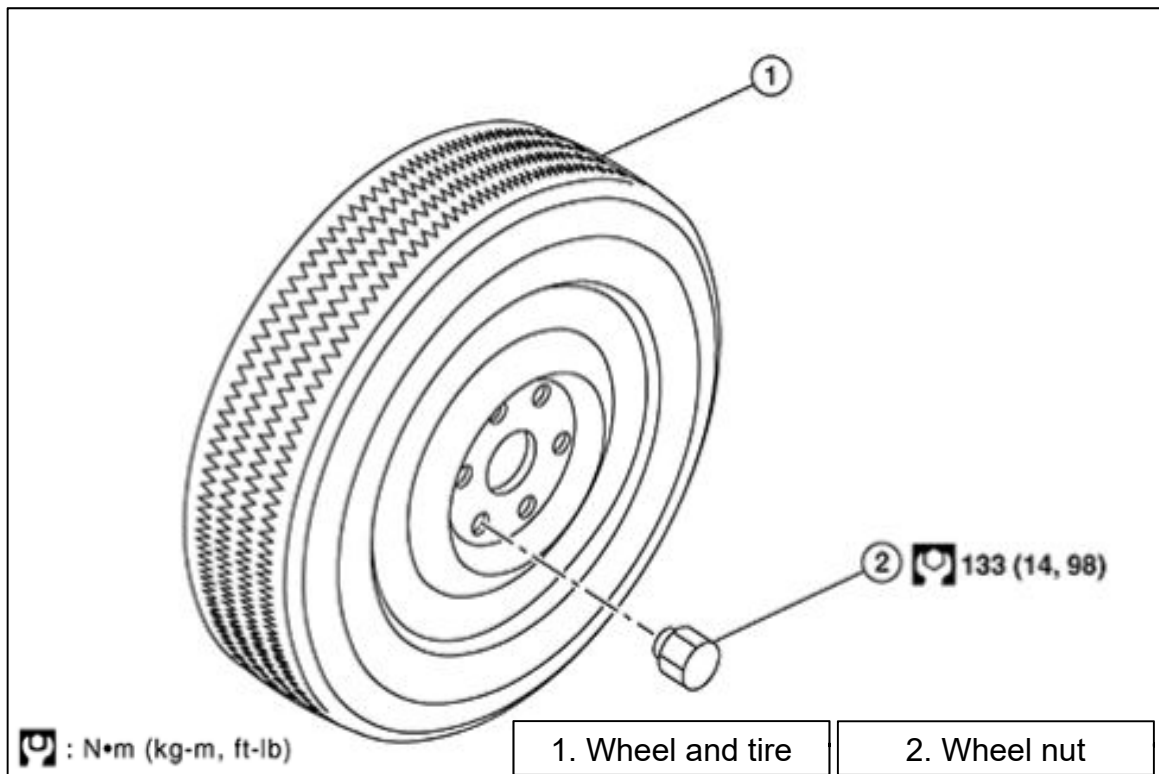

Figure 5

5. Use a 1/2" drill bit to drill two holes through the sidewall of the removed tire(s), and dispose of the tire(s) properly following all local, state, and federal regulations.

## PARTS INFORMATION

DESCRIPTION	PART NUMBER	QUANTITY
Replacement Tire General Grabber APT P275/70 R18 (1)	OETIR-02973	As needed
Replacement Tire General Grabber HTS P265/70 R18 (1)	OETIR-02974	As needed

- (1) Order this item through the Nissan Maintenance Advantage program: Phone 877-NIS-NMA1 (877-647-6621). Website order via link on the dealer portal; [www.NNAnet.com](http://www.NNAnet.com) and click on the "Maintenance Advantage-Tire/Battery/Chemical" link.

## CLAIMS INFORMATION

Submit a "CM" line claim using the following claims coding:

CAMPAIGN ("CM") ID	DESCRIPTION	OP CODE	FRT
PC798	Inspect Four (4) Tires	PC7980	0.2
	Inspect Four (4) Tires and Replace One (1) Tire	PC7981	0.7
	Inspect Four (4) Tires and Replace Two (2) Tires	PC7982	1.0
	Inspect Four (4) Tires and Replace Three (3) Tires	PC7983	1.3
	Inspect Four (4) Tires and Replace Four (4) Tires	PC7984	1.6

## EXPENSE CODE

EXPENSE CODE	DESCRIPTION	MAX AMOUNT
599 *	Replacement General APT Tire P275/70R18	\$1,400.00
554 *	Replacement General HTS Tire P265/70R18	\$1,240.00

\*Use this **EXPENSE CODE** for tire(s) reimbursement. DO NOT claim the Dealer Tire part number on the claim. This expense code should only be used when a tire(s) is replaced.

**NOTE:** MAX AMOUNT includes local and state tax as well as disposal fees.

## AMENDMENT HISTORY

<b>PUBLISHED DATE</b>	<b>REFERENCE</b>	<b>DESCRIPTION</b>
March 11, 2021	NTB21-021	Original bulletin published
June 2, 2022	NTB21-021A	Changes made throughout

