

AMA3 - Reworking Various Threaded Connections on the Chassis (Recall Campaign)

Model Line: **Taycan (Y1A, Y1B)**

Model Year: **2021**

Concerns: **Hexagon clamping nut M12 x 1.5 on various threaded connections on the chassis**

Information: **There is a possibility that clamping nuts, on which the thread was not manufactured according to specifications, were installed on various threaded connections on the chassis on the affected vehicles.**

As a result, the required tightening torque was reached before the threaded connection was actually tightened fully when installing the clamping nuts. There is therefore no guarantee that the affected threaded connections will remain sufficiently tight over the service life of the vehicle.

General Information on Warranty Processing: The scopes listed below for this measure **do not include published labor time and they only provide the minimum number of parts for reworking the respective vehicles. For this unique business case** all labor and any additional parts that may be required depending on the result of a campaign scope check must be submitted as a subsequent credit appeal to the initial paid campaign line. Any additional parts and labor added to the initial AMA3 campaign line that is not a part of the published scope will result in a system error preventing the claim from processing. Due to this unique business case, the campaign scope must be submitted and paid first, then a credit for additional parts and labor thereafter.

Action required: Rework threaded connections on the front and rear axle.
On vehicles that have already been delivered to customers, the screwed components must also be checked for damage.



Information

Please note that different screw positions on the front and rear axle must be reworked on the affected vehicles.

The following specific campaign scopes have therefore been defined for reworking the threaded connections. Every vehicle is clearly assigned just one campaign scope.

The relevant **M12 x 1.5 fastening nuts must be replaced on all affected vehicles**, depending on the assigned scope.

In addition, the **relevant fastening screws** must also be replaced.

On vehicles on which **a component is screwed at the relevant screw point** (e.g. actuator or connecting link), depending on the assigned scope, the **thread on the relevant component must be checked** and the component may also have to be replaced, depending on the result of the check.

On vehicles that have **already been delivered to customers**, the **components that are screwed together** must **also** be **checked for damage** caused by **relative movements** while driving as fittings, contact surfaces or bores on the individual components may have been damaged. The relevant components may also have to be replaced, depending on the result of the check.

Example of a **damaged thread on the actuator**:
⇒ *Damaged thread on actuator*



Damaged thread on actuator

Example of **damage caused by driving**: ⇒ *Damage to component caused by driving*

For an overview of each of the assigned scopes, see list below.

The scope that is clearly assigned to an affected vehicle is shown in the PCSS vehicle information for this campaign.

Scope 1 – Scope 9: Not relevant for this vehicle type.

Scope 10: ⇒ *Technical Information 'Scope 10: Reworking threaded joints on the front axle'*

- Reworking threaded joint securing **spring struts on lower control arms at the left and right on the front axle**
- Reworking threaded joint securing **connecting link (suspension/stabilizer) to left and right anti-roll bar on the front axle**

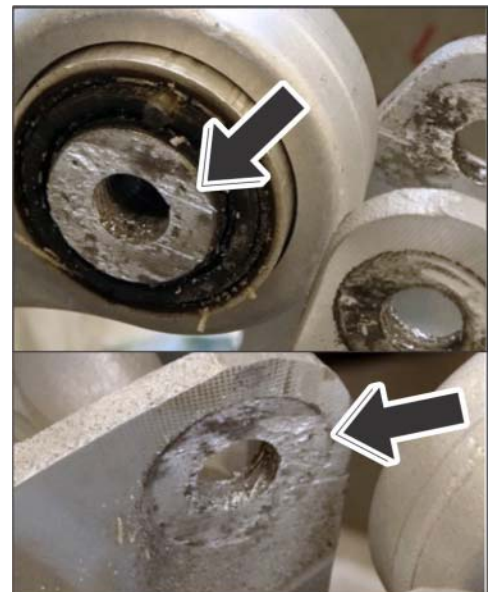

Damage to component caused by driving

Scope 11: ⇒ *Technical Information 'Scope 11: Reworking threaded joints on the rear axle'*

- Reworking **front** threaded joint securing **lower trailing arms at left and right on the rear axle housing**
- Reworking bolts securing **lower trailing arm to left and right wheel bearing housing on the rear axle**

Scope 12: ⇒ *Technical Information 'Scope 12: Reworking threaded joints on the rear axle'*

- Reworking bolts securing **(front) upper longitudinal arm to left and right rear axle carrier**
- Reworking threaded joint securing **upper (front) longitudinal arm to left and right wheel bearing housing on the rear axle**
- Reworking bolts securing **(rear) upper trailing arm to left and right rear axle carrier**
- Reworking threaded joint securing **upper (rear) trailing arms to left and right wheel bearing housing on the rear axle**

Scope 13: ⇒ *Technical Information 'Scope 13: Reworking threaded joints on front and rear axle'*

- Reworking threaded joint securing **spring struts on lower control arms at the left and right on the front axle**
- Reworking threaded joint securing **connecting link (suspension/stabilizer) to left and right anti-roll bar on the front axle**
- Reworking bolts securing **(front) upper longitudinal arm to left and right rear axle carrier**
- Reworking threaded joint securing **upper (front) longitudinal arm to left and right wheel bearing housing on the rear axle**
- Reworking bolts securing **(rear) upper trailing arm to left and right rear axle carrier**
- Reworking threaded joint securing **upper (rear) trailing arms to left and right wheel bearing housing on the rear axle**

Scope 14: ⇒ *Technical Information 'Scope 14: Reworking threaded joints on front and rear axle at the right'*

- Reworking threaded joint securing **connecting link (suspension/stabilizer) to right anti-roll bar on the front axle**
- Reworking threaded joint securing **lower trailing arm to right wheel bearing housing on the rear axle**

Scope 15: ⇒ *Technical Information 'Scope 15: Reworking threaded joint on the left of the rear axle'*

- Reworking threaded joint securing **shock absorber on lower transverse control arm at left on the rear axle**

Scope 16: ⇒ *Technical Information 'Scope 16: Reworking threaded joints on the front axle'*

- Reworking threaded joint securing **spring struts on lower control arms at the left and right on the front axle**
- Reworking threaded joint securing **steering gear to front-axle carrier at the left**

Scope 17: ⇒ *Technical Information 'Scope 17: Reworking threaded joint on the front axle'*

- Reworking threaded joint securing **electric drive motor to front-axle module at the front left**

Scope 18: ⇒ *Technical Information 'Scope 18: Reworking threaded joints on front and rear axle'*

- Reworking threaded joint securing **spring struts on lower control arms at the left and right on the front axle**
- Reworking **front** threaded joint securing **lower trailing arms at left and right on the rear axle housing**

Affected Vehicles: Only vehicles assigned to the campaign (see also PCSS Vehicle Information). This campaign affects 395 vehicles.

Parts required

Parts Info: Clamping nuts required for all affected vehicles:

Part No.	Designation	Qty.
PAF909664	Lock nut, M12 x 1.5	Scope-specific



Information

Due to the different screw positions to be reworked on the front and rear axle of each vehicle, the required fastening nuts and screws are listed in the relevant scope.

All additional parts that are required must be determined independently in accordance with the Porsche Electronic Parts Catalogue (PET).

Required tools

Tools: **General tools:**

- Torque wrench, 2–10 Nm (1.5–7.5 ftlb.), e.g. **VAG 1783 Torque wrench, 2-10 Nm (1.5-7.5 ftlb.)**
- Torque wrench, 6–50 Nm (4.5–37 ftlb.), e.g. **VAG 1331A Torque wrench, 6-50 Nm (4.5-37 ftlb.)**
- Torque wrench, 40–200 Nm (30–148 ftlb.), e.g. **VAG 1332 Torque wrench, 40-200 Nm (30-148 ftlb.)**
- Electronic torque angle torque wrench, 2-100 Nm (1.5-74 ftlb.), e.g. **9768 - Electronic torque wrench, 2 - 100 Nm (1.5 - 74 ftlb.)**
- Electronic torque angle torque wrench, 20-400 Nm (15-296 ftlb.), e.g. **VAS 6942 Torque angle torque wrench, 20-400 Nm (15-296 ftlb.)**

All other required (special) tools in accordance with the linked Workshop Manuals depending on the relevant assigned scope.

Scope 10: Reworking threaded joints on the front axle

Parts Info: **Parts required for this scope:**

Part No.	Designation – Use	Qty.
PAF909664	⇒ Lock nut, M12 x 1.5 – Spring strut to wishbone – Connecting link to anti-roll bar	4 ea.
PAF108544	⇒ Lens-head screw, M12 x 1.5 x 90 – Spring strut to wishbone	2 ea.
N 10793603	⇒ Hexagon-head bolt, M12 x 1.5 x 60 – Connecting link to anti-roll bar	2 ea.



Information

For all other parts that may be required, see Porsche Electronic Parts Catalogue (PET).

- Work Procedure: 1 Raise the vehicle using a lifting platform ⇒ *Workshop Manual '4X00IN Lifting the vehicle'*.
- 2 Remove front wheel at the left and right ⇒ *Workshop Manual '440519 Removing and installing wheel'*.
- 3 Replace the following threaded connections on the **front axle at the left and right**:
- **Threaded joint securing spring strut to lower trailing arm on the front axle**
 - **Threaded joint securing connecting link to anti-roll bar on the front axle**

Also only for vehicles that have already been delivered to customers: After removing the relevant bolts, perform a **visual inspection** for **signs of damage caused by driving** in the area around the relevant screw points.

The **relevant components may also have to be replaced**, depending on the result of the check.

- 3.1 Release air from and fill air into front air springs at the left and right using the PIWIS Tester ⇒ *Workshop Manual '430117 Bleeding and filling the levelling system'*.
- 3.2 Support the wheel bearing housing using a suitable engine and gearbox jack. On vehicles with PCCB brake discs, make sure not to damage the brake disc.

- 3.3 Loosen and unscrew fastening nut \Rightarrow *Air-spring strut fork -3-* on spring strut fork \Rightarrow *Air-spring strut fork -1-*.
Counter fastening screw \Rightarrow *Air-spring strut fork -4-* while doing this. Then remove the fastening screw.

- 3.4 Insert a new fastening screw into spring strut fork \Rightarrow *Air-spring strut fork -1-* and lower trailing arm \Rightarrow *Air-spring strut fork -2-*.

- 3.5 Screw on new fastening nut and tighten.
Counter the fastening screw while doing this.
Tightening torque 90 Nm (67 ftlb.)
Torque angle +120°

- 3.6 Lower the engine and gearbox jack and remove it.

- 3.7 Loosen and unscrew fastening nut \Rightarrow *Connecting link for anti-roll bar -2-* from connecting link \Rightarrow *Connecting link for anti-roll bar -1-* to anti-roll bar.
Counter fastening screw \Rightarrow *Connecting link for anti-roll bar -3-* while doing this. Then remove the fastening screw.

Please note: Fastening nut \Rightarrow *Connecting link for anti-roll bar -4-* is **not affected** and must not be loosened.

- 3.8 Insert new fastening screw into the anti-roll bar and connecting link.

- 3.9 Screw on new fastening nut and tighten.
Counter the fastening screw while doing this.
Tightening torque 70 Nm (52 ftlb.)
Torque angle +90°

- 3.10 Repeat the procedure on the **other side of the vehicle**.

- 3.11 Fill the air spring system using the PIWIS Tester \Rightarrow *Workshop Manual '430117 Bleeding and filling the levelling system'*.

- 4 Install front wheel at the left and right \Rightarrow *Workshop Manual '440519 Removing and installing wheel'*.

- 5 Lower the vehicle and remove it from the lifting platform.

- 6 Enter the campaign in the Warranty and Maintenance booklet.

End of action required

For warranty processing, see **General information on warranty processing** and **Scope 10** under \Rightarrow *Technical Information '440519 Warranty processing'*.

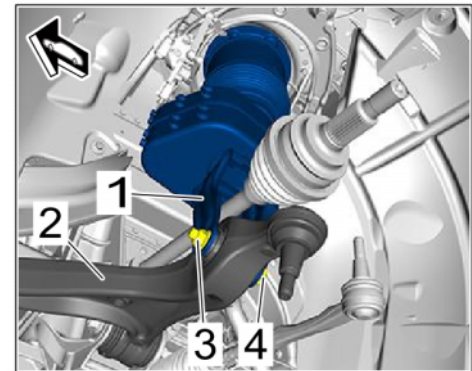

Air-spring strut fork

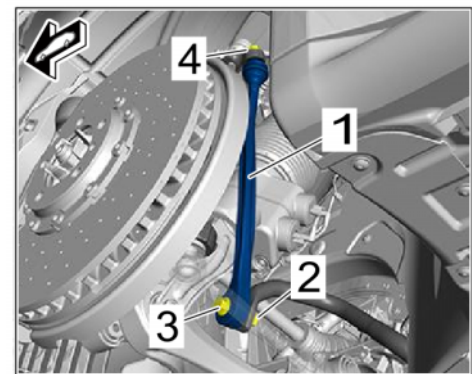

Connecting link for anti-roll bar

Scope 11: Reworking threaded joints on the rear axle

Parts Info: **Parts required for this scope:**

Part No.	Designation – Use	Qty.
PAF909664	⇒ Lock nut, M12 x 1.5 – Lower trailing arm to rear axle housing – Lower trailing arm to wheel bearing housing	4 ea.
N 10696901	⇒ Hexagon flange bolt, M12 x 1.5 x 120 x 90 – Lower trailing arm to rear axle housing	2 ea.
N 10695901	⇒ Hexagon-head bolt, M12 x 1.5 x 105 – Lower trailing arm to wheel bearing housing	2 ea.



Information

For all other parts that may be required, see Porsche Electronic Parts Catalogue (PET).

- Work Procedure: 1 Read and observe general warning notes for working on the high-voltage vehicle electrical system ⇒ *Workshop Manual '2X00IN General warning notes for working on the high-voltage system'*.
- 2 Isolate the high-voltage system from the power supply and complete the relevant documentation ⇒ *Workshop Manual '2X00IN Isolating high-voltage system from power supply/Starting high-voltage system'*.
- 3 Remove high-voltage battery ⇒ *Workshop Manual '270819 Removing and installing high-voltage battery'*.
- 4 Replace the following threaded connections on the **rear axle at the left and right**:
- **Front threaded joint securing lower trailing arms to rear axle housing**
 - **Threaded joint securing lower trailing arms to wheel bearing housing on the rear axle**

Also only for vehicles that have already been delivered to customers: After removing the relevant bolts, perform a **visual inspection** for **signs of damage caused by driving** in the area around the relevant screw points.
The **relevant components may also have to be replaced**, depending on the result of the check.

- 4.1 **Loosen and remove front** fastening nut ⇒ *Lower trailing arm on the rear axle -4-* and screw ⇒ *Lower trailing arm on the rear axle -3-* on lower trailing arm ⇒ *Lower trailing arm on the rear axle -1-* on the rear axle housing. Then insert a new fastening screw and secure with a new fastening nut.

For instructions, see ⇒ *Workshop Manual '421119 Removing and installing trailing arm'*.

Please note: Threaded joint ⇒ *Lower trailing arm on the rear axle -9, 10-* on shock absorber ⇒ *Lower trailing arm on the rear axle -7-* or connecting link ⇒ *Lower trailing arm on the rear axle -8-* is **not affected** and must not be loosened.

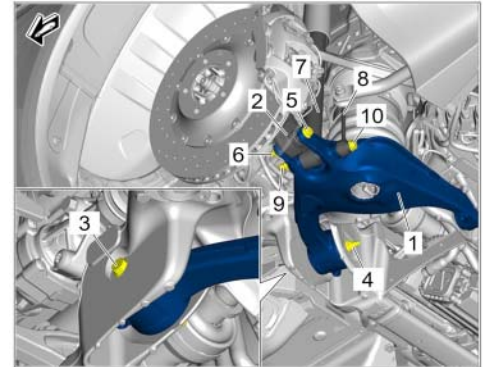

Lower trailing arm on the rear axle

- 4.2 Loosen and remove fastening nut ⇒ *Lower trailing arm on the rear axle -6-* and screw ⇒ *Lower trailing arm on the rear axle -5-* from lower trailing arm ⇒ *Lower trailing arm on the rear axle -1-* on wheel bearing housing ⇒ *Lower trailing arm on the rear axle -2-*. Then insert a new fastening screw and secure with a new fastening nut. For instructions, see ⇒ *Workshop Manual '421119 Removing and installing trailing arm'*.
- 4.3 Repeat the procedure on the **other side of the vehicle**.
- 5 Install high-voltage battery ⇒ *Workshop Manual '270819 Removing and installing high-voltage battery'*.
- 6 Start the high-voltage system and complete the relevant documentation ⇒ *Workshop Manual '2X00IN Isolating high-voltage system from power supply/Starting high-voltage system'*.
- 7 Enter the campaign in the Warranty and Maintenance booklet.

End of action required

For warranty processing, see **General information on warranty processing** and **Scope 11** under ⇒ *Technical Information '2X00IN Warranty processing'*.

Scope 12: Reworking threaded joints on the rear axle

Parts Info: **Parts required for this scope:**

Part No.	Designation – Use	Qty.
PAF909664	⇒ Lock nut, M12 x 1.5 – Upper longitudinal arm to rear axle housing – Upper longitudinal arm to wheel bearing housing – Upper trailing arm to rear axle housing – Upper trailing arm to wheel bearing housing	8 ea.
N 10628601	⇒ Hexagon-head bolt, M12 x 1.5 x 75 – Upper longitudinal arm to rear axle housing – Upper longitudinal arm to wheel bearing housing – Upper trailing arm to rear axle housing – Upper trailing arm to wheel bearing housing	8 ea.



Information

For all other parts that may be required, see Porsche Electronic Parts Catalogue (PET).

Work Procedure: 1 Raise the vehicle using a lifting platform ⇒ *Workshop Manual '4X00IN Lifting the vehicle'*.

2 Remove rear wheel at the left and right ⇒ *Workshop Manual '440519 Removing and installing wheel'*.

3 Replace the following threaded connections on the **rear axle at the left and right**:

- **Threaded joint securing (front) upper longitudinal arm to rear axle housing**
- **Threaded joint securing (front) upper longitudinal arm to wheel bearing housing**
- **Threaded joint securing (rear) upper trailing arm to rear axle housing**
- **Threaded joint securing (rear) upper trailing arm to wheel bearing housing**

Also only for vehicles that have already been delivered to customers: After removing the relevant bolts, perform a **visual inspection** for **signs of damage caused by driving** in the area around the relevant screw points.

The **relevant components may also have to be replaced**, depending on the result of the check.

3.1 Remove (front) upper longitudinal arm from rear axle housing and wheel bearing housing ⇒ *Workshop Manual '423519 Removing and installing upper control arm (front)'*.

3.2 Install (front) upper longitudinal arm using new fastening nuts and screws ⇒ *Workshop Manual '423519 Removing and installing upper control arm (front)'*.

3.3 Remove (rear) upper trailing arm from rear axle housing and wheel bearing housing ⇒ *Workshop Manual '423519 Removing and installing upper control arm (rear)'*.

3.4 Install (rear) upper trailing arm using new fastening nuts and screws ⇒ *Workshop Manual '423519 Removing and installing upper control arm (rear)'*.

- 3.5 Repeat the procedure on the **other side of the vehicle**.
- 4 Install rear wheel at the left and right ⇒ *Workshop Manual '440519 Removing and installing wheel'*.
- 5 Lower the vehicle and remove it from the lifting platform.
- 6 Enter the campaign in the Warranty and Maintenance booklet.

End of action required

For warranty processing, see **General information on warranty processing** and **Scope 12** under ⇒ *Technical Information '440519 Warranty processing'*.

Scope 13: Reworking threaded joints on front and rear axle

Parts Info: **Parts required for this scope:**

Part No.	Designation – Use	Qty.
PAF909664	⇒ Lock nut, M12 x 1.5 – Upper longitudinal arm to rear axle housing – Upper longitudinal control arm to wheel bearing housing – Upper trailing arm to rear axle housing – Upper trailing arm to wheel bearing housing – Spring strut to wishbone – Connecting link to anti-roll bar	12 ea.
N 10628601	⇒ Hexagon-head bolt, M12 x 1.5 x 75 – Upper longitudinal arm to rear axle housing – Upper longitudinal arm to wheel bearing housing – Upper trailing arm to rear axle housing – Upper trailing arm to wheel bearing housing	8 ea.
PAF108544	⇒ Lens-head screw, M12 x 1.5 x 90 – Spring strut to wishbone	2 ea.
N 10793603	⇒ Hexagon-head bolt, M12 x 1.5 x 60 – Connecting link to anti-roll bar	2 ea.



Information

For all other parts that may be required, see Porsche Electronic Parts Catalogue (PET).

Work Procedure: 1 Raise the vehicle using a lifting platform ⇒ *Workshop Manual '4X00IN Lifting the vehicle'*.

2 Remove all wheels ⇒ *Workshop Manual '440519 Removing and reinstalling wheel'*.

3 Replace the following threaded connections on the **front axle at the left and right**:

- **Threaded joint securing spring strut to lower trailing arm on the front axle**
- **Threaded joint securing connecting link to anti-roll bar on the front axle**

Also only for vehicles that have already been delivered to customers: After removing the relevant bolts, perform a **visual inspection** for **signs of damage caused by driving** in the area around the relevant screw points.

The **relevant components may also have to be replaced**, depending on the result of the check.

3.1 Release air from and fill air into front air springs at the left and right using the PIWIS Tester ⇒ *Workshop Manual '430117 Bleeding and filling the levelling system'*.

3.2 Support the wheel bearing housing using a suitable engine and gearbox jack. On vehicles with PCCB brake discs, make sure not to damage the brake disc.

3.3 Loosen and unscrew fastening nut ⇒ *Air-spring strut fork -3-* on spring strut fork ⇒ *Air-spring strut fork -1-*.
Counter fastening screw ⇒ *Air-spring strut fork -4-* while doing this. Then remove the fastening screw.

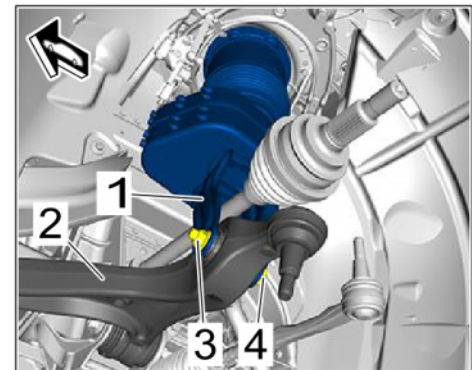

Air-spring strut fork

3.4 Insert a new fastening screw into spring strut fork ⇒ *Air-spring strut fork -1-* and lower trailing arm ⇒ *Air-spring strut fork -2-*.

3.5 Screw on new fastening nut and tighten.
Counter the fastening screw while doing this.
Tightening torque 90 Nm (67 ftlb.)
Torque angle +120°

3.6 Lower the engine and gearbox jack and remove it.

3.7 Loosen and unscrew fastening nut ⇒ *Connecting link for anti-roll bar -2-* from connecting link ⇒ *Connecting link for anti-roll bar -1-* to anti-roll bar.
Counter fastening screw ⇒ *Connecting link for anti-roll bar -3-* while doing this. Then remove the fastening screw.

Please note: Fastening nut \Rightarrow *Connecting link for anti-roll bar -4-* is **not affected** and must not be loosened.

- 3.8 Insert new fastening screw into the anti-roll bar and connecting link.
- 3.9 Screw on new fastening nut and tighten. Counter the fastening screw while doing this.
Tightening torque 70 Nm (52 ftlb.)
Torque angle +90°

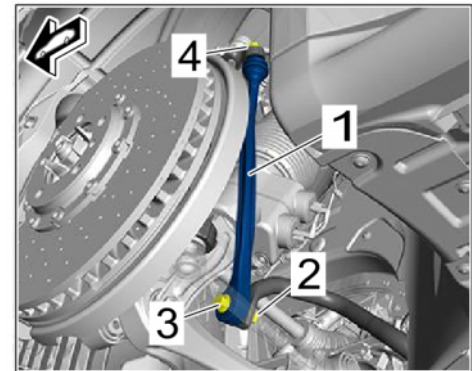

Connecting link for anti-roll bar

- 3.10 Repeat the procedure on the **other side of the vehicle**.
- 3.11 Fill the air spring system using the PIWIS Tester \Rightarrow *Workshop Manual '430117 Bleeding and filling the levelling system'*.

- 4 Replace the following threaded connections on the **rear axle at the left and right**:
 - **Threaded joint securing (front) upper longitudinal arm to rear axle housing**
 - **Threaded joint securing (front) upper longitudinal arm to wheel bearing housing**
 - **Threaded joint securing (rear) upper trailing arm to rear axle housing**
 - **Threaded joint securing (rear) upper trailing arm to wheel bearing housing**

Also only for vehicles that have already been delivered to customers: After removing the relevant bolts, perform a **visual inspection** for **signs of damage caused by driving** in the area around the relevant screw points.

The **relevant components may also have to be replaced**, depending on the result of the check.

- 4.1 Remove (front) upper longitudinal arm from rear axle housing and wheel bearing housing \Rightarrow *Workshop Manual '423519 Removing and installing upper control arm (front)'*.
- 4.2 Install (front) upper longitudinal arm using new fastening nuts and screws \Rightarrow *Workshop Manual '423519 Removing and installing upper control arm (front)'*.
- 4.3 Remove (rear) upper trailing arm from rear axle housing and wheel bearing housing \Rightarrow *Workshop Manual '423519 Removing and installing upper control arm (rear)'*.
- 4.4 Install (rear) upper trailing arm using new fastening nuts and screws \Rightarrow *Workshop Manual '423519 Removing and installing upper control arm (rear)'*.
- 4.5 Repeat the procedure on the **other side of the vehicle**.

- 5 Install all wheels \Rightarrow *Workshop Manual '440519 Removing and installing wheel'*.

- 6 Lower the vehicle and remove it from the lifting platform.

- 7 Enter the campaign in the Warranty and Maintenance booklet.

End of action required

For warranty processing, see **General information on warranty processing** and **Scope 13** under \Rightarrow *Technical Information '440519 Warranty processing'*.

Scope 14: Reworking threaded joints on front and rear axle at the right

Parts Info: **Parts required for this scope:**

Part No.	Designation - Use	Qty.
PAF909664	⇒ Lock nut, M12 x 1.5 - Connecting link to front anti-roll bar: - Lower trailing arm to rear wheel bearing housing	2 ea.
N 10793603	⇒ Hexagon-head bolt, M12 x 1.5 x 60 - Connecting link to front anti-roll bar	1 ea.
N 10695901	⇒ Hexagon-head bolt, M12 x 1.5 x 105 - Lower trailing arm to rear wheel bearing housing	1 ea.



Information

For all other parts that may be required, see Porsche Electronic Parts Catalogue (PET).

- Work Procedure:
- 1 Raise the vehicle using a lifting platform ⇒ *Workshop Manual '4X00IN Lifting the vehicle'*.
 - 2 Remove front and rear right wheel ⇒ *Workshop Manual '440519 Removing and installing wheel'*.
 - 3 Replace the following threaded connections on the **right-hand side of the vehicle**:
 - **Threaded joint securing connecting link to anti-roll bar on the front axle**
 - **Threaded joint securing lower trailing arm to wheel bearing housing on the rear axle**

Also only for vehicles that have already been delivered to customers: After removing the relevant bolts, perform a **visual inspection** for **signs of damage caused by driving** in the area around the relevant screw points.

The **relevant components may also have to be replaced**, depending on the result of the check.

- 3.1 Replace threaded joint securing **right** connecting link to anti-roll bar on the **front axle**.
 - 3.1.1 Loosen and unscrew fastening nut ⇒ *Connecting link for anti-roll bar -2-* from connecting link ⇒ *Connecting link for anti-roll bar -1-* to **front** anti-roll bar.
Counter fastening screw ⇒ *Connecting link for anti-roll bar -3-* while doing this.
Then remove the fastening screw.

Please note: Fastening nut \Rightarrow *Connecting link for anti-roll bar -4-* is **not affected** and must not be loosened.

3.1.2 Insert new fastening screw into the anti-roll bar and connecting link.

3.1.3 Screw on new fastening nut and tighten. Counter the fastening screw while doing this.

Tightening torque 70 Nm (52 ftlb.)

Torque angle +90°

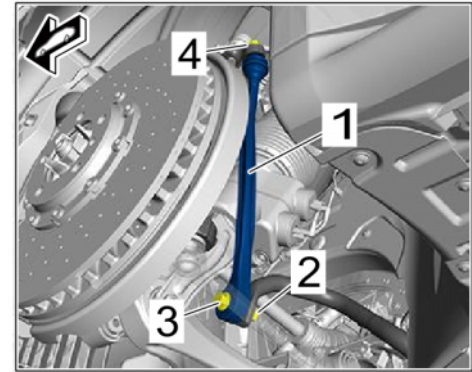

Connecting link for anti-roll bar

3.2 Replace threaded joints on lower **right** trailing arm to wheel bearing housing on the **rear axle**.

3.2.1 Support the wheel bearing housing using a suitable engine and gearbox jack. On vehicles with PCCB brake discs, make sure not to damage the brake disc.

3.2.2 Loosen and unscrew fastening nut \Rightarrow *Lower trailing arm on wheel bearing housing -2-* on lower trailing arm \Rightarrow *Lower trailing arm on wheel bearing housing -1-* to the wheel bearing housing. Counter fastening screw \Rightarrow *Lower trailing arm on wheel bearing housing -3-* while doing this.

3.2.3 Remove fastening screw from the trailing arm/wheel bearing housing and insert a new fastening screw.

3.2.4 Screw on new fastening nut \Rightarrow *Lower trailing arm on wheel bearing housing -2-* and tighten. Counter fastening screw \Rightarrow *Lower trailing arm on wheel bearing housing -3-* while doing this.

Tightening torque 70 Nm

Torque angle +180°

3.2.5 Lower the engine and gearbox jack and remove it.

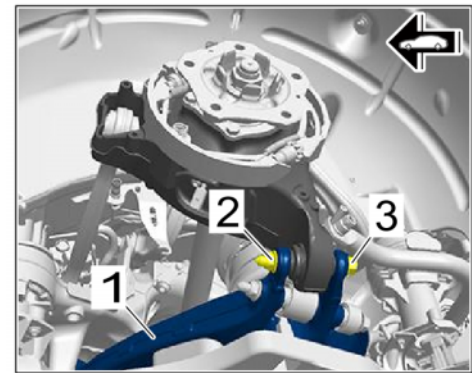

Lower trailing arm on wheel bearing housing

4 Install front and rear right wheel \Rightarrow *Workshop Manual '440519 Removing and installing wheel'*.

5 Lower the vehicle and remove it from the lifting platform.

6 Enter the campaign in the Warranty and Maintenance booklet.

End of action required

For warranty processing, see **General information on warranty processing** and **Scope 14** under ⇒ *Technical Information '440519 Warranty processing'*.

Scope 15: Reworking threaded joint on the left of the rear axle

Parts Info: **Parts required for this scope:**

Part No.	Designation – Use	Qty.
PAF909664	⇒ Lock nut, M12 x 1.5 – Damper/connecting link to lower wishbone	1 ea.
PAF107169	⇒ Hexagon-head bolt, M12 x 1.5 x 170 x 90 – Damper/connecting link to lower wishbone	1 ea.



Information

For all other parts that may be required, see Porsche Electronic Parts Catalogue (PET).

- Work Procedure: 1 Raise the vehicle using a lifting platform ⇒ *Workshop Manual '4X00IN Lifting the vehicle'*.
- 2 Remove rear left wheel ⇒ *Workshop Manual '440519 Removing and installing wheel'*.
- 3 Remove air guide for rear left brake disc ⇒ *Workshop Manual '461619 Removing and installing brake disc air guide (rear)'*.
- 4 Replace the following threaded connection on the **rear axle at the left**:
- **Threaded joint of the shock absorber together with the connecting link to the lower wishbone at the left**

Also only for vehicles that have already been delivered to customers: After removing the relevant bolts, perform a **visual inspection** for **signs of damage caused by driving** in the area around the relevant screw points.
The **relevant components may also have to be replaced**, depending on the result of the check.

- 4.1 Support the wheel bearing housing using a suitable engine and gearbox jack. On vehicles with PCCB brake discs, make sure not to damage the brake disc.

- 4.2 Loosen and remove fastening nut ⇒ *Connecting link for anti-roll bar -2-* and screw ⇒ *Connecting link for anti-roll bar -3-* securing coupling link ⇒ *Connecting link for anti-roll bar -1-* to lower wishbone.

For instructions, see ⇒ *Workshop Manual '429119 Removing and installing connecting link for anti-roll bar'*

Please note: Fastening nut ⇒ *Connecting link for anti-roll bar -4-* is **not affected** and must not be loosened.

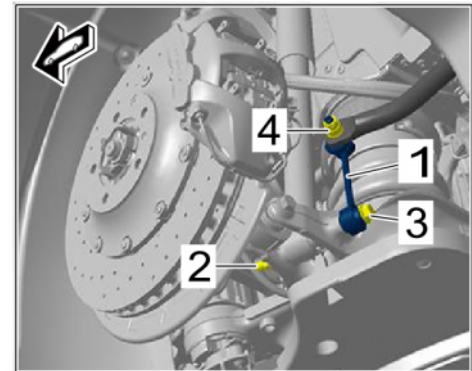

Connecting link for anti-roll bar

- 4.3 Secure coupling link together with the shock absorber to the lower wishbone using a new fastening nut ⇒ *Connecting link for anti-roll bar -2-* and screw ⇒ *Connecting link for anti-roll bar -3-*.

For instructions, see ⇒ *Workshop Manual '429119 Removing and installing connecting link for anti-roll bar'*.

- 4.4 Install (rear) upper trailing arm using new fastening nuts and screws ⇒ *Workshop Manual '423519 Removing and installing upper control arm (rear)'*.

- 4.5 Lower the engine and gearbox jack and remove it.

- 5 Install air guide for rear left brake disc ⇒ *Workshop Manual '461619 Removing and installing brake disc air guide (rear)'*.

- 6 Install rear left wheel ⇒ *Workshop Manual '440519 Removing and installing wheel'*.

- 7 Lower the vehicle and remove it from the lifting platform.

- 8 Enter the campaign in the Warranty and Maintenance booklet.

End of action required

For warranty processing, see **General information on warranty processing** and **Scope 15** under ⇒ *Technical Information '440519 Warranty processing'*.

Scope 16: Reworking threaded joints on the front axle

Parts Info: **Parts required for this scope:**

Part No.	Designation – Use	Qty.
PAF909664	⇒ Lock nut, M12 x 1.5 – Spring strut to wishbone – Steering gear to front-axle carrier	3 ea.

PAF108544	⇒ Lens-head screw, M12 x 1.5 x 90 – Spring strut to wishbone	2 ea.
N 10628301	⇒ Hexagon-head bolt, M12 x 1.5 x 90 – Steering gear to front-axle carrier	1 ea.



Information

For all other parts that may be required, see Porsche Electronic Parts Catalogue (PET).

- Work Procedure: 1 Raise the vehicle using a lifting platform ⇒ *Workshop Manual '4X001N Lifting the vehicle'*.
- 2 Remove front wheel at the left and right ⇒ *Workshop Manual '440519 Removing and installing wheel'*.
- 3 Replace the following threaded connections on the **front axle at the left and right**:
- **Threaded joint securing spring strut to lower trailing arm on the front axle**

Also only for vehicles that have already been delivered to customers: After removing the relevant bolts, perform a **visual inspection** for **signs of damage caused by driving** in the area around the relevant screw points.

The **relevant components may also have to be replaced**, depending on the result of the check.

- 3.1 Release air from and fill air into front air springs at the left and right using the PIWIS Tester ⇒ *Workshop Manual '430117 Bleeding and filling the levelling system'*.
- 3.2 Support the wheel bearing housing using a suitable engine and gearbox jack. On vehicles with PCCB brake discs, make sure not to damage the brake disc.
- 3.3 Loosen and unscrew fastening nut ⇒ *Air-spring strut fork -3-* on spring strut fork ⇒ *Air-spring strut fork -1-*.
Counter fastening screw ⇒ *Air-spring strut fork -4-* while doing this. Then remove the fastening screw.
- 3.4 Insert a new fastening screw into spring strut fork ⇒ *Air-spring strut fork -1-* and lower trailing arm ⇒ *Air-spring strut fork -2-*.
- 3.5 Screw on new fastening nut and tighten.
Counter the fastening screw while doing this.
Tightening torque 90 Nm (67 ftlb.)
Torque angle +120°
- 3.6 Lower the engine and gearbox jack and remove it.

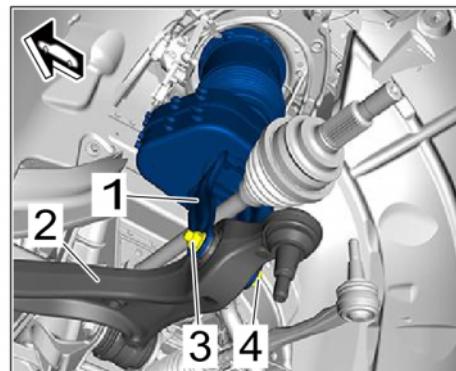

Air-spring strut fork

- 3.7 Loosen and unscrew fastening nut ⇒ *Connecting link for anti-roll bar -2-* from connecting link ⇒ *Connecting link for anti-roll bar -1-* to anti-roll bar.
Counter fastening screw ⇒ *Connecting link for anti-roll bar -3-* while doing this. Then remove the fastening screw.

Please note: Fastening nut ⇒ *Connecting link for anti-roll bar -4-* is **not affected** and must not be loosened.

- 3.8 Insert new fastening screw into the anti-roll bar and connecting link.
- 3.9 Screw on new fastening nut and tighten.
Counter the fastening screw while doing this.
Tightening torque 70 Nm (52 ftlb.)
Torque angle +90°

Repeat the procedure on the **other side of the vehicle**.

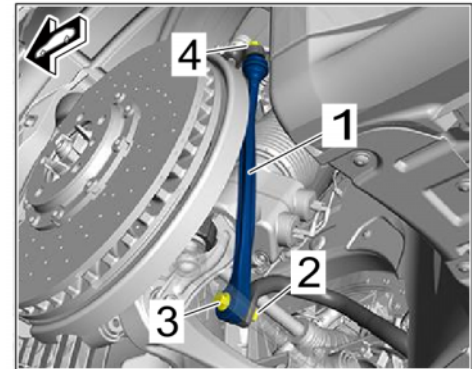

Connecting link for anti-roll bar

- 3.10 Fill the air spring system using the PIWIS Tester ⇒ *Workshop Manual '430117 Bleeding and filling the levelling system'*.
- 4 Replace the following threaded connection on the **front axle at the left**:
- **Threaded joint securing steering gear to front-axle carrier at the left**

Also only for vehicles that have already been delivered to customers: After removing the relevant bolts, perform a **visual inspection** for **signs of damage caused by driving** in the area around the relevant screw points.

The **relevant components may also have to be replaced**, depending on the result of the check.

- 4.1 Remove front axle support (rear section) ⇒ *Workshop Manual '400819 Removing and installing front axle support (rear section)'*.

4.2 Loosen and remove fastening screw ⇒ *Steering gear to front-axle cross member -2- on the left* of the steering gear ⇒ *Steering gear to front-axle cross member -1-*. While doing this, counter the fastening nut on the upper side of the steering gear through the wheel housing.

4.3 Insert new fastening screw and secure with a new fastening nut.

Tightening torque 70 Nm (52 ftlb.)
Torque angle +180°

4.4 Install front axle support (rear section) ⇒ *Workshop Manual '400819 Removing and installing front axle support (rear section)'*.

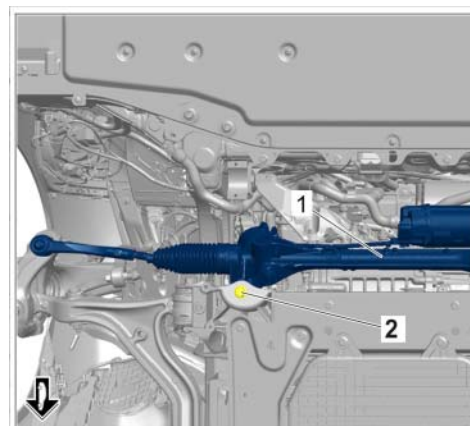

Steering gear to front-axle cross member

5 Install front wheel at the left and right ⇒ *Workshop Manual '440519 Removing and installing wheel'*.

6 Lower the vehicle and remove it from the lifting platform.

7 Enter the campaign in the Warranty and Maintenance booklet.

End of action required

For warranty processing, see **General information on warranty processing** and **Scope 16** under ⇒ *Technical Information '440519 Warranty processing'*.

Scope 17: Reworking threaded joint on the front axle



Information

For all other parts that may be required, see Porsche Electronic Parts Catalogue (PET).

Parts Info: **Parts required for this scope:**

Part No.	Designation – Use	Qty.
PAF909664	⇒ Lock nut, M12 x 1.5 – Front electric drive motor to front-axle module	1 ea.
N 10640301	⇒ Hexagon-head bolt, M12 x 1.5 x 100 x 90 – Front electric drive motor to front-axle module	1 ea.

Work Procedure: 1 Read and observe general warning notes for working on the high-voltage vehicle electrical system ⇒ *Workshop Manual '2X00IN General warning notes for working on the high-voltage system'*.

- 2 Isolate the high-voltage system from the power supply and complete the relevant documentation ⇒ *Workshop Manual '2X00IN Isolating high-voltage system from power supply/Starting high-voltage system'*.
- 3 Drain coolant completely ⇒ *Workshop Manual '193817 Draining and filling coolant'*.
- 4 Drain refrigerant.
⇒ *Workshop Manual '870317 Draining and filling refrigerant R134a'*
⇒ *Workshop Manual '870317 Draining and filling refrigerant R1234yf'*
- 5 Replace the following threaded connection on the **front axle at the left**:
 - **Threaded joint securing electric drive motor to front-axle module at the front left**

Also only for vehicles that have already been delivered to customers: After removing the relevant bolts, perform a **visual inspection** for **signs of damage caused by driving** in the area around the relevant screw points.

The **relevant components may also have to be replaced**, depending on the result of the check.

- 5.1 Remove front-axle module ⇒ *Workshop Manual '400119 Removing and installing front axle'*.
- 5.2 Loosen and unscrew fastening nut **at the front left** ⇒ *Front electric drive motor to front-axle module -2-* of electric drive motor ⇒ *Front electric drive motor to front-axle module -1-*. Counter fastening screw ⇒ *Front electric drive motor to front-axle module -3-* while doing this.
Then remove the fastening screw.
- 5.3 Insert new fastening screw ⇒ *Front electric drive motor to front-axle module -3-* and secure using a new fastening nut ⇒ *Front electric drive motor to front-axle module -2-*.
Initial tightening 70 Nm (52 ftlb.)
Final tightening torque angle 90°
- 5.4 Install front-axle module ⇒ *Workshop Manual '400119 Removing and installing front axle'*.

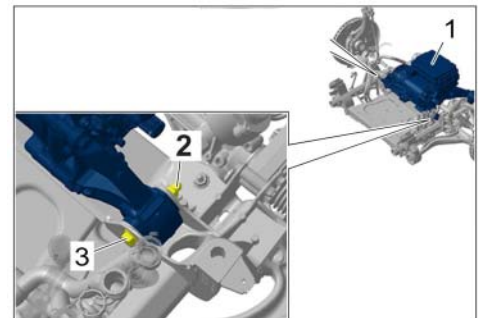

*Front electric drive motor
to front-axle module*

- 6 Fill in refrigerant.
⇒ *Workshop Manual '870317 Draining and filling refrigerant R134a'*
⇒ *Workshop Manual '870317 Draining and filling refrigerant R1234yf'*
- 7 Fill in coolant and bleed the cooling system ⇒ *Workshop Manual '193817 Draining and filling coolant'*.
- 8 Start the high-voltage system and complete the relevant documentation ⇒ *Workshop Manual '2X00IN Isolating high-voltage system from power supply/Starting high-voltage system'*.

- 9 Align the entire vehicle suspension and adjust, if necessary.
 ⇒ *Workshop Manual '449503 Performing front and rear suspension alignment'*
 ⇒ *Workshop Manual '4495TW Adjustment values for suspension alignment'*
- 10 Enter the campaign in the Warranty and Maintenance booklet.

End of action required

For warranty processing, see **General information on warranty processing** and **Scope 17** under ⇒ *Technical Information '4495TW Warranty processing'*.

Scope 18: Reworking threaded joints on front and rear axle

Parts Info: **Parts required for this scope:**

Part No.	Designation – Use	Qty.
PAF909664	⇒ Lock nut, M12 x 1.5 – Front spring strut to wishbone – Lower trailing arm to rear axle housing	4 ea.
PAF108544	⇒ Lens-head screw, M12 x 1.5 x 90 – Spring strut to wishbone	2 ea.
N 10696901	⇒ Hexagon-head bolt, M12 x 1.5 x 120 x 90 – Lower trailing arm to rear axle housing	2 ea.



Information

For all other parts that may be required, see Porsche Electronic Parts Catalogue (PET).

- Work Procedure:
- 1 Read and observe general warning notes for working on the high-voltage vehicle electrical system ⇒ *Workshop Manual '2X00IN General warning notes for working on the high-voltage system'*.
 - 2 Raise the vehicle using a lifting platform ⇒ *Workshop Manual '4X00IN Lifting the vehicle'*.
 - 3 Remove front wheel at the left and right ⇒ *Workshop Manual '440519 Removing and installing wheel'*.
 - 4 Replace the following threaded connections on the **front axle at the left and right**:
 - **Threaded joint securing spring strut to lower trailing arm on the front axle**

Also only for vehicles that have already been delivered to customers: After removing the relevant bolts, perform a **visual inspection** for **signs of damage caused by driving** in the area around the relevant screw points.

The **relevant components may also have to be replaced**, depending on the result of the check.

- 4.1 Release air from and fill air into front air springs at the left and right using the PIWIS Tester ⇒ *Workshop Manual '430117 Bleeding and filling the levelling system'*.
- 4.2 Support the wheel bearing housing using a suitable engine and gearbox jack. On vehicles with PCCB brake discs, make sure not to damage the brake disc.
- 4.3 Loosen and unscrew fastening nut ⇒ *Air-spring strut fork -3-* on spring strut fork ⇒ *Air-spring strut fork -1-*. Counter fastening screw ⇒ *Air-spring strut fork -4-* while doing this. Then remove the fastening screw.
- 4.4 Insert a new fastening screw into spring strut fork ⇒ *Air-spring strut fork -1-* and lower trailing arm ⇒ *Air-spring strut fork -2-*.
- 4.5 Screw on new fastening nut and tighten. Counter the fastening screw while doing this.
Tightening torque 90 Nm (67 ftlb.)
Torque angle +120°
- 4.6 Lower the engine and gearbox jack and remove it.
- 4.7 Repeat the procedure on the **other side of the vehicle**.
- 4.8 Fill the air spring system using the PIWIS Tester ⇒ *Workshop Manual '430117 Bleeding and filling the levelling system'*.

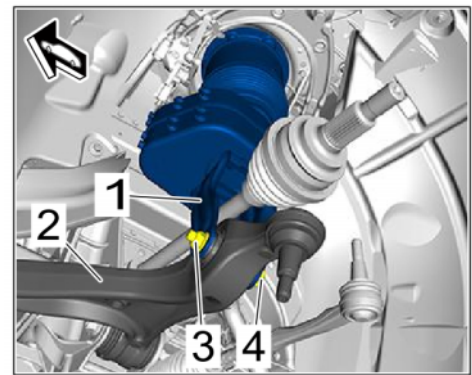

Air-spring strut fork

- 5 Isolate the high-voltage system from the power supply and complete the relevant documentation ⇒ *Workshop Manual '2X00IN Isolating high-voltage system from power supply/Starting high-voltage system'*.
- 6 Remove high-voltage battery ⇒ *Workshop Manual '270819 Removing and installing high-voltage battery'*.
- 7 Replace the following threaded connections on the **rear axle at the left and right**:
 - **Front threaded joint securing lower trailing arms to rear axle housing**

Also only for vehicles that have already been delivered to customers: After removing the relevant bolts, perform a **visual inspection** for **signs of damage caused by driving** in the area around the relevant screw points.

The **relevant components may also have to be replaced**, depending on the result of the check.

- 7.1 **Loosen and remove front** fastening nut ⇒ *Lower trailing arm on the rear axle -4-* and screw ⇒ *Lower trailing arm on the rear axle -3-* on lower trailing arm ⇒ *Lower trailing arm on the rear axle -1-* on the rear axle housing. Then insert a new fastening screw and secure with a new fastening nut.
For instructions, see ⇒ *Workshop Manual '421119 Removing and installing trailing arm'*.
Please note: All other threaded joints shown ⇒ *Lower trailing arm on the rear axle -5-10-* are **not affected** and must not be loosened.

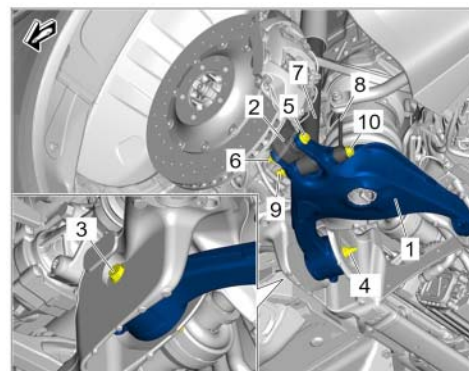

Lower trailing arm on the rear axle

- 7.2 Repeat the procedure on the **other side of the vehicle**.

- 8 Install high-voltage battery ⇒ *Workshop Manual '270819 Removing and installing high-voltage battery'*.
- 9 Start the high-voltage system and complete the relevant documentation ⇒ *Workshop Manual '2X00IN Isolating high-voltage system from power supply/Starting high-voltage system'*.
- 10 Enter the campaign in the Warranty and Maintenance booklet.

End of action required

For warranty processing, see **General information on warranty processing** and **Scope 11** under ⇒ *Technical Information '2X00IN Warranty processing'*.

Warranty processing

Information: **General information on warranty processing**

Each VIN is clearly assigned just one campaign scope to be performed in PCSS. The scopes listed for this measure **do not include published labor time and they only provide the minimum number of parts for reworking the respective vehicles. For this unique business case** all labor and any additional parts that may be required depending on the result of a campaign scope check **must** be submitted as a subsequent credit appeal to the initial paid campaign line. Any additional parts and labor added to the initial AMA3 campaign line that is not a part of the published scope will result in a system error preventing the claim from processing. Due to this unique business case, the campaign scope must be submitted and paid first, then a credit for additional parts and labor thereafter.

Scope: **Scope 1 – Scope 9: Not relevant** for this vehicle type.

Scope 10: **Reworking threaded joints on the front axle**

Working time:		
Reworking threaded joints on the front axle		Labor time: 0 TU
Parts required:		
PAF909664	Lock nut, M12 x 1.5	4 ea.
PAF108544	Lens-head screw, M12 x 1.5 x 90	2 ea.
N 10793603	Hexagon-head bolt, M12 x 1.5 x 60	2 ea.
⇒ Damage Code AMA3 099 000 2		

Scope 11: **Reworking threaded joints on the rear axle**

Working time:		
Reworking threaded joints on the rear axle		Labor time: 0 TU
Parts required:		
PAF909664	Lock nut, M12 x 1.5	4 ea.
N 10696901	Hexagon flange bolt, M12 x 1.5 x 120 x 90	2 ea.
N 10695901	Hexagon-head bolt, M12 x 1.5 x 105	2 ea.
⇒ Damage Code AMA3 099 000 2		

Scope 12: **Reworking threaded joints on the rear axle**

Working time:		
Reworking threaded joints on the rear axle		Labor time: 0 TU
Parts required:		
PAF909664	Lock nut, M12 x 1.5	8 ea.
N 10628601	Hexagon-head bolt, M12 x 1.5 x 75	8 ea.
⇒ Damage Code AMA3 099 000 2		

Scope 13: **Reworking threaded joints on front and rear axle**

Working time:		
Reworking threaded joints on front and rear axle		Labor time: 0 TU
Parts required:		
PAF909664	Lock nut, M12 x 1.5	12 ea.
N 10628601	Hexagon-head bolt, M12 x 1.5 x 75	8 ea.
PAF108544	Lens-head screw, M12 x 1.5 x 90	2 ea.
N 10793603	Hexagon-head bolt, M12 x 1.5 x 60	2 ea.
⇒ Damage Code AMA3 099 000 2		

Scope 14: **Reworking threaded joints on front and rear axle at the right**

Working time:		
Reworking threaded joints on front and rear axle at the right		Labor time: 0 TU
Parts required:		
PAF909664	Lock nut, M12 x 1.5	2 ea.
N 10793603	Hexagon-head bolt, M12 x 1.5 x 60	1 ea.
N 10695901	Hexagon-head bolt, M12 x 1.5 x 105	1 ea.
⇒ Damage Code AMA3 099 000 2		

Scope 15: **Reworking threaded joints on the rear axle**

Working time:		
Reworking threaded joints on the rear axle		Labor time: 0 TU
Parts required:		
PAF909664	Lock nut, M12 x 1.5	1 ea.
PAF107169	Hexagon-head bolt, M12 x 1,5 x 170 x 90	1 ea.
⇒ Damage Code AMA3 099 000 2		

Scope 16: **Reworking threaded joints on the front axle****Working time:**

Reworking threaded joints on the front axle

Labor time: **0 TU****Parts required:**

PAF909664	Lock nut, M12 x 1.5	3 ea.
PAF108544	Lens-head screw, M12 x 1.5 x 90	2 ea.
N 10628301	Hexagon-head bolt, M12 x 1.5 x 90	1 ea.

⇒ **Damage Code AMA3 099 000 2**Scope 17: **Reworking threaded joints on the front axle****Working time:**

Reworking threaded joints on the front axle

Labor time: **0 TU****Parts required:**

PAF909664	Lock nut, M12 x 1.5	1 ea.
N 10640301	Hexagon-head bolt, M12 x 1,5 x 100 x 90	1 ea.

⇒ **Damage Code AMA3 99 000, Repair Code 2**Scope 18: **Reworking threaded joints on front and rear axle****Working time:**

Reworking threaded joints on front and rear axle

Labor time: **0 TU****Parts required:**

PAF909664	Lock nut, M12 x 1.5	4 ea.
PAF108544	Lens-head screw, M12 x 1.5 x 90	2 ea.
N 10696901	Hexagon-head bolt, M12 x 1,5 x 120 x 90	2 ea.

⇒ **Damage Code AMA3 099 000 2**

Important Notice: Technical Bulletins issued by Porsche Cars North America, Inc. are intended only for use by professional automotive technicians who have attended Porsche service training courses. They are written to inform those technicians of conditions that may occur on some Porsche vehicles, or to provide information that could assist in the proper servicing of a vehicle. Porsche special tools may be necessary in order to perform certain operations identified in these bulletins. Use of tools and procedures other than those Porsche recommends in these bulletins may be detrimental to the safe operation of your vehicle, and may endanger the people working on it. Properly trained Porsche technicians have the equipment, tools, safety instructions, and know-how to do the job properly and safely. Part numbers listed in these bulletins are for reference only. The work procedures updated electronically in the Porsche PIWIS diagnostic and testing device take precedence and, in the event of a discrepancy, the work procedures in the PIWIS Tester are the ones that must be followed.

© 2021 Porsche Cars North America, Inc.