



# RECALL CAMPAIGN BULLETIN

|                              |                          |                            |
|------------------------------|--------------------------|----------------------------|
| Classification:<br>EL21-007B | Reference:<br>NTB21-026B | Date:<br>September 9, 2021 |
|------------------------------|--------------------------|----------------------------|

## VOLUNTARY SAFETY RECALL CAMPAIGN 2016-2019 SENTRA; STOP LAMP SWITCH REPLACEMENT

This bulletin has been amended. See **AMENDMENT HISTORY** on the last page.  
Discard all previous versions of this bulletin.

**CAMPAIGN ID #:** PM971  
**APPLIED VEHICLES:** 2016-2019 Sentra (B17)

**Check Service COMM or Dealer Business Systems (DBS)  
National Service History to confirm campaign eligibility.**

### INTRODUCTION

Nissan is conducting this voluntary safety recall campaign, on certain specific model year 2016-2019 Sentra vehicles, to replace the stop lamp switch. This service will be performed at no charge to the customer for parts or labor.

### IDENTIFICATION NUMBER

Nissan has assigned identification number PM971 to this campaign. This number must appear on all communication and documentation of any nature dealing with this campaign.

### DEALER RESPONSIBILITY

It is the dealer's responsibility to check Service COMM or Dealer Business Systems (DBS) National Service History for the campaign status on each vehicle falling within the range of this voluntary safety recall which for any reason enters the service department. This includes vehicles purchased from private parties or presented by transient (tourist) owners and vehicles in a dealer's inventory. **Federal law requires that new vehicles in dealer inventory which are the subject of a safety recall must be corrected prior to sale. Failure to do so can result in civil penalties by the National Highway Traffic Safety Administration.** While federal law applies only to new vehicles, Nissan strongly encourages dealers to correct any used vehicles in their inventory before they are retailed.

Nissan Bulletins are intended for use by qualified technicians, not 'do-it-yourselfers'. Qualified technicians are properly trained individuals who have the equipment, tools, safety instruction, and know-how to do a job properly and safely. **NOTE:** If you believe that a described condition may apply to a particular vehicle, DO NOT assume that it does. See your Nissan dealer to determine if this applies to your vehicle.

## SERVICE PROCEDURE

1. Remove the instrument lower panel LH.
  - For instrument lower panel LH removal, refer to the ESM section below.

➤ **BODY INTERIOR > INSTRUMENT PANEL > REMOVAL AND INSTALLATION > INSTRUMENT LOWER PANEL LH.**

2. Disconnect the harness connector from the stop lamp switch.
3. Rotate the stop lamp switch counterclockwise to remove.

**HINT:** The stop lamp switch is the upper of the 2 switches, as shown in Figure 1.

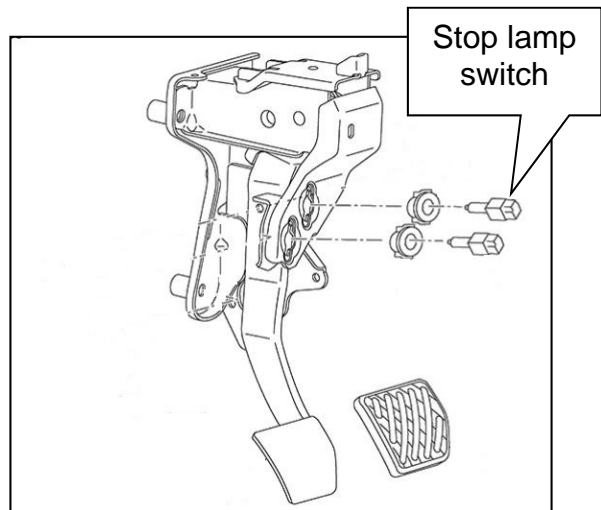

Figure 1

4. Connect the new stop lamp switch, from the **PARTS INFORMATION** table on page 6, to the harness connector (Figure 2).

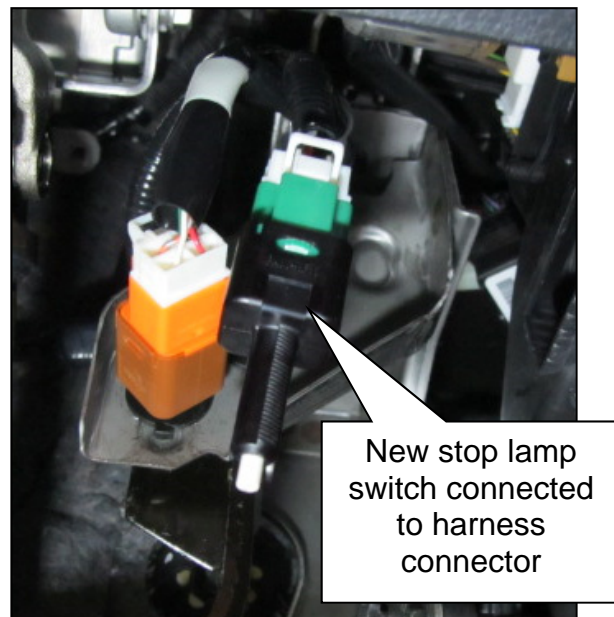

Figure 2

5. Insert the stop lamp switch, plunger first, into the large opening of the rubber grommet until the plunger is visible at the small end of the rubber grommet, as shown in Figure 3.



Figure 3

6. Pull the large opening of the rubber grommet to completely cover the stop lamp switch and harness connector.

**NOTE:** When the rubber grommet is fully installed, the threads of the stop lamp switch will be exposed (Figure 4).

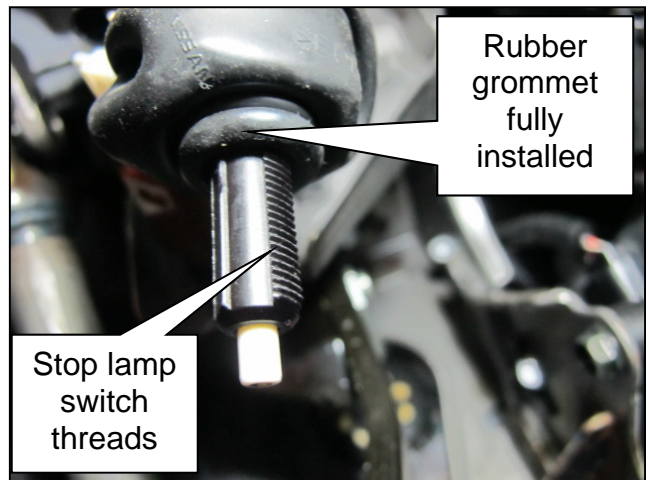

Figure 4

7. Fold the large opening of the grommet back around the stop lamp switch.

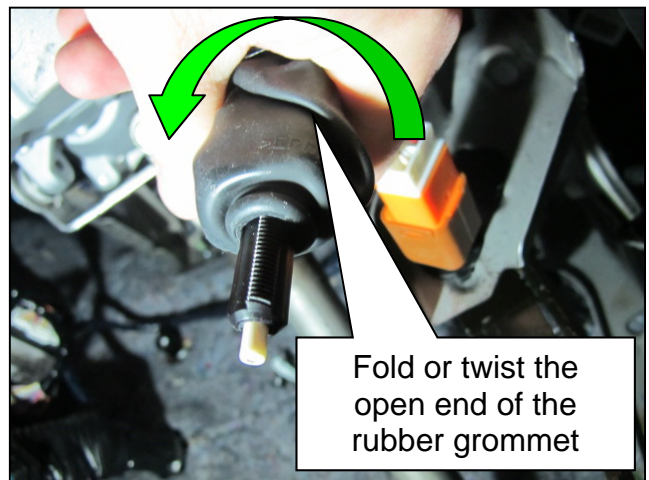

Figure 5

8. Tape off the large opening of the rubber grommet, as shown in Figure 6.

- Ensure the large opening of the rubber grommet is completely sealed off with tape.
- The tape should be applied to the stop lamp switch harness at least 1 inch beyond the end of the rubber grommet.

**NOTE:** Make sure the stop lamp switch threads are exposed.

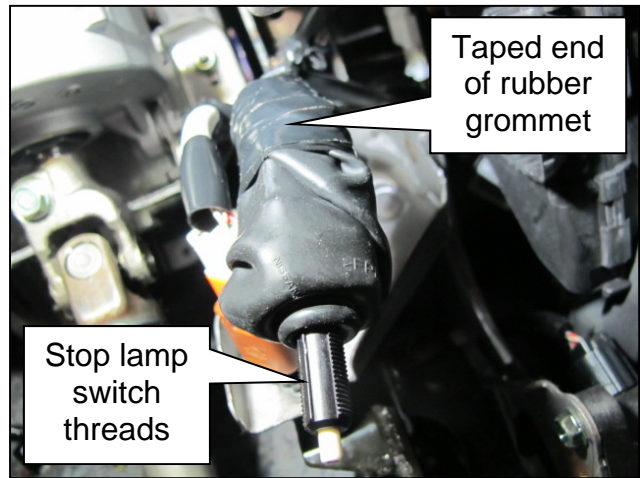

Figure 6

9. Install the stop lamp switch.

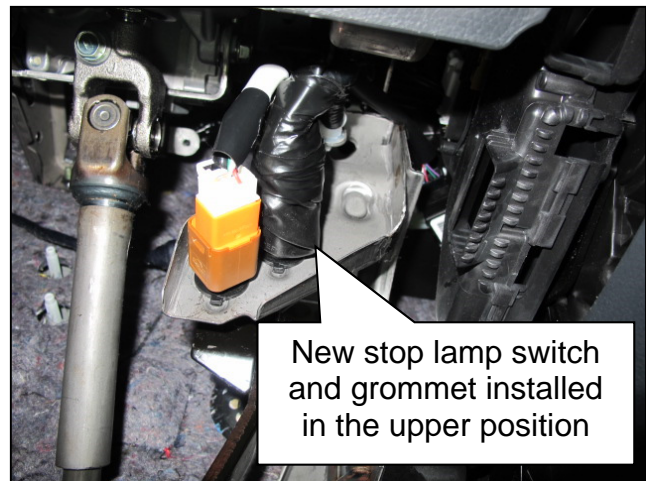

Figure 7

10. Adjust the stop lamp switch.

- For stop lamp switch adjustment, refer to the ESM section below.
  - **BRAKES > BRAKE SYSTEM > PERIODIC MAINTENANCE > BRAKE PEDAL > ADJUSTMENT > STOP LAMP SWITCH AND BRAKE PEDAL POSITION SWITCH**

**IMPORTANT:** Make sure that the clearance (A) between the brake pedal (3) and the brake pedal position switch (1) and the stop lamp switch (2) are within specification. The brake lights must turn OFF when the brake pedal is released.

- Clearance (A): 0.74 – 1.96 mm (0.03 – 0.08 in.)

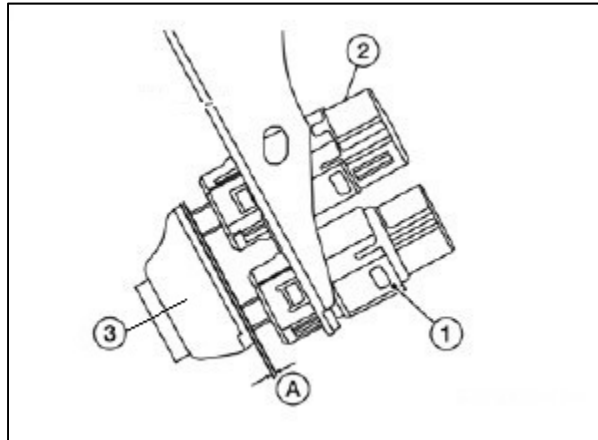

Figure 8

11. Reinstall the instrument lower panel LH.

- For instrument lower panel LH installation, refer to the ESM section below.
  - **BODY INTERIOR > INSTRUMENT PANEL > REMOVAL AND INSTALLATION > INSTRUMENT LOWER PANEL LH**

12. Verify the brake lights operate correctly when the brake pedal is depressed and released.

## PARTS INFORMATION

| DESCRIPTION                 | PART NUMBER                      | QUANTITY |
|-----------------------------|----------------------------------|----------|
| Switch Assembly – Stop Lamp | 25320-9AE0A<br>or<br>25320-AX10A | 1        |
| Rubber Grommet              | 24268-6KE0A                      | 1        |
| Electrical Tape             | (1)                              | 3 ft     |

(1) Local source.

## EXPENSE CODE

| EXPENSE CODE | DESCRIPTION                        | MAX AMOUNT |
|--------------|------------------------------------|------------|
| 060          | Shop Supplies<br>(Electrical Tape) | \$0.08     |

\*The repair requires approximately three feet of tape.

## CLAIMS INFORMATION

Submit a “CM” line claim using the following claims coding:

| CAMPAIGN (“CM”) ID | DESCRIPTION                                     | OP CODE | FRT    |
|--------------------|---|---------|--------|
| PM971              | Install New Stop Lamp Switch and Rubber Grommet | PM9711  | 0.4 hr |

## AMENDMENT HISTORY

| PUBLISHED DATE    | REFERENCE  | DESCRIPTION   |
|-------------------|------------|---|
| March 29, 2021    | NTB21-026  | Original bulletin published   |
| July 22, 2021     | NTB21-026A | <b>REPAIR OVERVIEW</b> removed, <b>SERVICE PROCEDURE</b> revised, <b>CLAIMS INFORMATION</b> updated |
| September 9, 2021 | NTB21-026B | <b>PARTS INFORMATION</b> updated  |