



SIB 16 01 21
RECALL 21V-060 FUEL PUMP REPLACEMENT

2021-03-18

MODEL

Model	Trade Designation	Production Date
K21	R nine T	2013-2014
K25	R 1200 GS, R 1200 GS Adventure	2011-2013
K26	R 1200 RT	2011-2014
K27	R 1200 R	2011-2014
K40	K 1300 S	2011-2014
K42	HP4	2012-2014
K46	S 1000 RR	2011-2014
K47	S 1000 R	2013-2014
K48	K 1600 GT, K 1600 GTL, K 1600 GTL Exclusive	2011-2014

The affected vehicles have been marked with campaign number 0000163900 in AIR.

In order to determine if a specific vehicle is affected by this campaign it will be necessary to verify the vehicle VIN in AIR (Aftersales Information Research). Based on the response of the system, either proceed with the repair or take no further action. Please note, open campaigns or vehicle stops may not appear in DCS Warranty Vehicle Inquiry or sales systems until 24-72 hours after they are announced, therefore AIR is always the recommended method for determining open campaigns and vehicle stops.

NHTSA STATEMENT

Please be reminded that it is a violation of federal law (The Safety Act) for you to sell, lease or deliver any new motorcycle covered by this notification until the recall repair has been performed. This means that dealers may not legally deliver new motorcycles to consumers until they are fixed or use/sell replacement equipment/parts subject to this recall. Note also that substantial civil penalties apply to violations of the Safety Act. Also, you should not sell, lease or deliver any Certified Pre-Owned or used motorcycles subject to a safety recall until the repair is completed. Please follow any special instructions that we provide to you for the return or disposition of recall parts.

SITUATION

In rare cases, a leak with fuel odor may occur from the fuel-pump and, on applicable models, the auxiliary fuel pump.

Letters are being mailed to owners via First Class mail advising them of this recall and asking them to schedule an appointment with an authorized BMW Motorrad dealer to have the fuel pump(s) replaced.

CORRECTION

The fuel pump will be replaced along with the auxiliary pump, if applicable.

PROCEDURE

Replace the fuel pump(s) using repair instructions in AIR applicable to the given motorcycle.

PARTS INFORMATION

Obtain and confirm the part numbers for your specific vehicle by entering the chassis number in ETK which takes into account specific equipment and/or options.

Additional parts like gaskets, hardware and chemicals may be required for the complete repair.

Part Numbers for All Motorcycles *EXCEPT: R 1200 GS Adventure, K25/32:*

16 14 - - - -	Fuel-pump unit (part number, see Electronic Parts Catalogue)
16 11 - - - -	Seal (part number, see Electronic Parts Catalogue)
16 14 7 722 876	Shaped seal
16 12 1 176 918	Hose clamp (if required)

Part Numbers for R 1200 GS Adventure, K25/32 *ONLY*

16 14 7 708 047	Fuel-pump unit
16 11 7 705 637	Flange
16 11 7 677 883	Seal (QTY: 2)
16 14 7 722 876	Shaped seal

WARRANTY INFORMATION

Reimbursement for this repair will be via normal claim entry utilizing the applicable work package information below and the part numbers listed above that apply:

For All Motorcycles *EXCEPT: R 1200 GS Adventure, K25/32*

Defect code

00 00 16 39 00	Replace the fuel-pump unit
----------------	----------------------------

Labor Operation

00 60 386	Replacing fuel-pump unit	Refer to AIR for FRU
+00 60 886	Replacing fuel-pump unit	Refer to AIR for FRU

FRUs includes all repair procedures to complete the task with allowance for necessary ancillary tasks (e.g., visual inspection, lubrication, cleaning parts etc.) and administrative tasks.

Labor operation code 00 60 386 is a Main labor operation. If you are using a Main labor code for another repair, use the Plus code labor operation instead.

For R 1200 GS Adventure, K25/32 *ONLY*

Defect code

00 00 16 39 00	Replace the fuel-pump unit
----------------	----------------------------

Labor Operation

00 60 387	Replacing both fuel-pump units	10 FRU
+00 60 887	Replacing both fuel-pump units	9 FRU

FRUs includes all repair procedures to complete the task with allowance for necessary ancillary tasks (e.g., visual inspection, lubrication, cleaning parts etc.) and administrative tasks.

Labor operation code 00 60 387 is a Main labor operation. If you are using a Main labor code for another repair, use the Plus code labor operation instead.

TREAD Act Reimbursement - Qualifying Prior Customer-Pay Repairs

Note: The following information does not replace the information found in the BMW Motorrad Warranty Policy and Procedure Manual. See sections 5 “Tread Act Customer Reimbursement” & 7 “Claim Entry – Special Situations” for full details.

If your center is presented with a reimbursement request, BMW of North America, LLC will reimburse qualifying customer-pay repairs that were performed on affected vehicles no later than 10 days after the date on which the last owner notification letter was sent out by BMW.

If the customer previously paid for a qualifying repair, verify in AIR that the VIN is affected by the recall campaign and proceed as applicable:

The customer arrives with an affected vehicle to your workshop

- Perform the open Recall repair outlined in this bulletin, regardless of previous repair history.
- If the prior repair qualifies (see below), submit for both the Recall repair and the customer-pay reimbursement (Separate repair line items/separate defect codes).

Or:

The customer only presents your center with a customer-pay invoice for the prior repair

- If the vehicle and the prior repair qualifies (see below), submit for the customer-pay reimbursement portion only.

Customer-pay Invoice Review and Reimbursement Qualification and Procedure

Review and verify that the prior customer-pay invoice (BMW center or independent repair shop) contains a repair that pertains to the recall campaign. Only the repair outlined in the published safety recall service bulletin is eligible for reimbursement.

If this prior repair qualifies, submit a warranty claim for reimbursement:

- Verify in AIR that the VIN was affected by the recall
- Use defect code 85 99 00 45 NA for the amount requested under sublet 03.
- Comment: RECALL 21V-060 FUEL PUMP REPLACEMENT - Reimbursement for allowable expenses that relate to performing the prior qualifying customer-pay repair.
- Use current repair date and mileage for claim submission.
- Retain copies of the customer paid invoice and the current repair invoice in your records.
- Reimburse the customer directly (parts and labor).

Contact warranty via an IDS ticket with any questions.

Retain the original customer pay invoice in your files; this documentation may be requested by BMW during the claim review process.

Note: A repair performed on a non-affected vehicle or the diagnosis and repair of other unrelated issues do not qualify for reimbursement.

This claim submission for the prior customer-pay reimbursement, when it is submitted as outlined under Defect Code 85 99 00 45 NA, **will not close** the Open Safety Recall on the vehicle.

QUESTIONS REGARDING THIS BULLETIN

Technical inquiries	Contact the BMW Technical Support Group via TSARA
Warranty inquiries	Submit an IDS ticket to the Warranty Department
Parts inquiries	Submit an IDS ticket to the Motorrad Parts Department

Supporting Materials

[picture_as_pdf RM_0524_0060386_0000163900_EN.pdf](#)

[picture_as_pdf 16 01 21_RECALL 21V-060 FUEL PUMP REPLACEMENT.pdf](#)

[picture_as_pdf RM_0470_0060387_0000163900_EN.pdf](#)

0524 - S 1000 RR

00 60 386 Replacing fuel-pump unit

Additional work: 46 52 510 Removing and installing the rear-wheel stand special tool (motorcycles without centre stand)

1

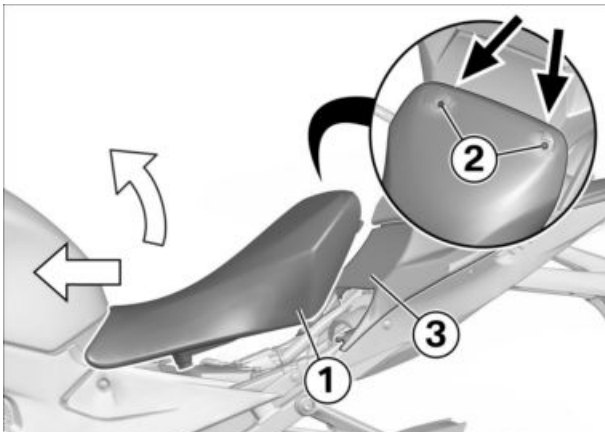

► Removing front seat

- Push front seat **(1)** to one side by applying pressure to the seat surface as shown (**arrows**).
- Remove screws **(2)**.
- Push front seat **(1)** **forward and lift it at the rear to remove**. Take care **not** to allow screws **(2)** to **scratch** trim panel **(3)**.



2

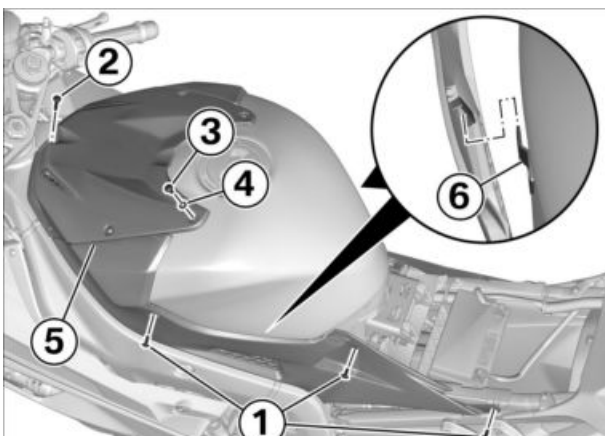

► Removing complete cover of fuel tank

- Remove screws **(1)** on left and right and screw **(2)**.
- Remove screws **(3)** together with washers **(4)** on left and right.
- Remove complete cover **(5)**, noting holders **(6)** on left and right.

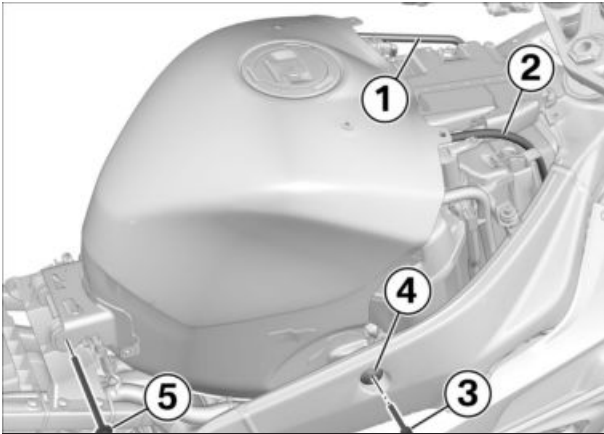

3

► **Removing fuel tank**

- Pull off hoses (1) and (2).
- Remove screws (3) with thrust pieces (4) on the left and right.
- Remove screw with contact disc (5).

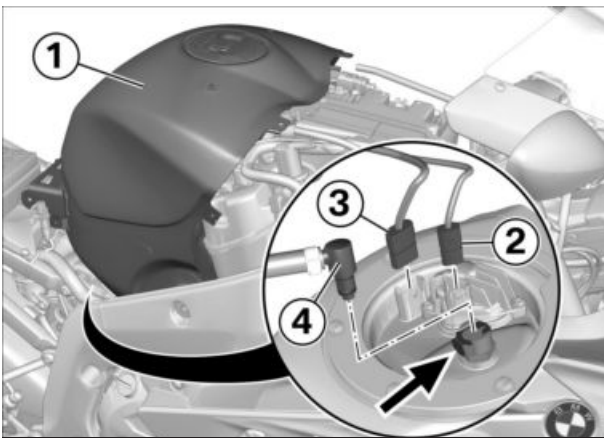

- Lift the fuel tank (1).
- Disconnect plug connection (2) for electric fuel pump and plug connection (3) for fuel level sensor.
- Press open the lock of the fuel delivery line (Arrow) and disconnect fuel delivery line (4).
- Remove fuel tank (1).



- When setting down the fuel tank, make sure that the weight is not applied to the fuel pump.
- » The connector of the fuel pump is protected against damage.

4

► **Draining fuel tank**
⚠ WARNING

Fuel is highly flammable and hazardous to health

Risk of fire, risk of damage to health

- Comply with the safety regulations.

- Drain the fuel tank, using the commercially available special tool.

5

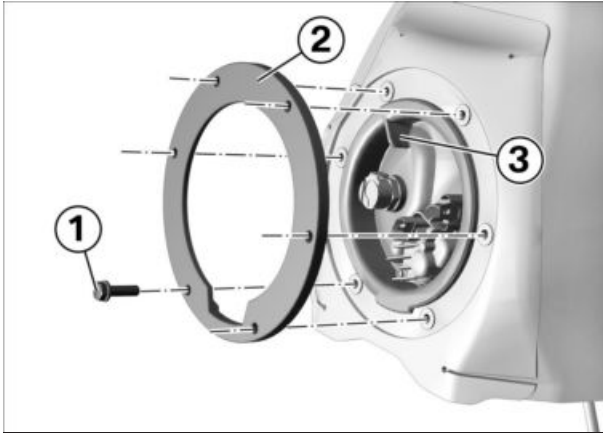

► Removing fuel-pump unit

- Remove screws (1) and remove pressure plate (2).
- By holding the lug (3), carefully ease the fuel-pump unit out of the fuel tank.

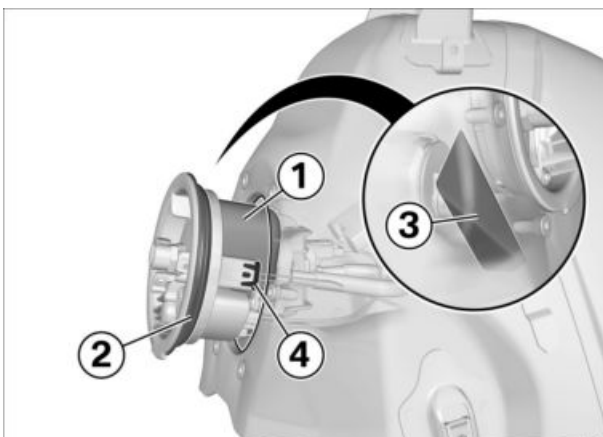

- Remove fuel-pump unit (1) with gasket (2) from the fuel tank, making sure that intake strainer (3) does not catch in the fuel tank and suffer damage.
- Disconnect plug (4) for the lever-type sensor.
- Remove fuel-pump unit (1).

6



► Removing electronic fuel pump

- Remove screws (1).
- Slightly lift electronics module (2) and disconnect plug (3) for the fuel pump.
- Remove electronics module (2) with gasket (4).

7

▶ **Installing electronic fuel pump**▷ **Checking electrical contacts**

- When installing parts that were in use beforehand, check the condition of the electrical contacts.

Check

- Check the electrical contacts of the plug of the fuel-pump electronics.

Result

Significant signs of corrosion on the contacts.

Measure

- Replace the fuel-pump electronics.

Check

- Check the electrical contacts of the fuel-pump unit

Result

Significant signs of corrosion on the contacts.

Measure

- Replacing fuel-pump unit

- Remove all traces of water or moisture inside the cavity and on the plugs.



- Check gasket **(4)** for damage; replace the gasket if damaged or swollen.

- Lubricate gasket **(4)** **thinly**.

**Care products**

Rubber care product	83 12 0 397 018
---------------------	-----------------

- Position gasket **(4)** on electronics module **(2)**.
- Connect plug **(3)** for the fuel pump.
- Carefully install electronics module **(2)**, making sure that seal **(4)** is correctly seated.
- Press electronics module **(2)** with gasket **(4)** all the way into the pump flange, taking care to keep the module square in its recess in the process.
- Engage screws **(1)** and tighten uniformly.



8

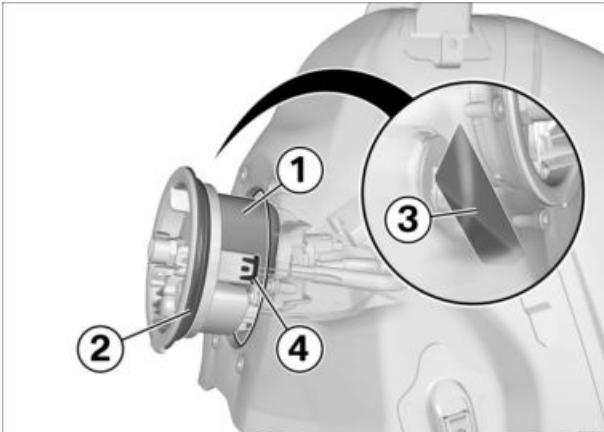

► **Installing fuel-pump unit**

- Check ring (2) for damage; replace if necessary.
- Slip seal (2) onto fuel-pump unit (1).
- Install fuel-pump unit (1).
- Connect plug (4) for the lever-type sensor.
- Install fuel-pump unit (1) with gasket (2) in the fuel tank, making sure that intake strainer (3) does not catch on the fuel tank and that gasket (2) is not damaged.

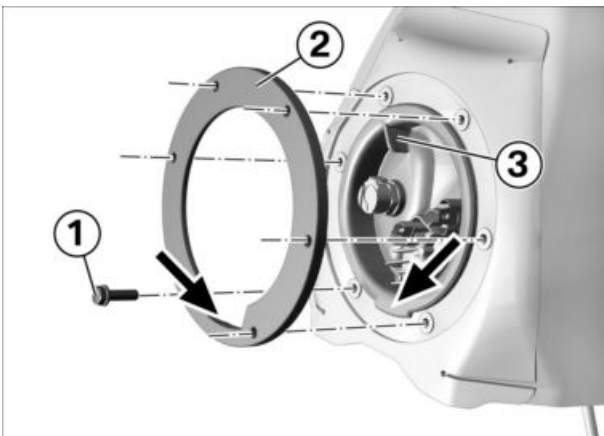

- By holding the lug (3), carefully press the fuel-pump unit into the fuel tank.
- Hold pressure plate (2) in position, making sure that the recesses (arrows) are aligned.
- Install screws (1).

 Tightening torques		
Fuel pump to fuel tank		
M5 x 20	5 Nm	

9

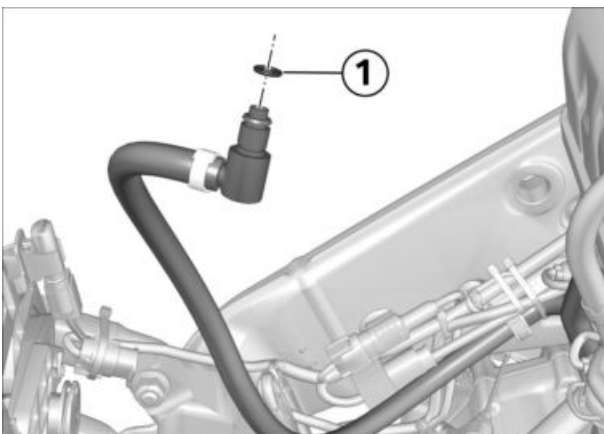

► **Installing fuel tank**

- Check O-ring of fuel delivery line (1) for damage; replace if necessary.

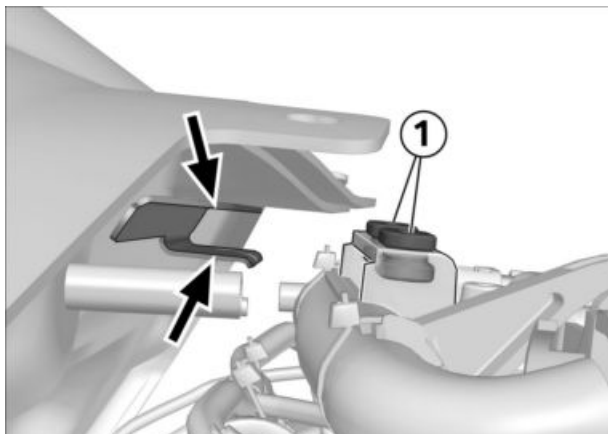

- When installing the fuel tank, make sure that spacer buffers **(1)** are seated in the guide of the fuel tank (**Arrows**).

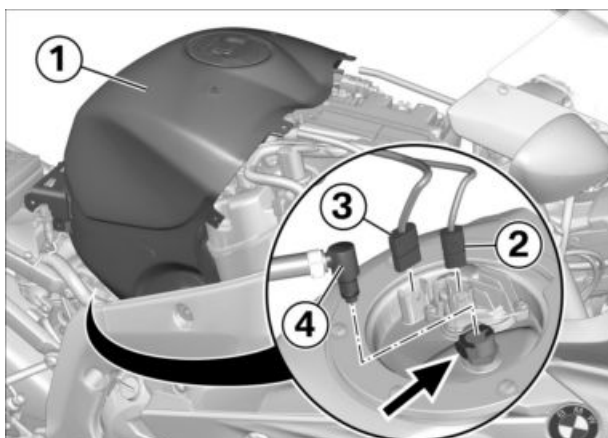

- Position fuel tank **(1)**.

ATTENTION

Application of force to close locked quick-action couplings

Leak due to damaged O-rings

- Close the quick-action coupling of the fuel line only with the latch open/pressed.

- Press open the lock for the fuel delivery line (**Arrow**) and push fuel delivery line **(4)** into the bush with slight pressure. Release the latch and check that the delivery line is correctly seated.

- Connect plug connection **(2)** for electric fuel pump and plug connection **(3)** for fuel level sensor.

- Install fuel tank **(1)**.

- Install bolt with contact disc **(5)**.

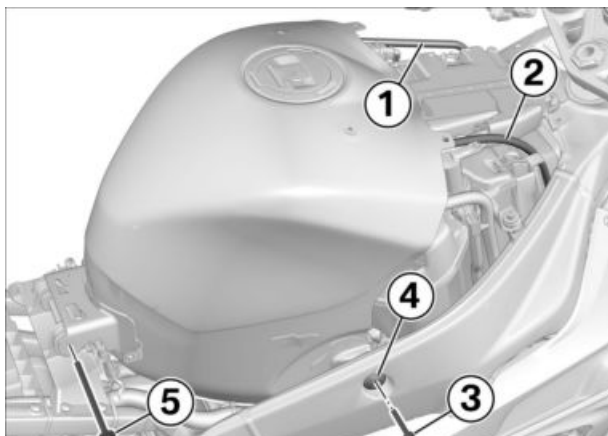

Tightening torques		
Fuel tank to retaining bridge, rear		
M6 x 115	5 Nm	

- Install screws **(3)** with thrust pieces **(4)** on the left and right.

Tightening torques		
Fuel tank, front, to frame		
M6 x 40	5 Nm	

- Push hoses **(1)** and **(2)** on.

10

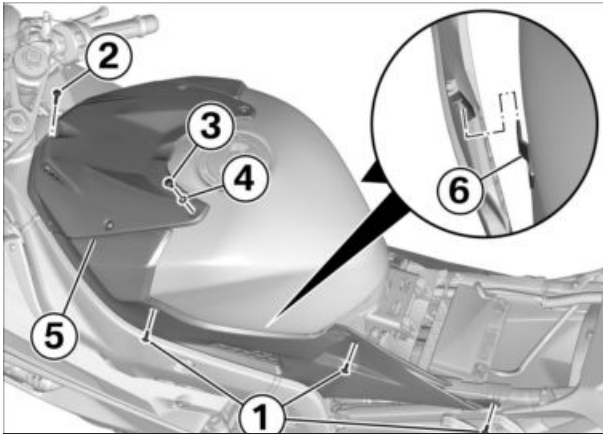
► **Installing complete cover of fuel tank**

- Install complete cover (5), noting holders (6) on left and right.
- Install screws (3) together with washers (4) on left and right.
- Install screws (1) on left and right and screw (2).

11

► **Connecting BMW Motorrad diagnostic system to vehicle**

- Connect the BMW Motorrad battery charger.

 **NOTICE**

When carrying out diagnosis and programming, use a battery charger with 30 A approved by BMW Motorrad that ensures an **on-board system voltage of 13 V**.

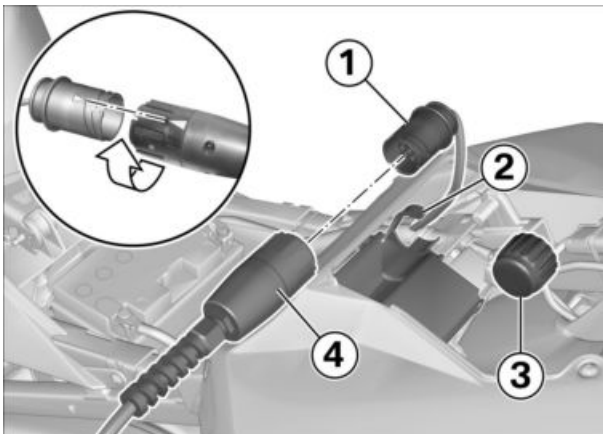

- Disengage diagnosis plug (1) from holder (2) and remove protective cap (3).
- Connect diagnosis connector (1) to connecting cable (4) for the diagnostic system.

 **NOTICE**

See the information about the BMW Motorrad diagnostic system for all further instructions.

12

► **Reading fault memory with BMW Motorrad diagnostic system and resetting adaptation values**
 **NOTICE**

When working with the BMW Motorrad diagnostic system, always follow the instructions it issues.

- Read out the fault memory.

- Perform all requisite repair work.
- Reset the adaptation values.
- Adaptation group in ISTA process "Read/reset adaptation values":
 - » Mixture preparation

13

► Disconnecting BMW Motorrad diagnostic system from motorcycle

- Close all diagnostic programs and switch off the ignition.
- Disconnect the BMW Motorrad diagnostic system from the motorcycle and screw the cap onto the diagnosis plug.
- Disconnect the BMW Motorrad battery charger from the motorcycle.

14

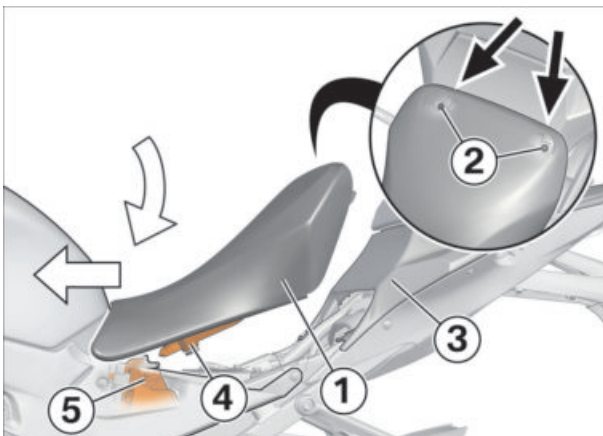

► Installing front seat

- Insert front seat (1) at the front and engage it with seat tray (4) in tank bracket (5).
- Push front seat (1) forward and lower it at the rear to install. Take care not to allow screws (2) to scratch trim panel (3).
- Push front seat (1) to one side by applying pressure to the seat surface as shown (arrows).
- Carefully engage screws (2) and install.

Tightening torques		
Front seat to rear frame		
M5	3 Nm	

15

► Filling fuel tank

⚠ WARNING

Fuel is highly flammable and hazardous to health

Risk of fire, risk of damage to health

- Comply with the safety regulations.

- Fill the fuel tank with fuel.

 Technical data			
Recommended fuel grade		Super unleaded max. 10 % ethanol, E10 95 ROZ/ RON 89 AKI	
Usable fuel capacity		approx. 17.5 l	
Fuel reserve		approx. 4 l	

16

► Final check of work performed

- Check the following:
 - The work as performed achieved the intended purpose.
 - All reservoirs and containers have been filled and all fluids and lubricants are at their correct levels.
 - All threaded fasteners released beforehand have been correctly retightened.
 - The fuel system is free of leaks.
 - The lights and signalling equipment are fully operational and the vehicle is roadworthy.
 - The brake pads of the front and rear brakes are bedded against the brake discs.

▷ Function test, engine start suppression

Check

- Set kill switch to "ON" position.
- Select neutral.
 - » Neutral status indicator light "N" shows.
- Select a gear.
 - » Neutral status indicator light "N" goes out.
- Press the starter button.
 - » Starter does **not** operate.
- Extend the side stand.
 - » Starter does **not** operate.
- Pull the clutch lever.
 - » Starter does **not** operate.
- Press the starter button.
 - » Starter does **not** operate.
- Retract the side stand.
 - » Starter does **not** operate.
- Press the starter button without releasing the clutch lever.
 - » Starter operates.

Result

Not all test steps completed successfully.

Measure

- Check the appropriate parts with the BMW Motorrad diagnostic system.



0470 - R 1200 GS Adventure**00 60 387 Replacing both fuel-pump units****1****▶ Draining fuel tank****⚠ WARNING****Fuel is highly flammable and hazardous to health**

Risk of fire, risk of damage to health

- Comply with the safety regulations.

- Drain the fuel tank, using the commercially available special tool.

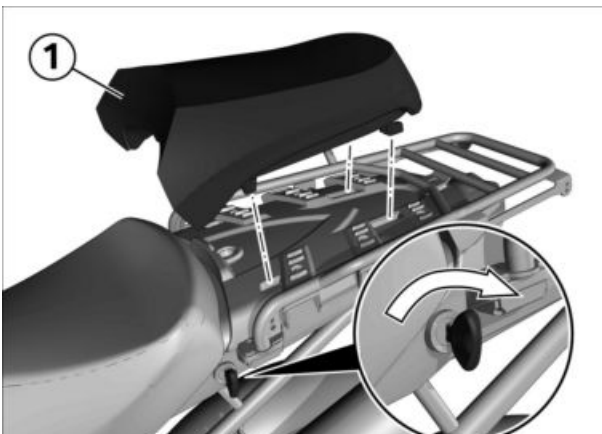
**2****▶ Removing front and rear seats**

- Turn the key clockwise in the seat lock and remove rear seat **(1)**.

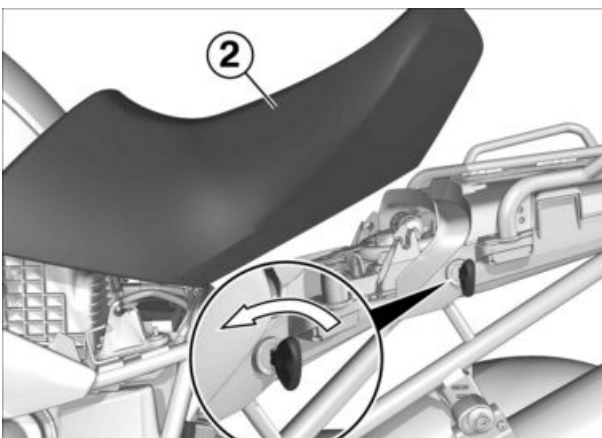

- Turn the key counter-clockwise in the seat lock and remove front seat **(2)**.



3

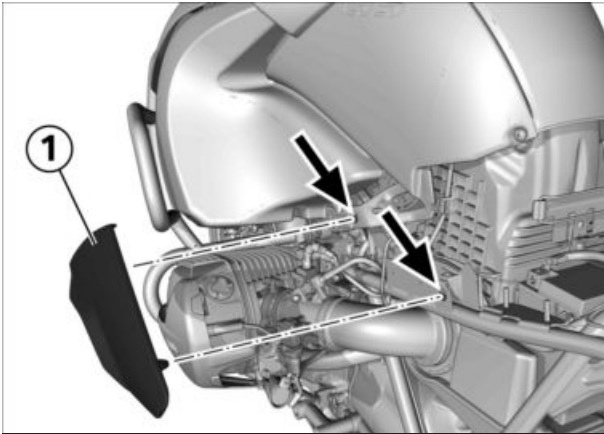

► **Removing left side cover**

- Unclip side cover (1) from the holders (arrows) and remove.



4

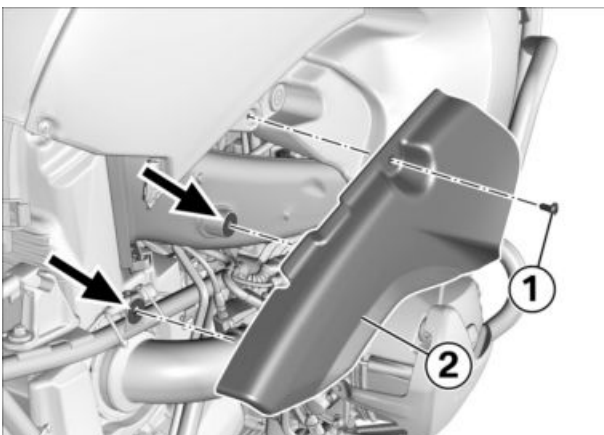

► **Remove the right side cover**

- Remove screw (1).
- Unclip side cover (2) from the holders (arrows) and remove.



5

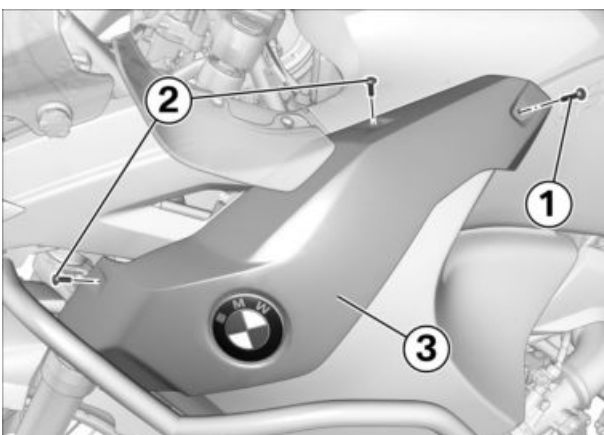

► **Removing side panels**

- Remove screws (1) and (2).
- Remove side panels (3).

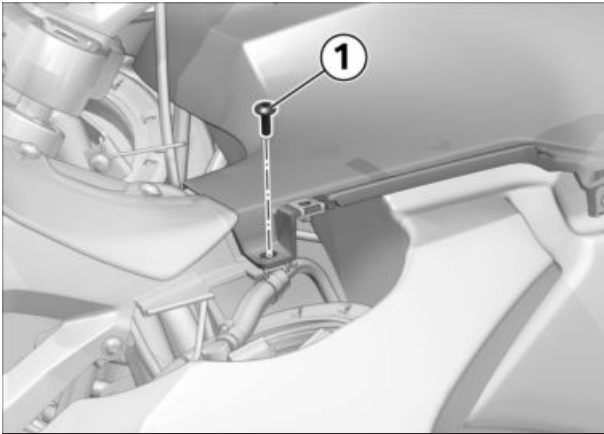

6

► **Removing fuel tank**

- Remove screws **(1)** on left and right.

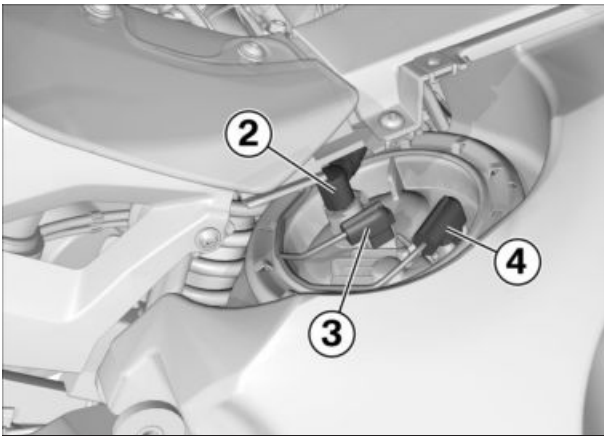
**⚠ WARNING**

Fuel is highly flammable and hazardous to health

Risk of fire, risk of damage to health

- Comply with the safety regulations.

- Disconnect fuel delivery line **(2)**.
- Disconnect connector of electric fuel pump **(3)** and fuel level sensor **(4)**.

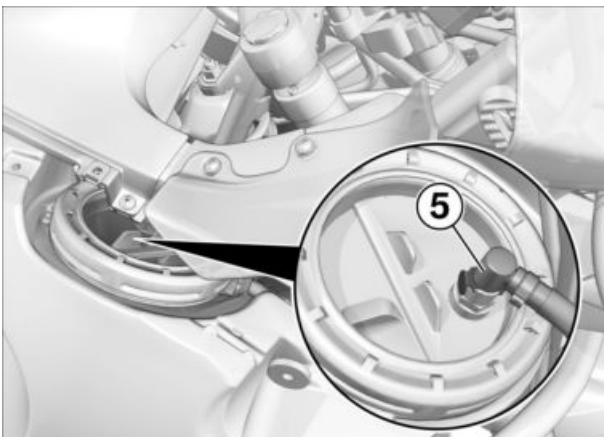

- Disconnect fuel return line **(5)**.

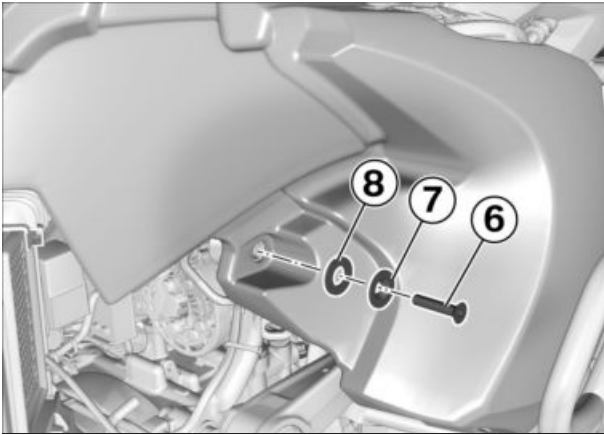

- Remove screws (6) with washers (7) and rubber washers (8) on the left and right.
- Lift the fuel tank.

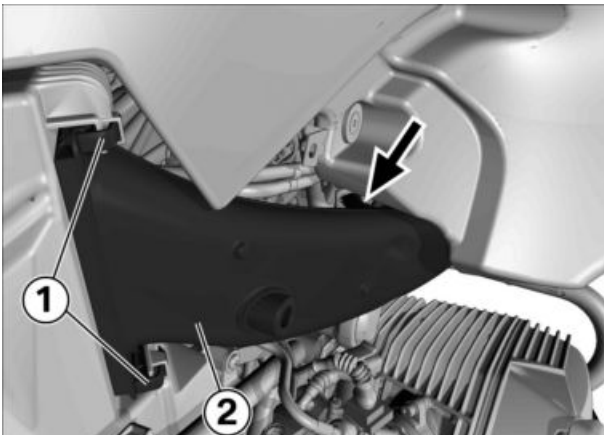

▷ Removing intake air pipe

- Disengage retainer (1) by pressing at rear and remove.
- Pull the locator (arrow) to the side and out of the rubber sleeve and remove intake air pipe (2).



- Lift the fuel tank and carefully slide the tank slightly to the rear.



7



▶ Removing fuel-pump unit

- Remove union nut (1) with pin wrench (16 1 021).

ATTENTION

Removal of the fuel-pump unit not in compliance with correct procedure (e.g. prying out with screwdriver)

Leak due to damage to the sealing lip of the flange

- Pull to remove the fuel-pump unit.

- Slightly pull out fuel-pump unit (2).
- Disconnect plug (3).
- Remove fuel-pump unit (2) with sealing ring (4).



– with version of September 2010^{CST}

- Remove union nut (1) with pin wrench (16 1 021).

ATTENTION

Removal of the fuel-pump unit not in compliance with correct procedure (e.g. prying out with screwdriver)

Leak due to damage to the sealing lip of the flange

- Pull to remove the fuel-pump unit.

- Remove fuel-pump unit (2) with sealing ring (3).◇

8

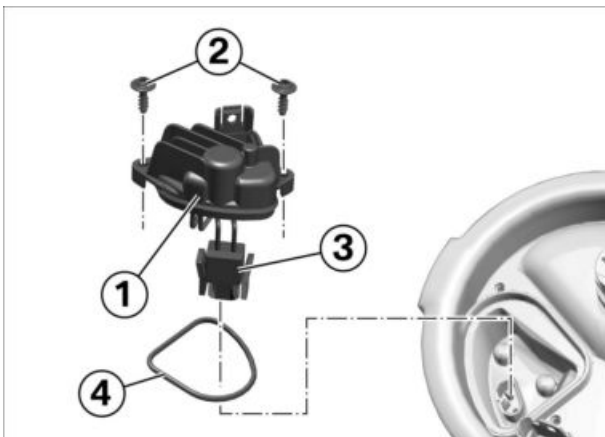

► **Removing fuel-pump electronics**

- Remove screws (2).
- Slightly lift electronics module (1) and disconnect plug (3).
- Remove electronics module with gasket (4).

9

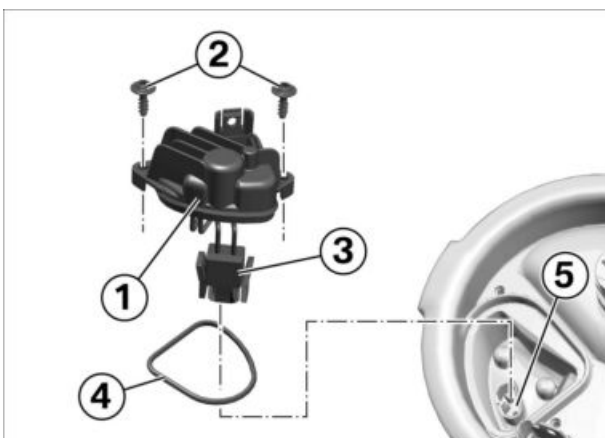

► **Installing fuel-pump electronics**

Check

- Check the electrical contacts of plug (3) and its socket (5).

Result

Significant signs of corrosion on the contacts.

Measure

- Replace the fuel-pump electronics or the fuel-pump unit.
- Remove water or moisture, if present.
- Check gasket (4) for damage. Replace the gasket if it is swollen or damaged.
- Lubricate gasket (4) **thinly**.

 Care products	
Rubber care product	83 12 0 397 018

- Position gasket (4) on electronics module (1).
- Connect plug (3).

- Press electronics module (1) with gasket (4) all the way into the pump flange, taking care to keep the module square in its recess in the process.
- Engage screws (2) and tighten uniformly.

10

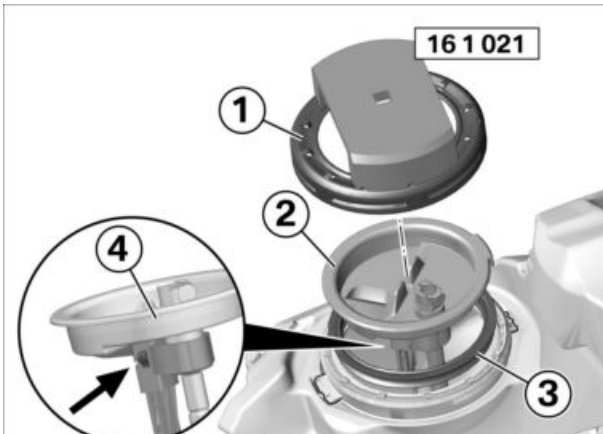

► Removing sucking jet pump unit

- Remove union nut (1) with pin wrench (16 1 021).

ATTENTION

Removal of the fuel-pump unit not in compliance with correct procedure (e.g. prying out with screwdriver)
Leak due to damage to the sealing lip of the flange

- Pull to remove the fuel-pump unit.

- Slightly pull out sucking jet pump unit (2).
- Open the retainer (arrow), remove flange (4) with sealing ring (3).

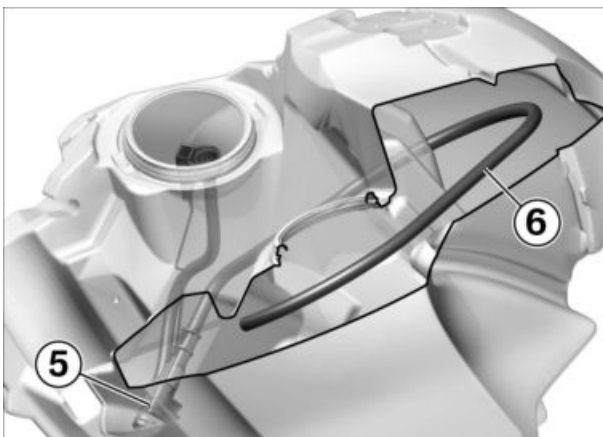

- Remove sucking jet pump (5) complete with delivery hose (6).

11

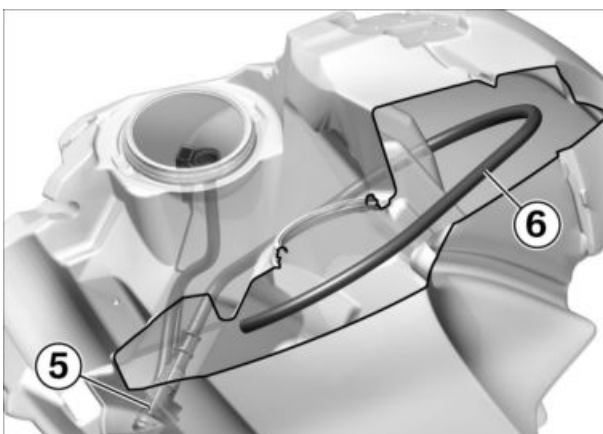

► Installing sucking jet pump unit

- Install sucking jet pump (5) with delivery hose (6), making sure that the routing is correct.

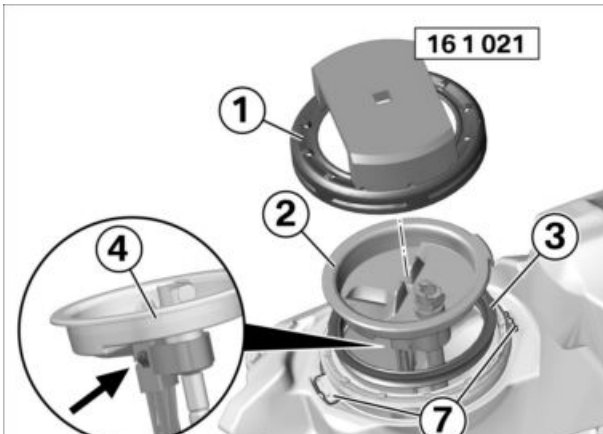

- Check the sealing face of flange **(4)** for damage, paying particular attention to the sealing lip. Always replace the flange if the sealing face shows signs of damage.
- Check sealing ring **(3)** for damage; replace if necessary.
- Seat sealing ring **(3)** in the fuel tank and lubricate the ring's contact face with the fuel-pump unit.

Installation tool	
Tyre-fitting paste	81 22 0 433 046

- Position the sucking jet pump on flange **(4)**.
 - » The locking device **(arrow)** engages.
- Carefully introduce pump unit **(2)** into the fuel tank, making sure that sealing ring **(3)** is correctly seated (visible round the entire circumference).
- Install union nut **(1)** with pin wrench (16 1 021). Make sure that the retaining ring does not turn during this process, and that its lugs **(7)** remain in position in the corresponding recesses.

Tightening torques	
Fuel pump to fuel tank	
Union nut	35 Nm

12



► Installing fuel-pump unit

- Check the sealing face of fuel-pump unit **(2)** for damage, paying particular attention to the sealing lip. Always replace the flange if the sealing face shows signs of damage.
- Check sealing ring **(4)** for damage; replace if necessary.
- Seat sealing ring **(4)** in the fuel tank and lubricate the ring's contact face with the fuel-pump unit.

Installation tool	
Tyre-fitting paste	81 22 0 433 046

- Connect plug **(3)**.
- Carefully introduce fuel-pump unit **(2)** into the fuel tank, making sure that sealing ring **(4)** is correctly seated (visible round the entire circumference).
- Install union nut **(1)** with pin wrench (16 1 021). Make sure that the retaining ring does not turn during this process, and that its lugs **(arrows)** remain in position in the corresponding recesses.

Tightening torques	
Fuel pump to fuel tank	
Union nut	35 Nm



– with version of September 2010^{CST}

- Check the sealing face of fuel-pump unit **(2)** for damage, paying particular attention to the sealing lip. Always replace the flange if the sealing face shows signs of damage.
- Check sealing ring **(3)** for damage; replace if necessary.
- Seat sealing ring **(3)** in the fuel tank and lubricate the ring's contact face with the fuel-pump unit.

 Installation tool	
Tyre-fitting paste	81 22 0 433 046

- Carefully introduce fuel-pump unit **(2)** into the fuel tank, making sure that sealing ring **(3)** is correctly seated (visible round the entire circumference).
- Install union nut **(1)** with pin wrench (16 1 021). Make sure that the retaining ring does not turn during this process, and that its lugs **(arrows)** remain in position in the corresponding recesses.

 Tightening torques		
Fuel pump to fuel tank		
Union nut	35 Nm	

13

► Securing fuel tank

- Push the fuel tank from behind into the rubber mounts on the frame. Make sure that no lines, hoses or Bowden cables are trapped.
- Lift the fuel tank.

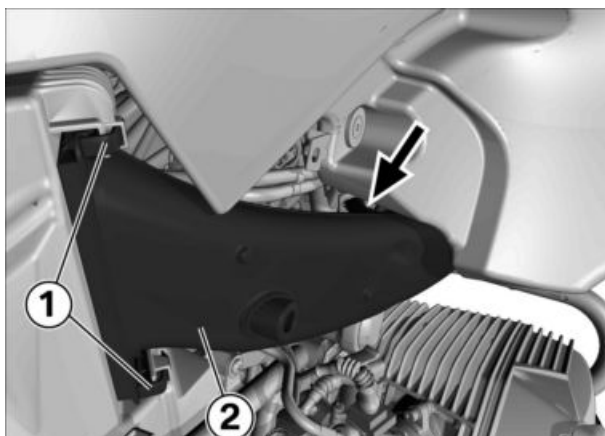

▷ Installing intake air pipe

- Insert intake snorkel **(2)** and slide in retaining brackets **(1)** until they engage with a click.
- Press the detent pin **(arrow)** completely into the rubber grommet.

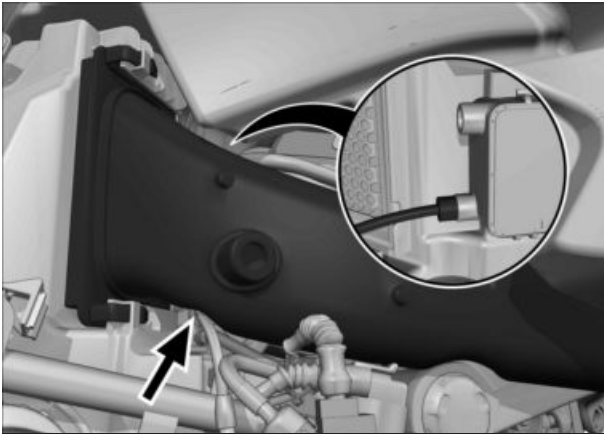

- Make sure the throttle-valve cable is seated in the guide of the intake snorkel (**arrow**) and was not pulled out of the distributor (**magnifying glass**).

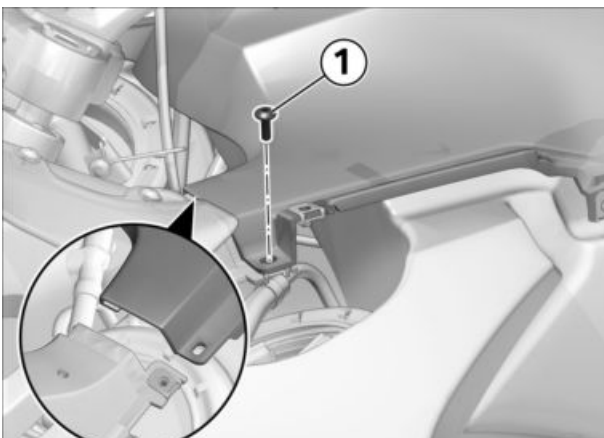

- Work the trim panel into position at the top wheel cover (**detail**).
- Install screws (**1**) on left and right.

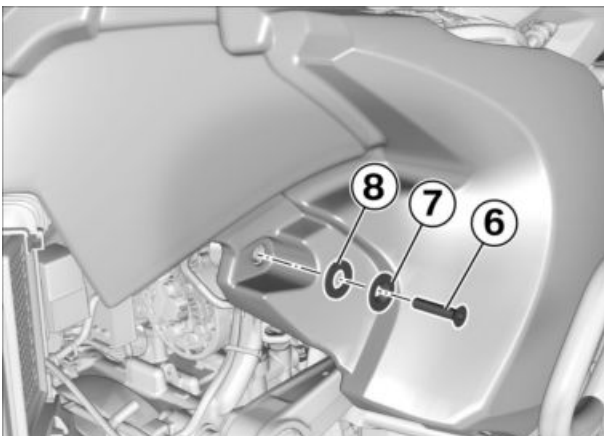

- Install screws (**6**) with washers (**7**) and rubber washers (**8**) on the left and right.

 Tightening torques		
Fuel tank with bracket to front frame		
M8 x 40	19 Nm	

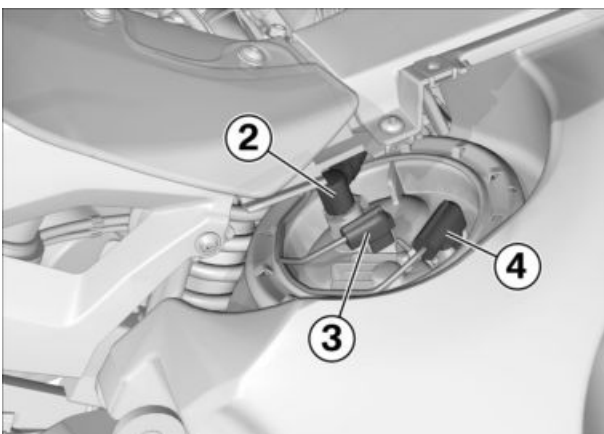



- Check O-rings on quick-release coupling (**2**) for damage and replace as needed.
- Lubricate the quick-action couplings to facilitate assembly.

 Lubricant	
Molykote 111	11 00 7 660 832

ATTENTION
Application of force to close locked quick-action couplings
 Leak due to damaged O-rings

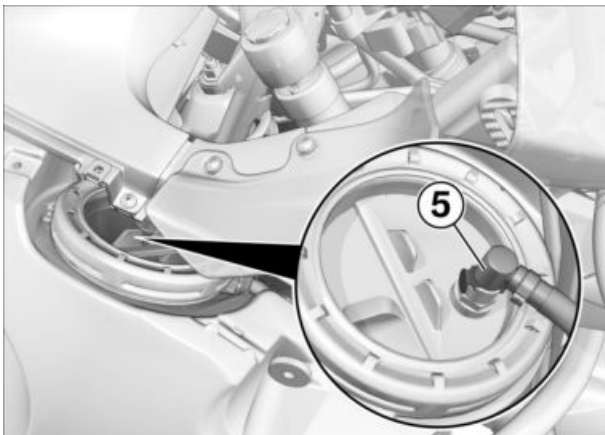
- Close the quick-action coupling of the fuel line only with the latch open/pressed.
- Open the locks on the female coupling of the pressure line **(2)** and push connector into the female coupling with light pressure.
 - » The female coupling engages with an audible click.
- Connect connector of electric fuel pump **(3)** and fuel level sensor **(4)**.
- Check O-rings on quick-release coupling **(5)** for damage and replace as needed.
- Lubricate the quick-action couplings to facilitate assembly.



 Lubricant	
Molykote 111	11 00 7 660 832

ATTENTION

Application of force to close locked quick-action couplings

Leak due to damaged O-rings

- Close the quick-action coupling of the fuel line only with the latch open/pressed.
- Open the locks on the female coupling of the pressure line **(5)** and push connector into the female coupling with light pressure.
 - » The female coupling engages with an audible click.

14

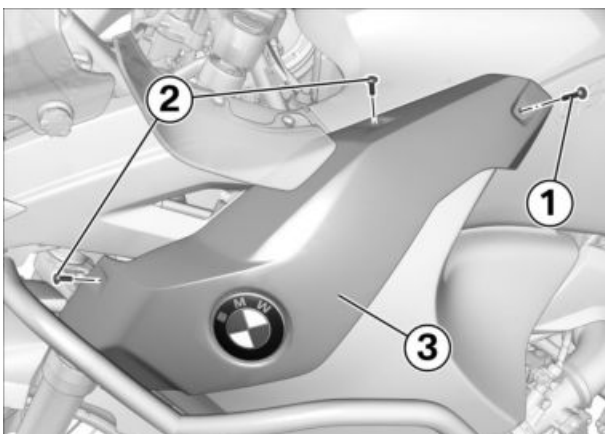

► **Installing side panels**

- Hold side panels **(3)** in position.
- Install long screws **(1)**.
- Install short screws **(2)**.

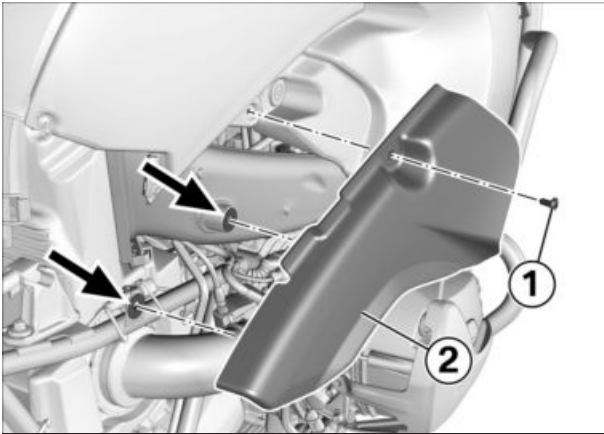
15**► Installing right side cover**

- Hold side cover **(2)** in position and push the snap-fit studs into the holders **(arrows)**.
- Install screw **(1)**.

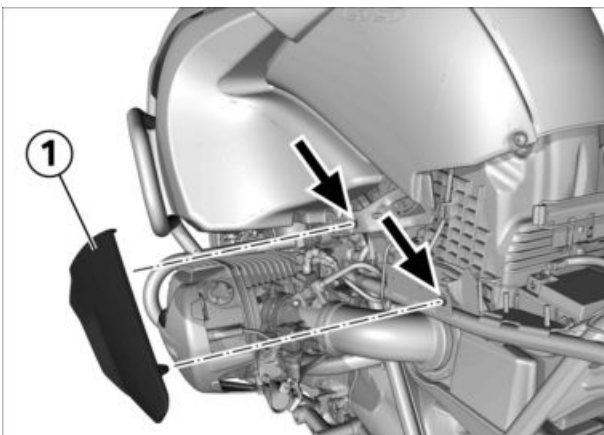
**16****► Installing left side cover**

- Hold side cover **(1)** in position and push the snap-fit studs into the holders **(arrows)**.

**17****► Connecting BMW Motorrad diagnostic system to vehicle****NOTICE**

See the information about the BMW Motorrad diagnostic system for all further instructions.

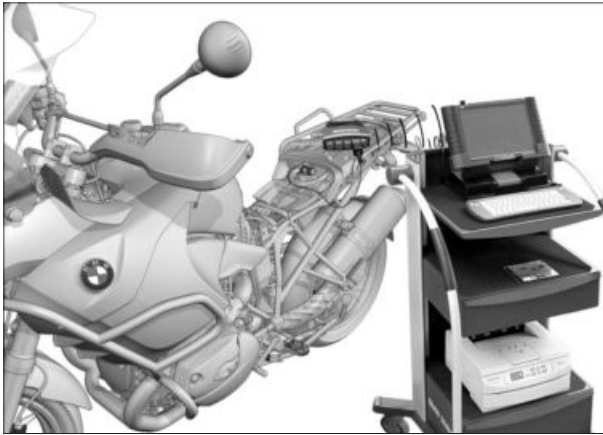

- Connect the BMW Motorrad battery charger.

Workshop equipment



Order No.: 81 74 0 421 092

BMW Motorrad battery charger (version for Europe without GB)

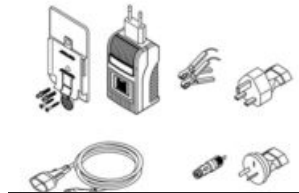

Order No.: 81 74 0 421 094

BMW Motorrad battery charger (GB/AUS/NZL version)



Order No.: 81 74 0 421 097

BMW Motorrad battery charger (Japan version)



Order No.: 81 74 0 421 098

BMW Motorrad battery charger (USA/CAN version)

- **Begin by switching on the BMW Motorrad diagnostic system** and wait for it to power up.
- » The "Start Diagnosis" screen appears.
- From this point on, follow the instructions issued by the BMW Motorrad diagnostic system.

► **Reading fault memory with BMW Motorrad diagnostic system and resetting adaptation values**

NOTICE

When working with the BMW Motorrad diagnostic system, always follow the instructions it issues.

- Read out the fault memory.
- Perform all requisite repair work.
- Reset the adaptation values.
- Adaptation group in ISTA process "Read/reset adaptation values":

» Mixture preparation



19

► Disconnecting BMW Motorrad diagnostic system from motorcycle

- Terminate the diagnosis session correctly and switch off the ignition.
- Disconnect KOMET from the motorcycle and screw the cap onto the diagnosis plug.
- Disconnect the BMW Motorrad battery charger from the motorcycle.



20

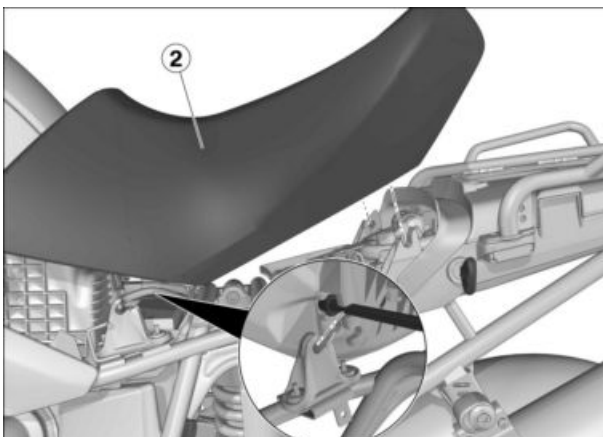

► Installing front and rear seats

- Introduce front seat **(2)** into the front catch.
- Firmly press down on front seat **(2)** at the rear.
 - » The seat engages with an audible click.

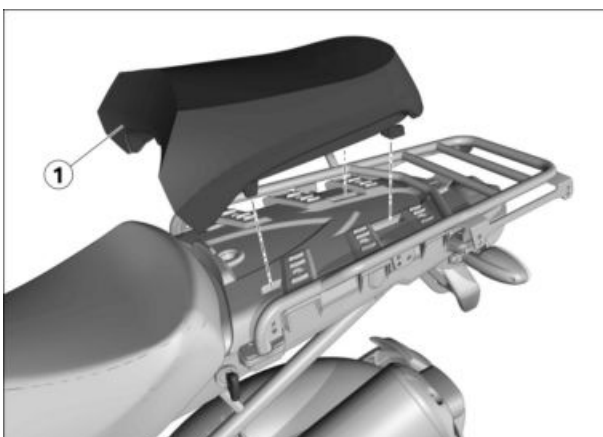

- Hold rear seat **(1)** in position and press it down firmly at the front.
 - » The seat engages with an audible click.



21

► Filling fuel tank

WARNING

Fuel is highly flammable and hazardous to health

Risk of fire, risk of damage to health

- Comply with the safety regulations.

- Fill the fuel tank with fuel.

NOTICE

The sucking jet pump operates only when the electric fuel pump is delivering fuel. This means that the left pocket of the tank must contain fuel. Consequently, be sure to pour fuel into the left pocket when filling the fuel tank, or pour in at least the minimum required quantity (fuel tank empty beforehand).

 Technical data			
Minimum quantity, fuel tank empty		8 l	

22

► Final check of work performed

- Check the following:
 - The work as performed achieved the intended purpose.
 - All reservoirs and containers have been filled and all fluids and lubricants are at their correct levels.
 - All threaded fasteners released beforehand have been correctly retightened.
 - The fuel system is free of leaks.
 - The lights and signalling equipment are fully operational and the vehicle is roadworthy.
 - The brake pads of the front and rear brakes are bedded against the brake discs.

▷ Function test, engine start suppression

NOTICE

Engine start is not enabled if you pull the clutch with a gear engaged before switching on the ignition.

- with anti-theft alarm (DWA)^{OE} (0603)
- Deactivate the anti-theft alarm system.◇

Check

- Set kill switch to centred position.
- Select neutral.
 - » Neutral indicator light "N" lights up.
- Select a gear.
 - » Neutral indicator light "N" goes out.
- Press the starter button.
 - » Starter does **not** operate.
- Extend the side stand.
- Pull the clutch lever.
- Press the starter button.

- » Starter does **not** operate.
- Retract the side stand.
- Press the starter button without releasing the clutch lever.
- » Starter operates.

Result

Not all test steps completed successfully.

Measure

- Check functional check of engine start suppression and functional check of emergency and safety stop of the engine with BMW Motorrad diagnosis system.

