

# FOREST RIVER RECALL 21V-059

## SAFETY CHAIN REPLACEMENT

### Preparation

**THIS REPLACEMENT SHOULD ONLY BE COMPLETED BY AN AUTHORIZED SERVICE TECHNICIAN.**

#### **⚠ WARNING**

Remove all flammable material from the area to be welded. Any remaining flammable material that cannot be removed must be protected. Proper fire protection and control measures should be kept on hand.

#### **⚠ WARNING**

Lift travel trailer by the frame and never the axle or suspension. Do not go under the travel trailer unless it is properly supported by jack stands. Unsupported travel trailers can fall and may result in death, serious injury or property damage.

**NOTE:** In this document, dashed red lines indicate using a die grinder to remove components and solid red lines indicate using a welder to add components per instructions and image references.

### Tools Required

- Die grinder and cut wheel attachments
- Welder
- Welding PPE (helmet, gloves, sleeves, etc.)
- Jack stands
- Black spray paint (If necessary)

### Hardware Required

- Safety chains
- Chain elbow

**NOTE:** Refer to the cover page of these remedy instructions for specific part numbers.

### Procedure

1. Use the die grinder with the cutting wheel attachment to remove the existing chain elbow from the underside of the A-frame coupler (Fig. 1).
2. The existing safety chains can be set aside with the chain elbow.

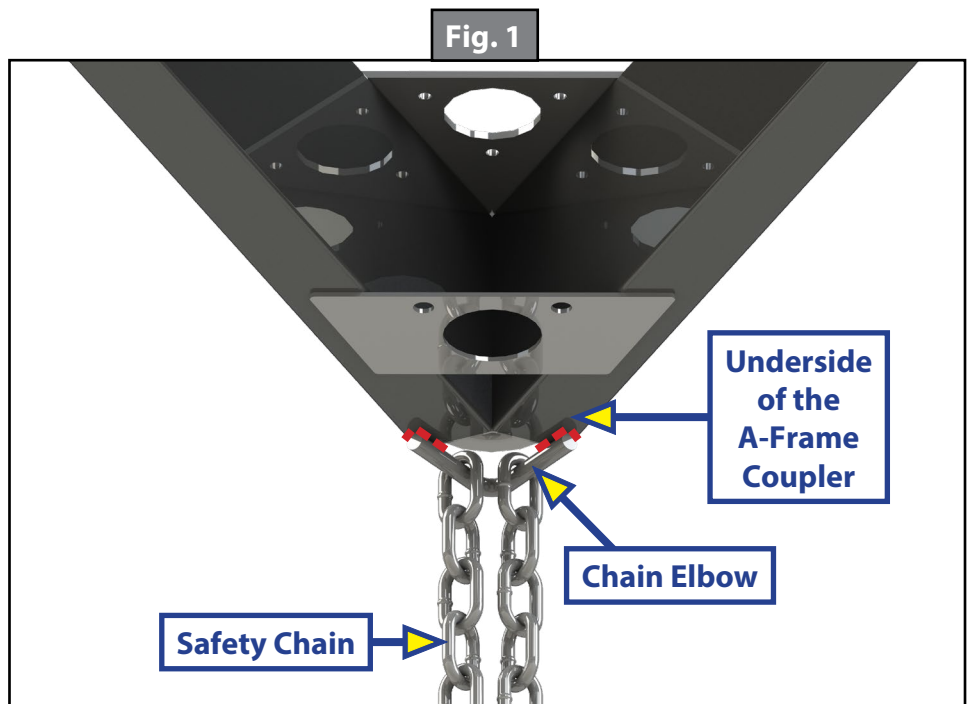

# FOREST RIVER RECALL 21V-059 SAFETY CHAIN REPLACEMENT

3. Use the die grinder and grinding wheel attachment to grind the cut areas smooth (Fig. 2).
4. Feed the last link of each of the new safety chains onto the new chain elbow (Fig. 3).
5. Center the chain elbow and safety chain assembly under the A-frame coupler so that the ends of the chain elbow are touching the ends of the two A-frame tubes. The elbow should be pointing away from the travel trailer.

**NOTE:** Ensure that the new safety chains are not pinched between the chain elbow and the coupler. The safety chains **MUST** be able to move freely.

6. Weld each end of the chain elbow to the A-frame tubes completely (Figs. 4 and 5).
7. Test the movement ability of the safety chains to make sure they are able to move freely.
8. Spray paint any visible areas of the repair with black spray paint.

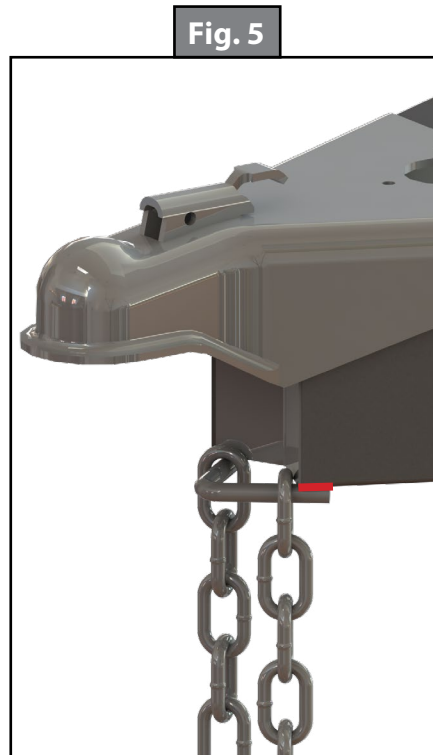
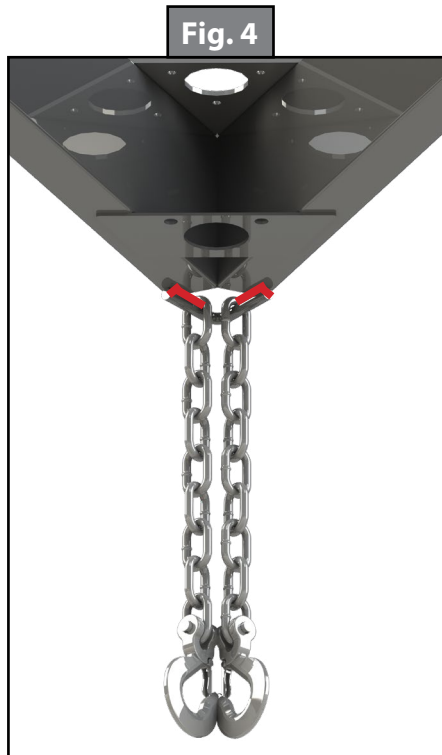
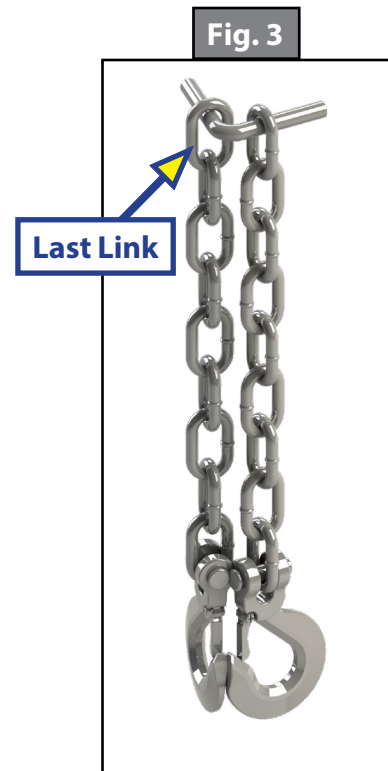
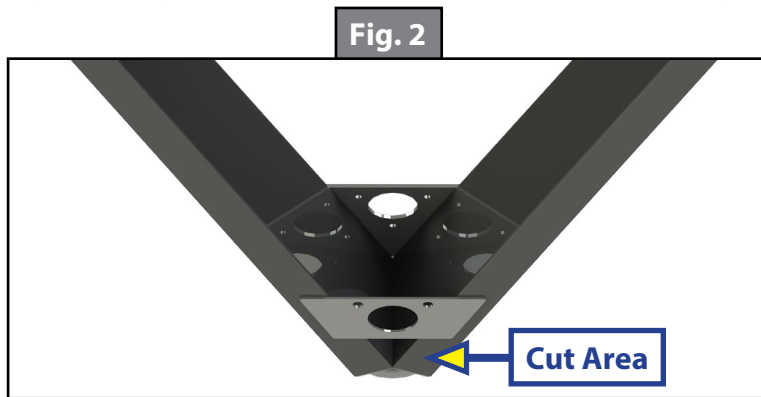

As a supplier of components to the RV industry, safety, education and customer satisfaction are our primary concerns. Should you have any questions, please do not hesitate to contact us at (574) 537-8900 or by email at [customerservice@lci1.com](mailto:customerservice@lci1.com). Self-help tips, technical documents, product videos and a training class schedule are available at [lci1.com](http://lci1.com) or by downloading the MyLCI app.