



Incorrect Leaf Spring Hanger

Bulletin Type:	Safety Recall	Publication Date:	March 29, 2021
Bulletin #(s):	21V-049 US Units 2021-086 Canadian	Make:	Jayco FW
Job Code:	9901563	Models:	Eagle 355MBQS (WA) 321RSTS (WD)
Flat Rate:	4.0 Hours	Model Year:	2021

Incident:	Incorrect spring hanger installed reducing tire clearance.
Affected Units:	2021 Eagle FW - M1WA0171-0230 & M1WD0117-0206
Parts Kits Numbers and Contents:	#21V-049A for the WA Model #21V-049B for the WD Model
	21V-049A – WA 2- HANGER, SPR 3.00X2.45X4.75X 4.75 2- HANGER, Support 3.31X3.31X0.19 2- NUT, Lock Flange .44-20 for shackle bolt 2- BOLT, Hanger Grease .56X2.90 Shoulder .44-20 Thread 21V-049B - WD 2- HANGER, SPR 2.35X5.55X5.55 4GA STL 2- HANGER, Support 3.31X3.31X0.19 2- NUT, Lock Flange .44-20 for shackle bolt 2- BOLT, Hanger Grease .56X2.90 Shoulder .44-20 Thread
Misc. Tools & Supplies:	Jacks, lug wrench, adjustable torque wrench, die grinder, steel welder, socket set and socket wrench
Parts Return Information:	NA

INSTRUCTIONS

1. Position the unit on level ground. The unit must be in a level condition.

NOTE: The unit can be in an “as loaded” state, however not to exceed 3500 pounds for any one tire.

2. Retract ALL stabilizer jacks.
3. Support the frame on jack stands as close to the rear wheel as possible providing a safe and supported platform for the unit to work on. Support the unit on the pin box using a suitable stand or a forklift (Fig.1).
4. Remove the tires and stow for later installation.

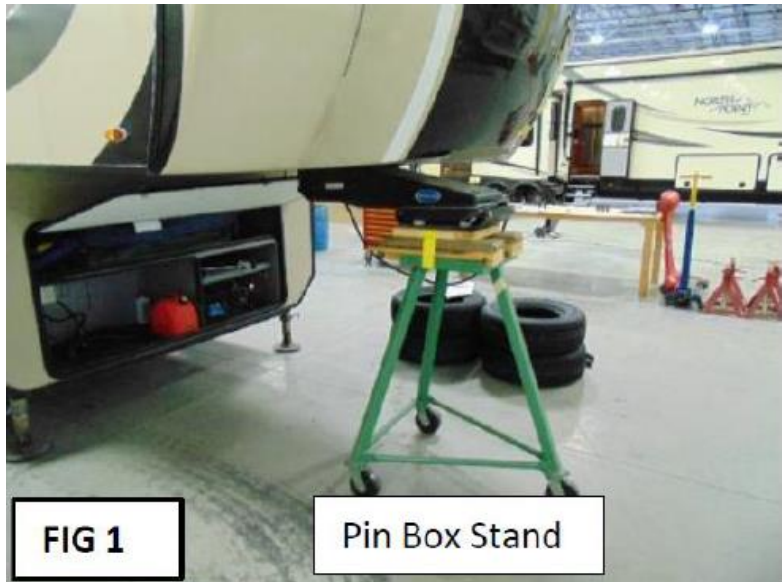

5. Using floor jacks lift the frame slightly and then place properly rated jack stands under the axles (Fig. 2). Position jacks so there is access to drive the shackle bolts out with a hammer.
6. Place suitable blocks under the axle tube near the repair area.

NOTE: The block acts as a support for the weight of the axle only, allowing service of the suspension system components. Multiple axle trailers MUST have the weight of each axle properly supported before disassembly of any suspension system components.

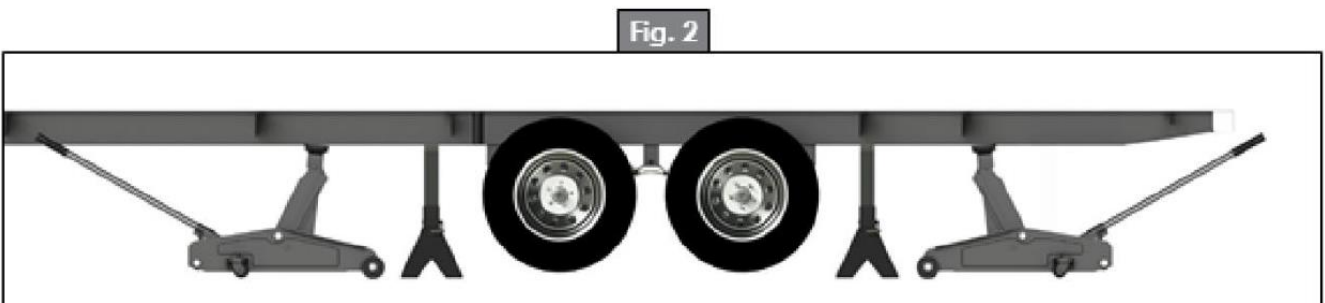

7. Remove the nut and bolt assembly from the center spring hanger. This will allow the CRE equalizer to drop from the spring hanger. Perform this step on both side of the unit.
8. Cut the welds securing the center spring hanger to allow removal. Use care to avoid damage to the surface areas. Once the hanger is out of the way, grind the area smooth in preparation for re-welding the new spring hanger to the frame.

9. Select the correct replacement spring hanger from the following parts list.

FIG. 3

M1WA

Remove the 3 1/4" center hanger and hanger support and install a 4 1/4" center hanger and hanger support as noted above on the door side and off door side of the unit.

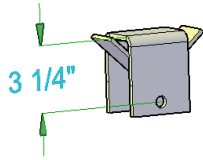

Remove

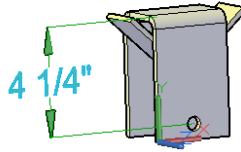

Install

M1WD

Remove the 4 1/4" center hanger and hanger support and install a 5" center hanger and hanger support as noted above on the door side and off door side of the unit.

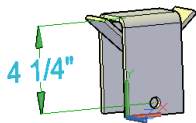

Remove

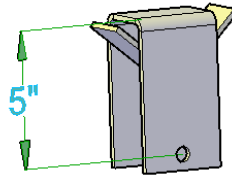

Install

10. Center the new spring hanger between the front spring hanger and the rear spring hangers. Clamp into place. **The spring hanger requires a full weld to the frame by a qualified welder as shown below.**

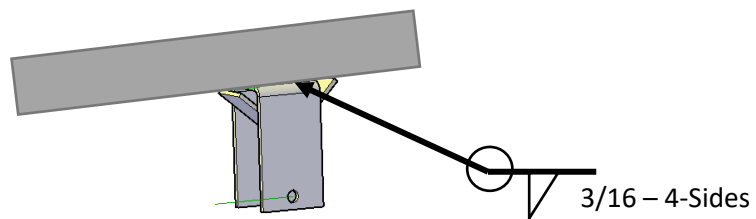

11. Clean the weld area and paint black to avoid corrosion.

12. Reinstall the CRE equalizer using new bolts and lock nuts provided. Torque the nut to 35 to 45 ft.-lbs.
13. Grease the wet bolts prior to continuing.
14. Install tires and wheel previously removed, and torque to 120 ft.-lbs. in a proper star pattern shown in Figure 9, on the next page.
15. Remove jack stands.
16. Drive the unit through the lot doing s-turns and re-torque the wheel nuts to 120 ft.-lbs., following the same star pattern shown in figure 9.

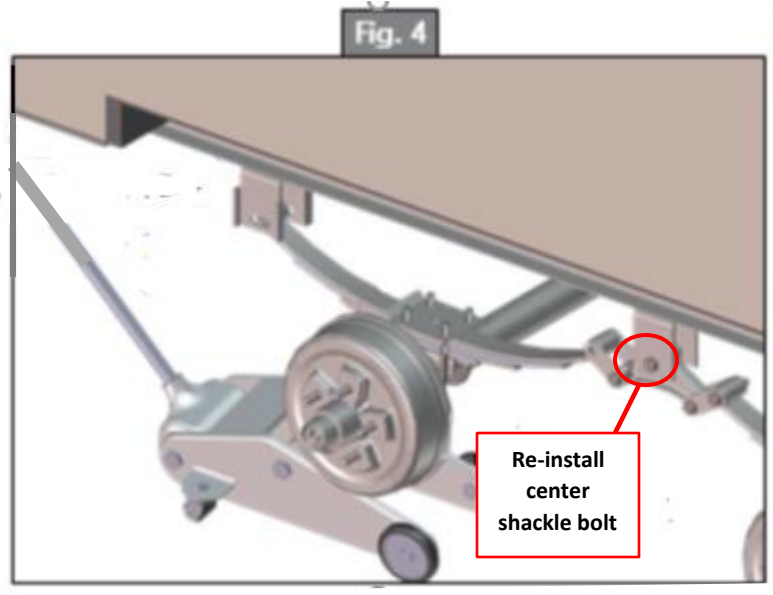

Jayco's sole obligation under our limited warranty is to repair or replace defective materials and/or workmanship deemed our responsibility as determined by Jayco in our sole discretion. Jayco reserves the right to use new and/or remanufactured parts or materials of similar quality to complete any work, and to make parts and/or design changes as appropriate without notice to anyone. Jayco designs and/or materials changes are done without obligation to incorporate such changes in previously manufactured product. Jayco makes every reasonable effort to ensure field remedies will not adversely affect performance and/or safety of the unit. This field remedy is not intended to extend to future performance of this RV, or any of its materials, components or parts beyond the standard warranty period. The RV owner's obligation to notify Jayco, or one of its independent, authorized dealers, of a claimed defect does not modify any obligation placed on the RV owner to contact Jayco directly when attempting to pursue remedies under state or federal law. Jan. 2019.

903 South Main Street • P.O. Box 460 • Middlebury, IN 46540



LEAF SPRING REPLACEMENT ON AN EXISTING AXLE BEAM

TI-345

AXLES AND SUSPENSION

- D. If installing new or previously removed wet bolts, apply new grease. Use NLGI code GC-LB.
- E. Reconnect any disconnected electrical lines and/or hydraulic hoses (step 5).

NOTE: If reconnecting hydraulic hoses, make sure all hydraulic lines are purged of air.

19. Reinstall previously removed tires, wheels and lug nuts (steps 3 and 4) onto the axle (Fig. 3).
 - A. Start all wheel lug nuts by hand to prevent cross-threading.
 - B. Continue to hand-tighten wheel lug nuts in the sequential pattern shown in figure 9.
 - C. After wheel lug nuts are fully hand-tightened, torque nuts in stages and in the sequential pattern shown in figure 9.

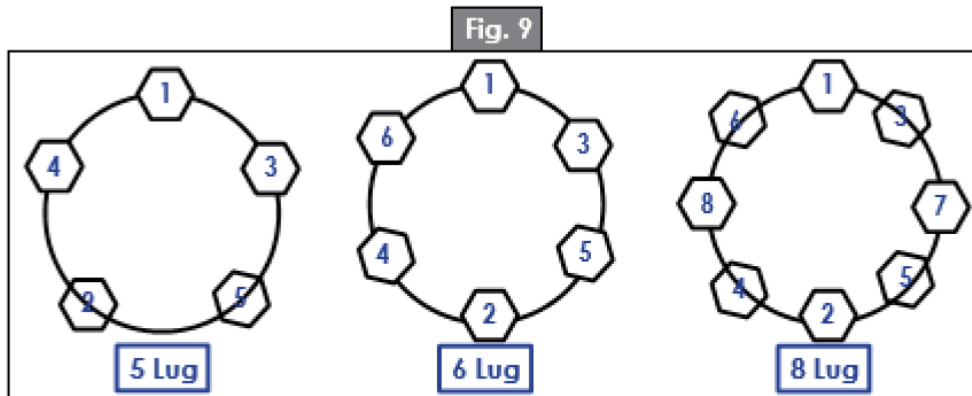

- D. Torque wheel lug nuts to the torque values listed in the Wheel Torque Requirement Chart.

Wheel Torque Requirement Chart				
Wheel Size	Stud Size	Torque Sequence		
		1st Stage	2nd Stage	3rd Stage
14"	1/2"	20-25 ft-lbs	50-60 ft-lbs	90-120 ft-lbs
15"	1/2"	20-25 ft-lbs	50-60 ft-lbs	90-120 ft-lbs
16"	1/2"	20-25 ft-lbs	50-60 ft-lbs	90-120 ft-lbs
16.5" x 6.75"	1/2"	20-25 ft-lbs	50-60 ft-lbs	90-120 ft-lbs
16"	9/16"	20-25 ft-lbs	60-70 ft-lbs	120-130 ft-lbs
16.5" x 6.75"	9/16"	20-25 ft-lbs	60-70 ft-lbs	120-130 ft-lbs
16" Dual and 17.5" Cone Nut	5/8"	50-60 ft-lbs	100-120 ft-lbs	190-210 ft-lbs
16" Dual and 17.5" Flange Nut	5/8"	50-60 ft-lbs	150-200 ft-lbs	275-325 ft-lbs
14.5" Demount	1/2"	Tighten sequentially to 85-95 ft-lbs		