



## IMPORTANT SAFETY RECALL

This notice applies to your vehicle [VIN]  
NHTSA Recall 21V-863

February 2, 2022

Dear Penske Leasing:

This notice is sent to you in accordance with the National Traffic and Motor Vehicle Safety Act. Cottrell, Inc. (Cottrell) is recalling certain 2019-2022 2-Car Carrier vehicles. Four side-rear reflex reflectors are missing. As such, these vehicles fail to comply with the requirements of Federal Motor Vehicle Safety Standard number 108, (FMVSS) "Lamp, Reflective Devices, and Associated Equipment. Missing reflex reflectors reduce the vehicle's visibility to other drivers, increasing the risk of a crash.

Please find enclosed an Installation Guide with detailed instructions on how to install four (4) reflex reflectors on your Cottrell 2-Car Hauler. The four (4) reflex reflectors (2 Red and 2 Amber) are to be installed as follows: one (1) Amber reflector on each side of the unit near the midpoint between the front and rear reflectors (2 total Amber reflectors), and two (2) Red Reflectors on the rear cross member, all as shown in the enclosed Installation Guide. All parts needed to properly install the reflex reflectors are being provided to you free of charge.

Once you have completed the installation above, please email Cottrell to report the installation is complete on the particular VIN number at issue, at:

[Warranty@Cottrelltrailers.com](mailto:Warranty@Cottrelltrailers.com)

This installation can be performed at the Cottrell Service Center in Gainesville, Georgia, at any Authorized Cottrell Warranty Repair Facility, or at a repair facility of your choice. You can access a list of Authorized Cottrell Warranty Repair Facilities at [www.cottrelltrailers.com](http://www.cottrelltrailers.com) under "Find a Dealer."

If you no longer own your 2-Car Carrier vehicles, please contact Cottrell at 1-800-827-0132 Ext 103 or email us at [warranty@Cottrelltrailers.com](mailto:warranty@Cottrelltrailers.com).

If you are the lessor of these vehicles, please forward a copy of this notice to the lessee within ten days to comply with federal regulations.

Cottrell will reimburse labor for this installation at the maximum rate of one-half (.5) of an hour. Requests for reimbursement can be submitted with receipts to the above email address or handled directly through the repair facility using normal warranty procedures.

Please perform this installation as soon as possible following the instructions provided. Should you have any questions concerning this installation, please contact warranty at the email address or phone number indicated below.



If after having attempted to take advantage of this recall you believe you have not been able to have your 2-Car Carrier vehicle remedied without charge and within a reasonable amount of time, you may submit a complaint to the Administrator, National Highway Traffic Safety Administration, 1200 New Jersey Ave., S.E., Washington, D.C., 20590; or call 1-888-327-4236 (TTY: 1-800-424-9153); or go to <https://www.nhtsa.gov>.

Sincerely,

*Austin Peal*

Austin Peal / Warranty Coordinator  
Warranty@Cottrelltrailers.com  
1-800-827-0132 Ext. 103

2125 Candler Road, Gainesville, Georgia 30507

[www.cottrelltrailers.com](http://www.cottrelltrailers.com); 1-800-827-0132



February 2, 2022

**Penske Leasing**

The following VIN's are involved in campaign. **Total Units Remaining 2**

**Cottrell Order#**

**Tractor VIN**

G001575501

54DK6S164LS [REDACTED]

G001595701

54DK6S165MS [REDACTED]

# REFLECTOR INSTALLATION GUIDE

2-CAR DELIVERY UNITS MANUFACTURED BY COTTRELL, INC.

- 1 . CLEAN MOUNTING SURFACE OF ANY GREASE OR DIRT.
- 2 . REMOVE PROTECTIVE PAPER BACKING AND PLACE REFLECTOR (98003R/Y) IN A HORIZONTAL ORIENTATION AS SHOWN.
- 3 . PRESS FIRMLY TO ENSURE ADHESION.

KIT 169610 INCLUDES:  
2 X REFLECTOR 98003R  
2 X REFLECTOR 98003Y  
1 X ALCOHOL WIPE

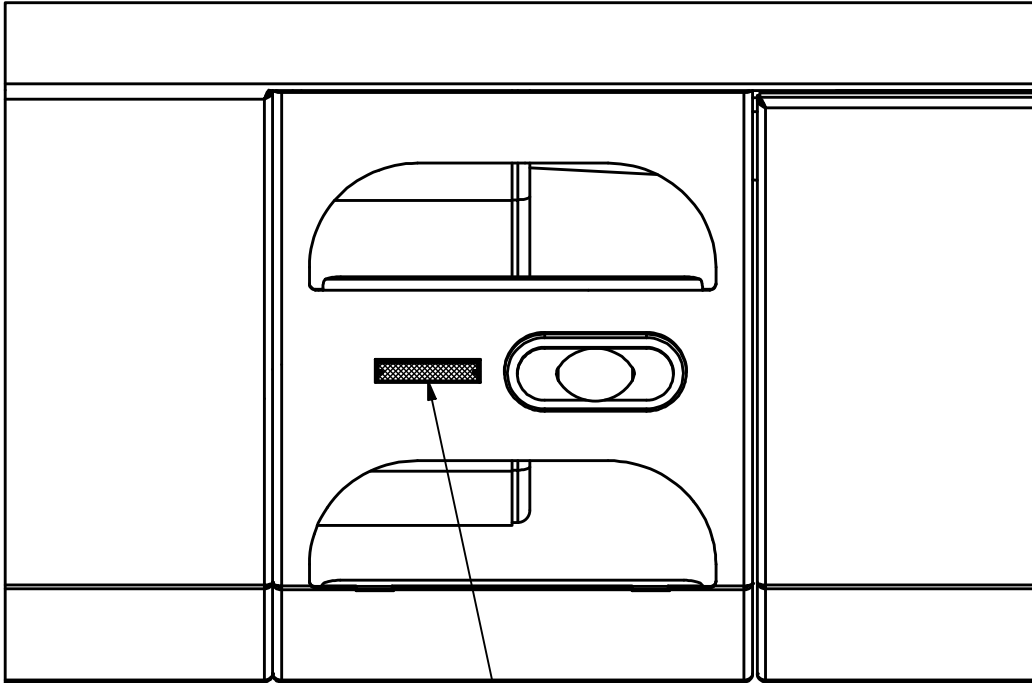

→  
**REAR OF UNIT**

— ALIGN CENTER OF **AMBER** REFLECTOR (98003Y) WITH CENTER OF MID-TURN LIGHT AND PLACE DIRECTLY ADJACENT TO LIGHT ON EACH SIDE.

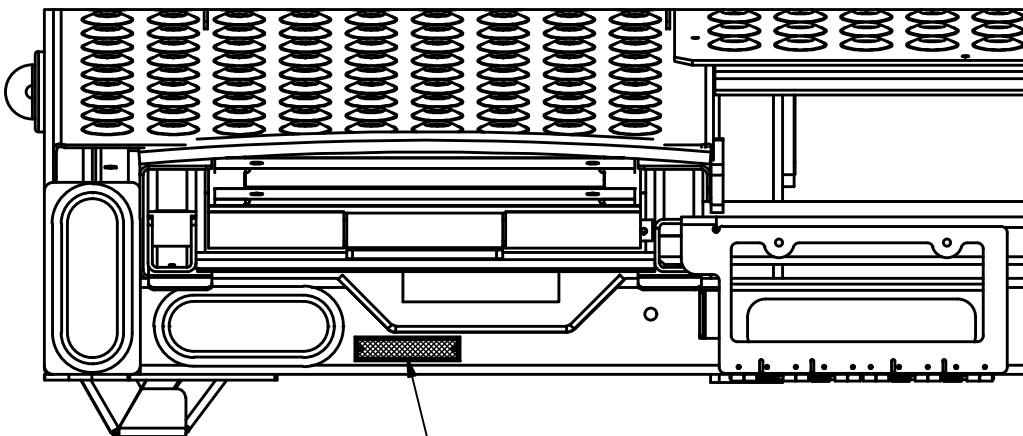

**REAR VIEW OF UNIT**

— CENTER **RED** REFLECTOR (98003R) VERTICALLY ON THE SURFACE IMMEDIATELY ADJACENT TO STOP/TAIL/TURN LIGHTS ON EACH SIDE.