



Customer Outreach
PO Box 8338
Saint Joseph, MO 64508

product.safety@altec.com
altec.com/altec-connect/

Phone 1-877-GO ALTEC

IMPORTANT SAFETY RECALL

This notice applies to your vehicle. Refer to the provided list.

NHTSA Recall Number: 21V736

Transport Canada Number: N/A

Altec Identifier: CSN-3215

April 07, 2025

Dear Altec Owner,

For US owners, this notice is sent to you in accordance with the *National Traffic and Motor Vehicle Safety Act*. For Canadian owners, this notice is sent to you in accordance with the requirements of the *Motor Vehicle Safety Act*. This is to inform you that your vehicle may contain a defect that could affect the safety of a person.

Altec Industries, Inc. has decided that a defect which relates to motor vehicle safety exists in certain AT200A aerial units built on Ford F350 chassis from July 2014 through July 2016. These units could have the potential for cracking to occur in the mounting frame. The cracking can lead to failure of the mounting frame, causing uncontrolled boom movement, **and increasing the risk of death or serious injury.**

Refer to the included notice for the items covered under the Altec Warranty Policy. If you had this repair performed before you received this notice, you may be eligible to receive reimbursement for the cost of obtaining a pre-notification remedy of the problem associated with this recall.

Compare your unit's identifying information with the provided list to verify your unit is affected. You may also contact Altec or view your fleet through Altec Connect to determine if there are any other outstanding notices.

The inspection and repair, consisting of inspecting the mounting frame side plate, can be performed by a qualified person, or you may contact Altec for further assistance. The inspection is expected to take 30 minutes to complete. The repair is expected to take 2 hours to complete. All work will be performed at no charge to the customer when presented for repair.

If you have sold or retired the unit, update the records through Altec Connect. If you have leased this equipment to another person or company, you are required by Federal Law to forward a copy of this notice to the lessee by first class mail within ten (10) days of the receipt of this notice.

For US owners: After contacting Altec, if you are still not able to have the safety condition remedied without charge and within a reasonable time, you may submit a complaint to: Administrator, National Highway Traffic Safety Administration, 1200 New Jersey Avenue SE, Washington, DC 20590 or call toll-free 1-888-327-4236 (TTY: 1-800-424-9153) or go to <http://www.safercar.gov>.

For Canadian Owners: If you are still not able to have the safety condition remedied by your dealer within a reasonable time, please contact Altec.

We regret this inconvenience; however, we are taking this action in the interest of your safety and continued satisfaction with Altec products.

Thank you for your immediate attention on this important matter.

Mounting Frame Inspection

Units Affected: Certain AT200A aerial devices built on Ford F350 chassis from July 2014 to July 2016. Verify your unit is affected by reviewing the attached list or accessing Altec Connect.

Background: Altec has learned that the street side mounting frame side plate could have a crack. The cracking can lead to failure of the mounting frame, causing uncontrolled boom movement, and increasing the risk of death or serious injury.

**WARNING**

Death or serious injury could result from uncontrolled boom movement. Cracks in the mounting frame side plate could cause mounting frame failure and uncontrolled boom movement. Reinforce and repair the mounting frame side plate.

Customer Action: Inspect the street side mounting frame side plate using the Inspection Procedure beginning on page 2 and order and install the Mounting Frame Reinforcement Kit, part number 991832504. Every unit requires the kit installation for completion. The inspection procedure will determine if the unit can remain in service until it is installed and how soon it should be installed.

Complete this inspection or contact Altec to complete this inspection no later than 60 days from receipt of this notice or the next preventive maintenance cycle, whichever comes first. Completing this work will reinforce the mounting frame and prevent cracking in the side plate as well as prevent further damage if cracking has already occurred.

Subsequent damage due to failure to perform the required action(s) in the time period allowed will not be covered by warranty.

Ask your service provider to check for any outstanding notices at your next appointment.

Requirements: The inspection is estimated to take 30 minutes and 1 person to complete. The repair is estimated to take 2 hours and 1 person to complete. All welds must be applied by a welder having the AWS D1.1 3G qualification for uphill progression welding on steel.

Altec Use Only	
Inspection labor	1.0 hr (Service); 0.5 hr (Other)
Repair labor	2.5 hr (Service); 2.0 hr (Other)
Account #	010.0557.43156.000.9513.000
Travel	Not included
NHTSA code	90
Prime fail P/N	970601937
Kit instructions	074900976

Altec Use Only			
Description	Part No.	Qty	Warranty
Mounting frame reinforcement kit	991832504	1	Yes

Completion and Warranty: The inspection and repair are covered under the Altec Warranty Policy and can be performed by Altec, the customer, or the customer's warranty provider. All welds must be applied by a welder having the AWS D1.1 3G qualification for uphill progression welding on steel. An Altec Mobile Service technician can perform this inspection but is not able to perform this repair. Altec will perform the work for free at an Altec facility. If the customer or the customer's warranty provider performs the work, a warranty claim must be submitted to be reimbursed for the cost of the parts and/or labor. Altec will allow up to \$45.00 for the labor to perform the inspection and up to \$180.00 for the labor to perform the repair. Customers are responsible for the travel costs of an Altec Mobile Service technician if the technician performs the work at the owner's location.

Altec Contact Info:

Phone: 1-877-GO ALTEC (1-877-462-5832) — Altec Connect Customer Portal: altec.com/altec-connect/

Inspection Procedure

Required Tools

- Normal mechanic's hand tools
- Flashlight
- Wire brush

Inspection Procedure A

1. Read and understand all steps of the instructions before beginning the procedure. Wear appropriate personal protective equipment (PPE) following your employer's requirements.
2. Position the unit on a level surface, apply the parking brake, and turn off the engine. Remove the key from the ignition, and secure it following your employer's vehicle lockout/tagout procedure. Chock the wheels.
3. Find the mounting frame under the vehicle (refer to Figure 1). Determine the orientation of the mounting frame.
4. Inspect the narrow section at the rear portion of the side plate on the street side of the mounting frame. Use a wire brush to remove any paint and rust from this area.
5. Using a flashlight, inspect the outer surface and the upper and lower rounded corners of the narrow section of the side plate (refer to Figure 1) for the extent of any cracking in the steel plate.
 - No cracking means no visible cracking at all in the plate.
 - Partial cracking means a visible crack anywhere in the narrow section that extends only part way across the width or part way through the thickness of the plate (refer to Figure 2).
 - Full cracking means a visible crack across the full width of the narrow section extending through the full thickness of the plate and causing the complete separation of the material (refer to Figure 3).

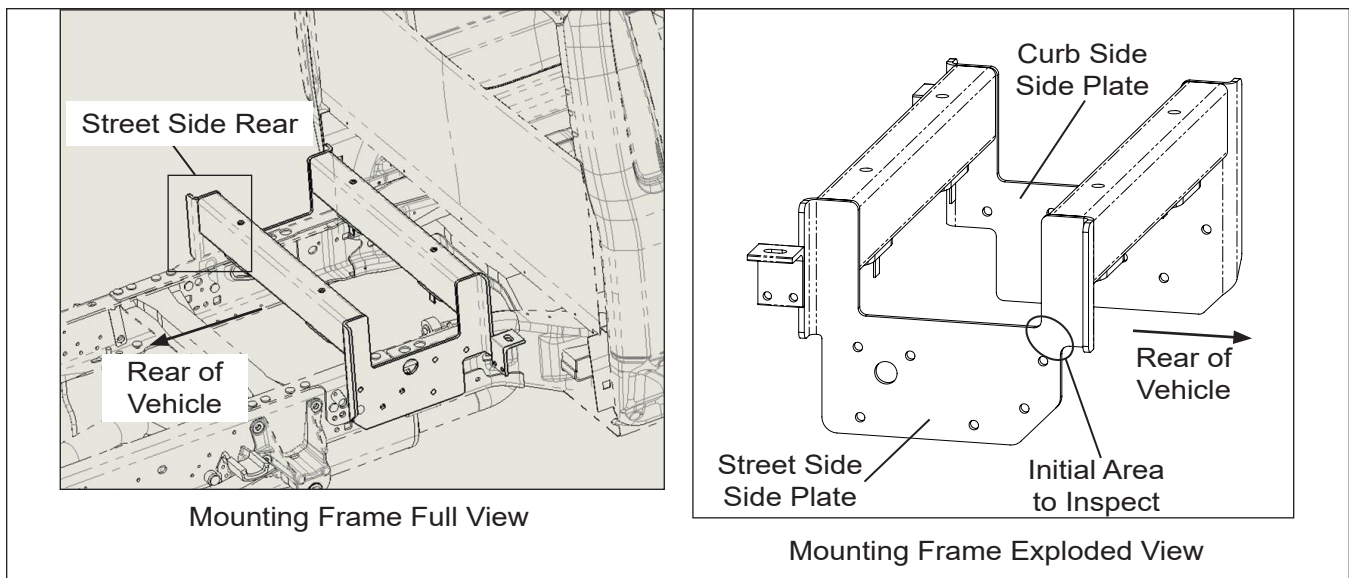

Figure 1 – Mounting Frame Initial Inspection

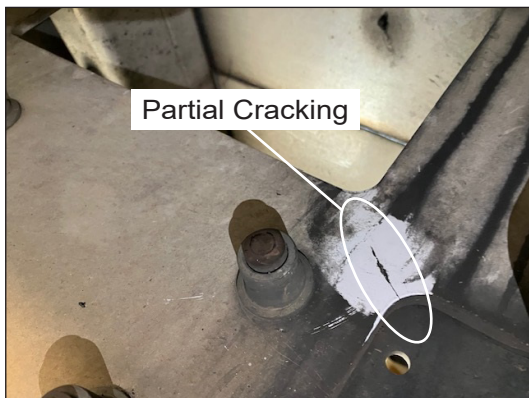

Figure 2 – Partial Cracking Example

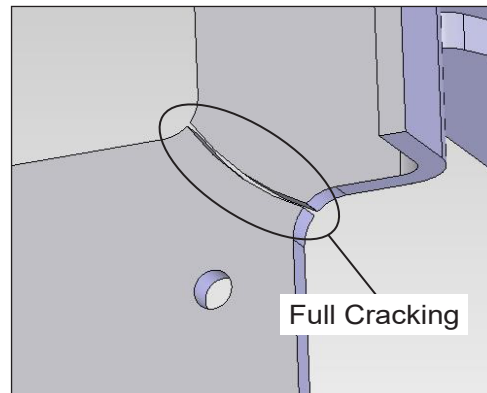

Figure 3 – Full Cracking Example

6. Review the inspection results, and take the specified action based on the initial inspection area.
 - If there is **no cracking**, put the unit back into service. Order the Mounting Frame Reinforcement Kit, part number 991832504, and install it within one year of the inspection. Do not perform Inspection Procedures B. Inspect this area regularly as outlined in the Preventive Maintenance and Inspection Checklist in the appendix of the unit's Maintenance and Parts Manual.
 - If there is **partial cracking**, put the unit back into service. Order the Mounting Frame Reinforcement Kit, part number 991832504, and install it within 60 days of the inspection. Do not perform Inspection Procedures B. Inspect this area regularly as outlined in the Preventive Maintenance and Inspection Checklist in the appendix of the unit's Maintenance and Parts Manual.
 - If there is **full cracking**, take the unit out of service. The vehicle can still be driven, but the aerial device cannot be used until it is repaired. Proceed to Inspection Procedure B to determine the necessary repair procedure.

Inspection Procedure B

7. Keep the unit set up as in Inspection Procedure A step 1.
8. Use a wire brush to remove any paint and rust from the other three corners of the mounting frame (refer to Figure 4).

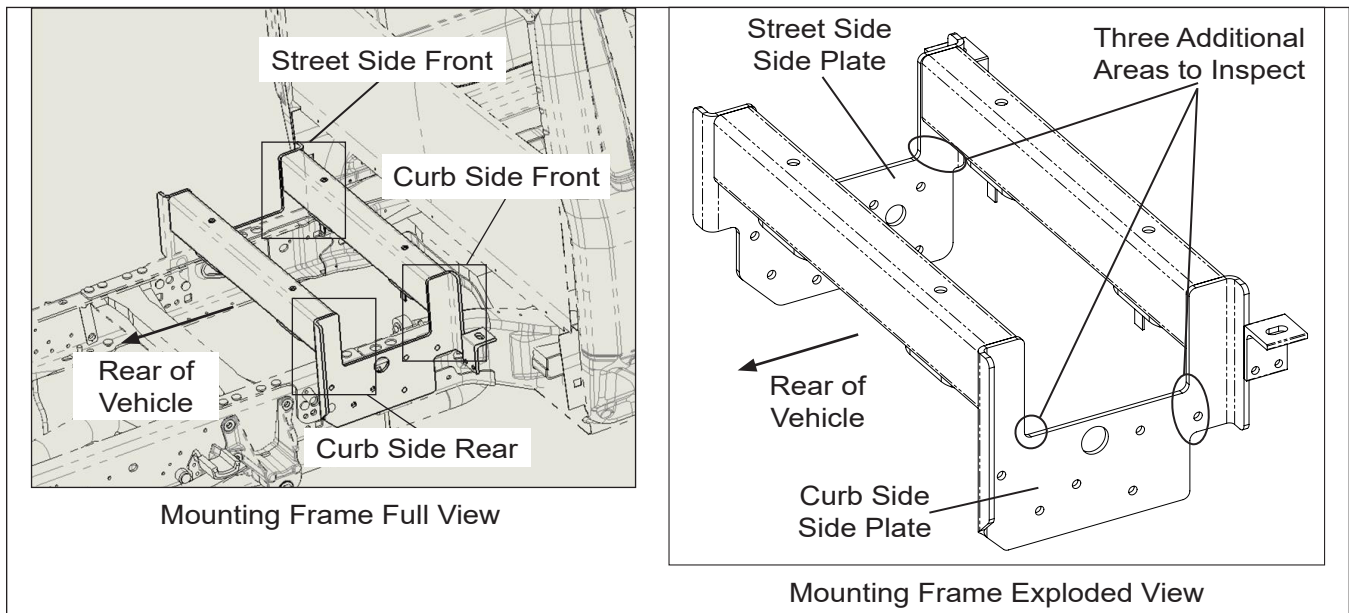

Figure 4 – Mounting Frame Additional Inspection B

9. Using a flashlight, inspect the outer surface and the rounded corners of the other three corners of the mounting frame as shown in Figure 4 for the extent of any cracking in the steel plate.
 - If there is no cracking in any of these three areas, order the Mounting Frame Reinforcement Kit, part number 991832504, and install it before putting the unit back into service.
 - If there is cracking in any of these three areas, call 1-270-505-1532 to speak to Telecom Product Support or email Telecom.Product.Support@altec.com to obtain further direction on repair.