



## **IMPORTANT SAFETY RECALL**

**Recall ID 21E-020**

**This is an important Safety Recall**

**The remedy will be provided to you at no charge**

CURT Manufacturing, LLC

6208 Industrial Drive

Eau Claire, WI 54701

www.curtmfg.com

Dear CURT Manufacturing LLC customer:

This notice is sent to you in accordance with the National Traffic and Motor Vehicle Safety Act.

CURT Manufacturing LLC ("CURT") has decided that a defect exists in certain CURT Ball & Pintle Hitches (CURT Part No. 48190 or 48200). You received this notice because your local CURT Ball & Pintle Hitch distributor or dealer has informed us that you may have purchased one of these pintle hitches.

The affected pintle mounts are marked as CURT Part No. 48190 or 48200.

**What is the Safety Defect and Safety Hazard? Due to an out of position pivot hole on the pintle body, the upper jaw latch position is higher than intended. This condition limits engagement of the locking pawl and may allow the upper jaw to unlatch under load. If this condition exists, the towed vehicle may separate, increasing the risk of a crash.**

**What will CURT Do? We will replace the ball & pintle hitch at no charge to you with a similar product.**

**What should you do? You should immediately take the following steps:**

- **You should first determine if you have one of the affected ball & pintle hitches (see 3<sup>rd</sup> page Inspection Process). If you are not sure, please contact CURT or your local distributor or dealer.**
- **If you have an affected ball & pintle hitch, you should stop using it immediately.**
- **Replacements or reimbursement can be obtained directly from CURT by:**
  - **Contacting CURT either by our website or calling CURT at the number below.**
  - **As a part of the replacement process:**
    - **You will be asked for information about when and where you purchased the affected pintle mount, as well as other information (your name, address, and telephone number);**
    - **You will be required to return the affected ball & pintle hitch to CURT. We will provide you with pre-paid return shipping instructions through UPS.**



- **Immediately upon our receipt of the returned affected ball & pintle hitch, CURT will send you a corrected replacement ball & pintle hitch.**

**What if I no longer own the CURT Ball & Pintle Hitch?** Please contact us immediately with the new owner's name, address and other contact information. Also, please forward this notice to the new owner within ten (10) days.

**What if you need further assistance?** For additional information, you may:

- Go to CURT's website: [www.curtmfg.com](http://www.curtmfg.com)
- Call CURT at 877-287-8634, option 2
- Contact your local CURT Ball & Pintle Hitch distributor or dealer

Please contact us immediately if you need any assistance with this recall. You may also contact the Administrator, National Highway Traffic Safety Administration at 1200 New Jersey Avenue, S.E., Washington DC 20591. The vehicle safety hotline 1-888-327-4236 (TTY: 1-800-424-9153) or go to <http://www.safercar.gov> if you believe that CURT or your local distributor or dealer have failed or are unable to remedy this defect without charge and within a reasonable amount of time.

Your continued satisfaction with your CURT Ball & Pintle Hitch is important to us. We have recalled the affected ball & pintle hitches in the interest of your safety, and to make sure your ball & pintle hitch performs properly. We apologize for this inconvenience, and ask that you complete the recall procedures as soon as possible.

Sincerely,

CURT Manufacturing, LLC

# INSPECTION PROCESS

## Step 1

Lower the locking arm until it rests on top of the hitch ball and ensure the locking pawl is in the latched position by installing the safety lynch pin as shown below.

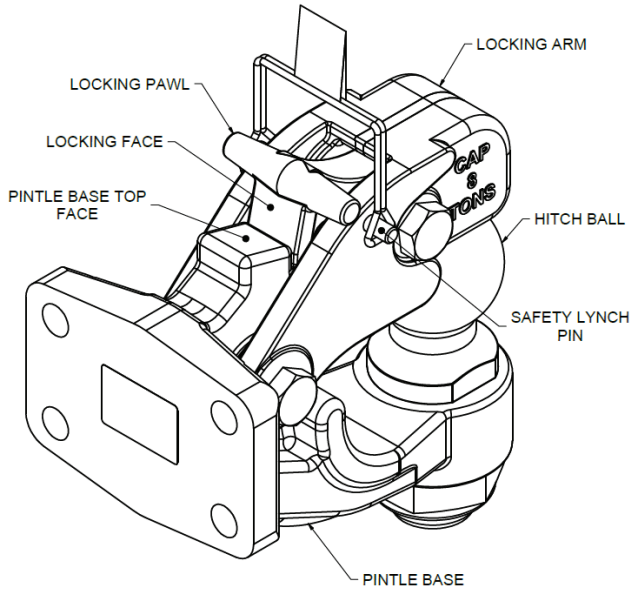

## Step 2 - Locked Position

Using a pencil, scribe a line on the locking face of the pawl using the adjacent top face of the pintle base as a guide. See below.

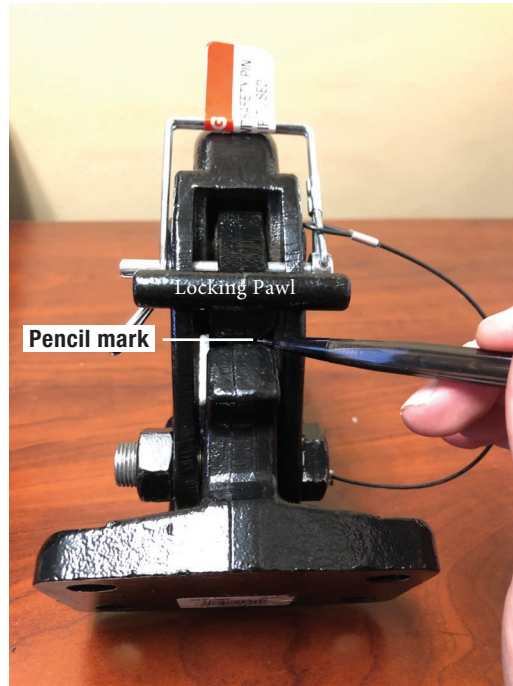

## Step 3 - Unlocked / Open Position

Remove the safety lynch pin. Lift the locking pawl and arm so the pawl is resting in the center of the top face of the pintle base as shown below.

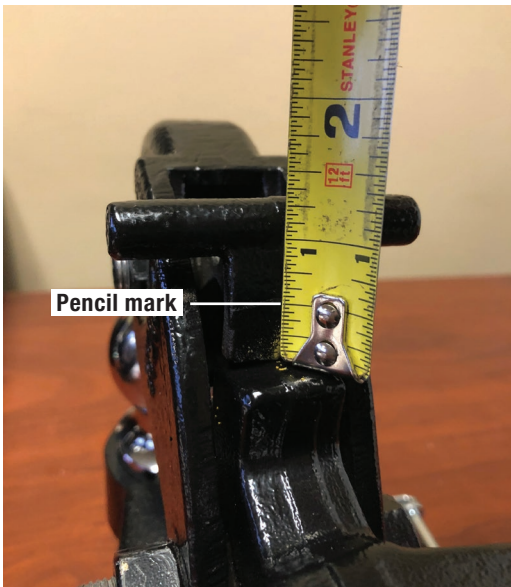

## Step 4

Using a tape measure, ensure the center of scribed line is a minimum of 3/8in (9.5mm) from the bottom face of the pawl as shown in Figure 3. If the measurement is greater than 3/8in (9.5mm), the part is safe for continued use.

**IMPORTANT:** If the measurement to scribed line in Step 4 is less than 3/8" (9.5mm), immediately discontinue use and return the part to CURT for replacement.

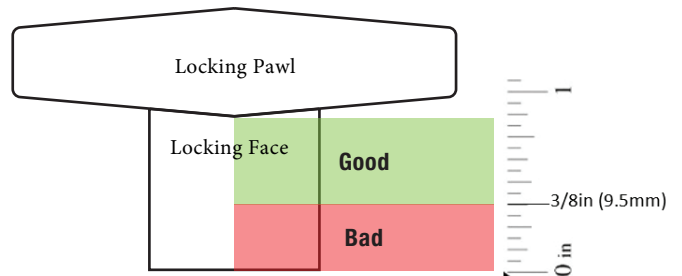

## NOTICE

If you have any questions regarding the inspection process please contact CURT Product Support for assistance at 877.287.8634, option 2.