



David J. Johnson  
Director  
Service Engineering Operations  
Ford Customer Service Division

Ford Motor Company  
P. O. Box 1904  
Dearborn, Michigan 48121

January 21, 2022

**TO:** All U.S. Ford and Lincoln Dealers

**SUBJECT:** **NEW VEHICLE DEMONSTRATION / DELIVERY HOLD**  
**Compliance Recall 21C23 – Supplement #1**  
Certain 2021 Model Year Bronco  
Front Passenger Air Bag Replacement

**REF:** **NEW VEHICLE DEMONSTRATION / DELIVERY HOLD**  
**Compliance Recall 21C23**  
Dated: December 20, 2021

**New! REASON FOR THIS SUPPLEMENT**

*Some of the affected vehicles were repaired at the plant and inadvertently left in this recall, these units have been removed from OASIS and online VIN listing. Please review OASIS to verify if vehicle is still in the program. If the vehicle is no longer in the program and repairs are started or completed before a claim was submitted, contact SSSC for further direction.*

**AFFECTED VEHICLES**

| Vehicle | Model Year | Assembly Plant | Build Dates                           |
|---------|------------|----------------|---------------------------------------|
| Bronco  | 2021       | Michigan       | July 18, 2021 through August 17, 2021 |

Affected vehicles are identified in OASIS and FSA VIN Lists.

**REASON FOR THIS COMPLIANCE RECALL**

Some of the affected vehicles may not conform to the requirements specified by Federal Motor Vehicle Safety Standard (FMVSS) No. 208 Occupant Protection. The front passenger air bag may have been incorrectly folded during manufacturing. Incorrect folding may cause improper deployment of the airbag, increasing the risk of occupant injury during a crash.

**SERVICE ACTION**

Before demonstrating or delivering any new in-stock vehicles involved in this recall, dealers are to replace the front passenger air bag using technical instructions. This service must be performed on all affected vehicles at no charge to the vehicle owner.

**New! OWNER NOTIFICATION MAILING SCHEDULE**

*Owner letters for vehicles no longer in the program will be mailed week of January 31, 2022. Another owner letter for remainder of customers will be mailed when parts are available to support this compliance recall.*

**PLEASE NOTE:**

**Federal law requires dealers to complete this recall service before a new vehicle is delivered to the buyer or lessee. Violation of this requirement by a dealer could result in a civil penalty of up to \$21,000 per vehicle. Correct all vehicles in your new vehicle inventory before delivery.**

## **ATTACHMENTS**

Attachment I: Administrative Information  
Attachment II: Labor Allowances and Parts Ordering Information  
Attachment III: Technical Information  
Owner Notification Letters

## **QUESTIONS & ASSISTANCE**

For questions and assistance, contact the Special Service Support Center (SSSC) via the SSSC Web Contact Site. The SSSC Web Contact Site can be accessed through the Professional Technician System (PTS) website using the SSSC link listed at the bottom of the OASIS VIN report screen or listed under the SSSC tab.

Sincerely,

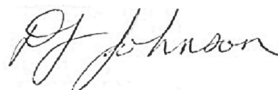
A handwritten signature in cursive script that reads "D. Johnson".

David J. Johnson

**NEW VEHICLE DEMONSTRATION / DELIVERY HOLD**  
**Compliance Recall 21C23 – Supplement #1**  
Certain 2021 Model Year Bronco  
Front Passenger Air Bag Replacement

**OASIS ACTIVATION**

OASIS was activated on October 4, 2021.

**FSA VIN LISTS ACTIVATION**

FSA VIN Lists were made available through <https://web.fsavinlists.dealerconnection.com> on October 4, 2021. Owner names and addresses will be available by week of January 31, 2022.

**NOTE:** Your FSA VIN Lists may contain owner names and addresses obtained from motor vehicle registration records. The use of such motor vehicle registration data for any purpose other than in connection with this recall is a violation of law in several states, provinces, and countries. Accordingly, you must limit the use of this listing to the follow-up necessary to complete this recall.

**SOLD VEHICLES**

- Ford has not issued instructions to stop selling/delivering or driving used vehicles under this compliance recall. Owners should contact their dealer for an appointment to have their vehicles remedied as soon as practicable. Owners can continue to safely drive their vehicles.
- Immediately contact any of your affected customers whose vehicles are not on your VIN list but are identified in OASIS. Give the customer a copy of the Owner Notification Letter (when available) and schedule a service date.
- Correct other affected vehicles identified in OASIS which are brought to your dealership.
- Dealers are to prioritize repairs of customer vehicles over repairs of new and used vehicle inventory.

**STOCK VEHICLES**

- Correct all affected units in your new vehicle inventory before delivery.
- Use OASIS to identify any affected vehicles in your used vehicle inventory.

**DEALER-OPERATED RENTAL VEHICLES**

The Fixing America's Surface Transportation (FAST) Act law effective June 2016 prohibits a rental company from selling, renting or leasing vehicles subject to a safety or compliance recall. Please consult your legal counsel for legal advice.

**TITLE BRANDED / SALVAGED VEHICLES**

Affected title branded and salvaged vehicles are eligible for this recall.

**OWNER REFUNDS**

Refunds are not approved for this program.

**RENTAL VEHICLES**

Rental vehicles are not approved for this program.

**NEW VEHICLE DEMONSTRATION / DELIVERY HOLD**  
**Compliance Recall 21C23 – Supplement #1**  
Certain 2021 Model Year Bronco  
Front Passenger Air Bag Replacement

**ADDITIONAL REPAIR (LABOR TIME AND/OR PARTS)**

Additional repairs identified as necessary to complete the FSA should be managed as follows:

- For related damage and access time requirements, refer to the Warranty and Policy Manual / Section 6 – Ford & Lincoln Program Policies / General Information & Special Circumstances for FSA's / Related Damage.
- For vehicles within new vehicle bumper-to-bumper warranty coverage, no SSSC approval is required, although related damage must be on a separate repair line with the "Related Damage" radio button checked.
  - Ford vehicles – 3 years or 36,000 miles
- For vehicles outside new vehicle bumper-to-bumper warranty coverage, submit an Approval Request to the SSSC Web Contact Site prior to completing the repair.

**CLAIMS PREPARATION AND SUBMISSION**

- **Claim Entry:** Enter claims using Dealer Management System (DMS) or One Warranty Solution (OWS) online.
  - When entering claims, select claim type 31: Field Service Action. The FSA number 21C23 is the sub code.
  - For additional claims preparation and submission information, refer to the Recall and Customer Satisfaction Program (CSP) Repairs in the OWS User Guide.
- **Related Damage/Additional labor and/or parts:** Must be claimed as Related Damage on a separate repair line from the FSA with same claim type and sub code as described in Claim Entry above.

**IMPORTANT:** Click the Related Damage Indicator radio button.

**NEW VEHICLE DEMONSTRATION / DELIVERY HOLD**  
**Compliance Recall 21C23 – Supplement #1**  
 Certain 2021 Model Year Bronco  
 Front Passenger Air Bag Replacement

**LABOR ALLOWANCES**

| Description  | Labor Operation | Labor Time |
|--|-----------------|------------|
| Replace Passenger Side Air Bag (includes time for taking pictures) | 21C23B          | 1.7 Hours  |

**PARTS REQUIREMENTS / ORDERING INFORMATION**

| Part Number       | Description   | Order Quantity | Claim Quantity |
|-------------------|---|----------------|----------------|
| M2DZ-78044A74-B   | Front Passenger Air Bag   | 1              | 1              |
| M2DZ-7804338-AR\$ | Center Instrument Trim Panel (8" Touch Screen, Black Diamond, Big Bend, Badlands, Wildtrak, Base) | 1              | 1              |
| M2DZ-7804338-AS   | Center Instrument Trim Panel (8" Touch Screen, Outer Banks)                                       |                |                |
| M2DZ-7804338-BY   | Center Instrument Trim Panel (12" Touch Screen, Badlands, Wildtrak)                               |                |                |
| M2DZ-7804338-BZ   | Center Instrument Trim Panel (12" Touch Screen, Outer Banks)                                      |                |                |

Order your parts through normal order processing channels. To guarantee the shortest delivery time, an emergency order for parts must be placed.

**DEALER PRICE**

For latest prices, refer to DOES II.

**PARTS RETENTION, RETURN, & SCRAPPING**

Follow the provisions of the Warranty and Policy Manual, Section 1 - WARRANTY PARTS RETENTION AND RETURN POLICIES. If a replaced part receives a scrap disposition, the part must be scrapped in accordance with all applicable local, state and federal environmental protection and hazardous material regulations. Federal law prohibits selling motor vehicle parts or components that are under safety, compliance, or emissions recall.

**EXCESS STOCK RETURN**

Excess stock returned for credit must have been purchased from Ford Customer Service Division in accordance with Policy Procedure Bulletin 4000.

**NEW VEHICLE DEMONSTRATION / DELIVERY HOLD**  
**Compliance Recall 21C23 – Supplement #1**  
Certain 2021 Model Year Bronco  
Front Passenger Air Bag Replacement

**REPLACED FSA PARTS INSPECTION AND SIGN OFF**

Effective March 1<sup>st</sup> 2021 all parts replaced as part of an FSA repair with a repair order open date of March 1<sup>st</sup> 2021 or later must be inspected and signed off on the repair order by a member of your dealers fixed operations management team or an employee the task has been delegated to. If the task is to be delegated to a non-management employee, the employee needs to be someone other than the technician who completed the repair and needs to understand the importance of completing this task consistently and accurately.

- All parts replaced as part of an FSA repair should be returned to the parts department following the Warranty Parts Retention and Return Policies.
- Inspect the replaced parts to verify the FSA repair was completed.
- If the FSA repair is found to be complete, the designated employee signs the repair order line or parts return stamp area (electronic or hand signed) for the FSA repair indicating the parts were inspected and validated to have been replaced.
- After the parts have been inspected, they should be handled based on the guidance in the parts status report in the Online Warranty System (Hold, Return, CORE, Scrap, etc.).
- This process is subject to review during warranty audits for FSA repairs with a repair order open date of March 1<sup>st</sup> 2021 or later. Any eligible FSA claims requiring parts replacement, found not to have been inspected and signed off during a warranty audit will be subject to chargeback and consideration for enrollment into the Dealer Incomplete Recall Repair Process.

**Note:** Other approvals (electronic or handwritten) for add-on repair lines, dealer owned vehicle repairs, and repeat repairs do not qualify as FSA parts inspection approvals. The post repair FSA parts inspection process (electronic or handwritten) is independent from other warranty approval requirements. The approval by the designated employee implies that the FSA parts were found to be replaced and must be able to be clearly identified on the Repair Order. If multiple FSA's require approval on a single Repair Order, each applicable occurrence will require individual post repair approval by the designated employee.

## CERTAIN 2021 MODEL YEAR BRONCO VEHICLES — FRONT PASSENGER AIR BAG REPLACEMENT

### SERVICE PROCEDURE

**⚠ WARNING:** The following procedure prescribes critical repair steps required for correct restraint system operation during a crash. Follow all notes and steps carefully. Failure to follow step instructions may result in incorrect operation of the restraint system and increases the risk of serious personal injury or death in a crash.

**⚠ WARNING:** Before beginning any service procedure in this manual, refer to health and safety warnings in section 100-00 General Information. Failure to follow this instruction may result in serious personal injury

1. Depower the Supplemental Restraint System (SRS) Depowering. Please follow Workshop Manual (WSM) procedures in section 501-20B.
2. Release the clips and lower the steering column trim panel. Then disconnect the electrical connectors and fully lower the trim panel. See Figure 1.

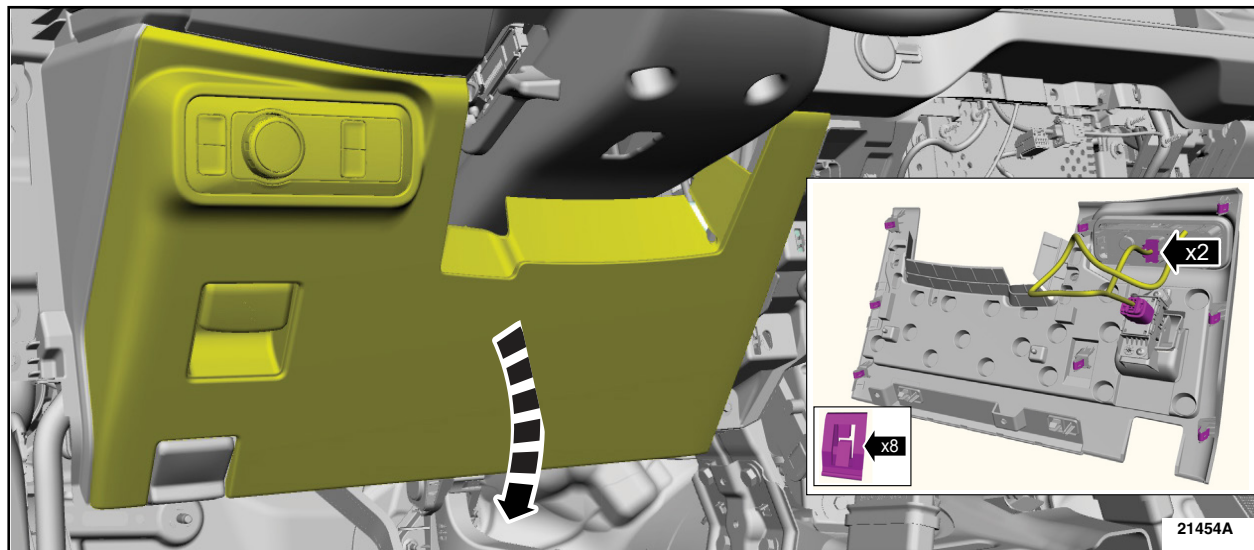
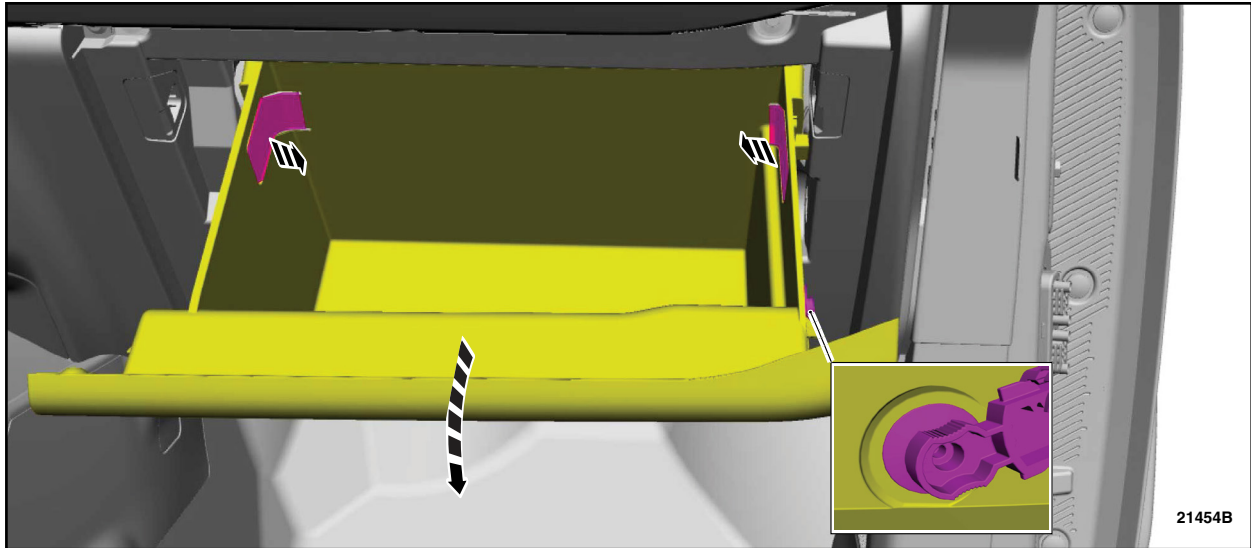

FIGURE 1



3. Open the glove compartment, remove the dampener, and release the stop tabs and fully lower the glove box. See Figure 2.



**FIGURE 2**

4. If equipped remove the screws and the console handle. See Figure 3.

- Torque 48 lb.in (5.4 Nm).

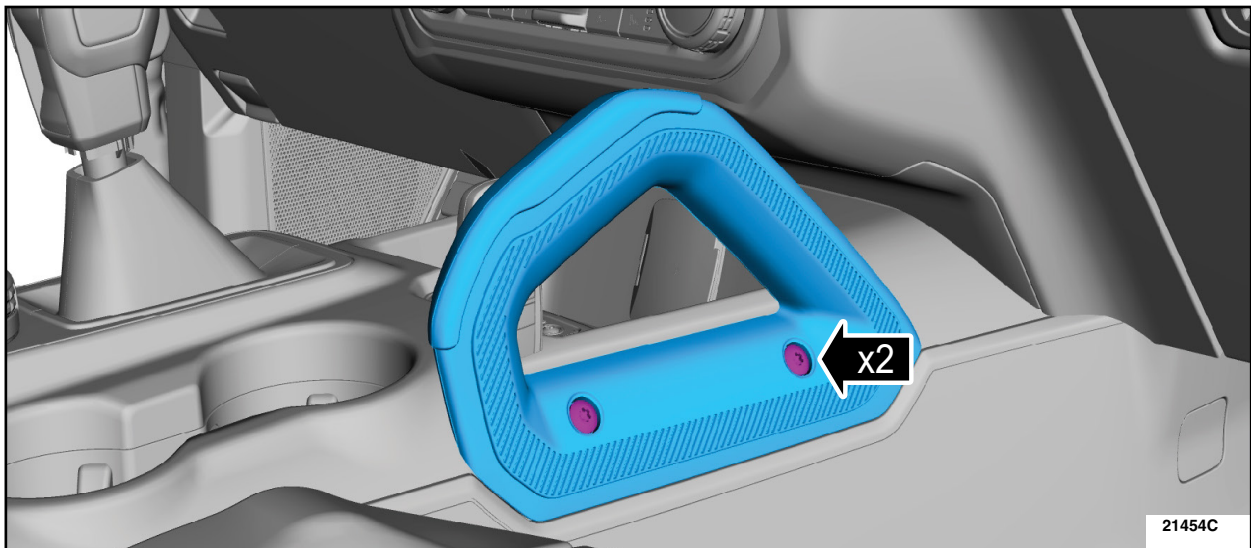

**FIGURE 3**





5. Remove the bolts, release the clips remove the lower center instrument panel trim panel, and disconnect the electrical connectors. See Figure 4.

- Torque 22 lb.in (2.5 Nm).

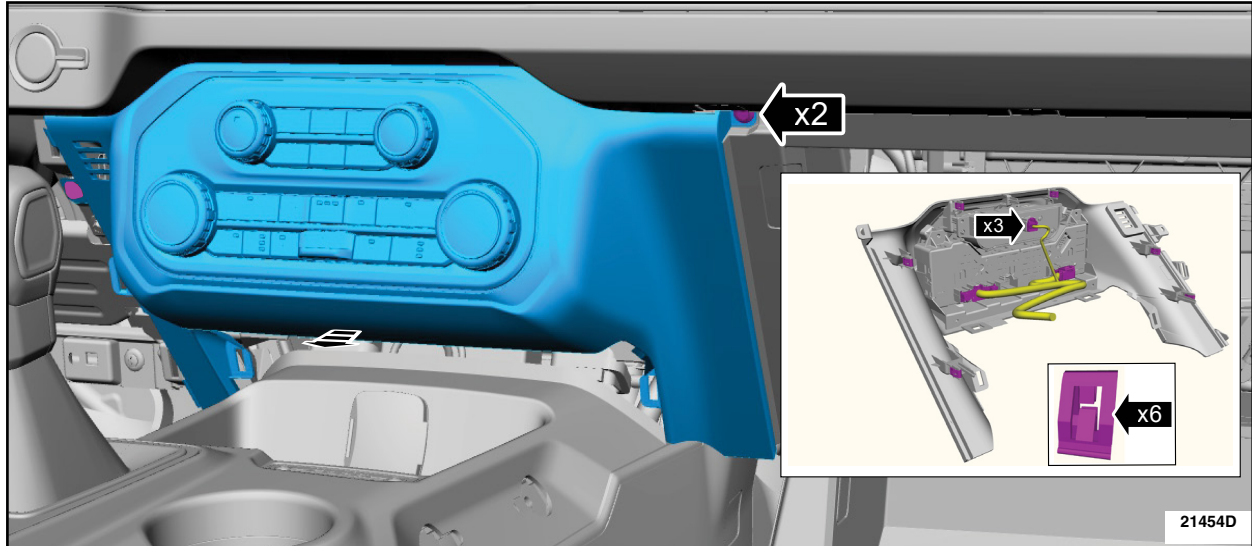

**FIGURE 4**

6. On both sides remove the screws, release the clips and remove the assist handles. See Figure 5.

- Torque 80 lb.in (9 Nm).

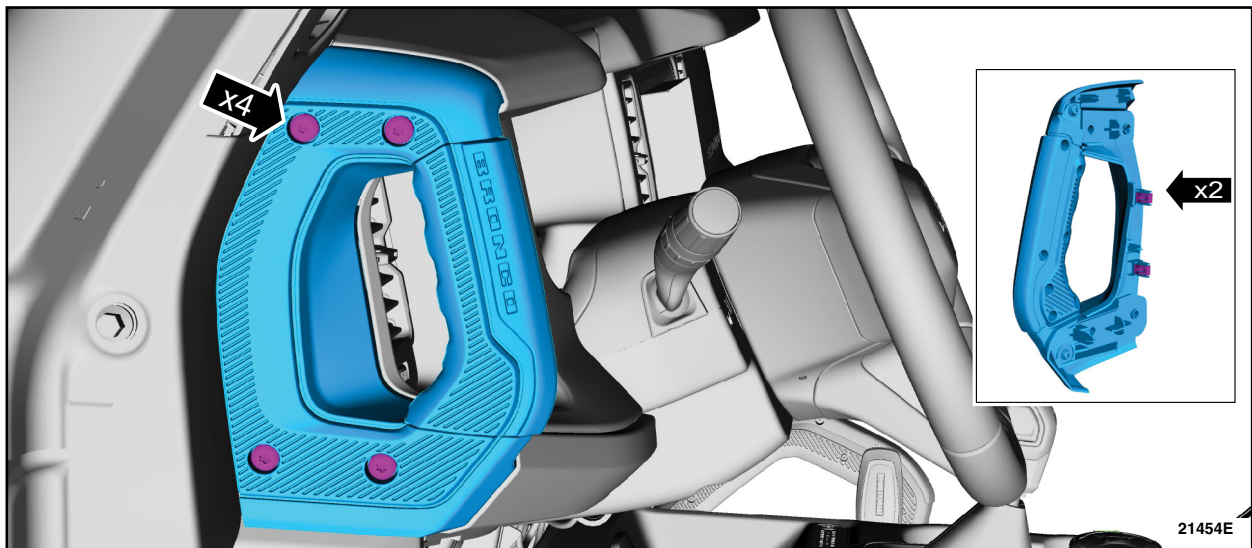

**FIGURE 5**



7. Disengage the access covers and remove the lower trim panel bolts. See Figure 6.

- Torque 22 lb.in (2.5 Nm).

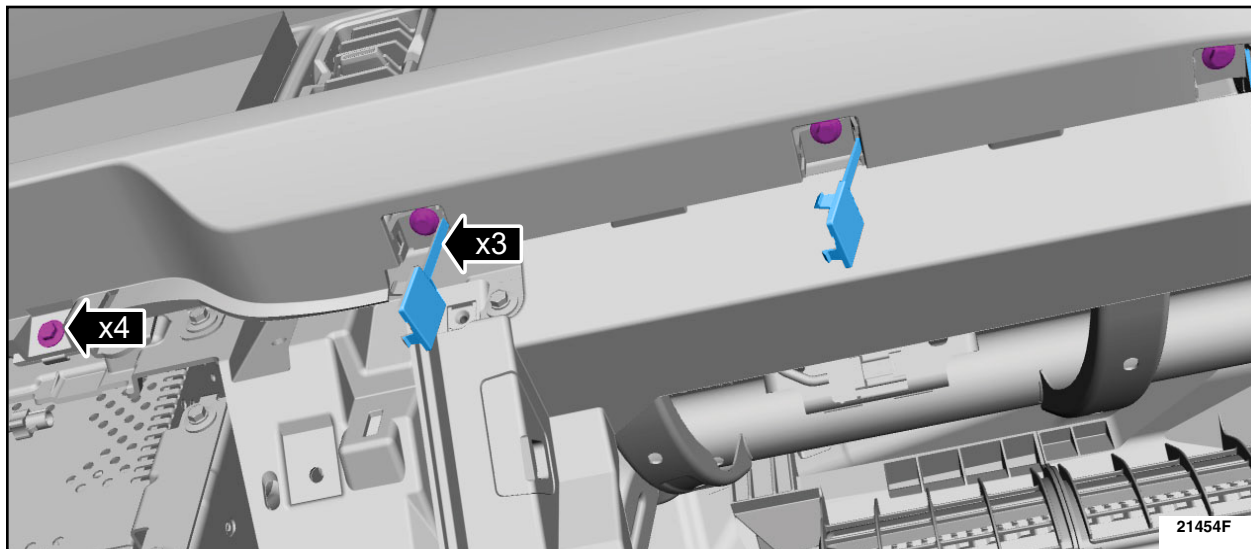

FIGURE 6

**NOTE:** Remove the lower trim panel by releasing the clips starting on the driver side and working towards the passenger side. Slide the lower trim panel towards the passenger side once all clips are released and disconnect the electrical connector to remove the lower trim panel. See Figure 7.

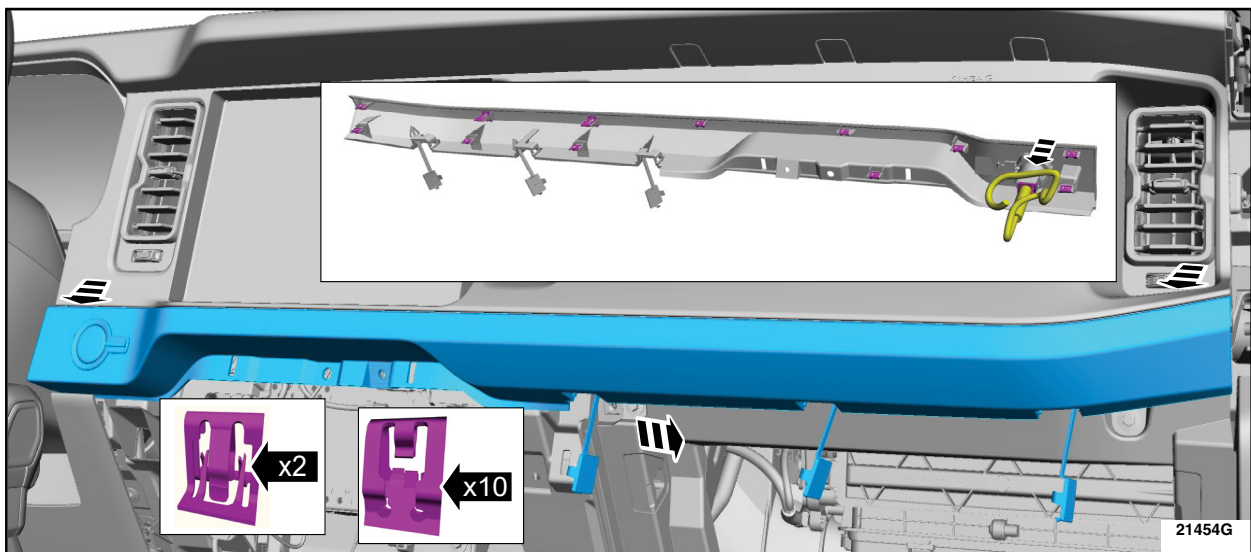

FIGURE 7



8. Release the instrument panel switch pack, disconnect the electrical connector and remove the instrument panel switch pack. See Figure 8.

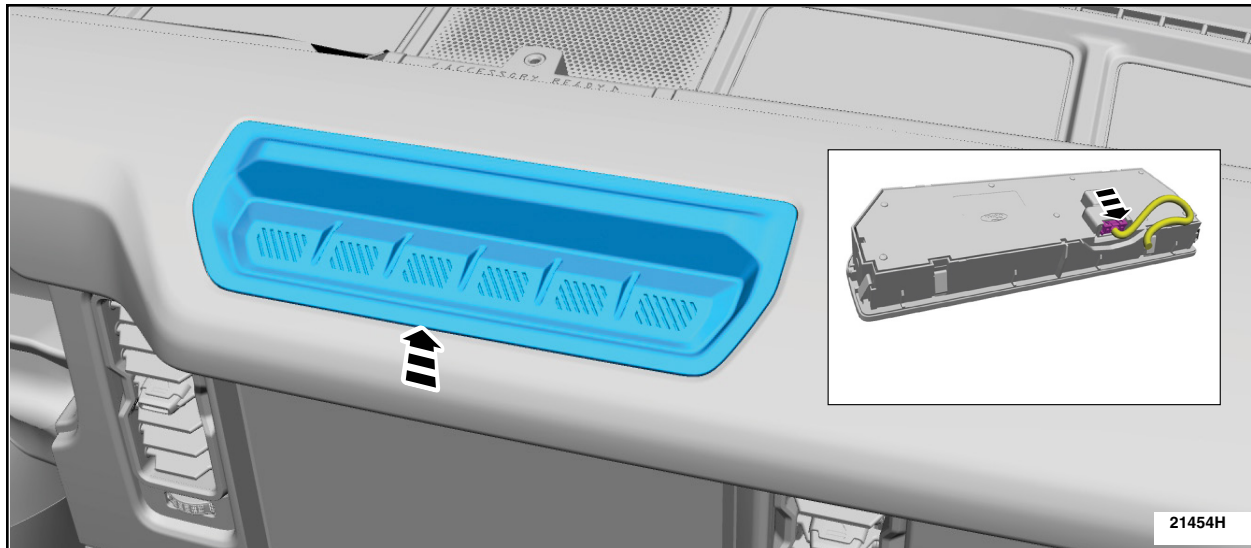

FIGURE 8

9. On both sides release the clips and remove the instrument panel speaker grilles. See Figure 9.

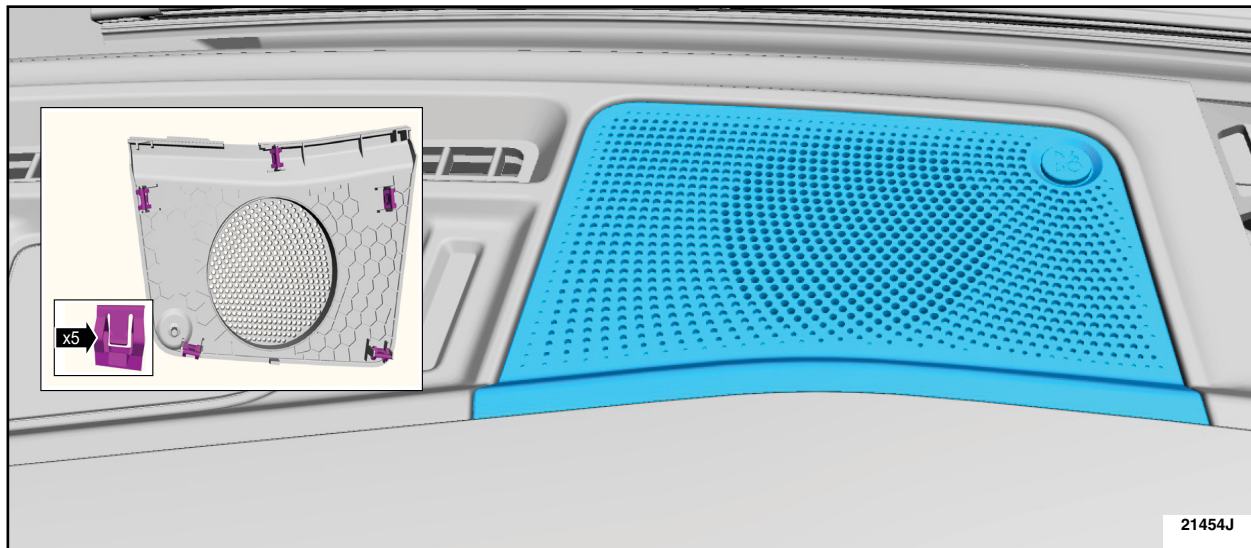
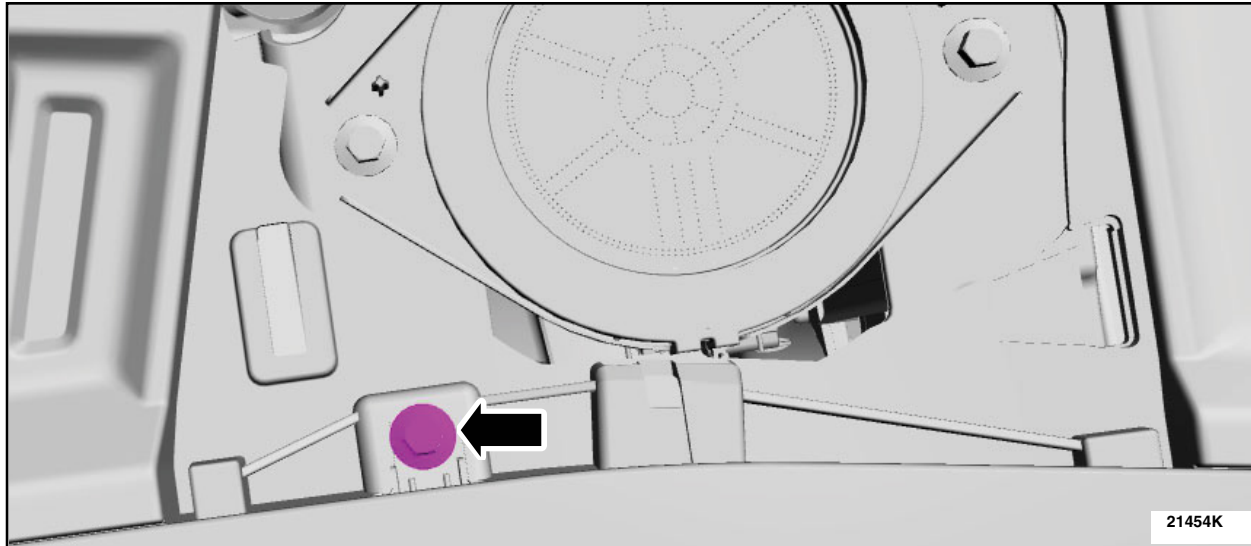

FIGURE 9



10. Remove the bolt. See Figure 10.

- Torque 22 lb.in (2.5 Nm).



**FIGURE 10**

11. Position aside the bolt covers and remove the bolts. See Figure 11.

- Torque 22 lb.in (2.5 Nm).

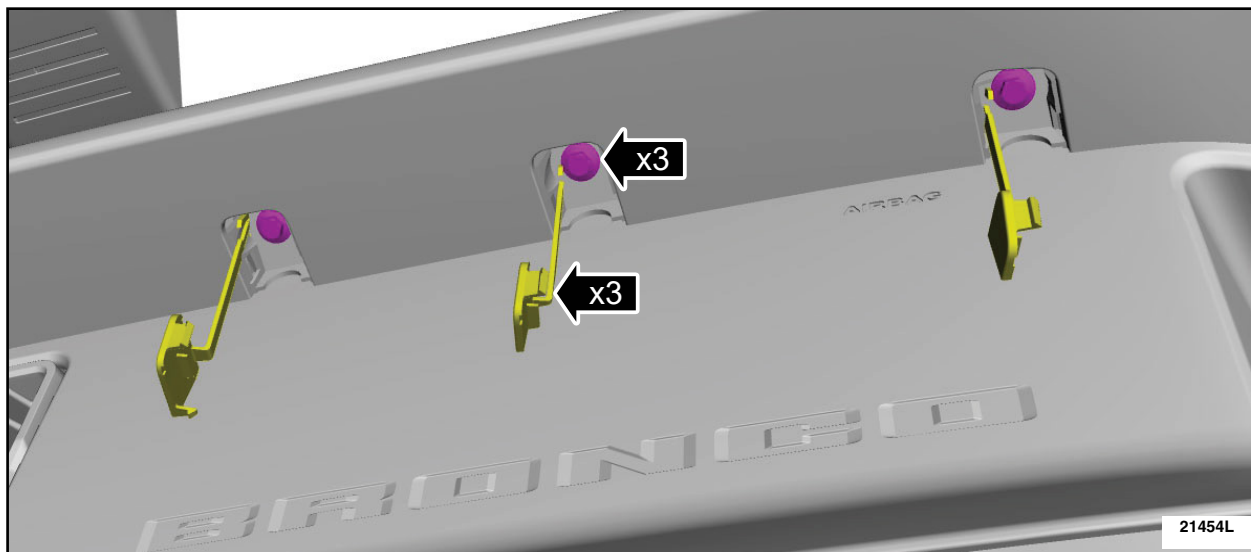

**FIGURE 11**



12. Remove the bolt, release the clips and remove the upper trim panel. See Figure 12.

- Torque 22 lb.in (2.5 Nm).

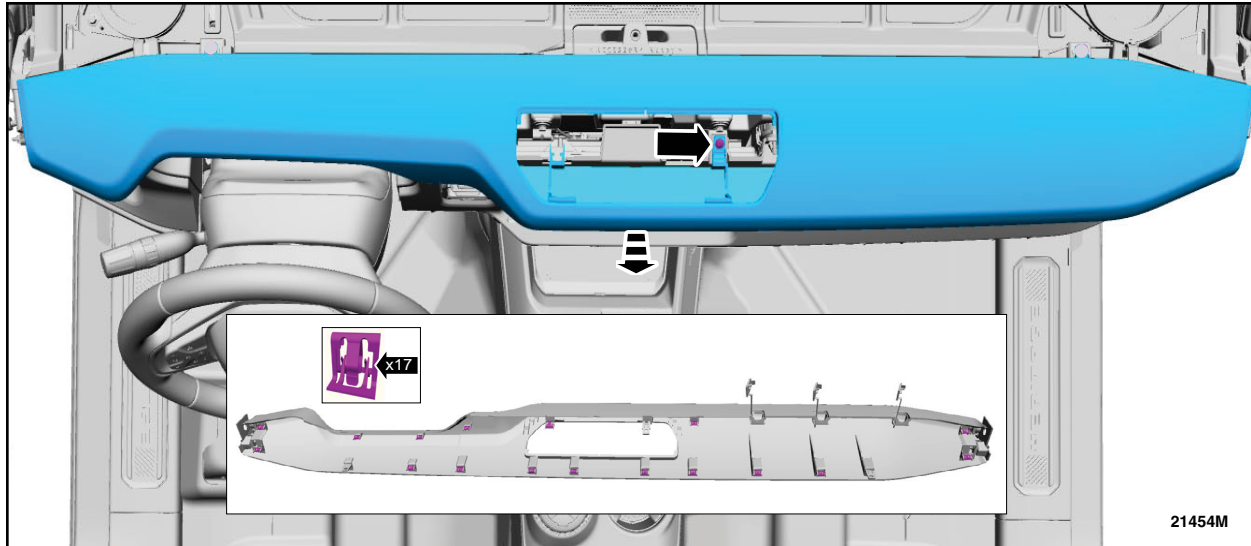

FIGURE 12

13. Remove the upper passenger side air bag bracket bolts. See Figure 13.

- Torque 93 lb.in (10.5 Nm).

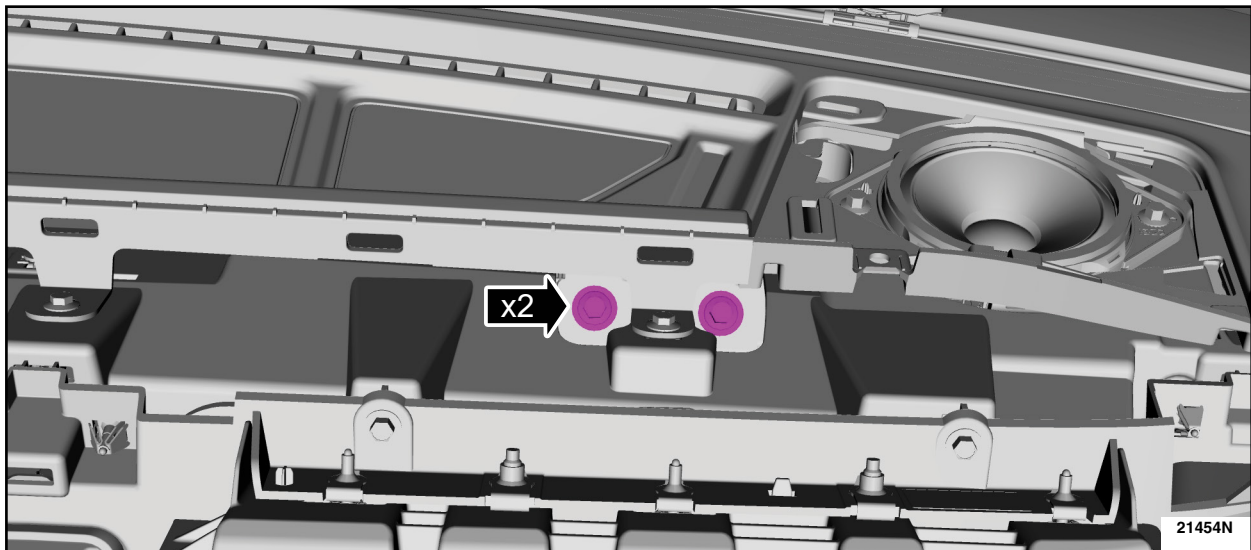

FIGURE 13



14. Disengage the wire harness retainer, disconnect the electrical connector and remove the lower passenger side air bag bracket bolts. See Figure 14.

- Torque 93 lb.in (10.5 Nm).

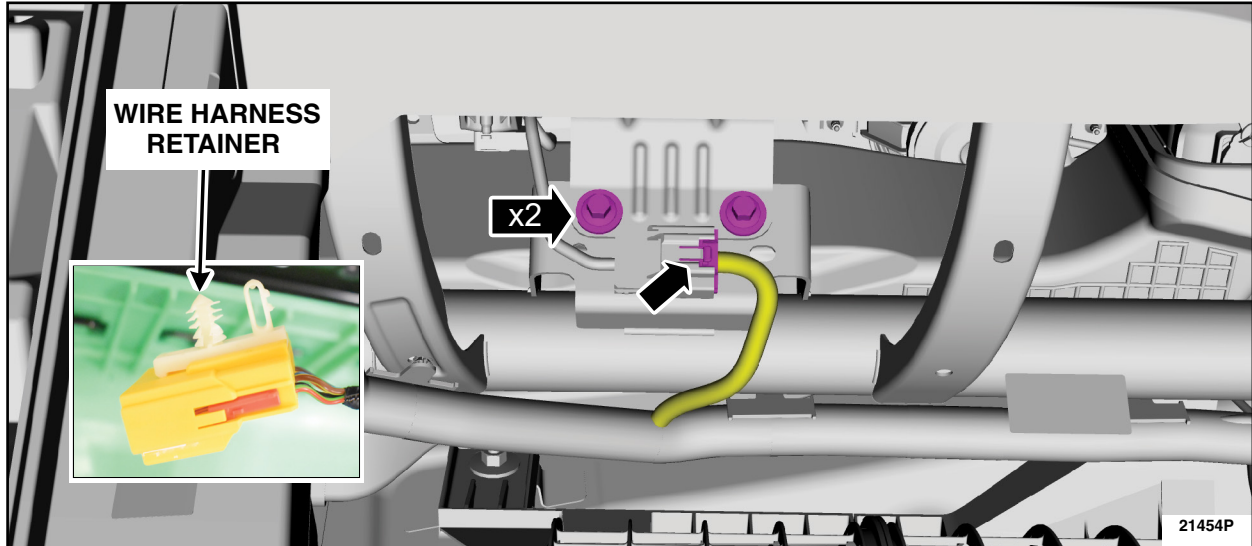

FIGURE 14

15. Remove the Right Hand (RH) center middle instrument trim panel lower screws. See Figure 15.

- Torque 22 lb.in (2.5 Nm).

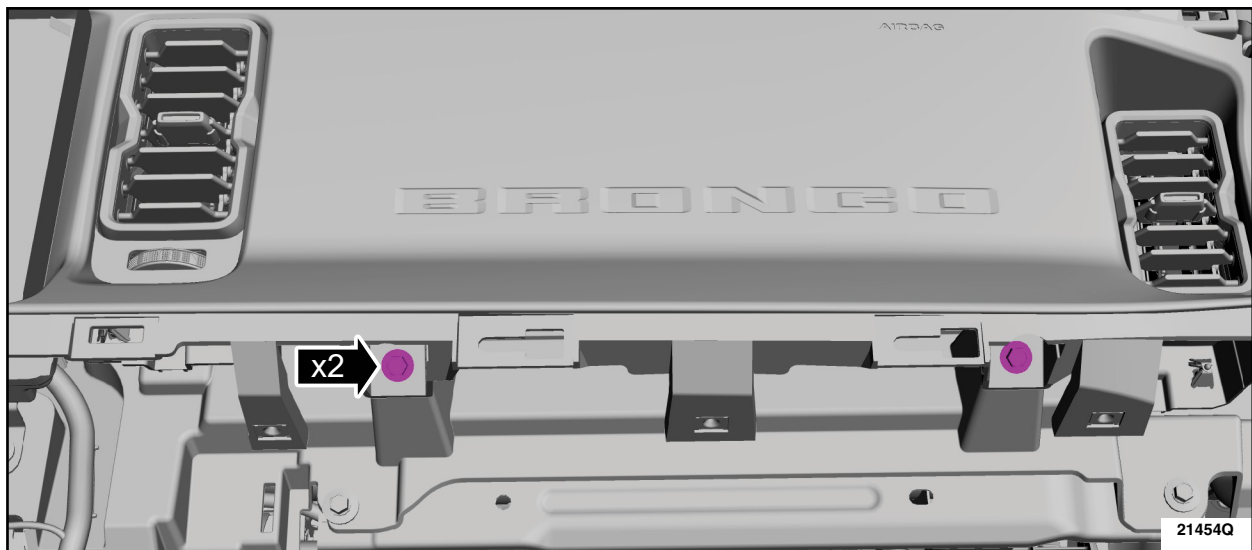

FIGURE 15



16. Remove the bolts, release the clips and remove the center middle instrument trim panel.  
See Figure 16.

- Torque 22 lb.in (2.5 Nm).

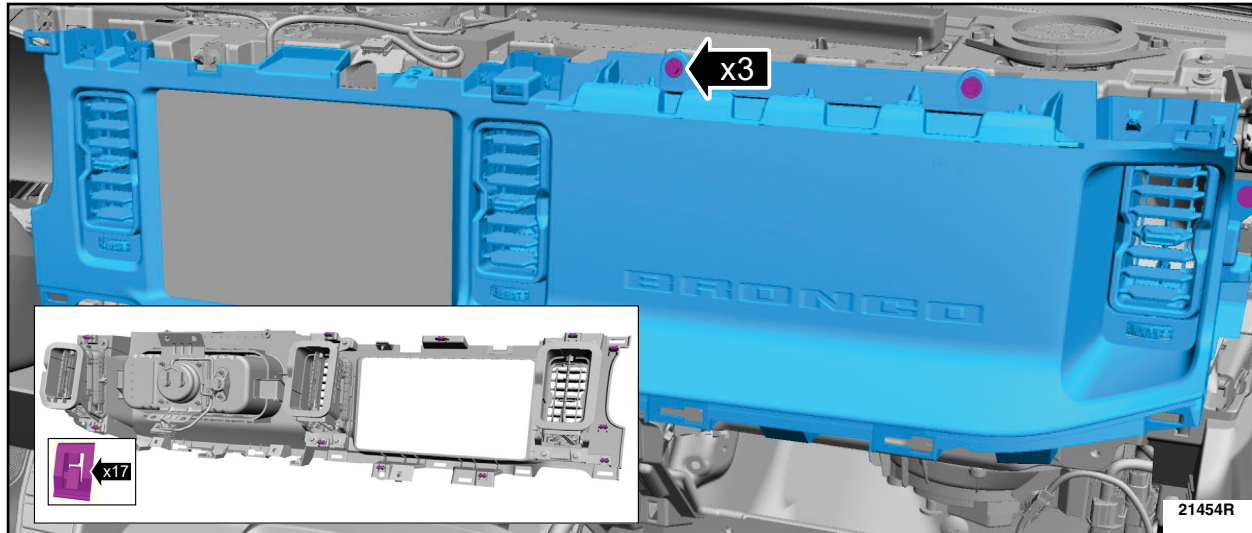

FIGURE 16

17. Remove the register vents and transfer them to the *new* center middle instrument trim panel.  
See Figure 17.

- Torque:
  - A) 22 lb.in (2.5 Nm).
  - B) 9 lb.in (1.1 Nm).

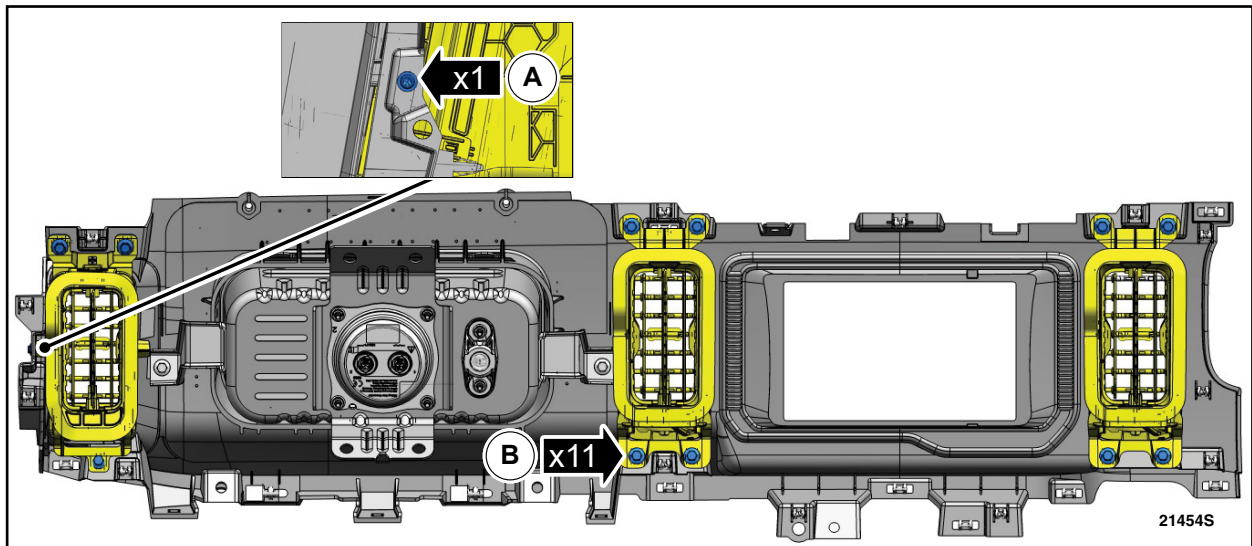
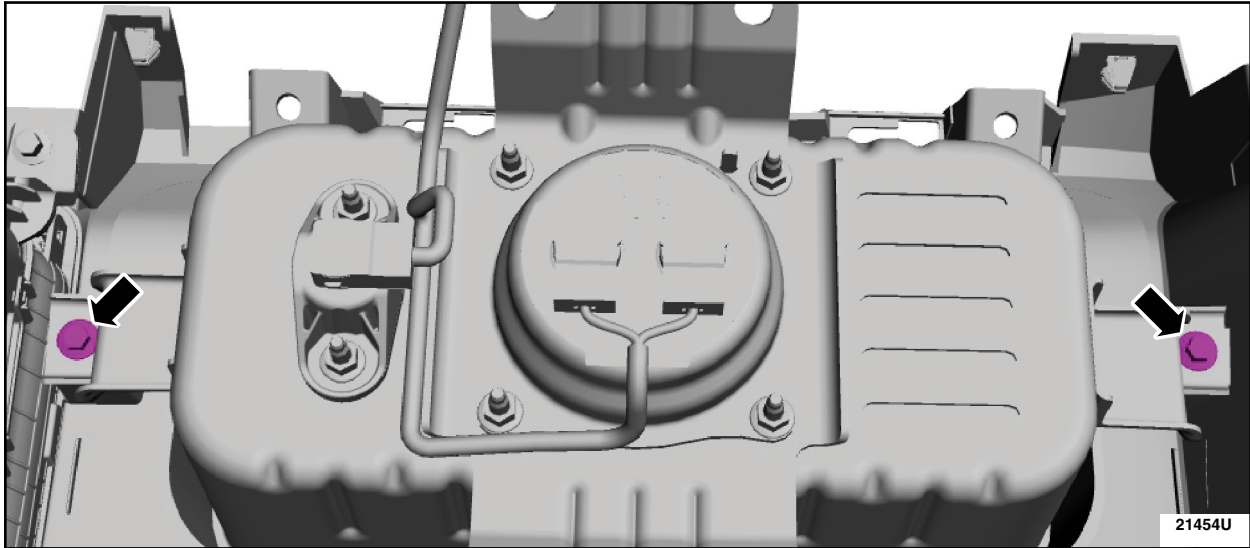

FIGURE 17



18. Remove the passenger airbag anti-rattle bracket screws. See Figure 18.

- Torque: 22 lb.in (2.5 Nm).



**FIGURE 18**

19. Install the *new* Passenger Airbag Module (PAB), and *new* center middle instrument trim panel by reversing the removal procedure.

20. Repower the SRS. Please follow WSM procedures in section 501-20B.





22. Submit a readable photo of the serial number from the original air bag assembly. See Figure 19.

- Dealers must submit their photos via Concern Reports using the "Report a Vehicle Concern" process. Concern Reports may be submitted via Web Based PTS or through Mobile PTS using any mobile device (e.g., tablets, smart phones).

**IMPORTANT:** The completed Concern Report 12 digit control number must be recorded on the work order for claiming purposes. Claims with incomplete Concern Reporting will be subject to chargeback.

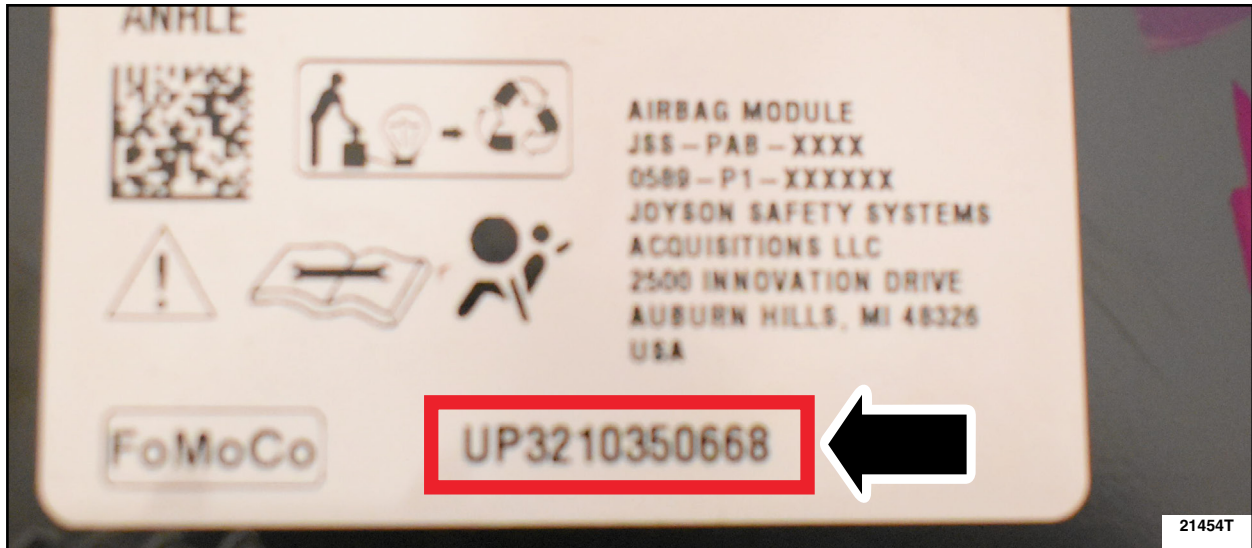

FIGURE 19



### Using Web Based “Report a Vehicle Concern”

- Access report entry form from link in PTS (Report a Vehicle Concern) or directly at: <https://www.gcr.dealerconnection.com/asp/FordDealerMenu.asp>
- Ensure that your “User Profile” is added/updated to include your STARS ID. This can be done by accessing your User Profile from the Global Concern Reporting Main Menu or directly at: <https://www.gcr.dealerconnection.com/asp/DealerProfile.asp>
- After completing the report entry form and submitting your report, you can upload a maximum of 5 attachments at once. The attachments must be saved to the drive on the Personal Computer (PC) you are using.

### Using Mobile PTS “Report a Vehicle Concern”

**IMPORTANT** - If you have never used the Web-Based report a vehicle concern you will need to create your User Profile prior to accessing “Report a Vehicle Concern” on Mobile PTS.

Ensure that your “User Profile” is added/updated to include your STARS ID. This can be done by accessing your User Profile directly at: <https://www.gcr.dealerconnection.com/asp/DealerProfile.asp> ; You can access Mobile PTS using your mobile device at: <https://m.fordtechservice.dealerconnection.com/> or the following QR code:



After completing the report entry form you can upload a maximum of 5 attachments at once.

- If submitting more than one attachment (photo), the files must be saved to the mobile device you’re using, PRIOR to submitting the report.
- If submitting one attachment (photo), you can capture the photo during the report submission when asked to add the attachment.

**IMPORTANT NOTE: Federal law prohibits selling motor vehicle parts or components that are under safety, compliance, or emissions recall. Unless a part is requested to be returned to Ford, all parts replaced under this FSA must be scrapped in accordance with all applicable local, state and federal environmental protection and hazardous material regulations. Refer to the Parts Retention, Return, & Scrapping section of the FSA dealer bulletin for further information.**

