



Luxe Trucks dba Utility Bodywerks

3504 HENKE STREET

ELKHART, IN 46514

PH: 574-522-8422, FAX: 574-389-1282

www.utilitybodywerks.com

Important Safety Recall

NHTSA Recall Number: 21V-634

Date: July 1, 2022

Subject: RAM Rear Brake Caliper Flexible Line Modification Safety Recall Notice

Dear LiquidSpring Suspension Owner,

This notice is being sent to you in accordance with the requirements of the National Highway Traffic and Motor Vehicle Safety Act. Luxe Trucks dba Utility Bodywerks performed the suspension installation work on your vehicle and is also required by NHTSA to inform you of this recall and remedy accordingly.

LiquidSpring LLC has determined that a defect which relates to motor vehicle safety exists in a component of certain LS suspension systems installed on 2019-20 model year RAM 4500/5500 cab chassis, and only suspension systems installed on the above chassis are included in the safety recall.

These suspension systems are typically installed on ambulances and other specialty vehicles. The affected system component is the rear brake caliper flexible line. The routing of the rear brake caliper flexible lines during the installation of the suspension kit may be causing brake caliper flexible line wear due to contact with a suspension component(s). Continued vehicle use with the rear brake caliper flexible line contacting suspension a component(s) may result in partial or complete loss of rear service brakes which could cause damage to the chassis and/or other vehicles, and possibly result in a crash.

You are receiving this notice because records indicate that you may have purchased a vehicle equipped with an affected LS suspension system. LiquidSpring recommends that vehicle operator(s) be aware of any abnormal brake pedal feedback or reduced braking ability and that the rear brake caliper flexible lines should be inspected for any leakage. If any wear is found on the rear brake caliper flexible lines (not the protective spiral wrap), do not drive the vehicle.

The affected suspension systems have a serial number range 2007563 – 2013191. The suspension system serial number may be found on the serial number plate located on the driver side front frame hanger of the suspension. See Figures 2 & 3 for the location and view of the serial number plate.



Luxe Trucks dba Utility Bodywerks

3504 HENKE STREET
ELKHART, IN 46514
PH: 574-522-8422, FAX: 574-389-1282
www.utilitybodywerks.com

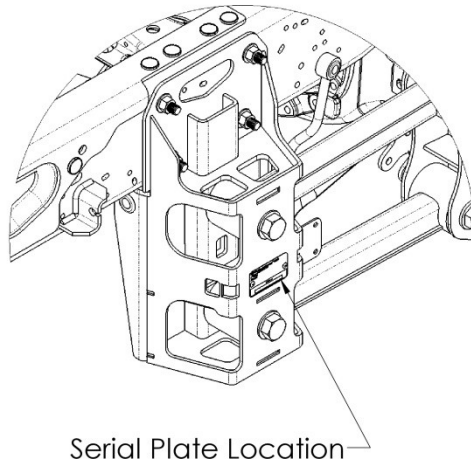

Serial Plate Location

Figure 2. Serial Plate Location



Figure 3. Serial Plate

If you have a 2019-20 model year RAM 4500/5500 cab chassis equipped with a LiquidSpring suspension system within the above serial number range, please contact Luxe Trucks dba Utility Bodywerks to arrange service to have the rear brake caliper flexible lines inspected and modified to address the potential wear issue, free of charge. This will take around 2 hours.

The Utility Bodywerks contact information is as follows:

Phone: 574-522-8422 - 8:00 a.m. – 5:00 p.m. EDT
Email: office@utilitybodywerks.com

If Luxe Trucks dba Utility Bodywerks fails or is unable to arrange service as described above without charge, you may submit a complaint to the Administrator, National Highway Traffic Safety Administration, 1200 New Jersey Avenue, S.E., Washington, DC 20590 or call toll-free Auto Safety Hotline at 1-888-327-4236 (TTY 1-800-424-9153); or go to www.safercar.gov.

Commitment to safety, quality and respect for the customer are our highest priorities. Please accept our sincere apology for any inconveniences that may result from modifying the rear brake caliper flexible lines.

Sincerely,

Keith Grupp – General Manager
Luxe Trucks dba Utility Bodywerks