

SAFETY & EMISSION RECALL CAMPAIGN 2A97 2019 & 2020 Burgman 200 Fuel Hose Replacement Recall

Affected Models:	Certain 2019 & 2020 Burgman 200 (UH200AL9-M0) Scooter Models
Affected Departments:	Management, Service, Warranty, Sales, Parts, Accessories
Attachments:	Sales Bulletin 21-093 (Burgman 200 Stop Sales) & Customer Notification Letter
Reference:	Service Bulletins GV/AN/UH No. 056 UH200AL9-M0 Safety Recall Campaign 2A97 & GV/AH/UH No. 055 UH200AL9-M0 Speedometer Recall Campaign 2A96

This notice is sent to you in accordance with the requirements of the National Traffic and Motor Vehicle Safety Act and California Air Resources Board regulations.

Suzuki Motor Corporation has decided that a defect which relates to motor vehicle safety and emissions exists in certain Burgman 200 scooters.

STOP DELIVERY OF AFFECTED VEHICLES IMMEDIATELY

DO NOT SELL OR DELIVER an affected scooter to a customer until you have completed or verified completion of the repair procedures outlined in this bulletin.

It is a violation of Federal law to sell or deliver any new motorcycle, scooter, ATV, or item of motor vehicle equipment subject to a safety recall campaign under a sale or lease until the defect or non-compliance has been corrected.

In addition, selling an unrepaired affected motorcycle, scooter, or ATV is a direct violation of your Suzuki dealer agreement and may lead to additional sanctions.

IMPORTANT NOTICE FOR CALIFORNIA DEALERS

The California Air Resources Board requires that all applicable emission recall campaigns will be completed prior to California registration renewal. If the owner does not have this recall performed, they will not be able to renew their California vehicle registration.

After completing the recall service, your Service Department must give each Burgman 200 owner a "Proof of Correction" certificate. If required, the owner must present this certificate to the Department of Motor Vehicles when renewing their California registration.

What is the defect?

Suzuki Motor Corporation is initiating a safety and emission recall campaign to address potential fuel leakage.

Due to an error in manufacturing the fuel supply line, the inner diameter of the fuel line may be larger than the design specification. Fuel hoses with this condition may have a loose connection with the metal fuel hose attachment pipe. In the worst case, fuel may leak at the connection point with the metal attachment pipe.

What your dealership will do:

- 1) Check your unsold inventory to see if you have any affected Burgman 200 models (use the verification process listed below). If so, order the necessary fuel hose parts, repair the scooter, install a Campaign Completion Sticker inside the trunk and then submit a warranty request to Suzuki Motor USA, LLC (SMO). You must do this before selling or transferring the scooter.
- 2) Check your sales records to contact customers to whom you have sold an affected Burgman 200. Contact the owner of an affected scooter to alert him/her that you are ordering the necessary fuel hose recall repair parts. Let the customer know there will be no charge for parts or labor. Set an appointment to install the parts, perform the recall service, install a Campaign Completion Sticker inside the trunk and then submit a warranty request to SMO.
- 3) If your dealership is contacted by someone who has an affected Burgman 200, but you did not sell the scooter, let the owner know you can assist with the fuel hose recall service. Let the customer know there will be no charge for parts or labor. You can then order the necessary recall repair parts. Set an appointment to install the parts, perform the recall service, install a Campaign Completion Sticker in the trunk, and then submit a warranty request to SMO.

IMPORTANT FOR CALIFORNIA DEALERS ONLY:

In addition to performing the safety and emissions recall repair and installing a Campaign Completion sticker, you must also complete a Vehicle Emission Recall - Proof of Correction certificate and give it to the customer when you deliver the repaired scooter.

- 4) Burgman 200 scooters affected by this fuel hose recall may also be affected by a Speedometer Recall that is described in Service Bulletin GV/AN/UH No. 055 (May 20, 2021). When you perform the fuel hose recall service on a UH200AL9 or UH200AM0, please use the Vehicle Master Inquiry function of Suzuki Connect to determine if the scooter also requires the Speedometer Recall service. If so, order the necessary parts, perform the recall service, and submit a warranty request as described in the bulletin.

Use the VIN & Suzuki Connect to verify if the scooter is affected by the recall:

Before performing the safety and emission recall repair to a unit, first verify the repair needs to be performed by checking the scooter's VIN and accessing the Vehicle Master Inquiry on Suzuki Connect and checking the repair status. If the recall repair needs to be performed, you will see the message "CAMPAIGN NOT YET PERFORMED."

If you have a question regarding scooter eligibility, call TECH LINE at (714) 996-7480 or contact your Suzuki Technical Service & Parts Manager (TSPM).

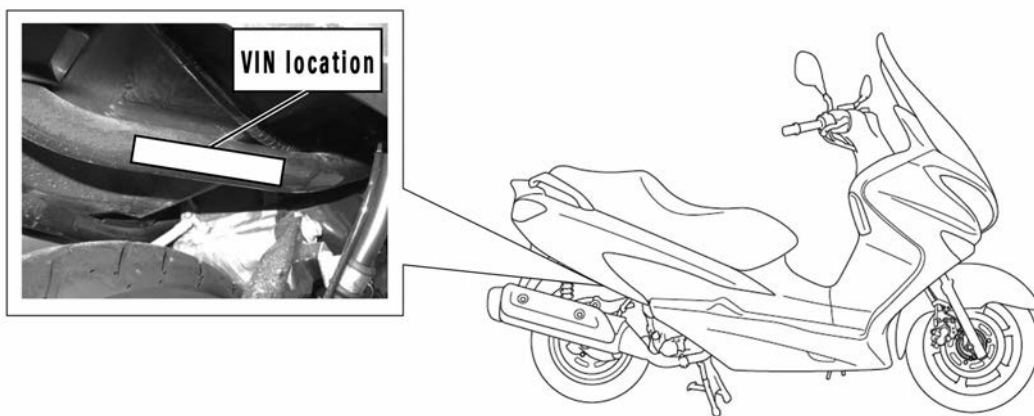

<u>Affected model</u>	<u>Model year</u>	<u>VIN Range</u>
UH200AL9	2019 (L9)	MLCCH41A#K1600001 - MLCCH41A#K1600120
UH200AM0	2020 (M0)	MLCCH41A#L1600001 - MLCCH41A#L1600150

Note: “#” indicates any check digit from 0 to 9 and X.

What Suzuki Motor USA, LLC, will do:

During the week of October 04, 2021, Suzuki Motor USA, LLC (SMO) will mail notifications to owners of affected Burgman 200 scooters for whom we have information. The notice instructs the customer to contact a Suzuki dealer to schedule an appointment for the repair.

If you have sold an affected Burgman 200 to a customer prior to receiving this bulletin, please contact the customer immediately to arrange for the scooter to be returned to your dealership for this safety recall campaign.

Ordering parts for the Safety Recall Campaign:

You will be responsible for ordering parts for this recall using normal parts ordering procedures for each scooter. If you have any questions regarding parts orders, please contact SMO Parts Coordination at (714) 854-2165. Have the VIN available when ordering parts.

Parts ordering information:

Part Name	Part Number	Quantity	Includes
FUEL HOSE SET	15800-29810-RX0	1	Fuel hose (15810-29K10) x 1
			O-ring (15721-26J00) x 1
			Seal ring (15722-21H00) x 1

The Fuel Hose Set also contains a Campaign Completion Sticker ① and a Vehicle Emission Recall - Proof of Correction Certificate ②. See page 10 of this bulletin for sticker and certificate completion requirements.



①

Vehicle Emission Recall - Proof of Correction					
License Number	Make	Model Year	Body Type	Vehicle Identification Number	
Manufacturer _____			Recall Number _____		
The above described vehicle has been repaired, modified and/or equipped with new emission control devices to meet applicable California Emission Control Laws.					
Dealer Name _____		Address, City, State and ZIP _____			
Date _____		Dealership's Authorized Signature _____			
Return this certificate to DMV <u>ONLY</u> when required. Otherwise, retain for your records.					

②

Identification of recall campaign parts (new fuel hose set):

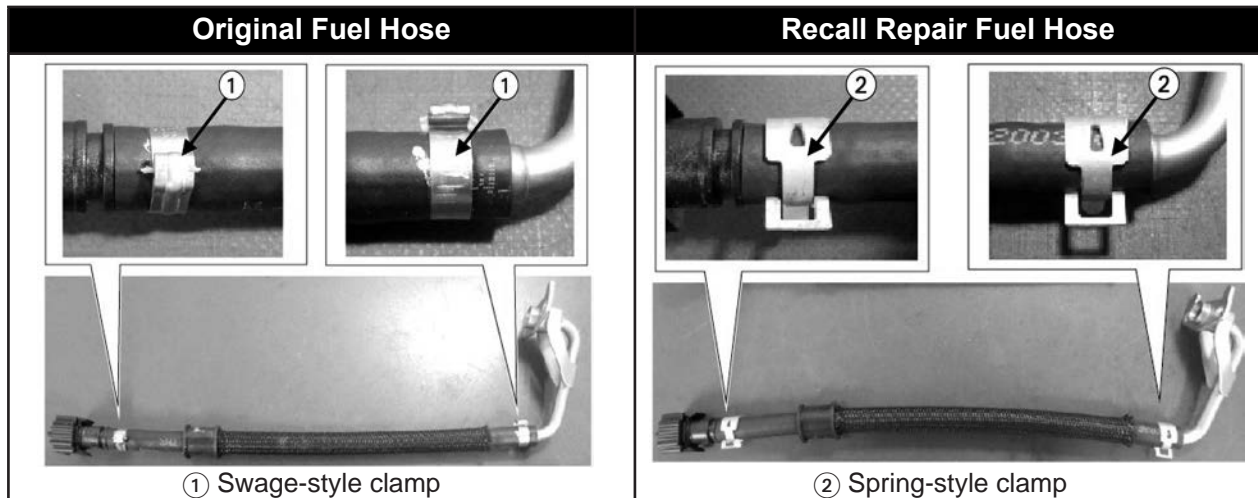

Warranty claim processing:

Submit a warranty claim for each recall repair immediately upon completion. This campaign requires you to file a warranty claim using ONE of the methods described below.

Suzuki Connect Short Campaign Claim: The Short Campaign Claim will reimburse you for the replacement of the fuel hose set and 0.9 hour labor.

CAMPAIGN 2A97 UH200A FUEL HOSE SET SUZUKI CONNECT SHORT FORM INSTRUCTIONS	
CLAIM INFORMATION:	
CLAIM NUMBER:	XXXXX,X (Dealer enters number)
ENTRY TYPE:	VIN, Model/Frame or Control/Sequence # (Dealer chooses)
REPAIR DATE:	Enter date of repair
MILEAGE:	Enter mileage at repair date
CAMPAIGN NUMBER:	2A97
LABOR OPERATION:	DH9999

Suzuki Connect Long Campaign Claim: The Long Campaign Claim will reimburse you for the replacement of the fuel hose set and 0.9 hour labor, and additional parts and labor as authorized by your TSPM.

CAMPAIGN 2A97 UH200A FUEL HOSE SET SUZUKI CONNECT LONG FORM INSTRUCTIONS	
CLAIM INFORMATION:	
CLAIM NUMBER:	XXXXX,X (Dealer enters number)
ENTRY TYPE:	VIN, Model/Frame or Control/Sequence # (Dealer chooses)
REPAIR DATE:	Enter date of repair
MILEAGE:	Enter mileage at repair date
CAMPAIGN NUMBER:	2A97
LABOR TIME:	As authorized by your TSPM
PARTS INFORMATION:	
ADDITIONAL PARTS:	Additional parts as authorized by your TSPM
AUTHORIZATION:	Only needed if additional parts or labor claimed
FAILURE DESCRIPTION:	
DESCRIPTION OF DEFECT:	Fuel hose set replacement
DESCRIPTION OF REPAIR:	Performed service campaign repair per service bulletin

FUEL HOSE SET RECALL SERVICE

- Follow the repair procedure listed on the following pages to replace the original fuel hose with a new Fuel Hose Set that includes a new fuel hose plus a seal ring and O-ring for the fuel injector.

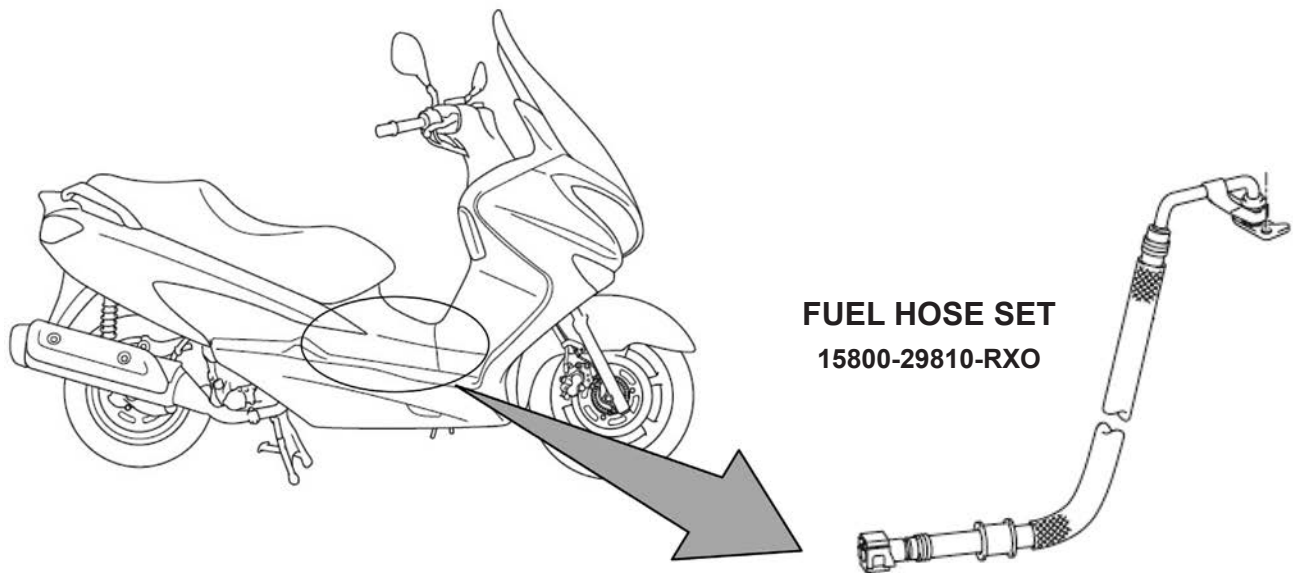

Reminder:

- Check to see if the Burgman 200 you are going to do the fuel hose recall service on is affected by the Speedometer Recall described in Service Bulletin GV/AN/UH No. 055. If the speedometer recall is not done, order the necessary parts, perform the recall service, and submit a warranty request as described in the bulletin.

Precautions:

- To avoid getting burned, do not touch the engine and exhaust system until they have cooled.
- Before the repair work, wash dirt from the scooter to prevent dirt contamination.
- When two or more persons are working together, pay attention to the safety of others.
- When removing parts to be reused, arrange them in an orderly manner so they can be reinstalled in the proper order and orientation.
- Keep away from fire or spark.
- During disassembling, use care to minimize the spilling of gasoline.
- Spilled gasoline should be wiped up immediately.
- Work in a well-ventilated area.
- Refer to the Burgman 200 Service Manual (99500-31523-03E) for any details or procedures not mentioned in these instructions.

Required tools:

- Ratchet tool (3/8 in. drive suggested)
- Extension bar (3/8 in. drive suggested)
- Socket wrench, 10 mm
- Hex-drive socket wrenches, 5 mm & 8 mm
- Phillips screwdriver, #2 tip, medium to long shaft
- Phillips screw driver, #3 tip, medium to long shaft
- Torque wrench, range 5.9 to 15.0 lbf-ft (8.0 - 20.0 N·m, 0.8 - 2.0 kgf-m)

Fuel hose set repair procedure:

Reference: UH200A Service Manual (99500-31527-03E)

1. Remove the right floor mat ①.
2. Remove the battery cover by removing the screws ②.

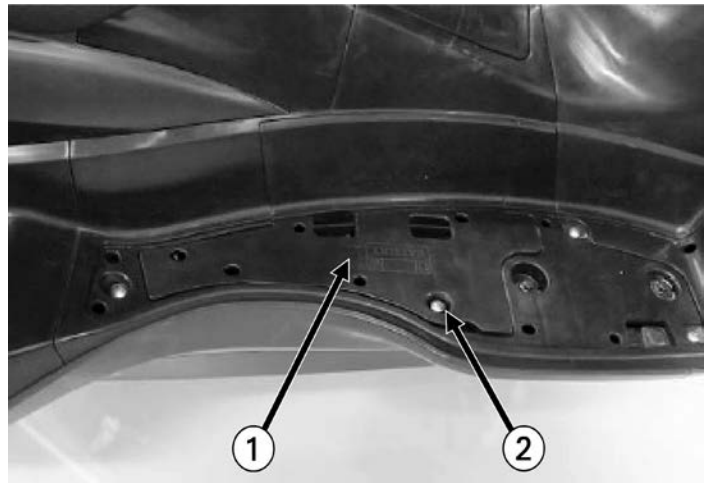

3. Disconnect the battery negative lead wire ③.



4. Remove the following parts:

- Front frame cover (refer to 9D Front Frame Cover Removal and Installation)
- Pillion rider handle (refer to 9D Pillion Rider Handle Removal and Installation)
- Lower frame cover (refer to 9D Lower Frame Cover Removal and Installation)
- Center frame cover (refer to 9D Center Frame Cover Removal and Installation)
- Frame cover (refer to 9D Frame Cover Removal and Installation)
- Trunk box (refer to 9D Trunk Box Removal and Installation)
- EVAP canister (refer to 9D EVAP Canister Removal and Installation - if equipped)

5. Disconnect the fuel injector coupler ④.
6. Place an absorbent cloth under the fuel hose ⑤ and disconnect the fuel hose from the fuel injector ⑥ by removing the two 6mm bolts ⑦ with a 5mm hex tool.
7. Remove the cloth that was placed under the fuel hose.

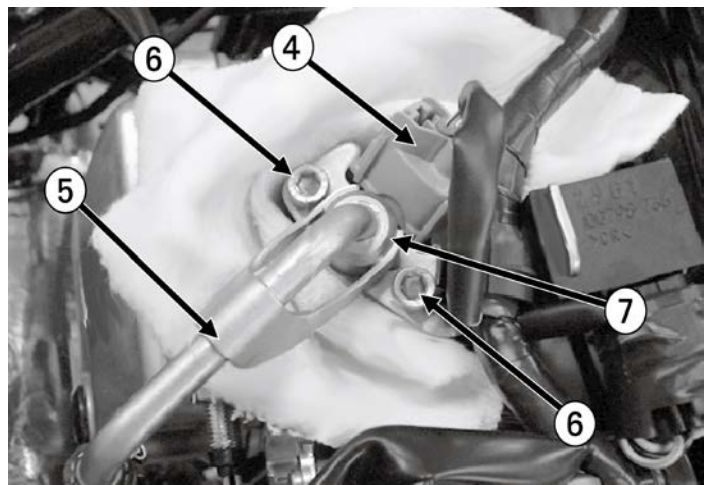

8. Unlock the fuel hose joint ④ by pulling the retainer ① outward.

NOTE:

Place an absorbent cloth under the fuel hose joint ④ to collect any gasoline that may come out of the hose.

9. Press the buttons ② on both sides of the fuel hose joint ④ and pull the fuel hose so it disconnects from the fuel pump ③.

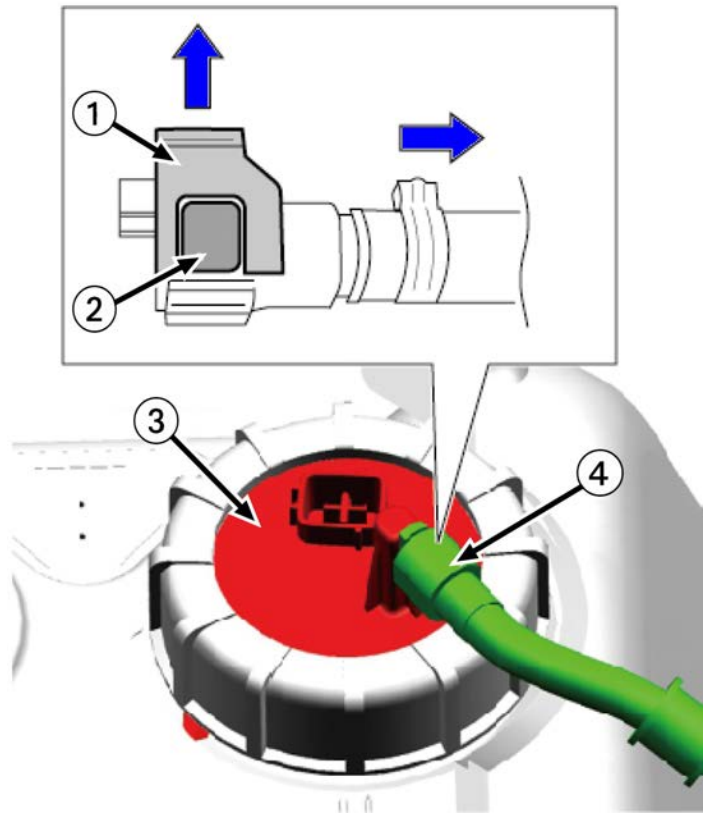

10. Remove the fuel injector ⑤ by pulling it upward (as shown in the illustration) from the intake pipe ⑥.

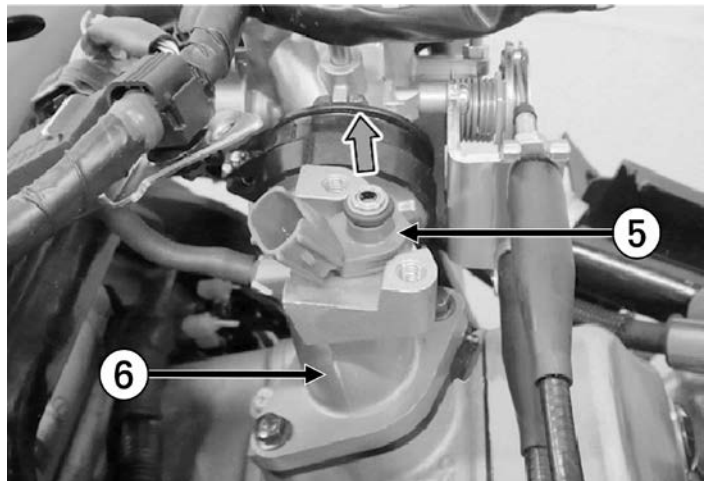

11. Remove the seal ring ⑦ and the O-ring ⑧ from the fuel injector ⑨.

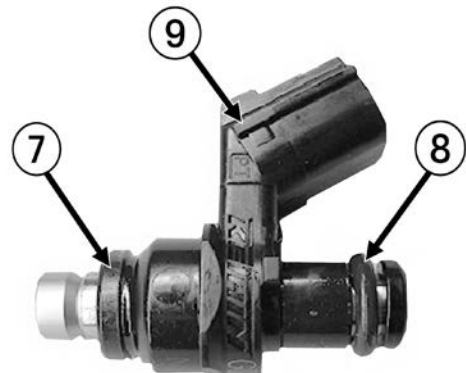

Installation:

1. Install the new seal ring ① and new O-ring ② to the fuel injector ③. Apply a thin coat of clean engine oil to the seal ring and O-ring.

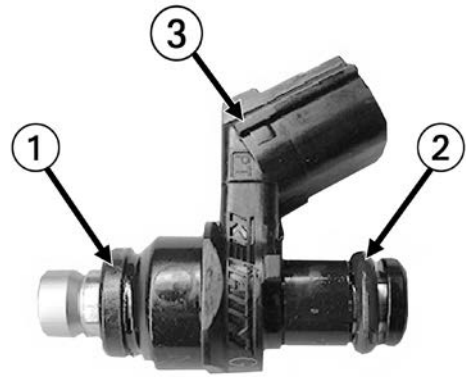

2. Install the fuel injector ④ by pushing it straight down into the intake pipe ⑤ (as shown in the illustration).

NOTE:

Never turn the fuel injector while pushing it into the intake pipe. Damage to the injector, the seal ring, or the O-ring may occur.

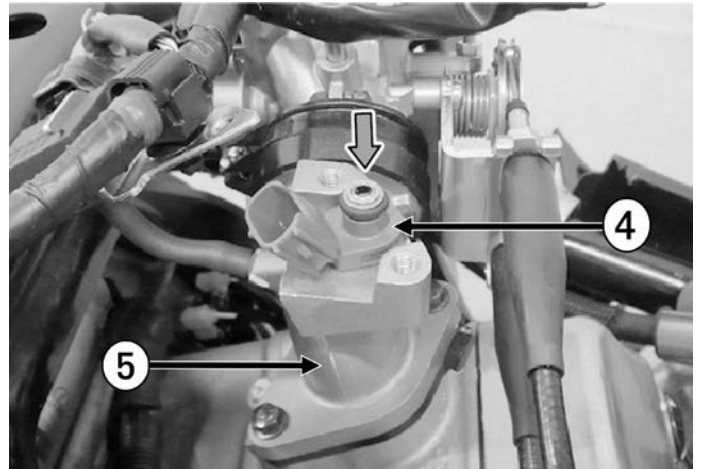

3. Install the new fuel hose ⑥ to the fuel injector ⑦ and tighten the bolts ⑧ to the specified torque.

Tightening torque:

Bolt ⑧: 7.5 lbf-ft (10.N.m, 10 kgf-m)

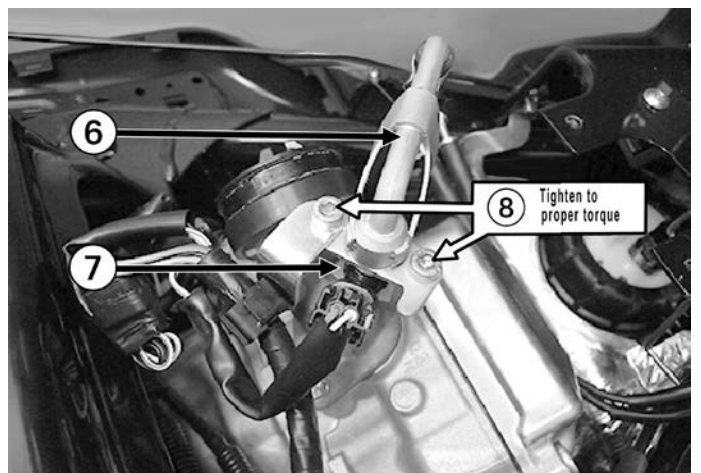

4. Pull the retainer ① out from the fuel hose joint ②.

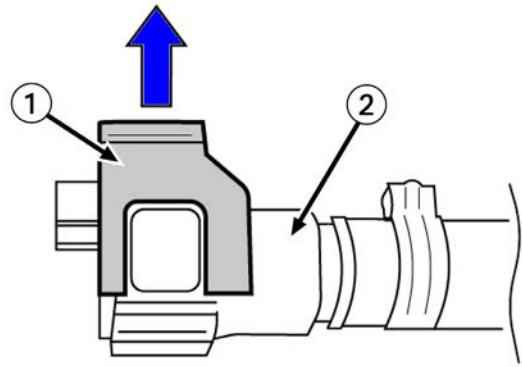

5. Connect the fuel hose joint ② to the fuel pump ③.
6. Lock the fuel hose joint by pushing in the retainer ①.
7. Pull on the fuel hose by hand to confirm that the fuel hose joint ② is securely attached to the fuel pump ③.

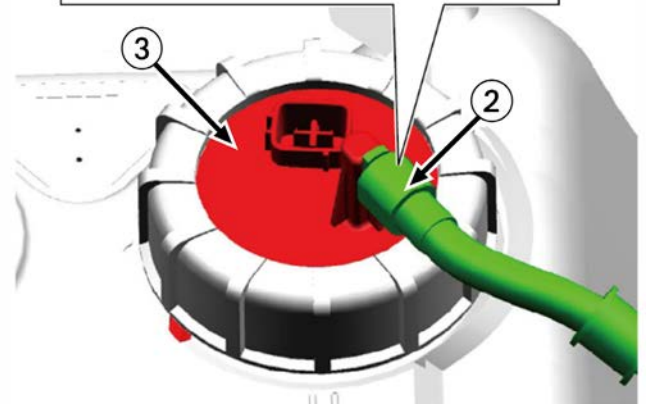
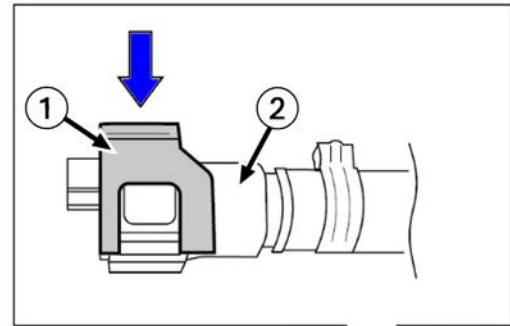

8. Install the following parts:
- EVAP canister (refer to 9D EVAP Canister Removal and Installation - if equipped)
 - Trunk box (refer to 9D Trunk Box Removal and Installation)
 - Frame cover (refer to 9D Frame Cover Removal and Installation)
 - Lower frame cover (refer to 9D Lower Frame Cover Removal and Installation)
 - Center frame cover (refer to 9D Center Frame Cover Removal and Installation)
 - Pillion rider handle (refer to 9D Pillion Rider Handle Removal and Installation)
- **Tightening torque - Pillion rider handle bolt (a): 15.0 lbf-ft (20 N·m, 2.0 kgf-m)**
 - Front frame cover (refer to 9D Front Frame Cover Removal and Installation)

8. Connect the battery negative (-) lead wire ④.
9. Install the battery cover.
10. Install the right floor mat.

11. Completion - perform the following quality checks:
- Check that each part is installed properly and tightened securely (refer to Service Manual)
 - Set the time on the clock (refer to Owner's Manual)



Repair Completion Sticker Installation:

MUST BE COMPLETED BY ALL DEALERS

Write your six-digit Suzuki dealer number on the bottom half of the Repair Completion Sticker using a permanent marker of pen with black in (for example, a Sharpie® brand marker with a fine point). Then apply the sticker to the inside of the under-seat trunk as shown below.



Attach the Repair Completion Sticker as shown.

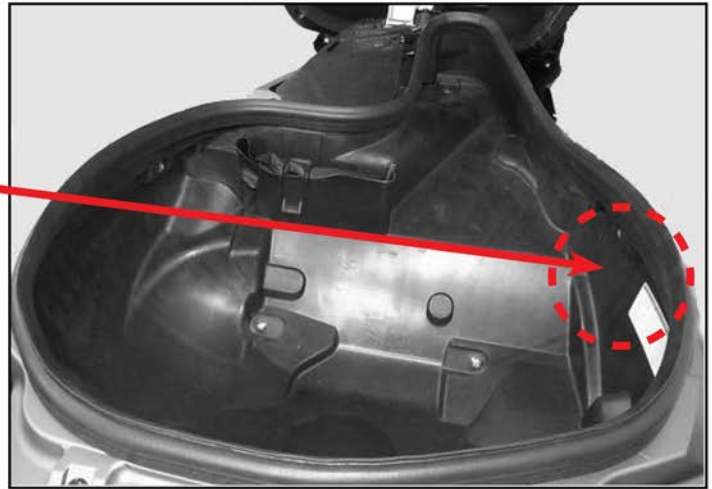

MUST BE COMPLETED BY CALIFORNIA DEALERS

In addition to attaching a Repair Completion Sticker to the inside of the trunk:

1. Complete a Vehicle Emission Recall - Proof of Correction certificate (example below) and give it your customer when you deliver the repaired scooter.
2. Explain to your customer that it is important for them to save this certificate as they may need to provide it to the California Department of Motor Vehicles when renewing their Burgman 200 (UH200A) registration.

If your dealership needs more of Repair Completion stickers and/or Proof of Correction certificates, contact TECH LINE (at 714-996-7480) or your Technical Service & Parts Manager (TSPM).

Vehicle Emission Recall - Proof of Correction					
License Number	Make	Model Year	Body Type	Vehicle Identification Number	
Manufacturer _____			Recall Number _____		
The above described vehicle has been repaired, modified and/or equipped with new emission control devices to meet applicable California Emission Control Laws.					
Dealer Name _____		Address, City, State and ZIP _____			
Date _____		Dealership's Authorized Signature _____			
Return this certificate to DMV ONLY when required. Otherwise, retain for your records.					

SALES



Bulletin No. 21-093

Date: July 21, 2021

IMPORTANT SAFETY RECALL
STOP RETAIL SALES and DELIVERY

Suzuki Motor Corporation has determined that a safety defect exists in certain 2019 & 2020 Burgman 200 (UH200AL9/M0) models:

Model	VIN	VIN
UH200AL9	MLCCH41A9K1600035	
UH200AM0	MLCCH41A9L1600005	MLCCH41A4L1600039
	MLCCH41A8L1600058	MLCCH41A6L1600060
	MLCCH41A0L1600135	

Suzuki Motor Corporation is initiating a safety recall campaign to address potential fuel leakage. Due to an error in manufacturing the fuel supply line, the inner diameter of the fuel line may be larger than the design specification. Fuel hoses with this condition may have a loose connection with the metal fuel hose attachment pipe. In the worst case, fuel may leak at the connection point with the metal attachment pipe.

Technical Service Bulletin:

Initial Service information regarding this safety recall will be provided in a Technical Service Bulletin the week of August 13, 2021.

Parts Availability:

Suzuki Motor USA, LLC (“SMO”) will provide additional information regarding parts availability in a Technical Service Bulletin referenced above.

Customer Notification:

SMO expects to notify retail customers of this safety recall by the week of August 20, 2021.

Speedometer Recall Reminder:

Burgman 200 scooters affected by this fuel hose recall may also be affected by a Speedometer Recall that is described in [Service Bulletin GV/AN/UH No. 055 \(May 20, 2021\)](#). When you perform the fuel hose recall service on a UH200AL9 or UH200AM0, please use the Vehicle History function of Suzuki Connect to determine if the scooter also requires the Speedometer Recall service. If so, order the necessary parts, perform the recall service, and submit a warranty request as described in the bulletin.

Bulletin No. **21-093**

Date: **July 21, 2021**

Consequences of Non-Compliance:

ALL NEW SUZUKI VEHICLES IN DEALER INVENTORY THAT ARE SUBJECT TO A RECALL OR CUSTOMER SATISFACTION CAMPAIGN INITIATED BY SMO MUST BE REPAIRED BEFORE THESE VEHICLES ARE SOLD OR DELIVERED BY THE DEALER TO THE RETAIL CUSTOMER. FAILURE TO DO SO IS A VIOLATION OF FEDERAL LAW, THE SUZUKI POWERSPORTS DEALER SALES AND SERVICE AGREEMENT (THE "DEALER AGREEMENT"), AND SMO'S SALES POLICY REGARDING FACTORY SAFETY RECALL OR SAFETY MODIFICATION PROGRAMS (THE "POLICY"). A COPY OF THE POLICY IS AVAILABLE ON SUZUKI CONNECT FOR YOUR REFERENCE.

FURTHER, FAILURE TO COMPLY WITH THE INSTRUCTIONS OF SMO REGARDING COMPLIANCE WITH RECALLS OR OTHER SAFETY OR PRODUCT IMPROVEMENT CAMPAIGNS OR PROGRAMS, AND/OR FAILURE TO MAKE A GOOD FAITH EFFORT TO COMPLY WITH THE FEDERAL CLEAN AIR ACT, THE NATIONAL TRAFFIC AND MOTOR VEHICLE SAFETY ACT, THE CONSUMER PRODUCT SAFETY ACT, OR ANY OTHER LAWS, ORDERS, RULES, OR REGULATIONS REGARDING RECALLS OR OTHER SAFETY OR PRODUCT IMPROVEMENT CAMPAIGNS OR PROGRAMS CONSTITUTES A BREACH OF THE DEALER AGREEMENT AND IS A VIOLATION OF SMO POLICY REFERENCED ABOVE. A DEALER MAY BE HELD RESPONSIBLE FOR ANY PRODUCT DAMAGE AND/OR PERSONAL INJURIES RESULTING FROM SUCH FAILURE.

If you need any additional information, please contact the Suzuki TECH LINE (at 714-996-7480) or your Technical Service and Parts Manager (TSPM). We apologize for this inconvenience and will do everything possible to resolve this situation as quickly as possible.

Thank you for your continued support and understanding.



Chris Coons
Senior Manager, Motorcycle Sales Planning and Administration



IMPORTANT SAFETY & EMISSIONS RECALL

This Notice Applies to Your Suzuki Vehicle Identification Number (VIN)

October 04, 2021

Dear Suzuki Owner:

In August 2021 you should have received a notice announcing that Suzuki Motor Corporation decided to conduct a Safety Recall for certain 2019 and 2020 Suzuki Burgman scooters.

This notice is sent to you in accordance with California Air Resources Board (CARB) regulations. Suzuki Motor Corporation has decided to make this a Safety and Emissions Recall.

Suzuki Motor Corporation has decided that a defect which relates to motor vehicle safety and emissions exists in certain Burgman 200 scooters. According to our records, you own one of the scooters affected by this recall campaign.

What is the defect and what will your dealership do to correct it?

Suzuki Motor Corporation is initiating a safety and emission recall campaign of 2019 & 2020 Burgman 200 scooters to address potential fuel leakage.

Due to an error in manufacturing the fuel supply line, the inner diameter of the fuel line may be larger than the design specification. Fuel hoses with this condition may have a loose connection with the metal fuel hose attachment pipe. Fuel may leak at the connection point with the metal attachment pipe.

Your Suzuki dealer will verify if your scooter requires the emissions recall service and install an updated Fuel Hose Set. This emissions recall service will take approximately one hour to complete.

Parts are available now, and there will be no charge to you for any recall service-related parts or labor.

⚠ WARNING

Operating your scooter without having the recall service performed increases the risk of a fire.

To minimize the risk of a fire:

- Please do not ride nor allow anyone else to ride your scooter until this recall service has been completed.
- If you must ride your scooter before this safety recall service has been completed, check for fuel leakage and other items for proper operation as outlined in the "INSPECTION BEFORE RIDING" checklist in section 4 of your owner's manual before each ride.

IMPORTANT NOTICE FOR CALIFORNIA RESIDENTS

The California Air Resources Board requires that all applicable emission recall campaigns be completed prior to California registration renewal. If you do not have this recall campaign performed, you will not be able to renew your California vehicle registration.

After completing the recall service, your California Suzuki dealer will give you a "Proof of Correction" certificate. If required, present the original of this certificate to the Department of Motor Vehicles when renewing your California registration and keep a copy for your records.

What you should do:

Make sure you are prepared for the recall service by taking the following steps:

- Contact your Suzuki dealer as soon as possible to make an appointment for the recall service. Be prepared to provide them with the VIN of your scooter (provided at the top of this notice).
- Please take this notice to your Suzuki dealer to help your dealer process your claim.

CUSTOMER NOTIFICATION LETTER (page 2 of 2)

- If your Burgman 200 has already received a Fuel Hose Set Safety Recall Service, please contact your Suzuki dealer to discuss the emissions recall service and the related documentation you will need to have for future vehicle registration.

What to do if you receive this notice in error:

This notice was mailed to you according to the latest information that is available to us. If you no longer own the Suzuki scooter described in this notice, please complete, and return the attached Change of Address/Ownership card to Suzuki Motor USA, LLC, and forward this recall information to the current owner (if known).

Federal regulations require that any vehicle lessor receiving this recall notice must forward a copy of this notice to the lessee within ten days.

Emission Warranty Provision

To ensure your full protection under the emission warranty provisions, it is recommended that you have your scooter serviced as soon as possible. Failure to do so could be determined as lack of proper maintenance of your vehicle. Eligibility for the recall service will not be denied solely because you installed non-Suzuki parts or had repairs performed by someone other than an authorized Suzuki dealer.

Customer reimbursement for repairs prior to this Emission Recall Notification:

If your scooter is included in this recall and you have paid for repairs to address the defect that led to this recall, you may be eligible for full or partial reimbursement. Please note the following conditions for reimbursement:

- Only repairs made to address the defect that led to this recall are reimbursable. Additional expenses such as towing, car rental, accommodations, damage repairs, etc., will not be reimbursed. Reimbursement will not be provided for routine scheduled maintenance.
- Reimbursement may be limited to the suggested list price for parts, the Suzuki published flat-rate time allowance for the repair, and the labor rate that an authorized Suzuki Service Provider in the same area would charge for the same repair.
- Reimbursement claims may also be excluded when adequate documentation is not submitted by the claimant. This includes a proof of ownership, a repair order, and proof of payment for the repair.

To apply for reimbursement, contact the Suzuki Motor USA, LLC Customer Service Department at (714) 572-1490 during the hours of 7:30 AM to 4:30 PM Pacific Time.

Who to contact if you experience problems:

Your Suzuki dealer can provide you the fastest response to your questions or concerns about this emissions recall campaign. If you have any difficulty with this recall campaign, you may contact the Suzuki Motor USA, LLC, Customer Service Department for assistance at (714) 572-1490 during the hours of 7:30 AM to 4:30 PM Pacific Time. Please have your vehicle identification number (VIN) ready when calling.

If you need to locate your nearest Suzuki Motorcycle Dealer, please visit www.suzukicycles.com and click on the "FIND A DEALER" tab, which is in the upper right corner of our website.

If you believe that Suzuki Motor USA, LLC, has failed to provide the safety recall campaign service without charge or is unable to do so within a reasonable time, you may submit a complaint to the Administrator of the National Highway Traffic Safety Administration, 1200 New Jersey Ave., S.E., Washington D.C., 20590 or call the toll-free Vehicle Safety Hotline at 1-888-327-4236 (TTY: 1-888-424-9153) or go to www.safercar.gov.

We apologize for any inconvenience this recall campaign causes you. We hope you understand that your safety and satisfaction are important priorities for us.

Sincerely,

Suzuki Motor USA, LLC