

# SERVICE BULLETIN



UTILITY TRAILER MANUFACTURING CO.

## SB-07-015

April 7, 2021

### Super Doubles Trailers | Trailers Manufactured out of Glade Springs, VA between Jan 2006 to May 2021

**RECALL NOTICE:** Trailers manufactured out of Glade Springs, VA factory for Super Doubles operation may be missing a horizontal weld attaching a mild steel angle to the slider rail just above the pintle hook tube assembly.

Inspect if weld is present. Weld can be located on the INSIDE (between the slider rails) or OUTSIDE. If weld is not present, ok to apply  $\frac{1}{4}$ " weld full length as shown to OUTSIDE mating surface of mild steel angle to slider rail.

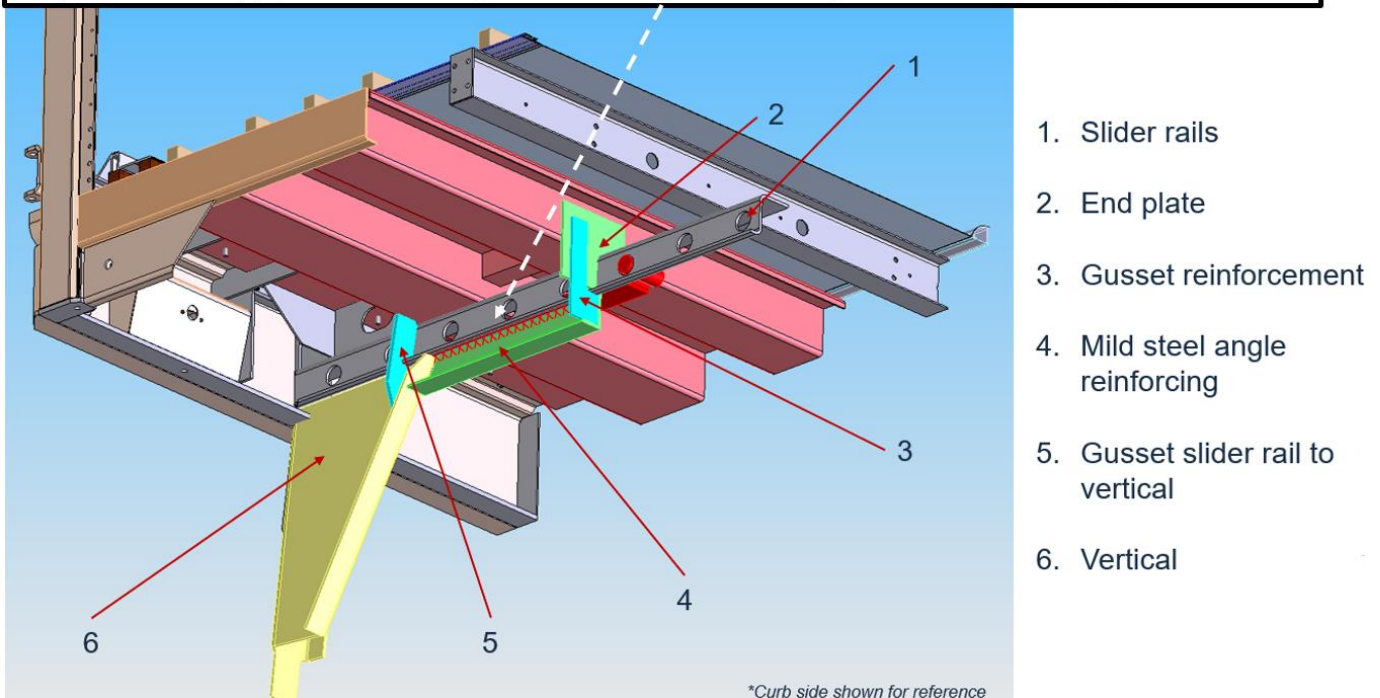

Customers and lessees can schedule with local Utility Service for inspection and adding the weld. File recall claims with Utility Field Service for reimbursement of labor time and weld materials (inspection .25hrs + adding weld 2hrs).

Any further questions should be directed to Utility's Field Service Department at 1(800) 423-6591.

**Field Service Department**  
**UTILITY TRAILER MANUFACTURING COMPANY**