



David J. Johnson
 Director
 Service Engineering Operations
 Ford Customer Service Division

Ford Motor Company
 P. O. Box 1904
 Dearborn, Michigan 48121

June 3, 2021

TO: All U.S. Ford and Lincoln Dealers

SUBJECT: **NEW VEHICLE DEMONSTRATION / DELIVERY HOLD**
Compliance Recall 21C06 – Supplement #1
 Certain 2020 - 2021 Model Year F-150 and Super Duty Vehicles
 Windshield Glass Reattachment

REF: **Compliance Recall 21C06**
 Certain 2020 - 2021 Model Year F-150 and Super Duty Vehicles
 Dated: April 7, 2021

New! REASON FOR THIS SUPPLEMENT

- **Sublet Repairs:** Dealers will now be able to claim either labor operation 21C06D or have a \$250 allowance for windshield removal and installation.
- **Labor Allowances:** Updated to reflect the optional IPMA camera and 21C06D sublet option.
- **Attachment III:** Minor changes for clarification on procedures.
- **Attachment IV:** Updated the instructions to include a note about protecting the body near the top of the windshield and minor changes for clarification on procedures.

AFFECTED VEHICLES

Vehicle	Model Year	Assembly Plant	Build Dates
Super Duty	2020 – 2021	Kentucky Truck	October 13, 2020 through January 23, 2021
F-150	2021	Dearborn	October 27, 2020 through February 3, 2021

Affected vehicles are identified in OASIS and FSA VIN Lists.

REASON FOR THIS COMPLIANCE RECALL

All of the affected vehicles may not conform to the requirements specified by Federal Motor Vehicle Safety Standard (FMVSS) 212 Windshield Mounting, some vehicles may have a bonding concern between the clearcoat and windshield urethane or the primer coat and the basecoat. This bonding concern could allow the windshield to lose adhesion to the vehicle body in the event of an accident, which may increase the risk of injury to an occupant.

SERVICE ACTION

Before demonstrating or delivering any new in-stock vehicles involved in this recall, dealers are to remove the windshield and improve the windshield urethane to body adhesion using the attached procedure. This service must be performed on all affected vehicles at no charge to the vehicle owner.

OWNER NOTIFICATION MAILING SCHEDULE

Owner letters were mailed the week of April 19, 2021. Dealers should repair any affected vehicles that arrive at their dealerships, whether or not the customer has received a letter.

PLEASE NOTE:

Federal law requires dealers to complete this recall service before a new vehicle is delivered to the buyer or lessee. Violation of this requirement by a dealer could result in a civil penalty of up to \$21,000 per vehicle. Correct all vehicles in your new vehicle inventory before delivery.

New! ATTACHMENTS

Attachment I: Administrative Information
Attachment II: Labor Allowances and Parts Ordering Information
Attachment III: Technical Information – Body Shop
Attachment IV: Technical Information – Glass Company

Owner Notification Letters

QUESTIONS & ASSISTANCE

For questions and assistance, contact the Special Service Support Center (SSSC) via the SSSC Web Contact Site. The SSSC Web Contact Site can be accessed through the Professional Technician System (PTS) website using the SSSC link listed at the bottom of the OASIS VIN report screen or listed under the SSSC tab.

Sincerely,



David J. Johnson

**NEW VEHICLE DEMONSTRATION / DELIVERY HOLD -
Compliance Recall 21C06 – *Supplement #1***
Certain 2020 - 2021 Model Year F-150 and Super Duty Vehicles
Windshield Glass Reattachment

OASIS ACTIVATION

OASIS was activated on April 7, 2021.

FSA VIN LISTS ACTIVATION

FSA VIN Lists have been available through <https://web.fsavinlists.dealerconnection.com> since April 7, 2021. Owner names and addresses have been available since May 4, 2021.

NOTE: Your FSA VIN Lists may contain owner names and addresses obtained from motor vehicle registration records. The use of such motor vehicle registration data for any purpose other than in connection with this recall is a violation of law in several states, provinces, and countries. Accordingly, you must limit the use of this listing to the follow-up necessary to complete this recall.

SOLD VEHICLES

- Ford has not issued instructions to stop selling/delivering or driving used vehicles under this compliance recall. Owners should contact their dealer for an appointment to have their vehicles remedied as soon as practicable. Owners can continue to safely drive their vehicles.
- Immediately contact any of your affected customers whose vehicles are not on your VIN list but are identified in OASIS. Give the customer a copy of the Owner Notification Letter (when available) and schedule a service date.
- Correct other affected vehicles identified in OASIS which are brought to your dealership.
- Dealers are to prioritize repairs of customer vehicles over repairs of new and used vehicle inventory.

STOCK VEHICLES

- Correct all affected units in your new vehicle inventory before delivery.
- Use OASIS to identify any affected vehicles in your used vehicle inventory.

DEALER-OPERATED RENTAL VEHICLES

The Fixing America's Surface Transportation (FAST) Act law effective June 2016 prohibits a rental company from selling, renting or leasing vehicles subject to a safety or compliance recall. Please consult your legal counsel for legal advice.

TITLE BRANDED / SALVAGED VEHICLES

Affected title branded and salvaged vehicles are eligible for this recall.

OWNER REFUNDS

Refunds are not approved for this program.

**NEW VEHICLE DEMONSTRATION / DELIVERY HOLD -
Compliance Recall 21C06 – *Supplement #1***
Certain 2020 - 2021 Model Year F-150 and Super Duty Vehicles
Windshield Glass Reattachment

RENTAL VEHICLES

Dealers are pre-approved for up to 1 days for a rental vehicle. Follow Extended Service Plan (ESP) guidelines for dollar amounts. Rentals will only be reimbursed for the day(s) the vehicle is at the dealership for part replacement. Prior approval for more than 1 rental day(s) is required from the SSSC. Contact the SSSC via the SSSC Web Contact Site for consideration and approval if appropriate.

ADDITIONAL REPAIR (LABOR TIME AND/OR PARTS)

Additional repairs identified as necessary to complete the FSA should be managed as follows:

- For related damage and access time requirements, refer to the Warranty and Policy Manual / Section 6 – Ford & Lincoln Program Policies / General Information & Special Circumstances for FSA's / Related Damage.
- For vehicles within new vehicle bumper-to-bumper warranty coverage, no SSSC approval is required, although related damage must be on a separate repair line with the "Related Damage" radio button checked.
 - Ford vehicles – 3 years or 36,000 miles
- For vehicles outside new vehicle bumper-to-bumper warranty coverage, submit an Approval Request to the SSSC Web Contact Site prior to completing the repair.

New! CLAIMS PREPARATION AND SUBMISSION

- **Claim Entry:** Enter claims using Dealer Management System (DMS) or One Warranty Solution (OWS) online.
 - When entering claims, select claim type 31: Field Service Action. The FSA number 21C06 is the sub code.
 - For additional claims preparation and submission information, refer to the Recall and Customer Satisfaction Program (CSP) Repairs in the OWS User Guide.
- **Related Damage/Additional labor and/or parts:** Must be claimed as Related Damage on a separate repair line from the FSA with same claim type and sub code as described in Claim Entry above.

IMPORTANT: Click the Related Damage Indicator radio button.

- **Rentals:** For rental vehicle claiming, follow Extended Service Plan (ESP) guidelines for dollar amounts. Enter the total amount of the rental expense under Miscellaneous Expense code RENTAL.
- ***Sublet Glass Removal/Installation:*** *Sublet repairs to remove and install the windshield can be claimed instead of 21C06D. Sublet documentation must be retained. Submit on the same line as the repair.*

- Program Code: 21C06

- Misc. Expense: FSAOSL

- Misc. Expense: Claim up to \$250

NEW VEHICLE DEMONSTRATION / DELIVERY HOLD -
Compliance Recall 21C06 – *Supplement #1*
Certain 2020 - 2021 Model Year F-150 and Super Duty Vehicles
Windshield Glass Reattachment

- **Provision for Locally Obtained Supplies:** Cleaning supplies, consumables, and either Dow® or Sika® brand automotive glass bonding materials. Submit on the same line as the repair.
 - Program Code: 21C06
 - Misc. Expense: OTHER
 - Misc. Expense: Claim up to \$100

**NEW VEHICLE DEMONSTRATION / DELIVERY HOLD -
Compliance Recall 21C06 – *Supplement #1***
Certain 2020 - 2021 Model Year F-150 and Super Duty Vehicles
Windshield Glass Reattachment

New! LABOR ALLOWANCES

Note: Due to the complexity of this repair, the labor operations have been split into multiple operations to better allow easier allocation within the different dealership departments.

Description	Labor Operation	Labor Time
Prep Front Window flange – Cannot be claimed with 21C06C	21C06B	0.4 Hours
Prep Front Window flange - Lead Foot Gray Only – Cannot be claimed with 21C06B	21C06C	1.2 Hours
Remove and Install Front Windshield (Includes Cowl and A-Pillar R&I) – Cannot be claimed with Sublet Glass Removal/Installation Provision	21C06D	1.3 Hours
IPMA camera alignment – If equipped	21C06E	0.3 Hours
Clean Vehicle	MT21C06	Up to 0.5 Hours

PARTS REQUIREMENTS / ORDERING INFORMATION

Part Number	Description	Order Quantity	Claim Quantity
Consumables Required for all Vehicles			
Obtain Locally	Masking Tape	Claim as MISC OTHER	
	Glass Cleaner		
	Dow BETAPRIME 5504G / Sika Primer-207 or equivalent		
	SikaTack MACH 60 / SikaTack MACH 30 / Dow BETASEAL Express / Sika Tack ASAP Urethane Adhesive or equivalent		
	Roloc Disks or equivalent		
	Isopropyl Alcohol		
	Ford Approved Epoxy Based Primer		
Super Duty Windshield Part Numbers			
LC3Z-2503100-C	Windshield	VIN Specific	
LC3Z-2503100-D	Windshield	VIN Specific	
JL3Z-1503100-F	Windshield	VIN Specific	
MC3Z-2503100-A	Windshield	VIN Specific	

**NEW VEHICLE DEMONSTRATION / DELIVERY HOLD -
Compliance Recall 21C06 – *Supplement #1***
Certain 2020 - 2021 Model Year F-150 and Super Duty Vehicles
Windshield Glass Reattachment

F-150 Windshield Part Numbers		
ML3Z-1503100-A	Windshield	VIN Specific
ML3Z-1503100-B	Windshield	VIN Specific
ML3Z-1503100-D	Windshield	VIN Specific

Order your parts through normal order processing channels. To guarantee the shortest delivery time, an emergency order for parts must be placed.

Note: Less than 20% of the affected vehicle population is expected to require windshield replacement.

DEALER PRICE

For latest prices, refer to DOES II.

PARTS RETENTION, RETURN, & SCRAPPING

Follow the provisions of the Warranty and Policy Manual, Section 1 - WARRANTY PARTS RETENTION AND RETURN POLICIES. If a replaced part receives a scrap disposition, the part must be scrapped in accordance with all applicable local, state and federal environmental protection and hazardous material regulations. Federal law prohibits selling motor vehicle parts or components that are under safety, compliance, or emissions recall.

EXCESS STOCK RETURN

Excess stock returned for credit must have been purchased from Ford Customer Service Division in accordance with Policy Procedure Bulletin 4000.

REPLACED FSA PARTS INSPECTION AND SIGN OFF

Effective March 1st 2021 all parts replaced as part of an FSA repair with a repair order open date of March 1st 2021 or later must be inspected and signed off on the repair order by a member of your dealers fixed operations management team or an employee the task has been delegated to. If the task is to be delegated to a non-management employee, the employee needs to be someone other than the technician who completed the repair and needs to understand the importance of completing this task consistently and accurately.

- All parts replaced as part of an FSA repair should be returned to the parts department following the Warranty Parts Retention and Return Policies.
- Inspect the replaced parts to verify the FSA repair was completed.
- If the FSA repair is found to be complete, the designated employee signs the repair order line or parts return stamp area (electronic or hand signed) for the FSA repair indicating the parts were inspected and validated to have been replaced.
- After the parts have been inspected, they should be handled based on the guidance in the parts status report in the Online Warranty System (Hold, Return, CORE, Scrap, etc.).

**NEW VEHICLE DEMONSTRATION / DELIVERY HOLD -
Compliance Recall 21C06 – *Supplement #1***
Certain 2020 - 2021 Model Year F-150 and Super Duty Vehicles
Windshield Glass Reattachment

- This process is subject to review during warranty audits for FSA repairs with a repair order open date of March 1st 2021 or later. Any eligible FSA claims requiring parts replacement, found not to have been inspected and signed off during a warranty audit will be subject to chargeback and consideration for enrollment into the Dealer Incomplete Recall Repair Process.

Note: Other approvals (electronic or handwritten) for add-on repair lines, dealer owned vehicle repairs, and repeat repairs do not qualify as FSA parts inspection approvals. The post repair FSA parts inspection process (electronic or handwritten) is independent from other warranty approval requirements. The approval by the designated employee implies that the FSA parts were found to be replaced and must be able to be clearly identified on the Repair Order. If multiple FSA's require approval on a single Repair Order, each applicable occurrence will require individual post repair approval by the designated employee.

CERTAIN 2021 MODEL YEAR F-150 and 2020-2021 MODEL YEAR SUPER DUTY VEHICLES — WINDSHIELD GLASS REATTACHMENT

SERVICE PROCEDURE

NOTE: These instructions are not intended to be followed from beginning to end. There are several locations where procedures must be completed by other groups before the procedure in these instructions can be resumed.

The instructions should be followed in this order.

1. Glass Company – Remove windshield – Steps 1-27 as required.
2. Body Shop – Improve Flange adhesion – Steps 1-10 as required.
3. Glass Company – Install windshield – Steps 28-36
4. Body Shop – Calibrate Image Processing Module A – Step 11

BODY SHOP - PART ONE

1. Cover/protect the body and interior of the vehicle.
2. Is the vehicle Lead Foot Gray?
Yes – Proceed to Step 3.
No – Proceed to Steps 4-6.
3. Using a Scotch-Brite 3M Roloc disk, remove all the urethane, clear coat, base coat, and paint primer only where the urethane will be applied around the entire *windshield body* flange perimeter. The goal is to expose the e-coat without going down to bare metal. See Figure 1.

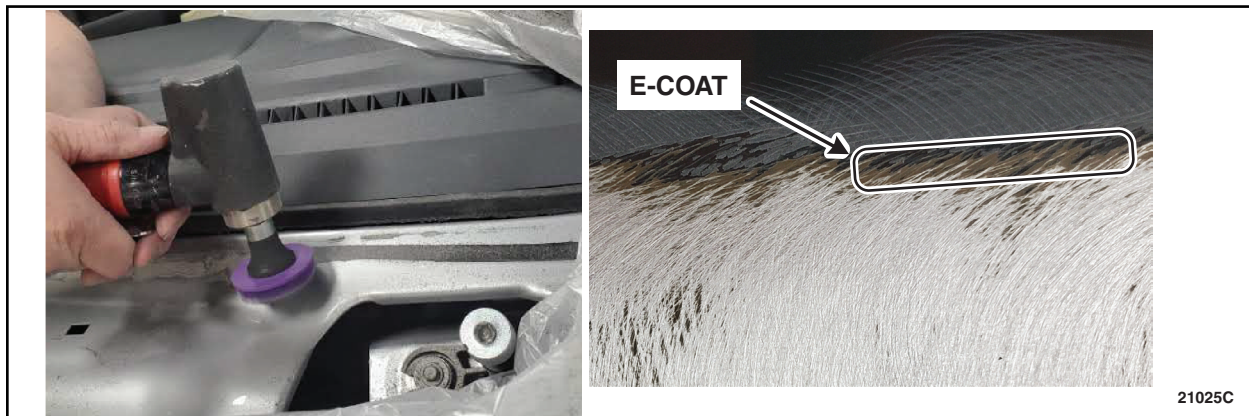

FIGURE 1

4. Using a scraper, cut the urethane vertically across the urethane bead down to the painted surface. Once reaching the painted surface, pry one side of the bead up with the scraper. Using fingers, work to peel the urethane off the windshield *body* flange.



- In areas where the urethane peeled up cleanly, use **400-600 grit** sandpaper or a **fine** Scotch-Brite pad to manually scuff clear coat lightly until it displays a white haze being sure to only abrade the flange. See Figure 2.

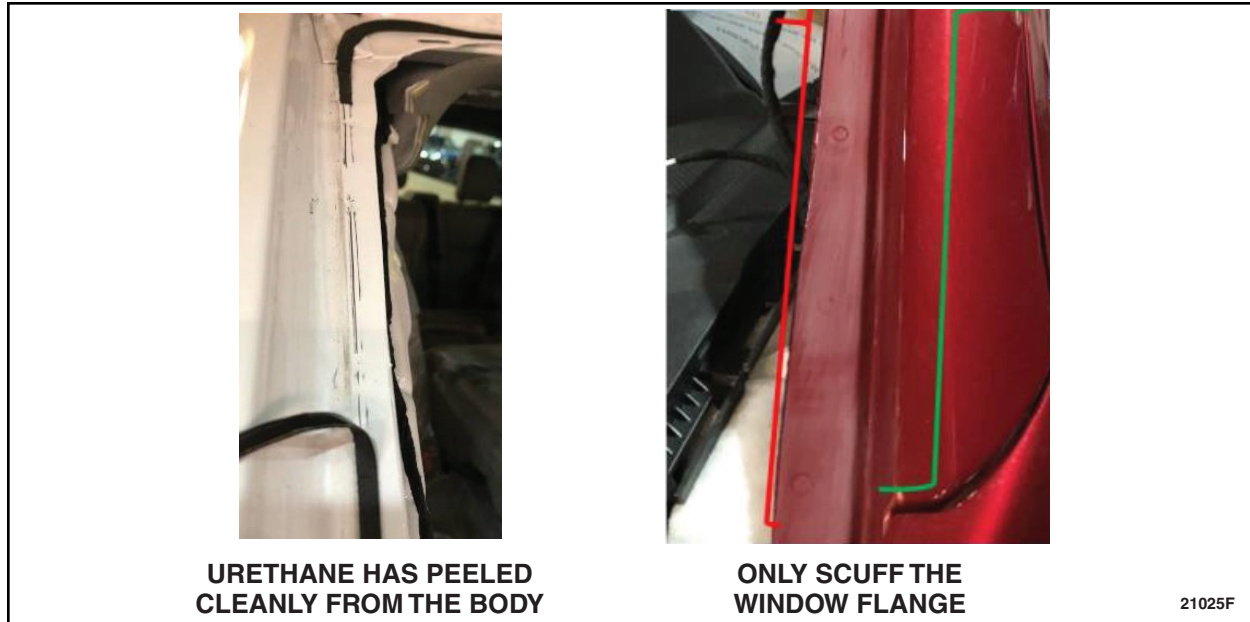

FIGURE 2

- In areas where the urethane did not peel up cleanly, use a Scotch-Brite 3M Roloc disk to remove all remaining urethane from flange while attempting to minimize abrasion to the painted surface. See Figure 3.

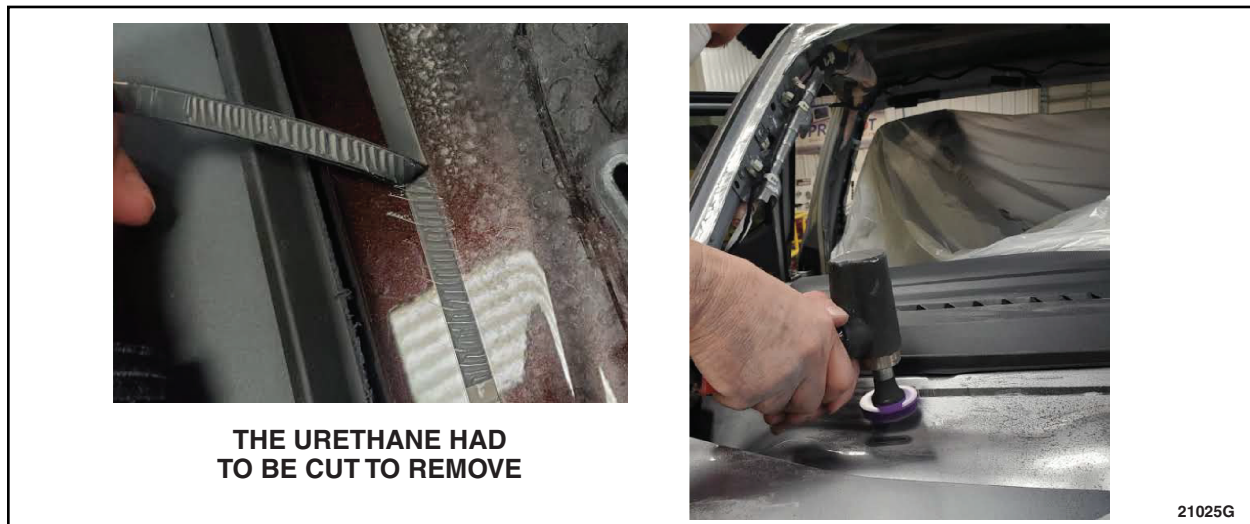

FIGURE 3

- Remove the protective cover from the vehicle and clean off the entire windshield flange from all dirt and debris.
- Using Isopropyl Alcohol and a lint-free cloth, clean off the flange surface.



9. Apply tape to the edges of the windshield flange to protect the surface of the vehicle. See Figure 4.



FIGURE 4

10. Apply one coat of any Ford approved epoxy based repair primer to any spots where the roloc disk was used to grind off the urethane. Allow time for the primer to dry per the manufacturer's instructions. See Figure 5.



FIGURE 5

BODY SHOP - PART TWO

NOTE: Part Two may only be performed once the Glass Company repair procedures have been completed.

11. After the windshield has been properly installed and the urethane has dried per the manufacturer's instructions, carry out the Image Processing Module A (IPMA) Camera alignment using a scan tool.



CERTAIN 2021 MODEL YEAR F-150 and 2020-2021 MODEL YEAR SUPER DUTY VEHICLES — WINDSHIELD GLASS REATTACHMENT

NEW ! SERVICE PROCEDURE

NOTE: These instructions are not intended to be followed from beginning to end. There are several locations where procedures must be completed by other groups before the procedure in these instructions can be resumed.

The instructions should be followed in this order.

1. Glass Company – Remove windshield – Steps 1-27 as required.
2. Body Shop – Improve Flange adhesion – Steps 1-10 as required.
3. Glass Company – Install windshield – Steps 28-36
4. Body Shop – Calibrate Image Processing Module A – Step 11

GLASS COMPANY - PART ONE

1. Raise the windshield wiper pivot arms into the SERVICE-UP position. See Figure 1.

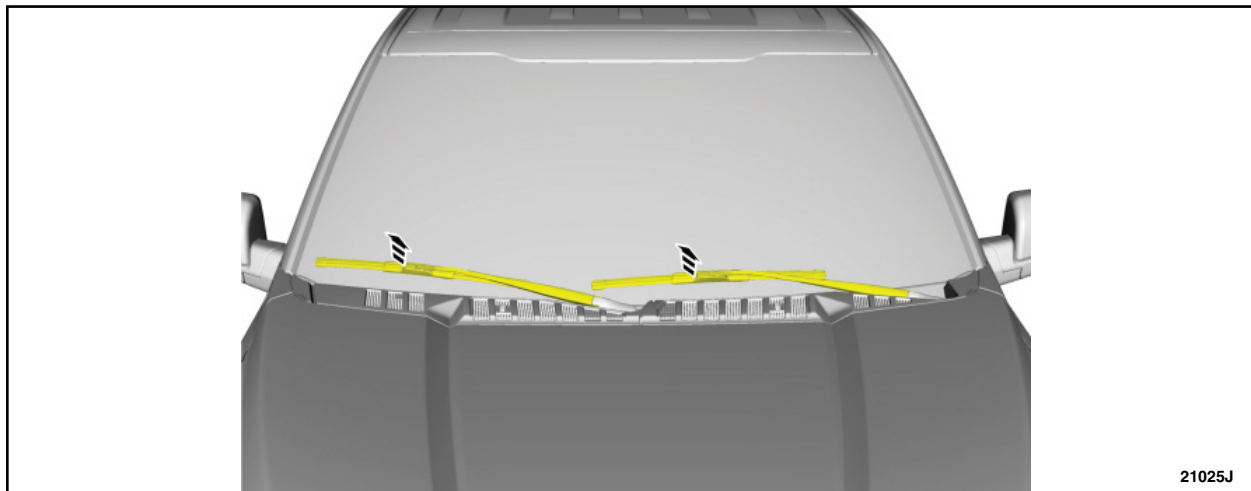

FIGURE 1

2. Remove the windshield wiper pivot arms. See Figure 2.
 1. Release the windshield wiper pivot arm latch.
 2. Remove the windshield wiper pivot arm.

NOTE: During installation, it is necessary to fully release the windshield wiper pivot arm latch and hold while installing the pivot arm onto the wiper linkage assembly.



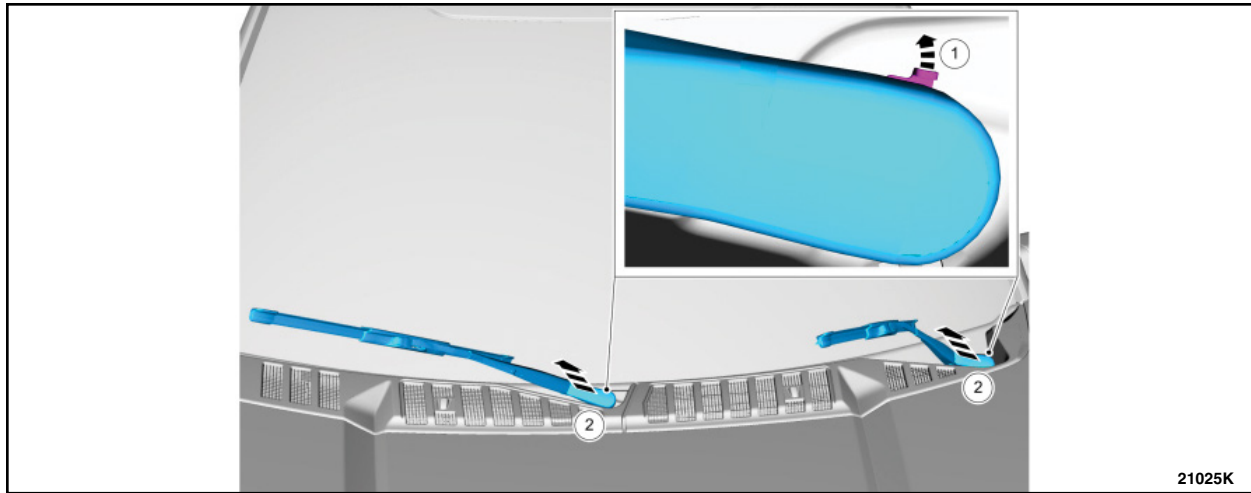

FIGURE 2

3. Release the left hand side tabs and lift the cowl trim panel to release the underside pin-type retainers. See Figure 3.

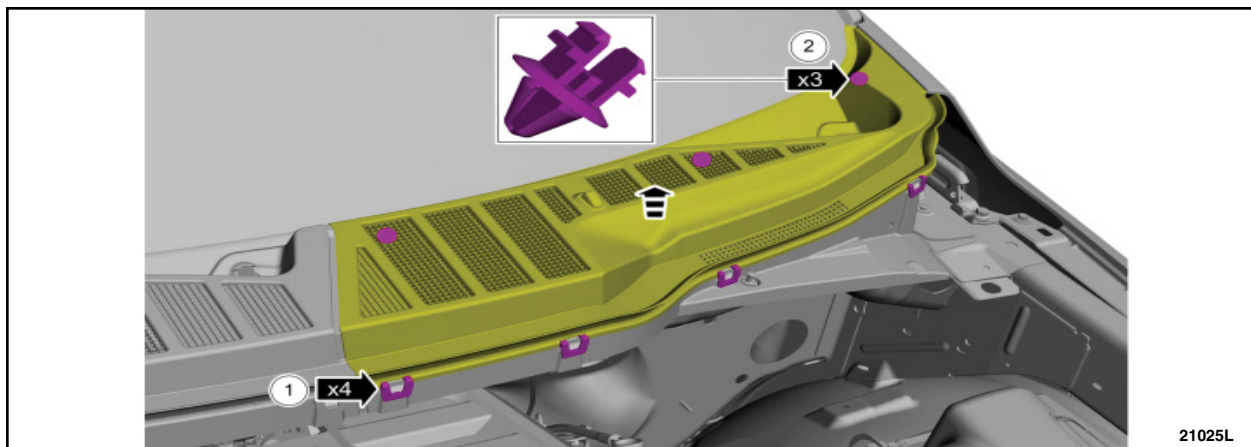

FIGURE 3

4. Disconnect the windshield washer tube and remove the cowl panel grille. See Figure 4.

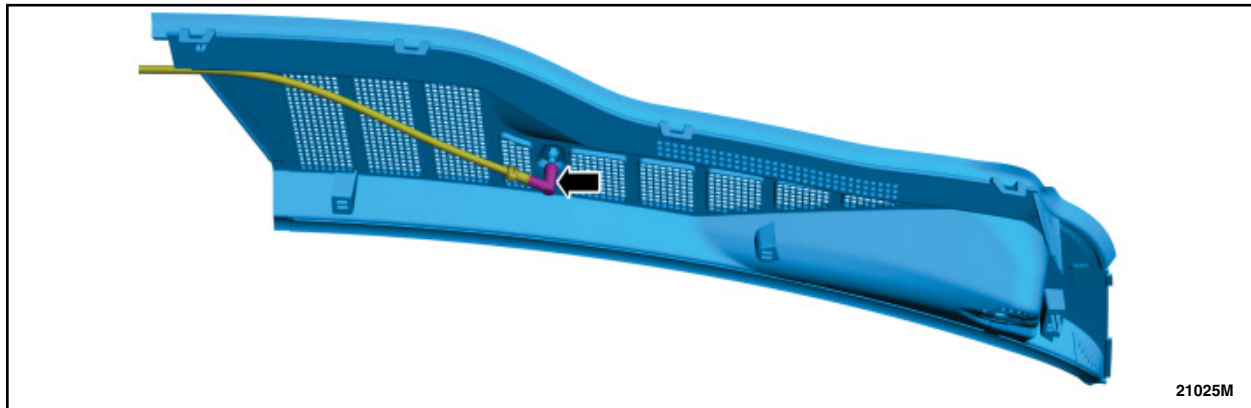

FIGURE 4



5. Release the right hand side tabs and lift the cowl trim panel to release the underside pin-type retainers. See Figure 5.

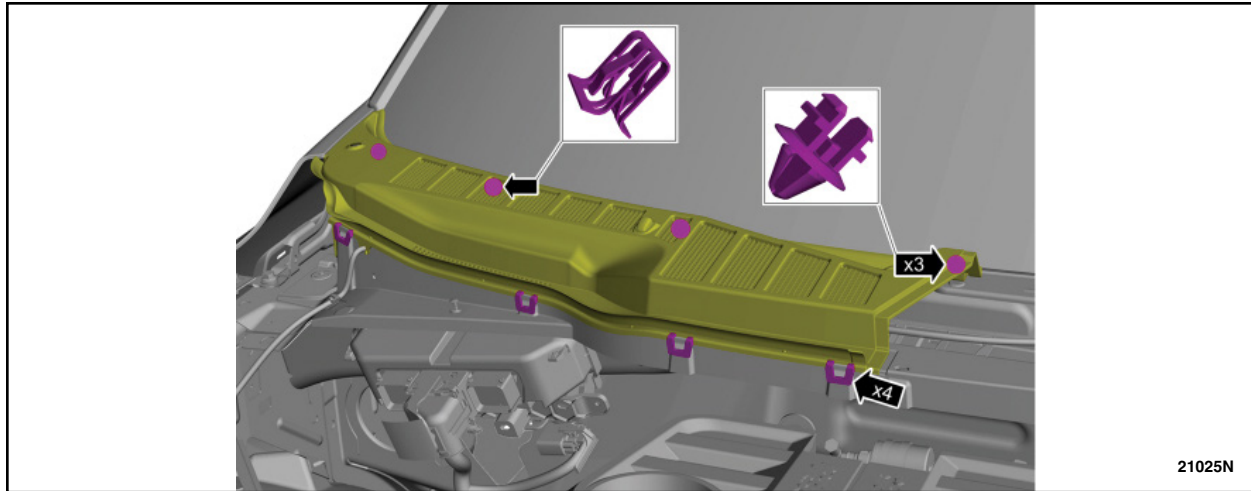

FIGURE 5

6. Disconnect the windshield washer tube and remove the cowl panel grille. See Figure 6.

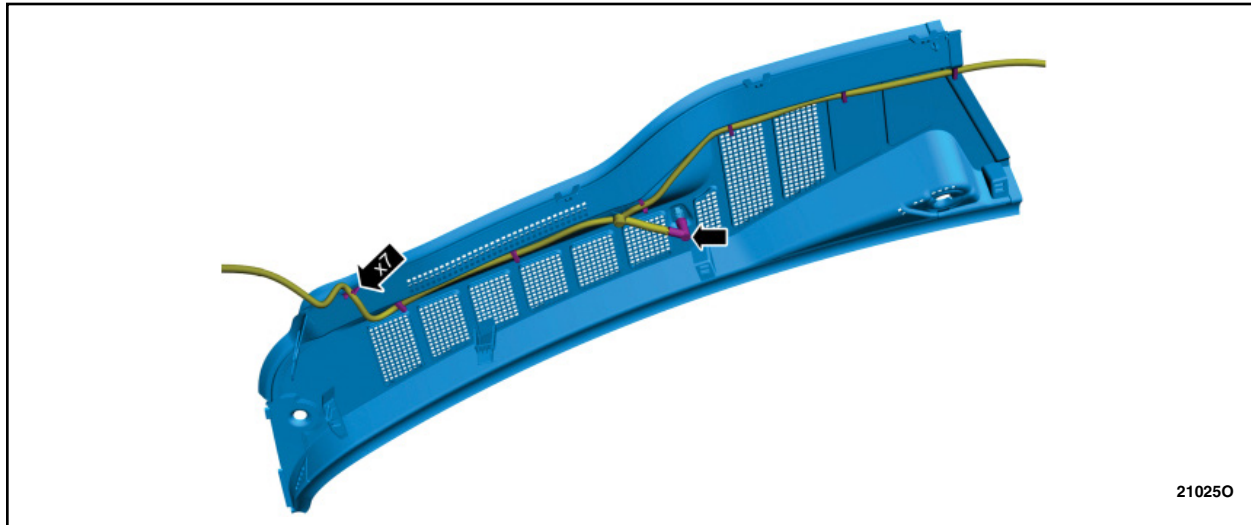

FIGURE 6



7. Remove the sun visor on both sides. See Figure 7.
 1. Remove the bolt cover.
 2. Remove the bolt.
 3. Remove the sun visor.
 4. If equipped, disconnect the sun visor electrical connector.

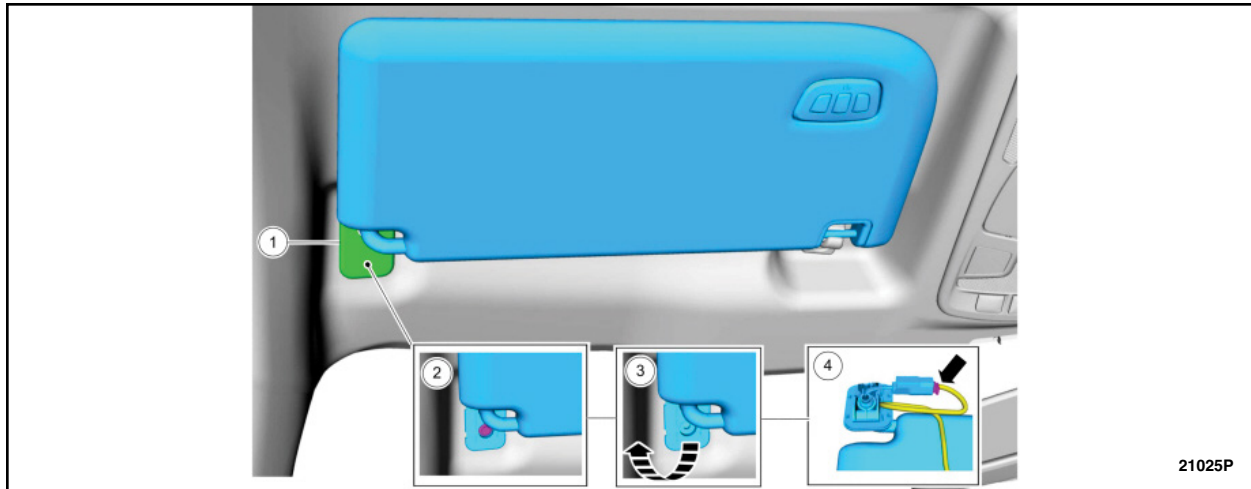

FIGURE 7

8. Mirror Types. See Figure 8.

NOTE: The location and number of electrical connectors may vary based on vehicle application.

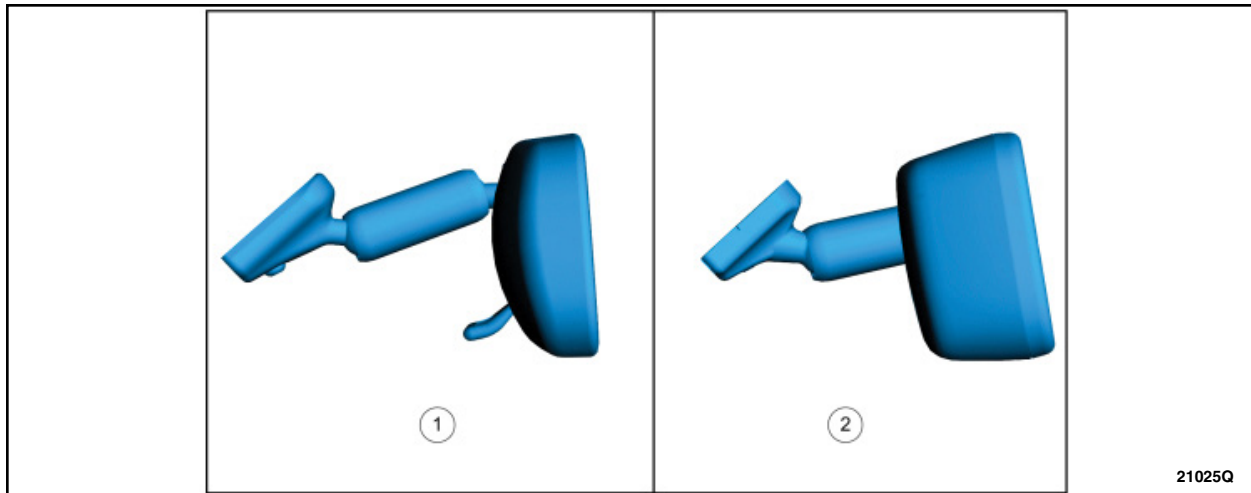

FIGURE 8



9. If equipped, remove the *camera*/rain sensor cover. See Figure 9.

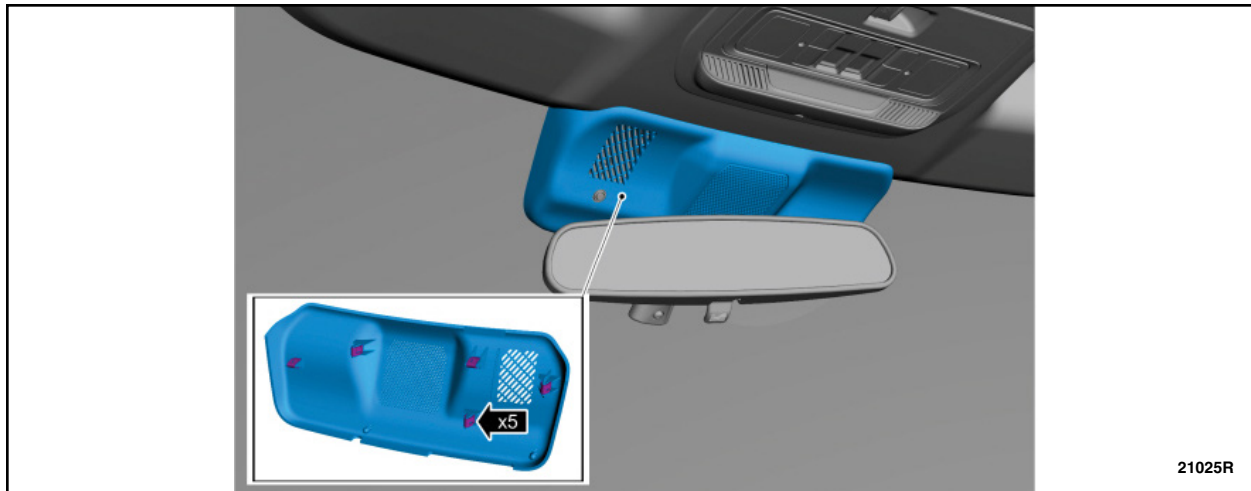

FIGURE 9

10. See Figure 10.

1. Disconnect the rain sensor electrical connector.
2. Disconnect the humidity and temperature sensor electrical connector.

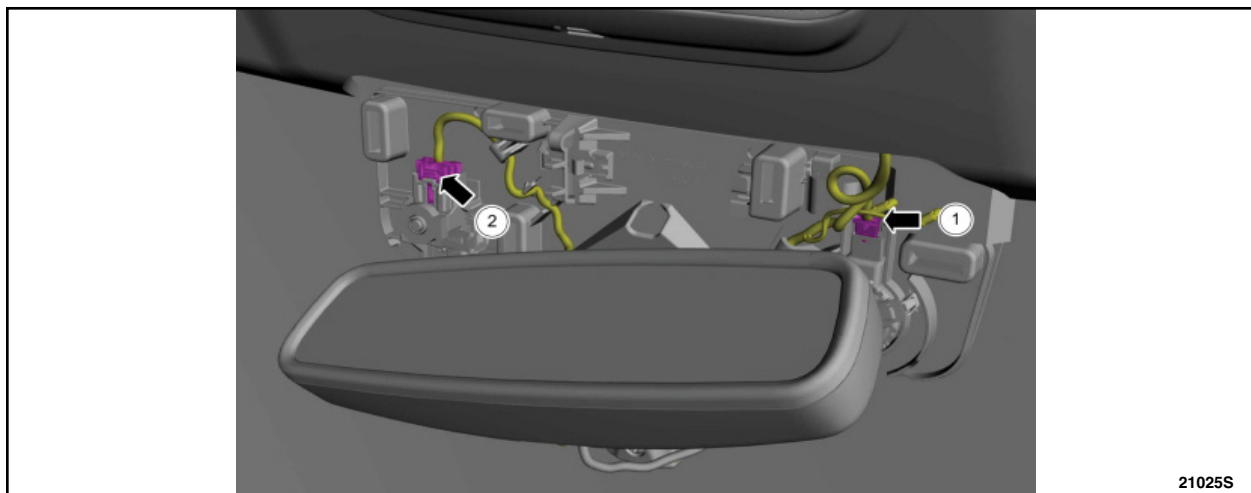

FIGURE 10



11. Disconnect the electrical connector and unclip the wiring harness. See Figure 11.

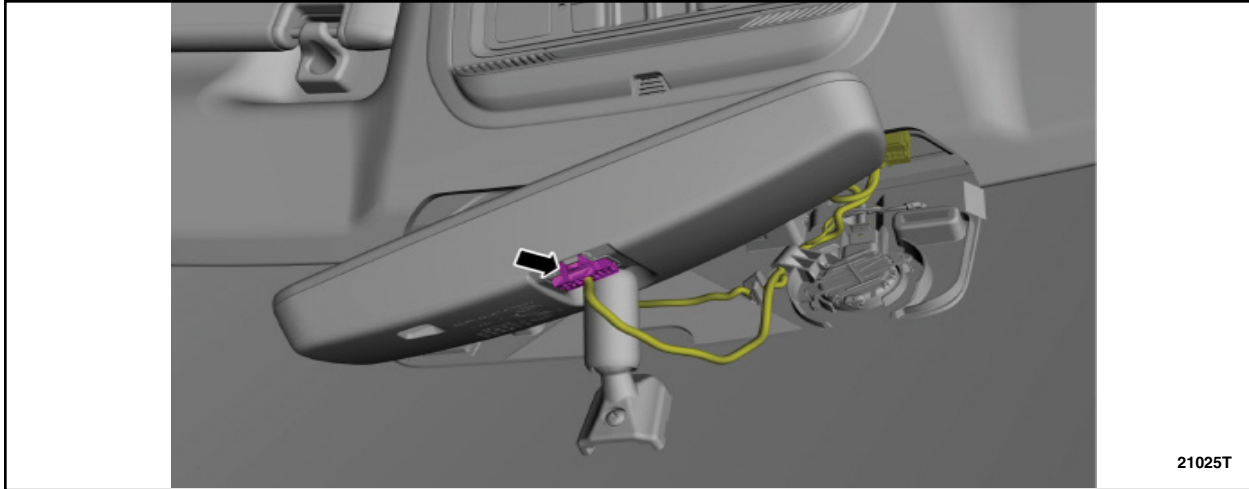

FIGURE 11

12. Remove the interior mirror. See Figure 12.

1. Loosen the set screw.
 - Torque: 17 lb.in (1.9 Nm)
2. Slide the interior mirror upward.

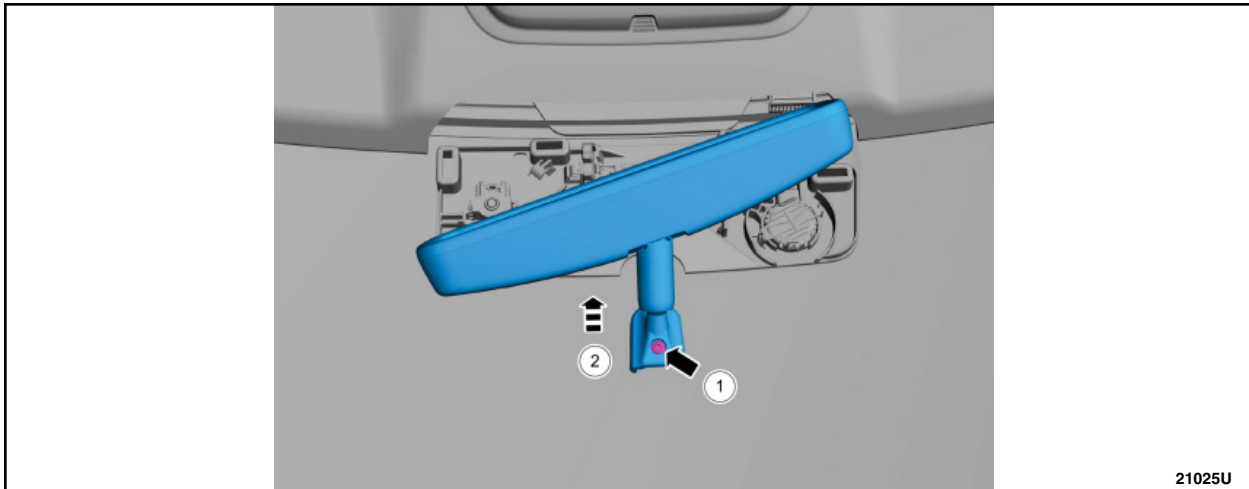

FIGURE 12



13. Release the tabs and remove the assist handle cover. See Figure 13.
Use the General Equipment: Pick Hook

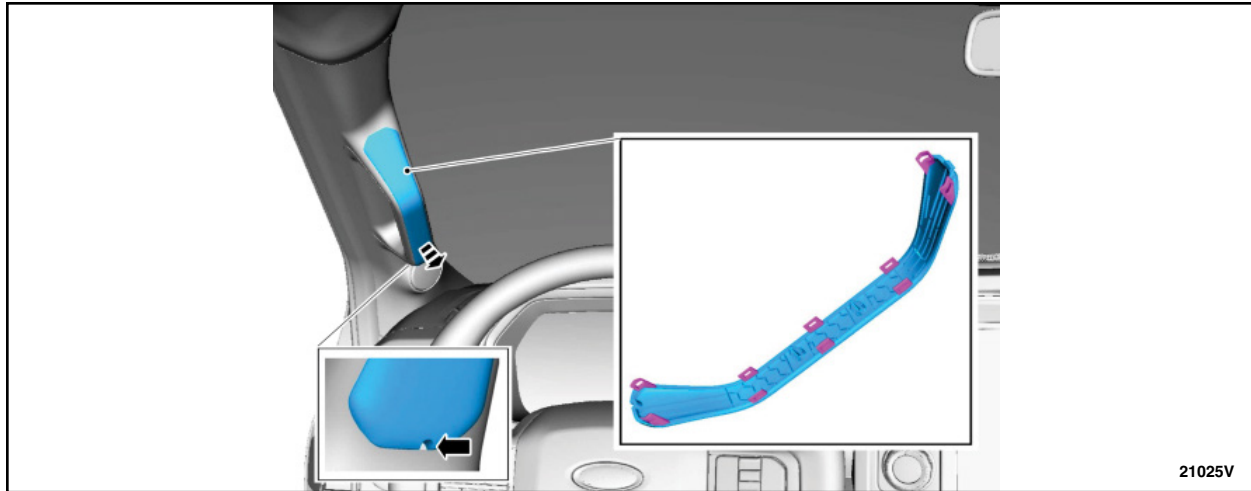

FIGURE 13

14. Remove the assist handle bolts. See Figure 14.
• Torque: 80 lb.in (9 Nm)

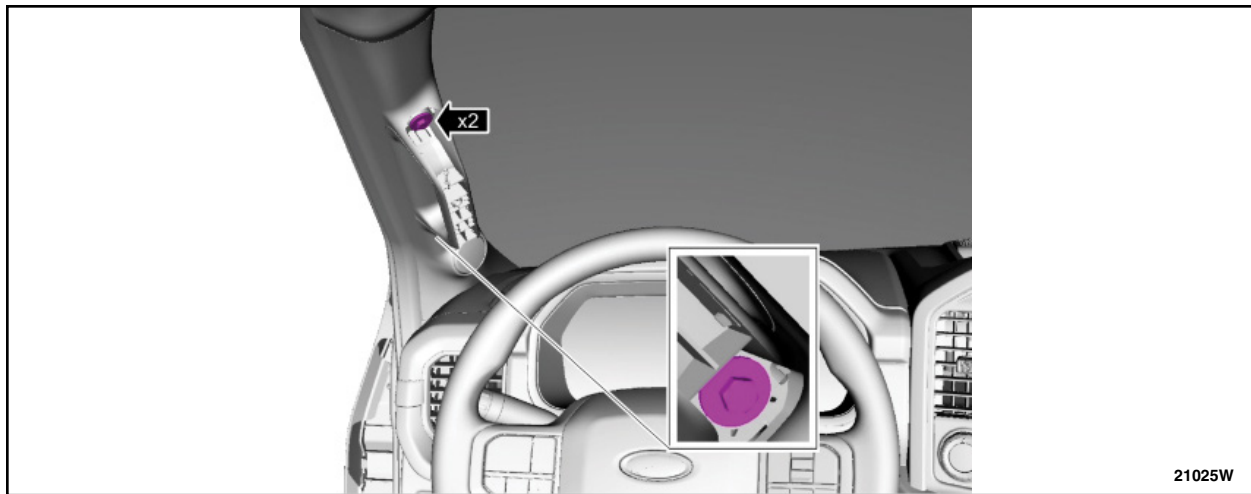

FIGURE 14



15. Remove the A-pillar trim panel. See Figure 15.
1. Release the A-pillar trim panel clip.
 2. Lift upward and outward to disengage the A-pillar trim panel lower tabs.
 3. If equipped, disconnect the front tweeter speaker electrical connector.

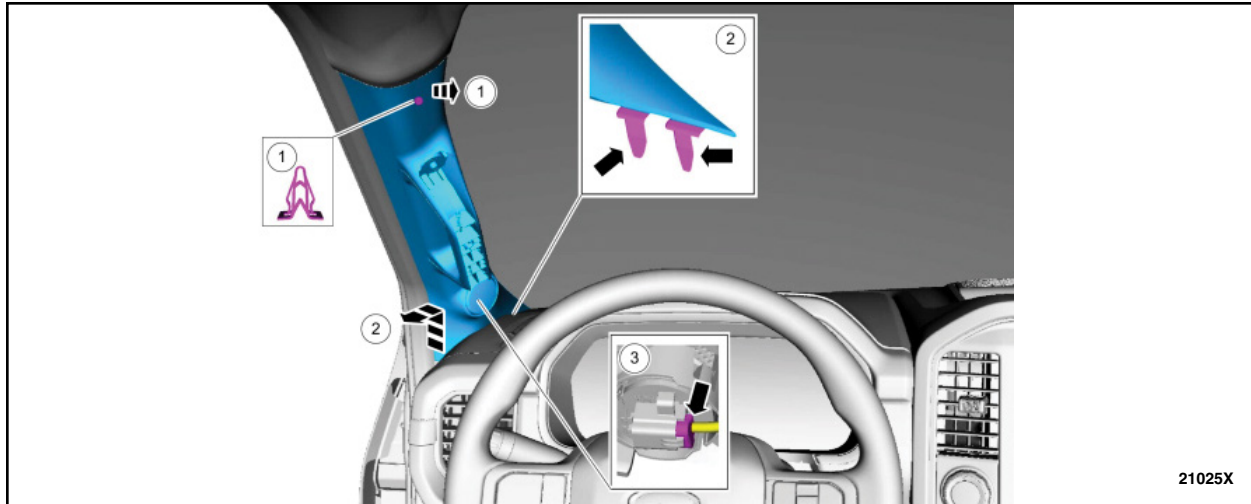

FIGURE 15

16. When installing, inspect and position the front door weather strip lip so that it overlaps the top of the A-pillar trim panel. See Figure 16.

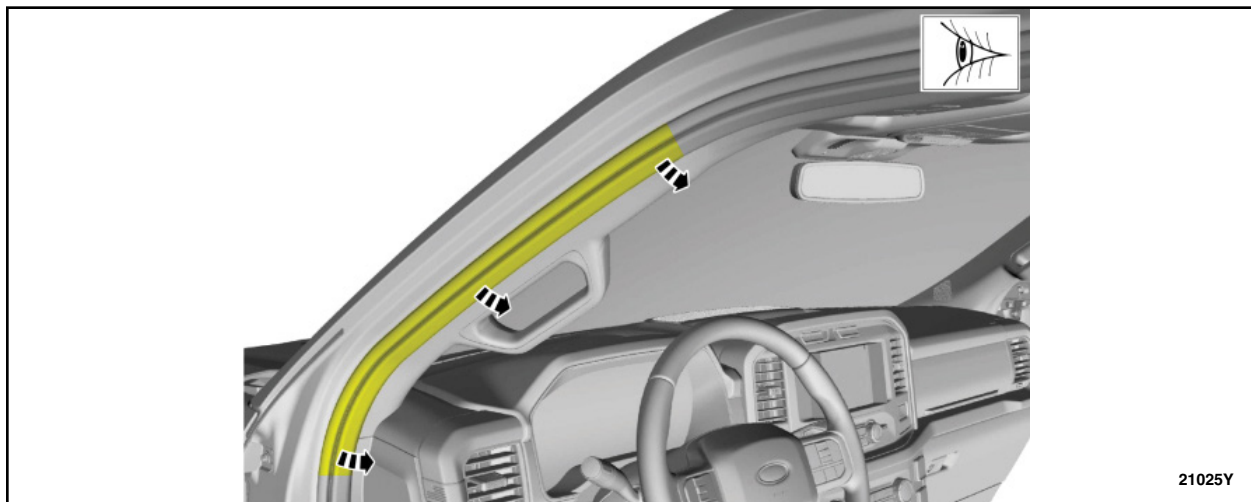
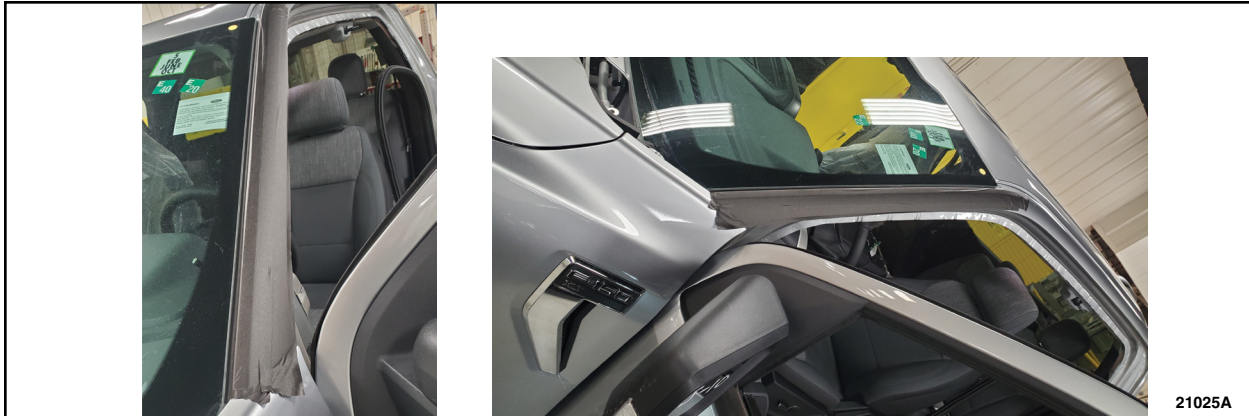

FIGURE 16

17. Apply tape to the perimeter of the windshield to protect from paint damage. See Figure 17.

NOTE: *Tape off the roof panel near the centerline of the vehicle, where the roof extends forward. When using a piano wire to cut out the glass, the wire will roll over the class A paint in the roof area, once tension is applied to it. If using a nylon style string, this will not damage the paint.*





21025A

FIGURE 17

18. Remove the windshield using a piano wire cut out tool. See Figure 18.

NOTE: Manually route the wire under the rubber moldings on either side of the window to prevent damage. See Figure 19.



21025D

FIGURE 18

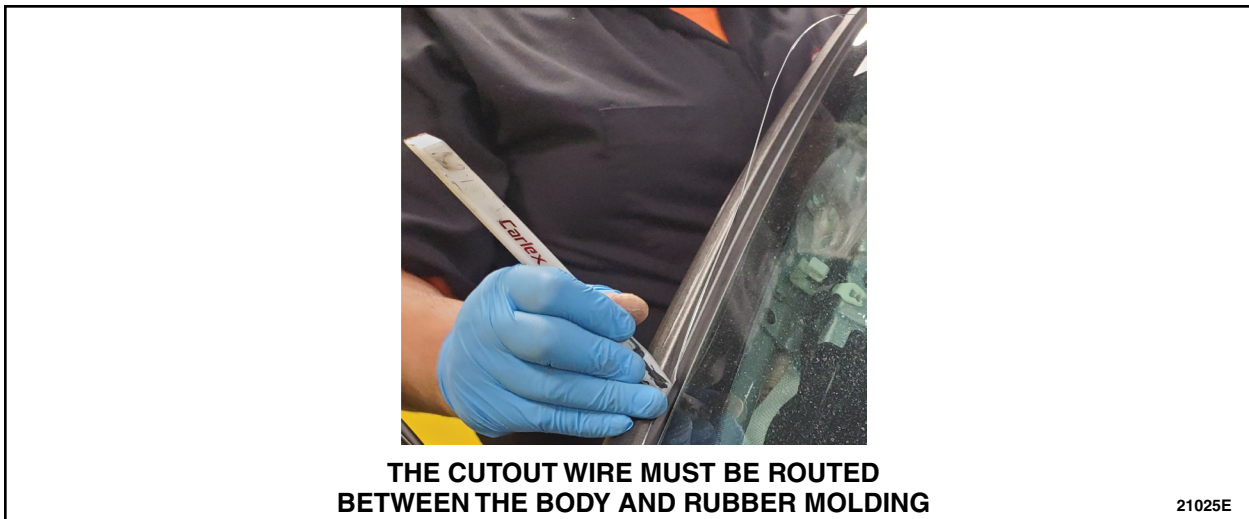

**THE CUTOUT WIRE MUST BE ROUTED
BETWEEN THE BODY AND RUBBER MOLDING**

21025E

FIGURE 19



19. Inspect the rubber molding on both sides of the windshield for possible damage. Is there any damage to the molding on either side?

Yes – Replace the windshield. Proceed to Step 20.

No – Re-install the original windshield. Proceed to Step 28.

NOTE: Damage to the alignment pins does not require windshield replacement.

20. Use glass cleaner to clean the surface of the new windshield to be installed.

21. Release the tabs and remove the in-vehicle temperature and humidity sensor. See Figure 20.

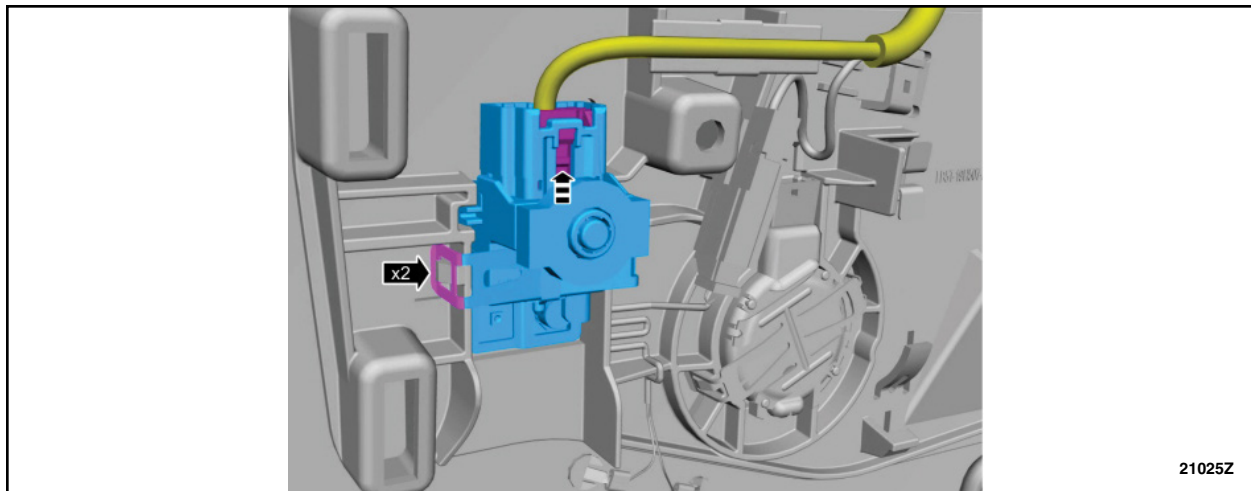

FIGURE 20

22. Re-install the temperature and humidity sensor into the new windshield.

23. Remove the Image Processing Module A (IPMA) Camera. See Figure 21.

1. Release the tab.

2. Release the tab and remove the IPMA camera.

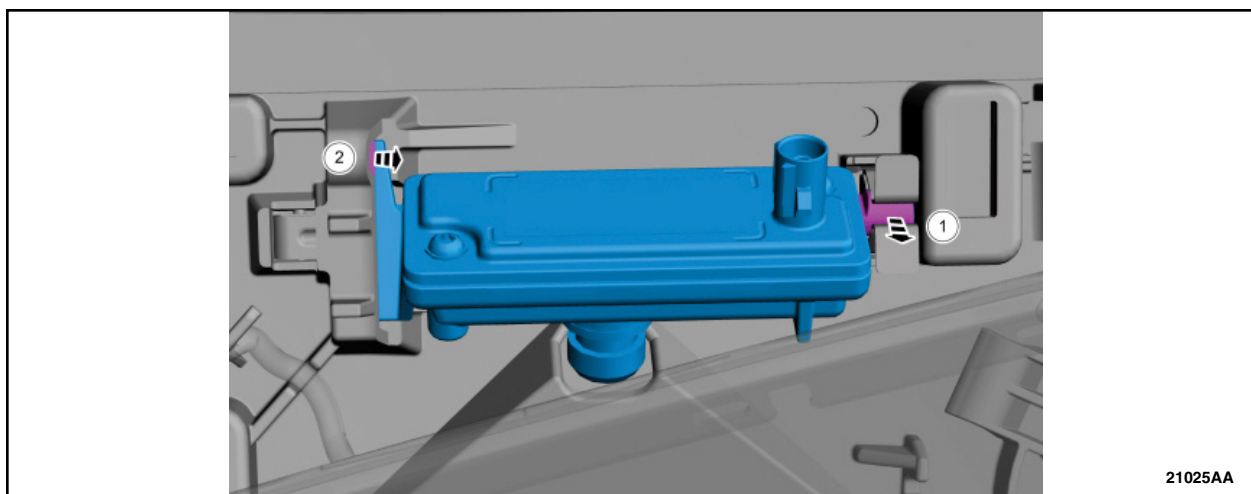

FIGURE 21



24. Re-install the IPMA camera into the new windshield.
25. Remove the rain sensor. See Figure 22.
 1. Release the retainers.
 2. Remove the rain sensor.

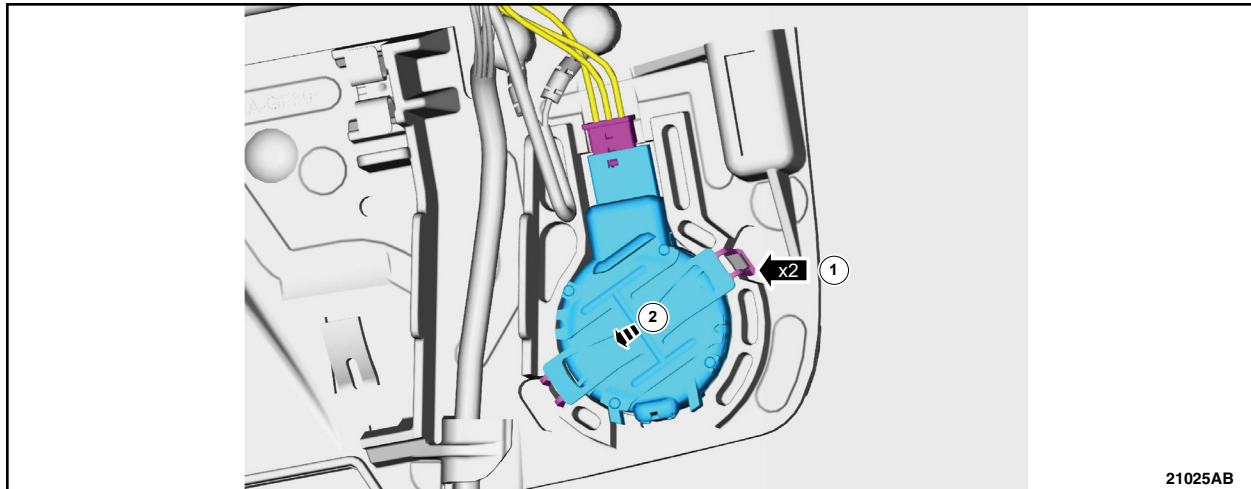

FIGURE 22

26. Inspect the rain sensor gel pack for damage. See Figure 23.

NOTE: If the rain sensor gel pack is damaged, install a new rain sensor.

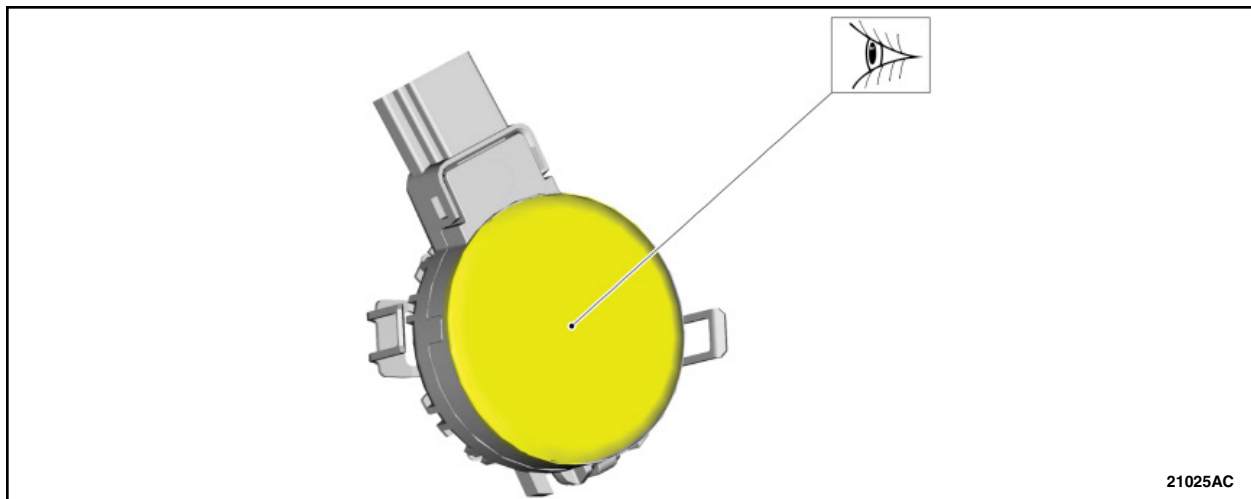

FIGURE 23

27. Re-install the rain sensor into the new windshield.



GLASS COMPANY - PART TWO

NOTE: Part Two may only be performed once the Body Shop repair procedures to the window flange have been completed.

28. Shave down the urethane on the original windshield until there is 1mm remaining. See Figure 24.



FIGURE 24

29. Apply two coats of *urethane body flange* primer according to the manufacturer's instructions to the entire *windshield body* flange at the urethane location. Additionally, apply two coats of window primer at any location where the clearcoat or paint layers have been damaged to provide environmental protection. Allow dry time between each coat applied.

Material: Dow® BETAPRIME™ 5504G / Sika® Primer-207

30. Apply window primer according to the manufacturer's instructions to the new windshield. Allow dry time.

Material: Dow® BETAPRIME™ 5504G / Sika® Primer-207

NOTE: This step only applies when replacing the windshield.

31. Apply window primer according to the manufacturer's instructions to the fixed glass anywhere the urethane adhesive was completely removed. Allow dry time.

Material: Dow® BETAPRIME™ 5504G / Sika® Primer-207

NOTE: This step only applies when reusing the original windshield.



32. Cut the urethane adhesive applicator tip to specification. See Figure 25.

Material: Sika® SikaTack® MACH 60 / Sika® SikaTack® MACH 30 / Dow® BETASEAL™ Express
Material: Sika Tack ASAP Urethane Adhesive

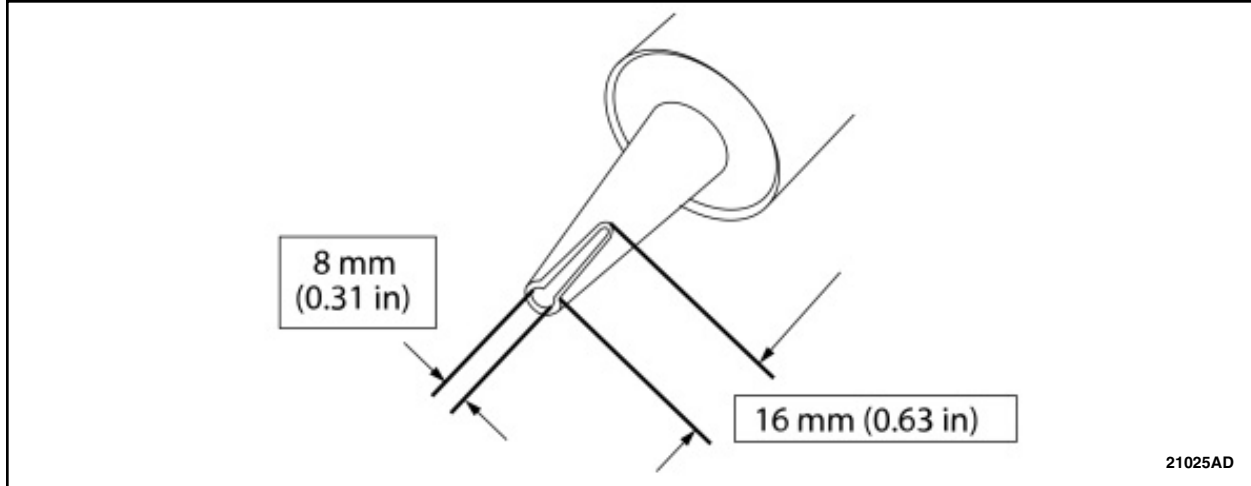

FIGURE 25

33. Apply a urethane adhesive bead. See Figure 26.

1. Start and end at the original overlap points to prevent air and water leaks.
2. Apply a urethane adhesive bead 14 mm (0.551 in) high and 8 mm (0.314 in) wide on top of the existing trimmed urethane adhesive bead on the pinch weld.
3. Make sure there are no gaps in the bead.

NOTICE: Make sure the urethane bead is uniform to prevent air and water leaks.

NOTE: The fixed glass must be installed within 10 minutes of applying the urethane adhesive.

NOTE: Use a power caulk gun that applies the urethane adhesive with less effort and a continuous bead.

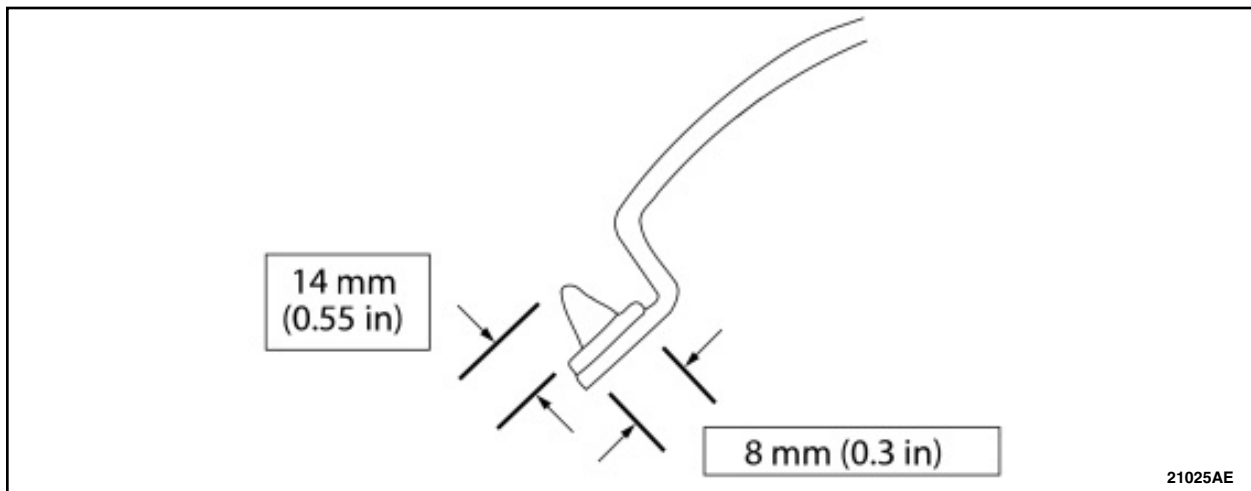

FIGURE 26



34. Open the vehicle windows to prevent the air pressure of closing doors from compromising the urethane adhesive bond.

NOTICE: The door windows must be left open during the adhesive curing time.

35. Install the fixed glass to the vehicle.

1. Install the fixed glass, pressing firmly by hand to ensure a good bond.
2. Secure the fixed glass in the correct position with tape until the urethane adhesive has cured.

⚠ WARNING: Do not drive vehicle until the urethane adhesive seal has cured. Follow urethane adhesive manufacturer's curing directions. Inadequate or incorrect curing of the urethane adhesive seal will adversely affect glass retention. Failure to follow these instructions may result in serious injury to vehicle occupant(s).

36. Re-install all previously removed components by reversing steps 1-16.

