

Product Safety Recall

N202322235 Seat Belt May Not Be Properly Attached



Release Date: December 2020

Revision: 00

Attention: It is a violation of Federal law for a dealer to deliver a new motor vehicle or any new or used item of motor vehicle equipment (including a tire) covered by this notification under a sale or lease until the defect or noncompliance is remedied.

All involved vehicles that are in dealer inventory must be held and not delivered to customers, dealer traded, or used for demonstration purposes until the repair contained in this bulletin has been performed on the vehicle.

Make	Model	Model Year		RPO	Description
		From	To		
Chevrolet	Colorado	2021	2021		
GMC	Canyon				

Involved vehicles are marked “open” on the Investigate Vehicle History screen in GM Global Warranty Management system. This site should always be checked to confirm vehicle involvement prior to beginning any required inspections and/or repairs.

Condition	General Motors has decided that a defect which relates to motor vehicle safety exists in certain 2021 model year Chevrolet Colorado and GMC Canyon vehicles. In these vehicles, the wrong seat-belt bolt may have been used at one or more fastening locations to secure the seat belt to the vehicle. If an incorrect bolt was used, the seat belt may not be properly attached to the vehicle. If a seat belt assembly is not properly attached to the vehicle, the seat belt may not properly restrain an occupant, increasing risk of occupant injury in a crash.
Correction	Dealers will replace bolts at suspect seat-belt attachment locations.

Parts

Quantity	Part Name	Part No.
As Required	Bolt	11611776

Important: Due to limited initial parts availability, parts should only be ordered when a Dealer has a vehicle with a VIN that is subject to this Recall. If the VIN is subject to this Recall, its recall status in IVH should be listed as “open.” We have also attached information below to access involved VINs for your convenience.

Reminder: Parts may be removed from Retail Inventory Management (RIM). Dealers should review the affected parts to confirm RIM managed status. Parts may have quantity limiters in effect.

Warranty Information

Labor Operation	Description	Labor Time	Trans. Type	Net Item
9105537	Replace Front Row Seat Belt Retractor Mounting Bolt (As Required)	0.6	ZFAT	N/A
9105538	Replace Second Row Outer Seat Belt Retractor and Seat Belt Anchor Mounting Bolt	1.0		
	ADD: for Crew Cab (Two Bolts)	0.3		

Service Procedure

IMPORTANT: Not all seat belt system attachment bolts require replacement. Please refer to the VIN table provided below, and search for the VIN of the vehicle you are servicing to determine which seat belt system attachment bolt requires replacement.

Product Safety Recall

N202322235 Seat Belt May Not Be Properly Attached



	A	B	C	D	E
1	VIN	MODEL YR	MAKE	MODEL	LOCATION
2	1GCGSCEN9M1154253	2021	Chevrolet	Colorado	Driver 2nd Row Seat Belt Retractor & Seat Belt Anchor
3	1GCGTBENXM1145861	2021	Chevrolet	Colorado	Passenger 2nd Row Seat Belt Retractor & Seat Belt Anchor
4	1GCGTBENXM1154737	2021	Chevrolet	Colorado	Driver 2nd Row Seat Belt Retractor & Seat Belt Anchor
5	1GCGTCEN0M1146281	2021	Chevrolet	Colorado	Driver 2nd Row Seat Belt Retractor & Seat Belt Anchor
6	1GCGTDEN5M1154852	2021	Chevrolet	Colorado	Driver 2nd Row Seat Belt Retractor & Seat Belt Anchor
7	1GCGTDEN9M1148830	2021	Chevrolet	Colorado	Passenger 2nd Row Seat Belt Retractor & Seat Belt Anchor
8	1GCHSBEA5M1159025	2021	Chevrolet	Colorado	Passenger 1st Row Seat Belt Retractor & Pretensioner
9	1GCHSBEAXM1159103	2021	Chevrolet	Colorado	Passenger 1st Row Seat Belt Retractor & Pretensioner
10	1GCHSBEN7M1149261	2021	Chevrolet	Colorado	Driver 2nd Row Seat Belt Retractor
11	1GCHSCEA0M1159472	2021	Chevrolet	Colorado	Passenger 1st Row Seat Belt Retractor & Pretensioner
12	1GCHSCEA5M1159399	2021	Chevrolet	Colorado	Passenger 1st Row Seat Belt Retractor & Pretensioner
13	1GCPTE18M1158763	2021	Chevrolet	Colorado	Driver 2nd Row Seat Belt Retractor & Seat Belt Anchor
14	1GTG6EEN5M1149258	2021	GMC	Canyon	Driver 2nd Row Seat Belt Retractor & Seat Belt Anchor
15	1GTG6FEN4M1142761	2021	GMC	Canyon	Driver 2nd Row Seat Belt Retractor & Seat Belt Anchor
16	1GTG6FEN4M1149886	2021	GMC	Canyon	Driver 2nd Row Seat Belt Retractor & Seat Belt Anchor
17	1GTG6FEN5M1154417	2021	GMC	Canyon	Driver 2nd Row Seat Belt Retractor & Seat Belt Anchor
18	1GTG6FEN7M1153902	2021	GMC	Canyon	Passenger 1st Row Seat Belt Retractor
19	1GTG6FEN8M1144609	2021	GMC	Canyon	Driver 2nd Row Seat Belt Retractor & Seat Belt Anchor
20	1GTP6EE11M1159704	2021	GMC	Canyon	Driver 2nd Row Seat Belt Retractor & Seat Belt Anchor

5699114

1	VIN/NIV	MODEL/Modèle	LOCATION
2	1GCGSCEN9M1154253	Colorado	Enrouleur de ceinture de sécurité et dispositif d'ancrage de ceinture de sécurité de deuxième rangée du côté conducteur
3	1GCGTBENXM1145861	Colorado	Enrouleur de ceinture de sécurité et dispositif d'ancrage de ceinture de sécurité de la deuxième rangée du côté passager
4	1GCGTBENXM1154737	Colorado	Enrouleur de ceinture de sécurité et dispositif d'ancrage de ceinture de sécurité de deuxième rangée du côté conducteur
5	1GCGTCEN0M1146281	Colorado	Enrouleur de ceinture de sécurité et dispositif d'ancrage de ceinture de sécurité de deuxième rangée du côté conducteur
6	1GCGTDEN5M1154852	Colorado	Enrouleur de ceinture de sécurité et dispositif d'ancrage de ceinture de sécurité de deuxième rangée du côté conducteur
7	1GCGTDEN9M1148830	Colorado	Enrouleur de ceinture de sécurité et dispositif d'ancrage de ceinture de sécurité de la deuxième rangée du côté passager
8	1GCHSBEA5M1159025	Colorado	Enrouleur et prétendeur de ceinture de sécurité de la première rangée du côté passager
9	1GCHSBEAXM1159103	Colorado	Enrouleur et prétendeur de ceinture de sécurité de la première rangée du côté passager
10	1GCHSBEN7M1149261	Colorado	Enrouleur de ceinture de sécurité de deuxième rangée du côté conducteur
11	1GCHSCEA0M1159472	Colorado	Enrouleur et prétendeur de ceinture de sécurité de la première rangée du côté passager
12	1GCHSCEA5M1159399	Colorado	Enrouleur et prétendeur de ceinture de sécurité de la première rangée du côté passager
13	1GCPTE18M1158763	Colorado	Enrouleur de ceinture de sécurité et dispositif d'ancrage de ceinture de sécurité de deuxième rangée du côté conducteur
14	1GTG6EEN5M1149258	Canyon	Enrouleur de ceinture de sécurité et dispositif d'ancrage de ceinture de sécurité de deuxième rangée du côté conducteur
15	1GTG6FEN4M1142761	Canyon	Enrouleur de ceinture de sécurité et dispositif d'ancrage de ceinture de sécurité de deuxième rangée du côté conducteur
16	1GTG6FEN4M1149886	Canyon	Enrouleur de ceinture de sécurité et dispositif d'ancrage de ceinture de sécurité de deuxième rangée du côté conducteur
17	1GTG6FEN5M1154417	Canyon	Enrouleur de ceinture de sécurité et dispositif d'ancrage de ceinture de sécurité de deuxième rangée du côté conducteur
18	1GTG6FEN7M1153902	Canyon	Enrouleur de ceinture de sécurité de première rangée du côté passager
19	1GTG6FEN8M1144609	Canyon	Enrouleur de ceinture de sécurité et dispositif d'ancrage de ceinture de sécurité de deuxième rangée du côté conducteur
20	1GTP6EE11M1159704	Canyon	Enrouleur de ceinture de sécurité et dispositif d'ancrage de ceinture de sécurité de deuxième rangée du côté conducteur

5699163

NOTE: The bolt being removed from the vehicle may not have cut the proper threads in the nut when the vehicle was manufactured. If this occurred, expect to feel resistance for the complete bolt length when removing the bolt. When the new bolt is being installed in an unthreaded nut, there will be resistance as the self-threading bolt threads the nut. There will be an initial resistance while the thread is being cut, followed by a reduction in resistance. This is an expected condition. Continue tightening the bolt until the retractor or belt bracket is secured. To complete the installation, tighten the bolt to the proper torque specification.

Service Procedure for First Row Outer Seatbelt Retractor Mounting Bolt (Crew Cab Models)

1. Remove the center pillar lower trim panel. It is not necessary to disconnect the seat belt from the seat belt anchor plate tensioner. Refer to *Center Pillar Lower Trim Panel Replacement* in SI.

Product Safety Recall

N202322235 Seat Belt May Not Be Properly Attached

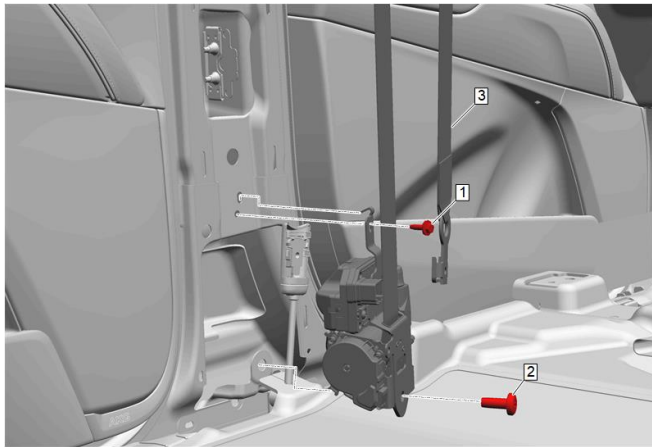

5618244

2. Remove and discard the lower retractor bolt (2).
3. Install the new retractor mounting bolt. Refer to the note above for installation details. Tighten the new service bolt to 45 N.m (33 lb. ft).
4. Reinstall the center pillar lower trim panel. Refer to *Center Pillar Lower Trim Panel Replacement* in SI.

Service Procedure for First Row Outer Seatbelt Retractor and Pretensioner Mounting Bolt (Extended Cab Models)

1. Remove the rear side door trim panel. Refer to *Rear Side Door Trim Replacement (Extended Cab)* in SI. It is not necessary to disconnect any seat belt locations.

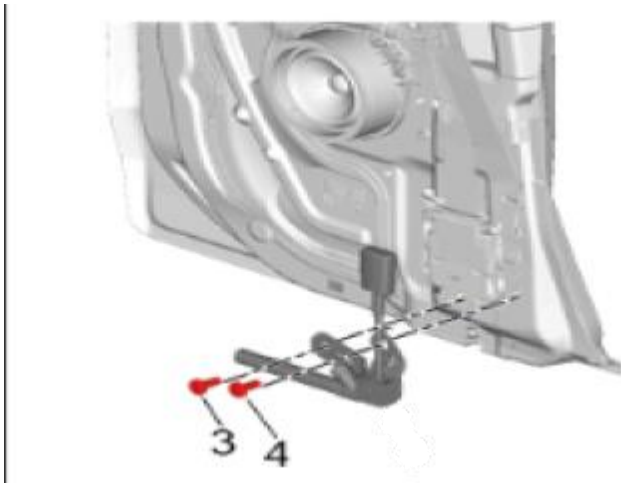

5697062

2. Remove the seat belt retractor (3) and the seat belt anchor plate (4) mounting bolts. Discard the bolts.
3. Install **TWO** new mounting bolts at the seat belt retractor (3) and the seat belt anchor plate (4) locations. Refer to the note above for installation details. Tighten the new service bolts to 45 N.m (33 lb. ft).

Service Procedure for Second Row Outer Seatbelt Retractor and Seat Belt Anchor Bolt Replacement (Crew Cab Models)

NOTE: When performing the following steps, it is not necessary to disconnect the seat belts.

1. Remove the body lock pillar garnish molding. Refer to *Body Lock Pillar Garnish Molding Replacement* in SI.

Product Safety Recall

N202322235 Seat Belt May Not Be Properly Attached

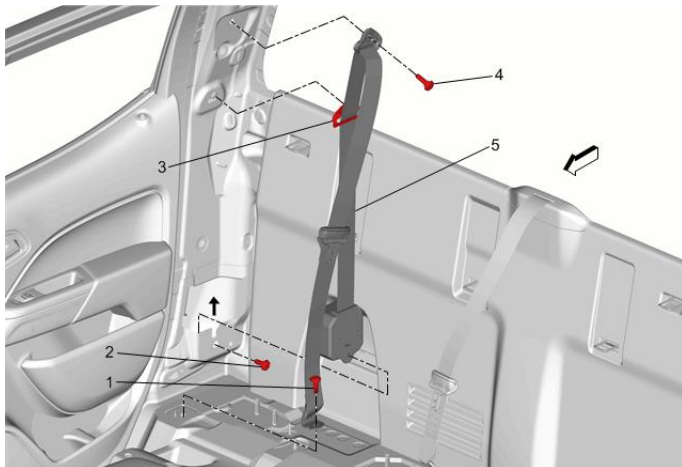

2. Remove the second-row retractor mounting (2) and seat belt anchor (1) bolt. Discard the bolts.
3. Install **TWO** new mounting bolts at the seat belt retractor (2) and the seat belt anchor plate (1) locations. Refer to the note above for installation details. Tighten the new service bolts to 45 N.m (33 lb. ft).
4. Reinstall the body lock pillar garnish molding. Refer to *Body Lock Pillar Garnish Molding Replacement* in SI.

Service Procedure for Second Row Outer Seatbelt Retractor Mounting Bolt Replacement (Extended Cab Models)

1. Remove the body side rear window garnish molding. Refer to *Body Side Rear Window Garnish Molding Replacement Extended Cab* in SI.

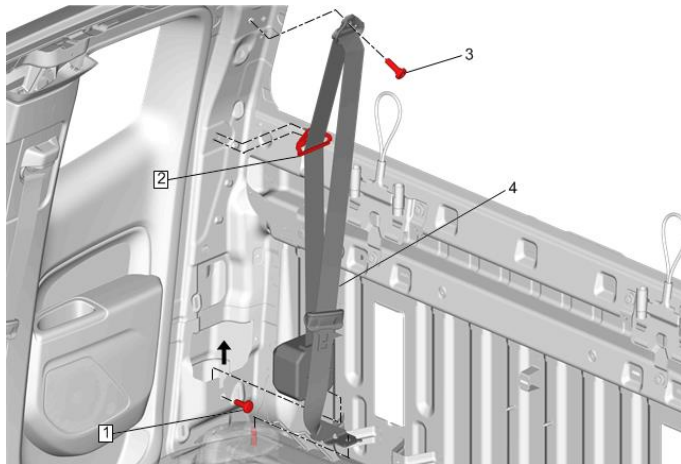

2. Remove the second-row retractor mounting (1) bolt. Discard the bolt.
3. Install the new retractor mounting bolt (1). Refer to the note above for installation details. Tighten the new service bolt to 45 N.m (33 lb. ft).

Reinstall the body side rear window garnish molding. Refer to *Body Side Rear Window Garnish Molding Replacement Extended Cab* in SI.

Dealer Responsibility – For USA & Export (USA States, Territories, and Possessions)

It is a violation of Federal law for a dealer to deliver a new motor vehicle or any new or used item of motor vehicle equipment (including a tire) covered by this notification under a sale or lease until the defect or noncompliance is remedied.

The US National Traffic and Motor Vehicle Safety Act provides that each vehicle that is subject to a recall of this type must be adequately repaired within a reasonable time after the customer has tendered it for repair. A failure to repair within sixty days after tender of a vehicle is prima facie evidence of failure to repair within a reasonable time. If the condition is not adequately repaired within a reasonable time, the customer may be entitled to an identical or reasonably equivalent vehicle at no charge or to a refund of the purchase price less a reasonable allowance for depreciation. To avoid having to provide these burdensome remedies, every effort must be made to promptly schedule an appointment

Product Safety Recall

N202322235 Seat Belt May Not Be Properly Attached



with each customer and to repair their vehicle as soon as possible. In the recall notification letters, customers are told how to contact the US National Highway Traffic Safety Administration if the recall is not completed within a reasonable time.

Dealer Responsibility – All

All new, used, GM Certified Used, courtesy transportation vehicles, dealer shuttle vehicles, etc. in dealers' possession and subject to this recall must be held and inspected/repaired per the service procedure of this bulletin before customers take possession of these vehicles. Involved vehicles must be held and not delivered to customers, dealer-traded, released to auction, used for demonstration, or any other purpose.

All GM Certified Used vehicles currently in the dealers' inventory within the Certified Pre-Owned Inventory System (CPOIS) will be de-certified and must be held and remedied per the service procedure in this bulletin. Upon submitting an accepted/paid warranty transaction in the Global Warranty Management (GWM) system, the vehicle can be re-certified for sale within the CPOIS system, or once again be used in the CTP program.

Dealers are to service all vehicles subject to this recall at no charge to customers, regardless of mileage, age of vehicle, or ownership, from this time forward.

Customers who have recently purchased vehicles sold from your vehicle inventory, and for which there is no customer information indicated on the dealer listing, are to be contacted by the dealer. Arrangements are to be made to make the required correction according to the instructions contained in this bulletin. Recall follow-up cards should not be used for this purpose, since the customer may not as yet have received the notification letter.

In summary, whenever a vehicle subject to this field action enters your vehicle inventory you must take the steps necessary to ensure the program correction has been made before selling the vehicle. In addition, for vehicles entering your facility for service, you are required to ensure the customer is aware of the open field action and make every reasonable effort to implement the program correction as set forth in this bulletin prior to releasing the vehicle.

Dealer Reports

For dealers with involved vehicles, a listing has been prepared and will be available through GM GlobalConnect Maxis Field Action Reports or sent directly to export dealers. The Inventory tab of the dealer reports will contain VINs that apply to this recall. This information is intended to assist dealers with the **PROMPT COMPLETION** of these vehicles. The Customer In-Service tab will contain customer names and addresses from Motor Vehicle Registration Records. The use of such motor vehicle registration data for any purpose other than follow-up necessary to complete this recall may be a violation of law in several states.

Courtesy Transportation – For USA & Canada

Courtesy transportation is available for customers whose vehicles are involved in a product program and still within the warranty coverage period. See General Motors Service Policies and Procedures Manual for courtesy transportation program details.

Customer Notification

USA & Canada - General Motors will notify customers of this recall on their vehicle.

GM bulletins are intended for use by professional technicians, NOT a "do-it-yourselfer". They are written to inform these technicians of conditions that may occur on some vehicles, or to provide information that could assist in the proper service of a vehicle. Properly trained technicians have the tools, equipment, safety instructions, and know-how to do a job properly and safely. If a condition is described, DO NOT assume that the bulletin applies to your vehicle, or that your vehicle will have that condition. See your dealer for information on whether your vehicle may benefit from the information.



**We Support
Voluntary Technician
Certification**