



WARRANTY BULLETIN SAFETY CAMPAIGN

⚠ WARNING: All involved customers must be notified, all involved units must be corrected as per instruction herein.

Campaign no.: 2020-0008

October 15, 2020

Subject: **Possible Front Wheel Loss**

No. **2020-6**

MODEL YEAR	MODEL	ADMISSIBLE UNITS
2020	Ryker®	Go to BOSSWeb/Warranty/Campaign Monitoring to know the quantity of units in your inventory impacted by this campaign

IMPORTANT

- When a vehicle comes in for service, always type the VIN in Knowledge Center to check for pending campaigns or alerts.
- When performing any work on a vehicle, it is good practice to connect it to BUDS2 to ensure that all needed updates are done.



PROBLEM



The front wheel assembly may not have been performed properly (torque application and installation of the red locking clip). In some situations, this could result in a wheel loss, increasing the risk of a crash.

SOLUTION

Retorque the front wheel nuts and reinstall the red locking clip.

Fill in the *MANDATORY CERTIFICATION FORM*.

MANDATORY TOOLS

REQUIRED TOOL	
65MM SOCKET (P/N 529 036 457)	
Calibrated torque wrench ranging up to 350 N•m (258 lbf•ft).*	
* Torque wrench calibration must be performed each year.	

CORRECTIVE ACTION

Refer to *RYKER PDI BULLETIN* if needed.

Retorquing the Wheel Nuts

1. Turn the handlebar and lock the wheel hub with a locking device (such as a long Allen key or a tempered steel rod).

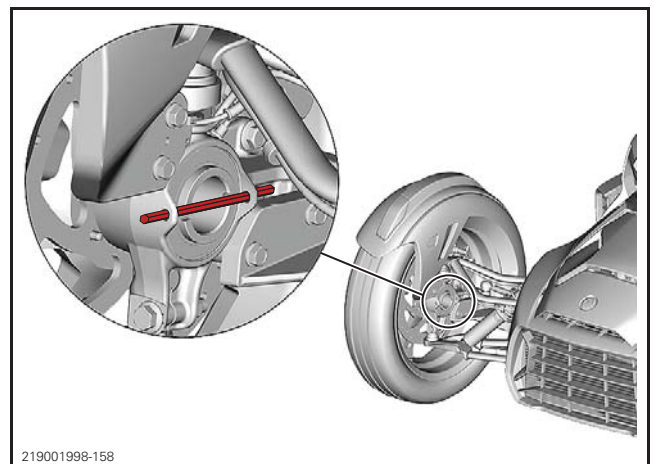

2. Remove the RED locking clip.

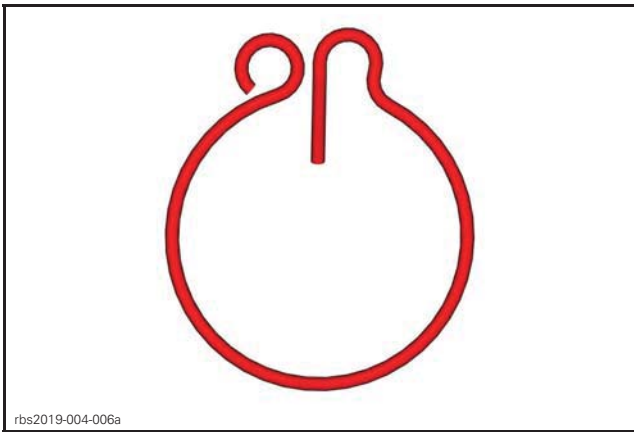

rbs2019-004-006a

3. Verify torque.

TIGHTENING TORQUE	
Center lock wheel nut	300 N•m ± 15 N•m (221 lbf•ft ± 11 lbf•ft)

NOTICE Never use impact tools to tighten wheel nuts.

IMPORTANT

If the wheel nut was NOT properly torqued and the wheel assembly is found to be loose, it will be necessary to validate that the wheel assembly components are all in good condition.

In the case of damaged parts, the standard warranty guidelines apply.

Installing the Red Locking Clip

1. Reinstall the red locking clip.
2. RED locking clip installation is **Mandatory**
The folded end must point inside the drive axle.

A properly installed red locking clip is sitting well into the groove all around the nut.

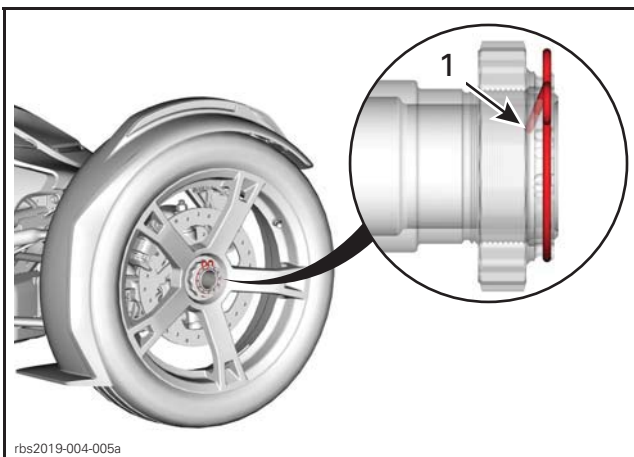

rbs2019-004-005a

1. Folded end pointing inside the drive axle

NOTICE Never untighten the nut to align the RED locking clip hole. Tighten the nut to the nominal value, then tighten further to align the hole.

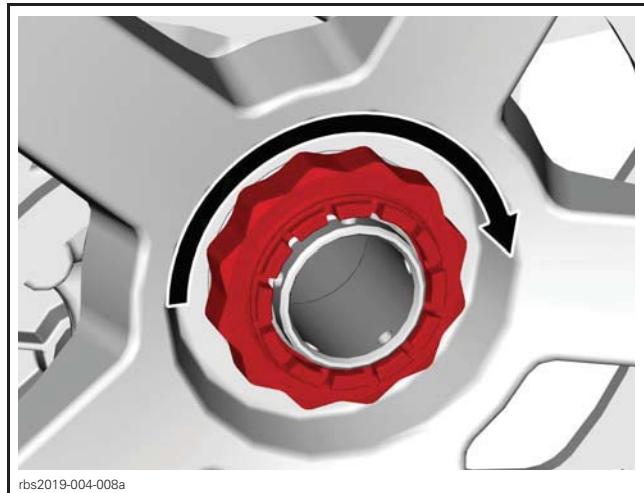

rbs2019-004-008a

3. Remove locking device from the wheel hub.

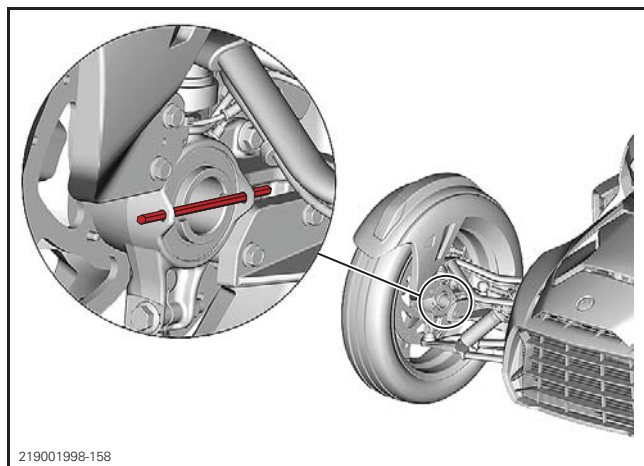

219001998-158

WARNING

Failure to install the RED locking clip may cause the loss of a wheel if the center lock wheel nut becomes loose.

MANDATORY CERTIFICATION FORM

This form MUST be signed by the technician who performed the procedure and by the Master technician or Service Manager as confirmation that the service was performed as per BRP's required procedure.

It MUST be signed by the customer.

A copy of the form must be given to the customer.

Dealership must keep his copy in the vehicle's file as proof.

Mandatory Certification of Front Wheels Installation		
Brand CAN-AM	Model Ryker	Vehicle Identification Number
I certify that the front wheels of this vehicle were installed as per BRP's required procedures.		
Technician's signature	Technician's PRINT NAME	Date
Master Technician's signature or Service Manager	Master Technician's signature or Service Manager PRINT NAME	Date
BRP or any government authority may ask for this document at anytime. Dealership must KEEP this in the vehicle's file.		
Customer's signature	Customer's PRINT NAME	Date
I confirm that I have received a copy of this CARD from the dealer.		
rbg2019-011-101		

A TEMPLATE OF THE FORM IS PROVIDED WITH THIS BULLETIN.

WARRANTY

Submit a warranty claim using the following information.

For claiming procedure, refer to the *DEALER/DISTRIBUTOR WARRANTY GUIDE*.

Product Line	Ryker
Unit Model Year	2020
Campaign/Bulletin/Description	8 / 2020-6 / Ryker Wheel Nut and Clip
*Action	
Inspect	Repair
<input checked="" type="checkbox"/>	<input type="checkbox"/>
Total Labor time paid	0.3 hour