

# Product Safety Recall

## N192285070 Tonneau Cover Retention



**Release Date:** September 2020

**Revision:** 01

**Revision Description:** This bulletin has been revised to update the Warranty Information and Preliminary Inspection sections to provide dealers with an inspection labor code option to use in combination with the Dealer Disclosure Form. Please discard all previous copies of N192285070.

**Attention:** It is a violation of Federal law for a dealer to deliver a new motor vehicle or any new or used item of motor vehicle equipment (including a tire) covered by this notification under a sale or lease until the defect or noncompliance is remedied.

This recall involves hard tri-fold tonneau covers sold as a dealer-installed option and sold over-the-counter as a dealer accessory. Please see the “Various vehicles” section of this bulletin for details.

Vehicles involved in this recall were placed on stop delivery April 16, 2020. Once the service procedure contained in this bulletin has been performed on the vehicle, the vehicle is released from stop delivery and the vehicle can be delivered to the customer.

All involved vehicles that are in dealer inventory must be held and not delivered to customers, dealer traded, or used for demonstration purposes until the repair contained in this bulletin has been performed on the vehicle.

**Dealer Notification Instructions.** Because this is an equipment recall, dealers must search their sales records for over-the-counter sales and provide the recall notice to the purchaser. For recalled equipment sold as a dealer-installed option; these VINs will be available on the Investigate Vehicle History (IVH) screen in GM Global Warranty Management (GWM) system and GM will contact these customers.

**Please search your part-sales records for over-the-counter sales of the recalled equipment (short box 84060328 & 84679033; long box 84060327 & 84679034) and send the owner of record the recall notice attached to this bulletin by first-class mail.** If the purchaser is a body shop, independent repair shop, or other third-party automotive repair or distribution business, dealers are to contact the entity, obtain the owner's name and address, and send the owner a copy of the letter.

For some over-the-counter sales, GM's records contain the vehicle's VIN. For these vehicles, GM has prepared a report that contains the VINs, customer names, and associated address information, and has provided it to dealers through the GM GlobalConnect Recall Reports. A dealer will not have a report available if it has no involved vehicles currently assigned. The listing may contain customer names and addresses obtained from motor vehicle registration records. **The use of such motor vehicle registration data for any purpose other than follow-up necessary to complete this recall is a violation of law in several states/provinces/countries. Only use this report to conduct the recall-related notifications specified in this bulletin and required by law.**

Make	Model	Model Year		RPO	Description
		From	To		
Chevrolet	Silverado 1500 LD (New Model)	2019	2019	VOZ	Accessory-Tonneau - Rr Compt - Hard Folding - Alt Design <b>Excludes CarbonPro Trim</b> <b>Excludes Parts 84786353 &amp; 84786354</b>
	Silverado 1500 LD	2020	2020		
GMC	Sierra 1500 LD (New Model)	2019	2019		
	Sierra 1500 LD	2020	2020		

Involved vehicles are marked “open” on the Investigate Vehicle History screen in GM Global Warranty Management system. This site should always be checked to confirm vehicle involvement prior to beginning any required inspections and/or repairs.

# Product Safety Recall

## N192285070 Tonneau Cover Retention



<b>Condition</b>	General Motors has decided that a defect, which relates to motor vehicle safety, exists in certain tri-fold tonneau covers sold as accessories for 2019 – 2020 model year Chevrolet Silverado and GMC Sierra 1500 series trucks. The tonneau cover may become loose and could detach from the pickup bed while driving. <b>This recall includes all of the tri-fold tonneau covers previously subject to equipment recall 19E031 (N192217500).</b> If the tonneau cover is improperly installed, owners may notice noise coming from the cover, damage to cover attachments, or cover movement against the truck's bed rails. The tonneau cover's attachment system may not sufficiently secure the tonneau cover to the truck bed rails if the attachment system is damaged or improperly installed, or if the recall repair in equipment recall 19E031 (N192217500) was improperly performed. If the tonneau cover detaches from a moving vehicle and falls into a roadway, it may increase the risk of a crash.
<b>Correction</b>	Dealers will replace the tonneau rails and clamps and add a tether to prevent the tonneau from detaching onto the roadway even if improperly installed. If the vehicle was covered by equipment recall 19E031 (N192217500), the dealer will also confirm that the repair for equipment recall 19E031 (N192217500) was correctly performed.

### Parts

Quantity	Part Name	Part No.
1	CLAMP KIT-P/U BOX CVR SHORT BOX	84962250
1	CLAMP KIT-P/U BOX CVR STANDARD BOX	84962251
If Req.	*ATTACHMENT KIT-P/U BOX REAR TOP	84767027

\* Only required if recall N192217500 has not been performed.

**Reminder:** Parts may be removed from Retail Inventory Management (RIM). Dealers should review the affected parts to confirm RIM managed status. Parts may have quantity limiters in effect.

### Warranty Information

For vehicles that are listed in IVH				
Labor Operation	Description	Labor Time	Trans. Type	Net Item
9105295	Inspection - Including Requested No Hard Tri-fold Tonneau Cover/No Cover Package Installed <b>Important: Dealer Disclosure Form attached at the end of this bulletin must be completed and retained with your repair order / job card when using this labor code.</b>	0.2	ZFAT	*
9105172	Verified Updated Cover – No further Action Required.	0.2	ZFAT	N/A
9105173	Install Pickup Box Cover Clamp Kit ADD: Adjust Latches ADD: Install Additional Components from Recall N192217500 Kit	0.9 0.2 0.8	ZFAT	N/A
9105174	Customer Reimbursement Approved - For USA and Canada dealers only	- N/A	ZFAT	***
9105175	Customer Reimbursement Denied – For USA dealers only	N/A	ZFAT	****
9105176	Floor Plan Reimbursement – NEW INVENTORY ONLY	N/A	ZFAT	****

For vehicles that are NOT listed in IVH				
Labor Operation	Description	Labor Time	Trans. Type	Net Item
9105177 **	Verified Updated Cover – No further Action Required.	0.2	ZREG	N/A
9105178 **	Install Pickup Box Cover Clamp Kit ADD: Adjust Latches ADD: Install Additional Components from Recall N192217500 Kit	0.9 0.2 0.8	ZREG	N/A
9105179 **	Customer Reimbursement Approved - For USA and Canada dealers only	- N/A	ZREG	***
9105180 **	Customer Reimbursement Denied – For USA dealers only	N/A	ZREG	****

\* Use for all inspections, including inspection of the vehicle for no signs of subject recalled tonneau cover for customers who no longer want the tonneau cover installed. Use the appropriate reimbursement code in conjunction with this inspection code where applicable. Refer to instructions in the Preliminary Inspection section for further information.

\*\* Because the VIN is not loaded into IVH, the warranty transaction MUST be H-routed for wholesale authorization.

# Product Safety Recall

## N192285070 Tonneau Cover Retention



\*\*\* For USA and Canada: Submit the dollar amount reimbursed to the customer in Net/Reimbursement. Submit \$20.00 administrative allowance in Net/Admin Allowance.

\*\*\*\* Submit \$10.00 administrative allowance in Net/Admin Allowance.

### Floor Plan Reimbursement – NEW INVENTORY ONLY

\*\*\*\*\* **USA & Canada Only** – For vehicles eligible for floor plan reimbursement, the amount should be submitted in Net Item/Miscellaneous. This amount should represent the product of the vehicle’s average daily interest rate (see table below) multiplied by the actual number of days the vehicle was in dealer inventory and not available for sale. This reimbursement is limited to the number of days from the date of the stop delivery message (April 16, 2020) to the date the repair is completed, and the vehicle is ready for sale (not to exceed 71 days):

Vehicle	Floor Plan Reimbursement Amount	
	USA	Canada
2019 Chevrolet Silverado 1500 (New Model) Crew	\$5.57	\$8.63
2019 Chevrolet Silverado 1500 (New Model) EXT	\$5.57	\$7.13
2020 Chevrolet Silverado 1500 Crew	\$5.61	\$8.73
2020 Chevrolet Silverado 1500 EXT	\$5.61	\$7.94
2019 GMC Sierra 1500 (New Model) Crew	\$6.57	\$8.09
2019 GMC Sierra 1500 (New Model) EXT	\$6.57	\$7.39
2020 GMC Sierra 1500 Crew	\$6.61	\$9.78
2020 GMC Sierra 1500 EXT	\$6.61	\$8.24

### Preliminary Inspection

**NOTE:** For dealers who have a signed Dealership Disclosure Statement form (attached at the end of this bulletin) that the dealer has confirmation through dealer records or from the customer that the customer did not receive a tonneau cover subject to this safety recall at vehicle delivery, or that the customer has permanently disposed of (scrapped, thrown away, etc) the tonneau cover subject to this recall; use labor code 9105295 inspection – No hard tri-fold tonneau cover/No cover package installed to close the VIN. The dealer is to also use labor code 9105174 to reimburse the customer for the hard tri-fold tonneau cover (previously removed before customer took delivery). If the original **UNWANTED** hard tri-fold tonneau cover is still in dealer’s possession and **NEW** in the box, the tonneau cover **MUST** be inspected and updated per the procedure in this bulletin. Once the cover is updated per the terms of this bulletin, it can be reused and sold to a customer. If the original **UNWANTED** hard tri-fold tonneau cover was installed in any way and removed, or has been stored outside of original box, it should be scrapped.

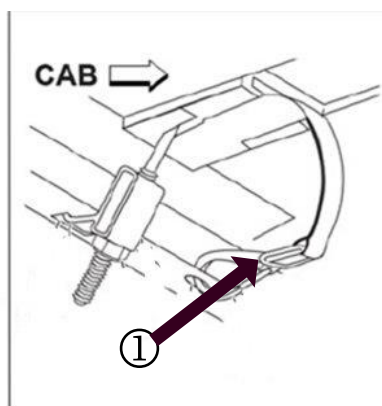

5613815

Open the front section of the tonneau cover and locate the outboard ends of the front hinge track. If the cover already has tethers (1) installed, it is up to date and no further action is required.

### Service Procedure

**Caution:** Use the correct fastener in the correct location. Replacement fasteners must be the correct part number for that application. Fasteners requiring replacement or fasteners requiring the use of thread locking compound or sealant are identified in the service procedure. Do not use paints, lubricants, or corrosion inhibitors on fasteners or fastener joint

# Product Safety Recall

## N192285070 Tonneau Cover Retention



surfaces unless specified. These coatings affect fastener torque and joint clamping force and may damage the fastener. Use the correct tightening sequence and specifications when installing fasteners in order to avoid damage to parts and systems.

1. Open tonneau cover. Fold the sections and clip the tiedown straps.
2. Loosen clamp bolt and disengage the clamp from the pickup box.
3. Repeat for opposite side.
4. Remove the folded tonneau cover from the vehicle. Carefully flip the cover assembly and place it on the work surface with the front hinge track facing up.

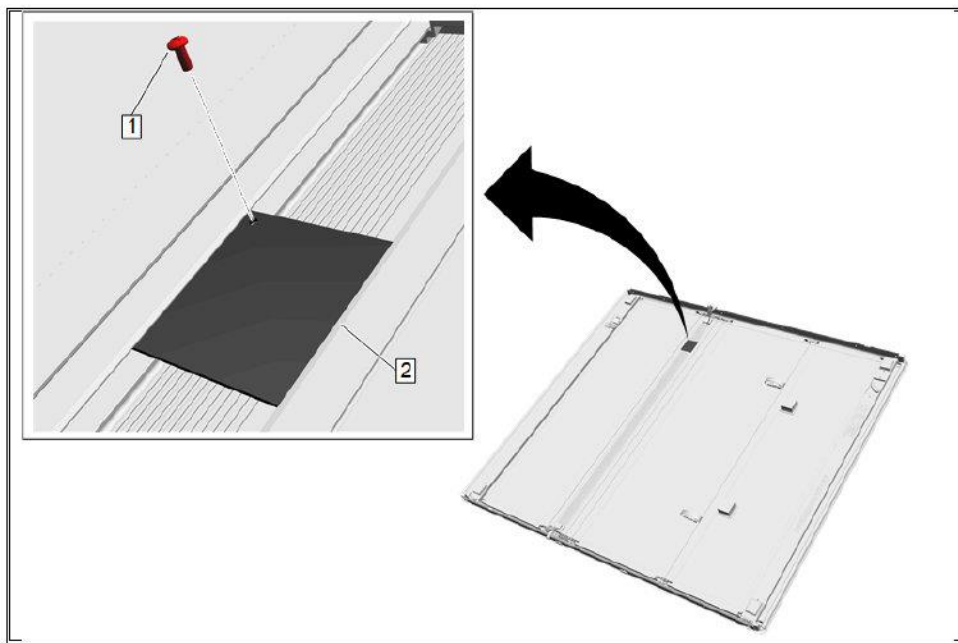

5609953

5. Remove the screw (1) from the hinge plate cover (2), retain the screw.

**Product Safety Recall**  
N192285070 Tonneau Cover Retention

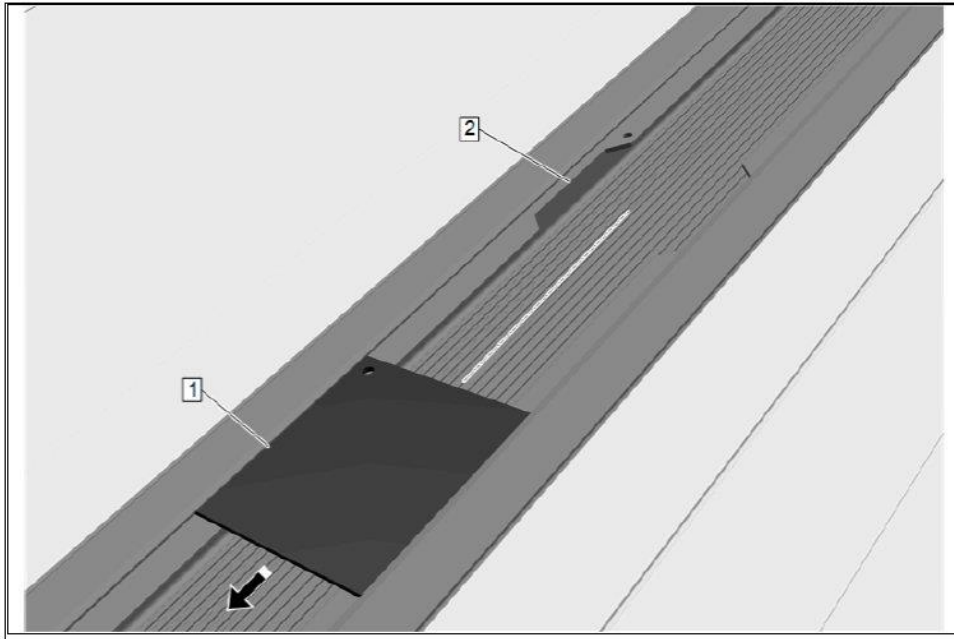

5609957

6. Slide the hinge plate cover (1) toward the center of the panel to expose the hinge cutout opening (2).

# Product Safety Recall

## N192285070 Tonneau Cover Retention

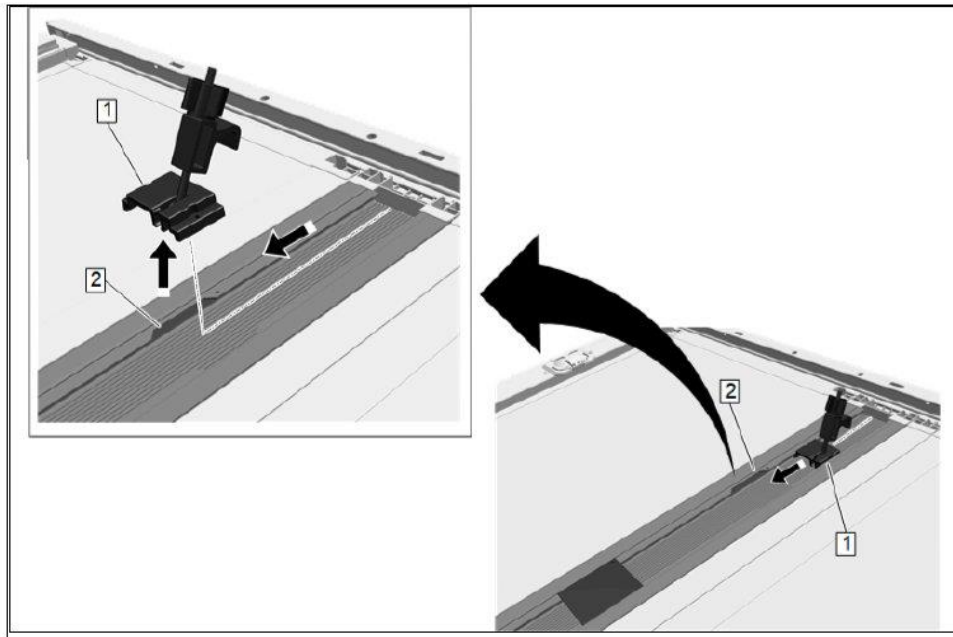

5609962

7. Slide the existing clamp bolt assembly (1) out of the cutout (2). Discard the clamp bolt assembly, it will not be reused.
8. Repeat step 7 for opposite side.

# Product Safety Recall

## N192285070 Tonneau Cover Retention

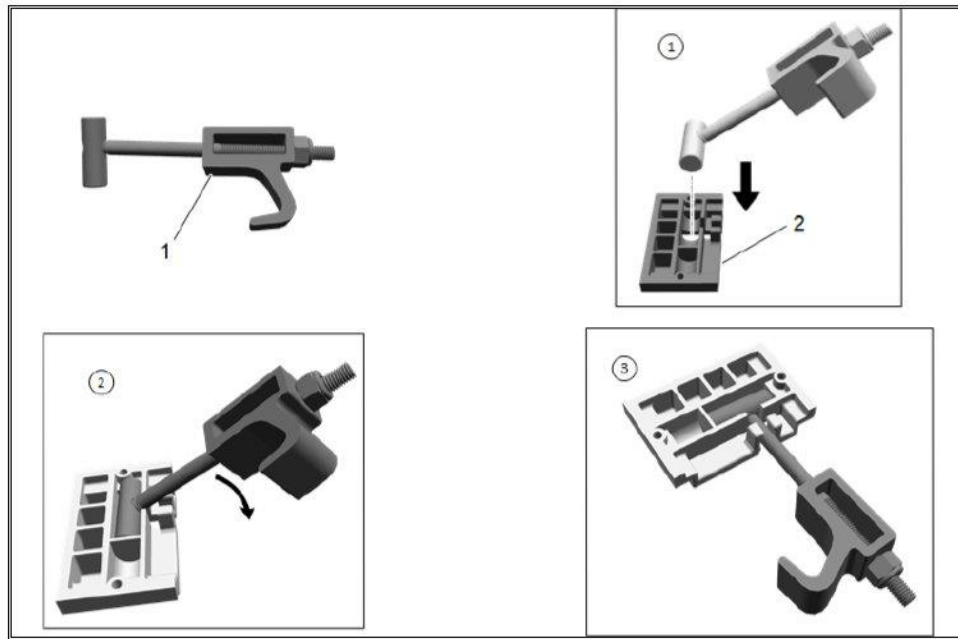

5609963

**Note:** Follow sequence (1-3) in graphic as shown.

9. Locate the new clamp bolt assembly (1) and new slide plate (2). Snap barrel of clamp bolt into slide plate.

# Product Safety Recall

## N192285070 Tonneau Cover Retention

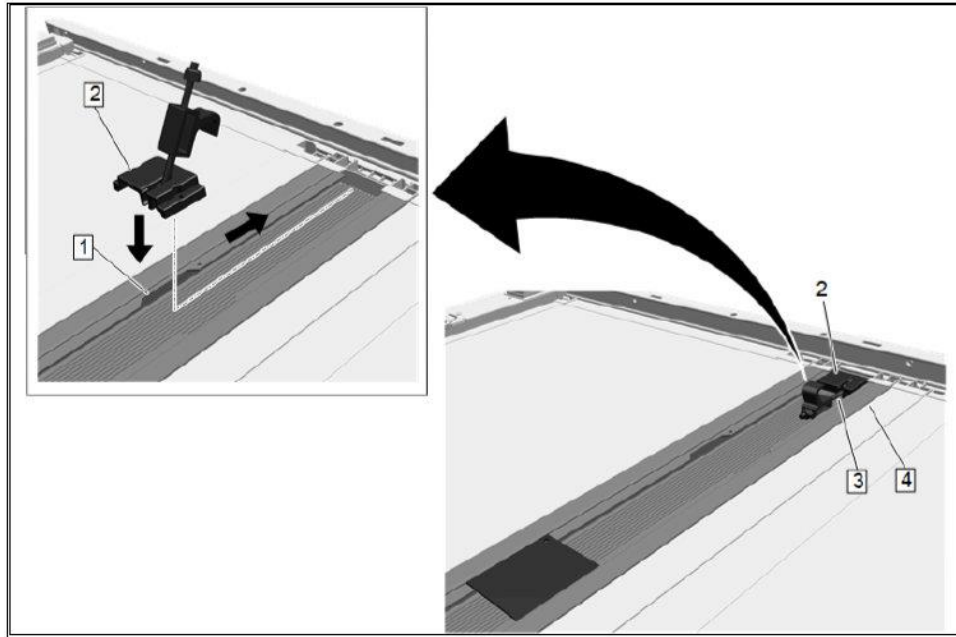

5609964

10. Install the new clamp bolt assembly (2) through the cutout (1) and slide outboard.
11. Push the clamp bolt down into the hinge plate.
12. Verify the clamp bolt stud (3) is offset toward the folded edge of the hinge plate (4).
13. Repeat steps 9-12 for the opposite side.



# Product Safety Recall

## N192285070 Tonneau Cover Retention

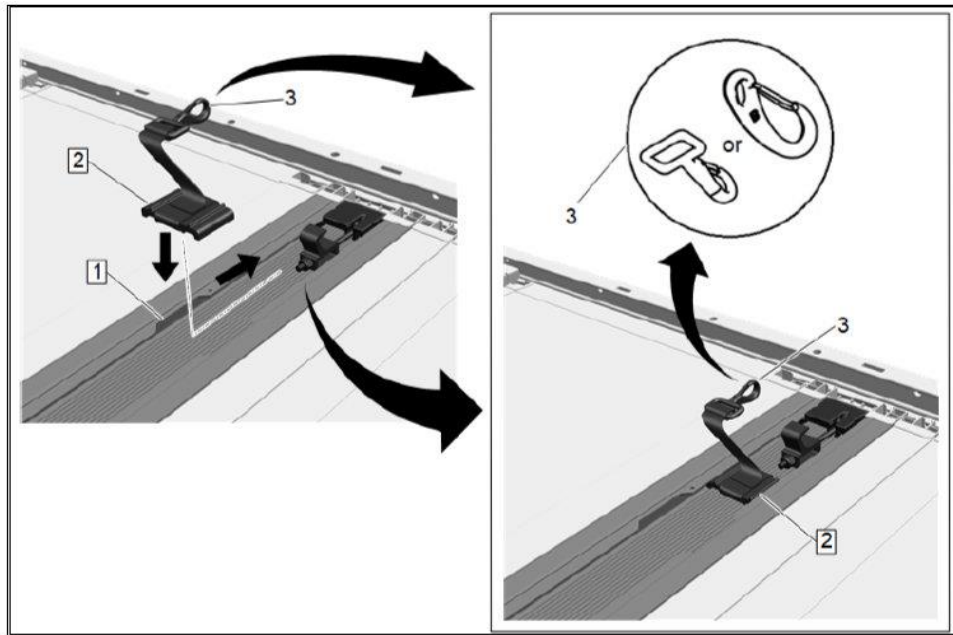

5609965

**Note:** Hook style may vary.

14. Hold the tether assembly (2) over the hinge plate cutout (1) and verify the hook (3) is positioned outboard of the mounting plate and the hook clasp is facing away from the channel.
15. Install the tether plate portion of the tether assembly (2) into the cutout (1) of the hinge plate. Slide the tether assembly to the outboard side.
16. Repeat steps 14-15 for the opposite side.

## Product Safety Recall N192285070 Tonneau Cover Retention

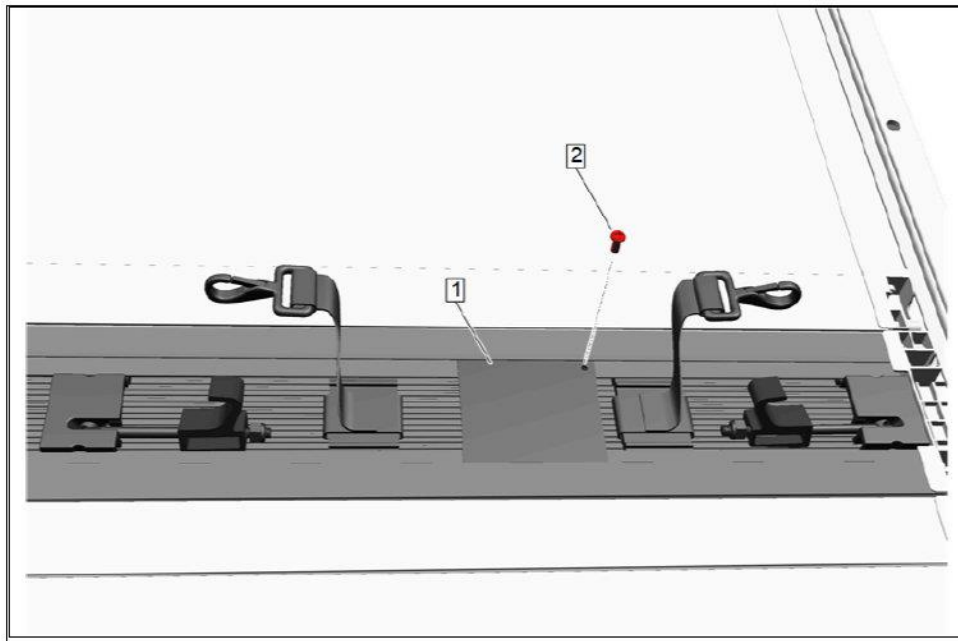

5609967

17. Position the hinge plate cover (1) in the track over the cutout.
18. Reinstall screw (2) previously removed from step 5.
19. Tape new owner's manual to the B surface of the tonneau cover.
20. Remove side rails from the pickup box by removing the T30 torx screws.

# Product Safety Recall

## N192285070 Tonneau Cover Retention

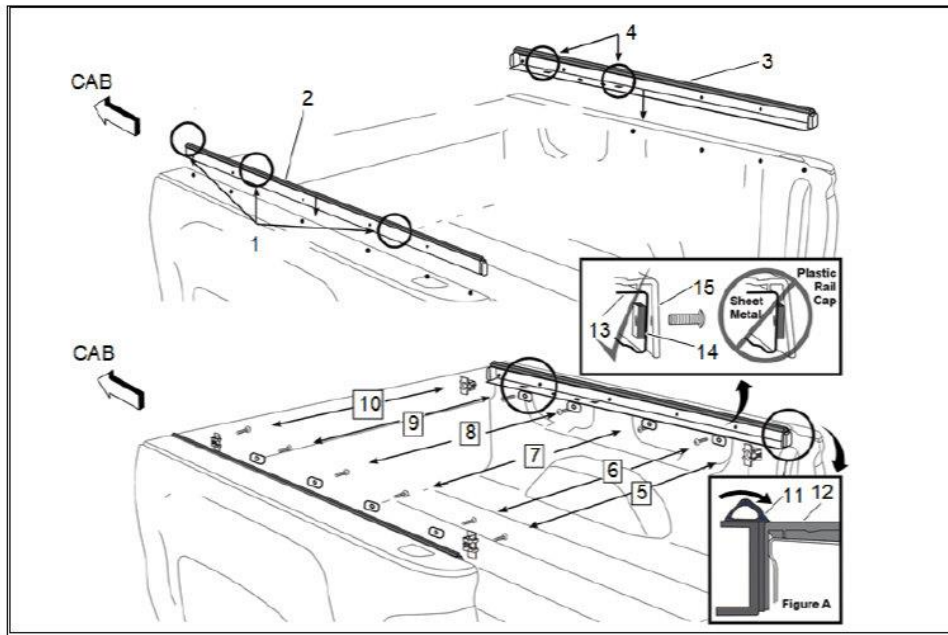

5609968

**Note:** If vehicle is equipped with power end gate refer to **For Power Open and Close End Gate Only** section at the end of these instructions.

**Note:** Driver side rail (1) has three notches, passenger side rail (3) has two notches (4).

**Note:** Backing plates (14) are installed on the back side of the sheet metal (13). **DO NOT** install backing plates between plastic trim caps (15) and sheet metal.

21. Install driver side rail (1) in the order shown using Loctite 272 on screws prior to installing. Hand tighten attachment bolt (5) and (10) in box nuts. Hand tighten (6), (7), (8) and (9) into backing plates. Align the edge of the rail seal (11) with the top of the plastic trim cap (12) as shown in figure A. Use T30 torx to fully tighten the bolts (6), (7), (8) and (9) followed by bolts (5) and (10) to 8.7 Nm (6.4 lb ft). Repeat for passenger side rail (3).
22. Position tonneau cover onto the front on the pickup box.

# Product Safety Recall

## N192285070 Tonneau Cover Retention

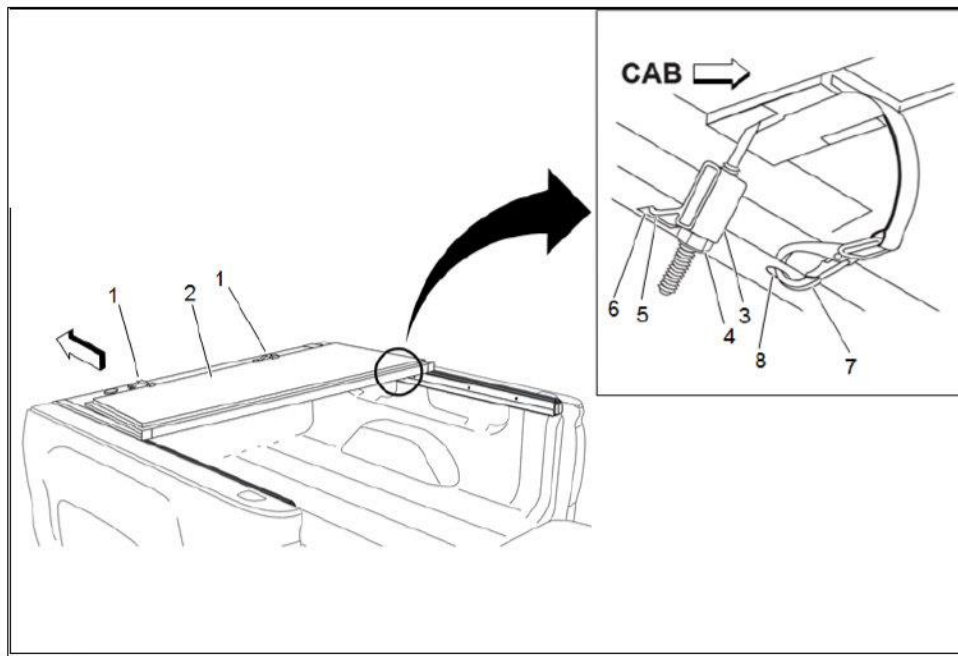

5609969

23. Locate the rectangular notch (6) in the driver and passenger side rails that align with the clamps. Align the stationary clamps (3) to the rectangular notch (6). Position the cover (2) evenly side to side and rest the cab seal smoothly along the cab wall of the bed. Position the stationary clamps (3) so that the hook (5) rests inside the rectangular notch (6) in the rail. Tighten the nut (4). Be sure to tighten each side evenly. Tighten only until tonneau cannot shift from its position. **DO NOT OVER TIGHTEN.** Over tightening of nut (4) can cause failure to clamping system. Be sure to clip safety tether (7) to hole (8) in rail from top down for ease of removal.

**Note:** The end gate must be open when closing tonneau cover (2).

24. Unclip the tie down straps (1) and unfold the tonneau (2).

**Product Safety Recall**  
N192285070 Tonneau Cover Retention



**Adjustment Instructions for Vehicles That Have Had Recall N192217500 performed.**



5368725

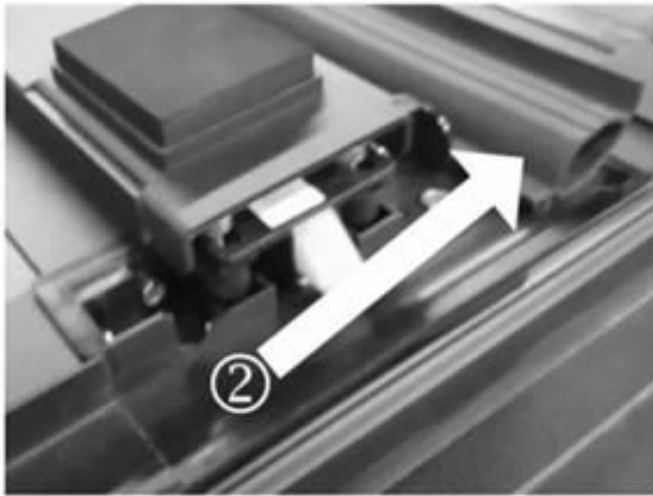

5368719

**Important:** Verify the front tonneau cover seal is the revised “fin” style seal (1). If the “bulb” style seal is installed (2), replace the seal. Refer to steps 1-5 of the Adjustment Instructions for Vehicles That Have NOT Had Recall N192217500 performed below.

# Product Safety Recall

## N192285070 Tonneau Cover Retention

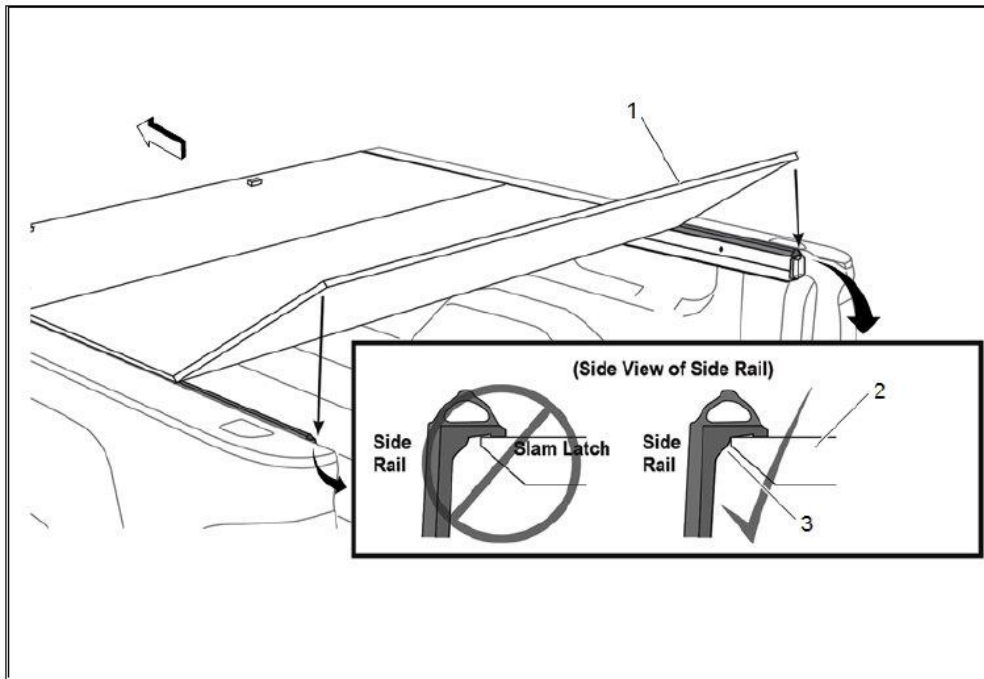

5609971

1. With both hands, press down on the rear bar (1) until the rear slam latches (2) engage driver side and passenger side rails (3).
2. Lift the forward panel to 30°. Drop the forward panel to engage the driver side and passenger side slam latches (2).

# Product Safety Recall

## N192285070 Tonneau Cover Retention

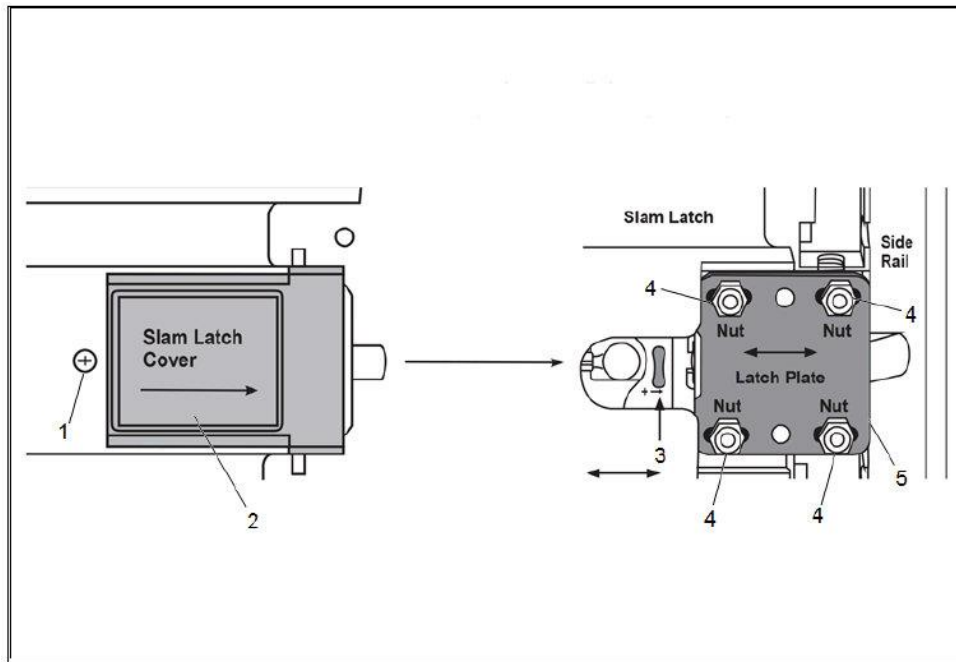

5609975

3. If the slam latches do not engage or there is excessive slack in the latches, adjust latches in or out and up or down. To adjust, remove the screw (1) from the slam latch cover (2) and side cover off. Loosen the four nuts (4) to move the latches in or out, move the metal latch plate. To move the latches up or down, move the plastic adjuster tab (3). Tighten the four nuts. Repeat steps 1 and 2.

# Product Safety Recall

## N192285070 Tonneau Cover Retention



For Power Open and Close End Gate Only

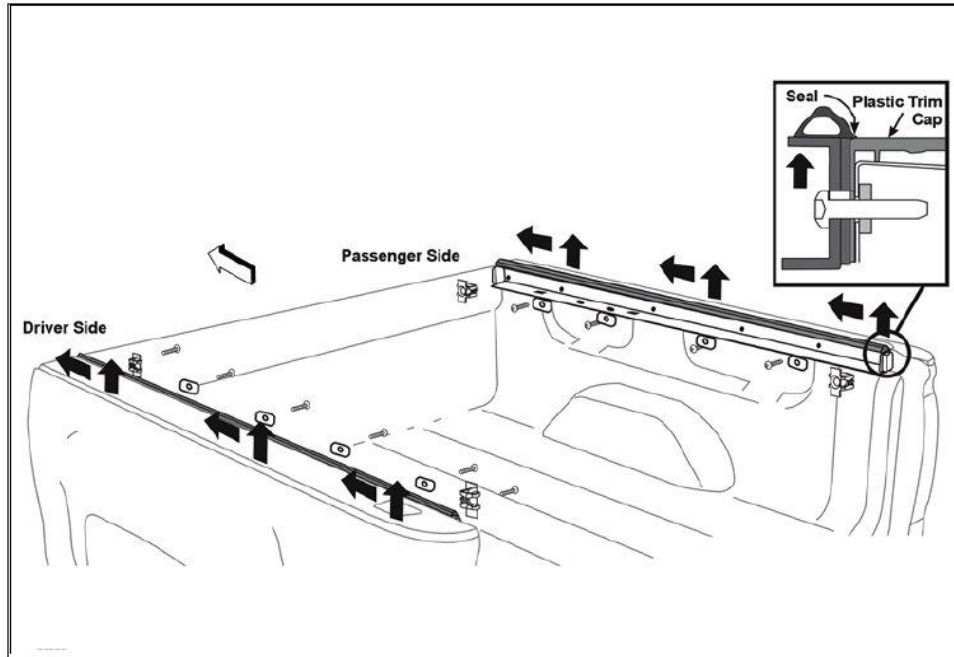

5609977

**Note:** Tonneau cover side rails must be adjusted to full up position and cover assembly must be adjusted to full forward position to ensure proper powered end gate closure to fully latched position.

**During Step 21:** While tightening each bolt to attach the rails, pull up and forward on the rails. Refer to Step 21 for bolt tightening sequence. Cycle the power end gate no less than 5 times to assure proper function.

**Adjustment Instructions for Vehicles That Have NOT Had Recall N192217500 performed.**



5331766

1. Open the front panel (closest to the cab) of the tonneau cover and lay it flat.



# Product Safety Recall

## N192285070 Tonneau Cover Retention

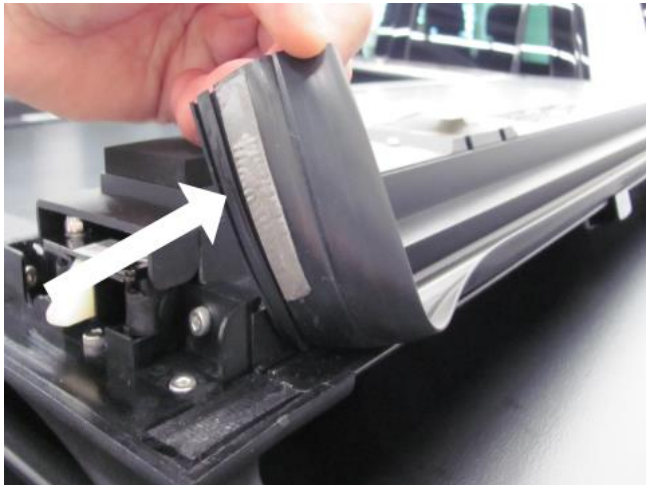

5331768

2. Locate the outboard ends of the front seal. Peel the seal loose at both ends. With the adhesive ends released, slide the front seal out of the channel. Discard the seal.

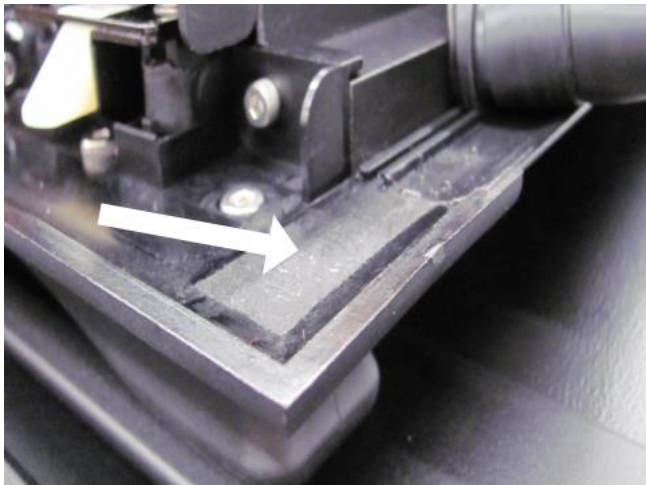

5331770

3. Remove any residual double-sided tape and adhesive from the end caps using a general-purpose adhesive remover.

**Note:** Apply a light coating of glass cleaner to the first 60cm. (2 ft.) of the seal. This will act as a lubricant allowing the seal to easily slide into the channel.

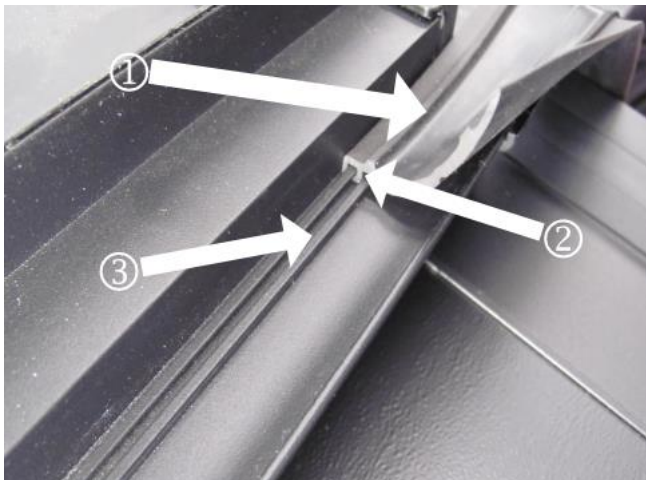

5331771

4. Install the new front lip seal (1), ensure the seal anchor (2) mates with the extrusion channel (3). Slide the seal across the full length of the channel, **ensure seal is centered** on the front panel.

# Product Safety Recall

## N192285070 Tonneau Cover Retention



5. Locate the double-sided tape at both outer ends of the new seal. Remove the protective film and press the seal (2) firmly onto the corner cap (1), apply pressure for 15 seconds to allow the adhesive to bond. Perform this step on both ends of the new seal.

**Note:** Perform the following steps on both the left and right front latch assemblies.

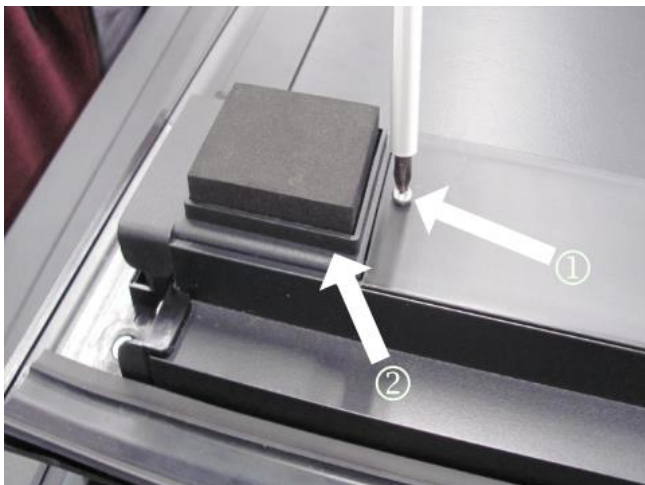

6. Locate the latches on the open front panel. Remove the screw (1) and slide the plastic closeout cover out (2).

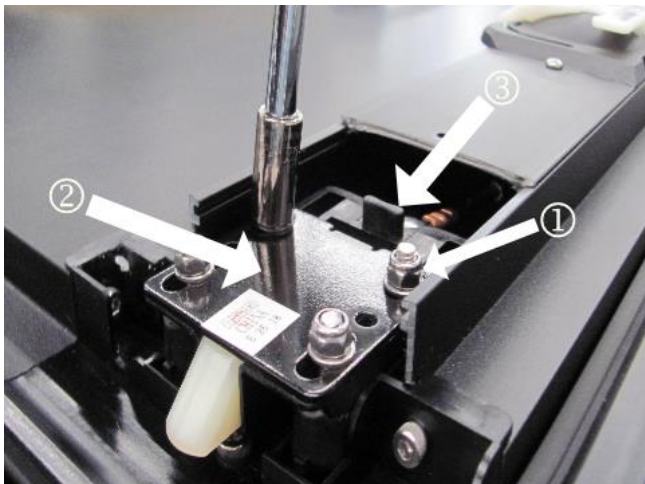

7. Remove the 4 nuts and 4 washers (1). Discard the nuts, retain the washers. Remove the latch plate (2) and U-shaped adjustment step (3) and set them to the side, a cable will remain attached to the latch.

# Product Safety Recall

## N192285070 Tonneau Cover Retention

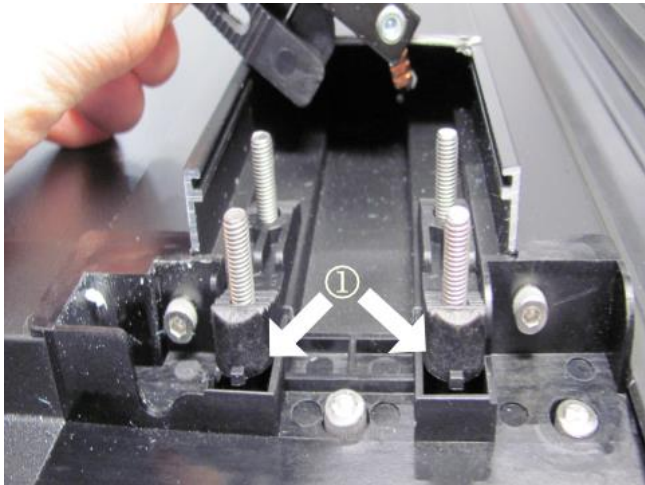

5331777

8. Remove the two existing lower adjusters and discard (1). Install the two new adjusters provided in the attachment kit.

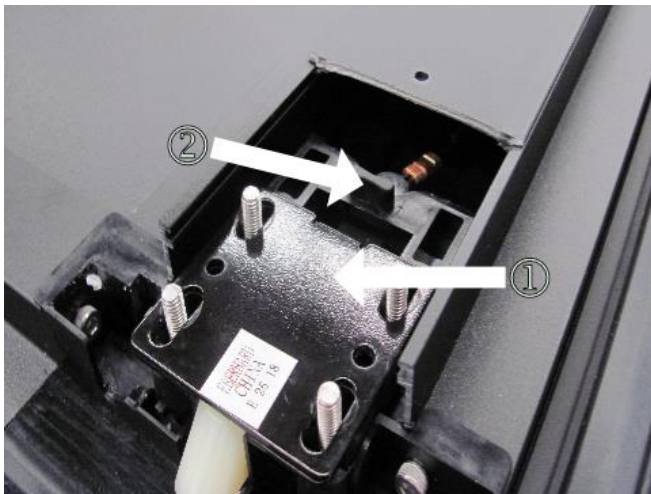

5331778

9. Reinstall the original U-shaped adjuster (2) and latch (1).

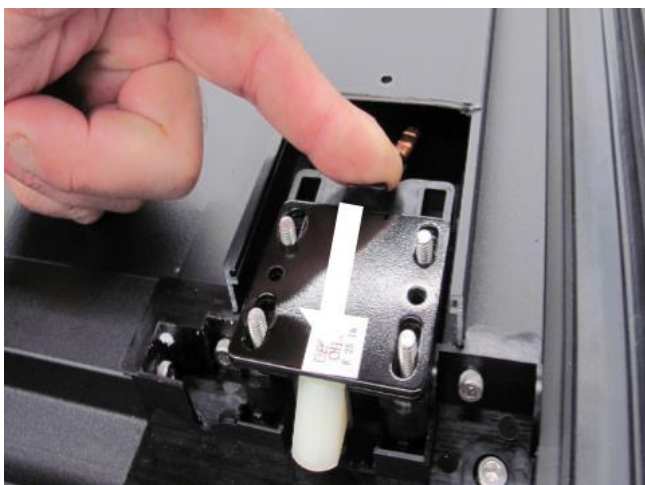

5331779

10. Set the latch to the correct (maximum) height, push on the inboard standing tab and slide the U-shaped adjuster to the full outboard position.

**Important:** Do not overtighten the fasteners or damage may occur to the top cover.

## Product Safety Recall

### N192285070 Tonneau Cover Retention

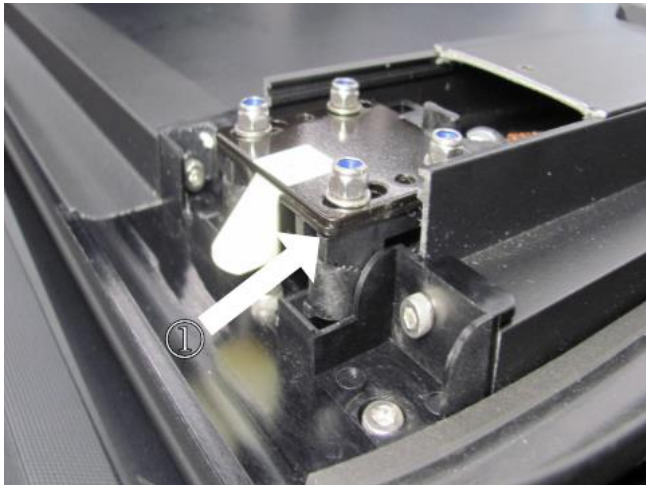

5331782

11. Loosely install the 4 original washers and the 4 new nuts supplied with the attachment kit. Align the outer edge of the latch with the edge of the plastic corner rib (1). Tighten the 4 nuts to 1Nm (9 lb.-in).

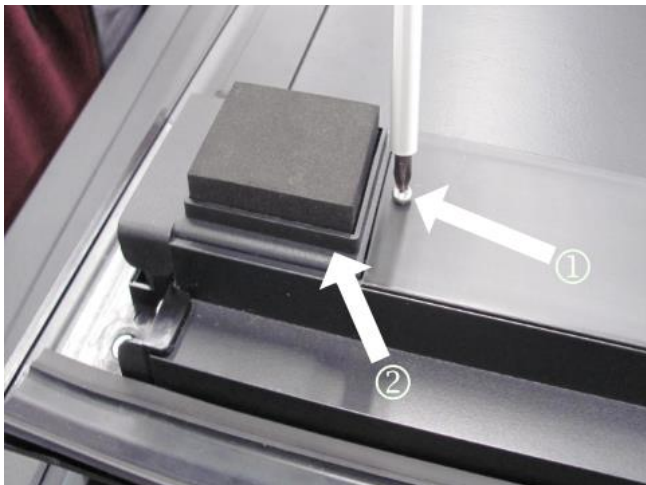

5331774

12. Slide the latch close out cover (2) into position and install the fastener (1).
13. Lift the forward panel to 30°. Drop the forward panel to engage the driver side and passenger side slam latches. Ensure the latch fully engages under the pickup box rail on both sides. Adjust as required.
14. Open the rear panel and locate the left (driver side) latch. Perform steps 6-12 at this location.  
**Important:** The right-side rear latch requires specific fitting steps to prevent interference. The following steps are specific to the right rear latch.
15. With the rear panel open, locate the right (passenger side) latch. Perform steps 6-12 at this location, **with one** exception.

## Product Safety Recall

### N192285070 Tonneau Cover Retention

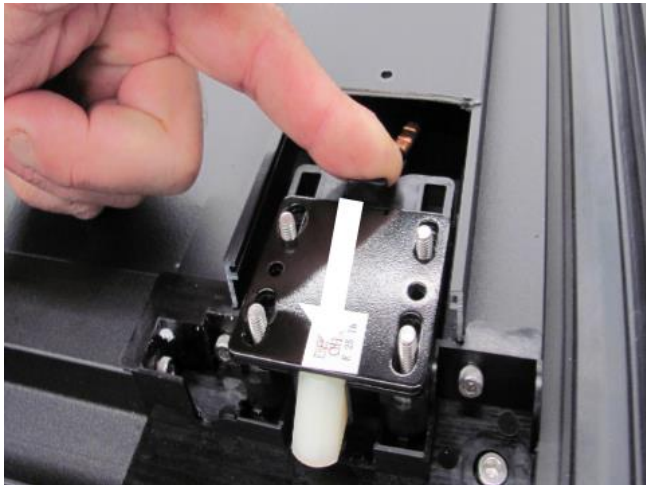

5331779

- When reinstalling the U-shaped adjustor and latch, push on the inboard standing tab and slide the U-shaped adjustor to the full outboard position.

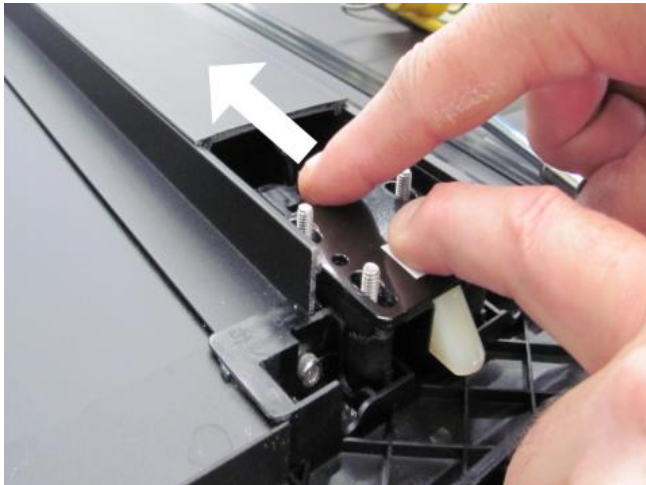

5331784

- While applying light finger pressure to the metal plate, push the adjustor inboard two steps. You should be able to feel the two steps as well as hear a “click” type sound.
- With pressure still applied to the metal plate, install the 4 existing washers along with the 4 new nuts supplied with the attachment kit. Tighten the 4 nuts to 1Nm (9 lb.-in).

# Product Safety Recall

## N192285070 Tonneau Cover Retention

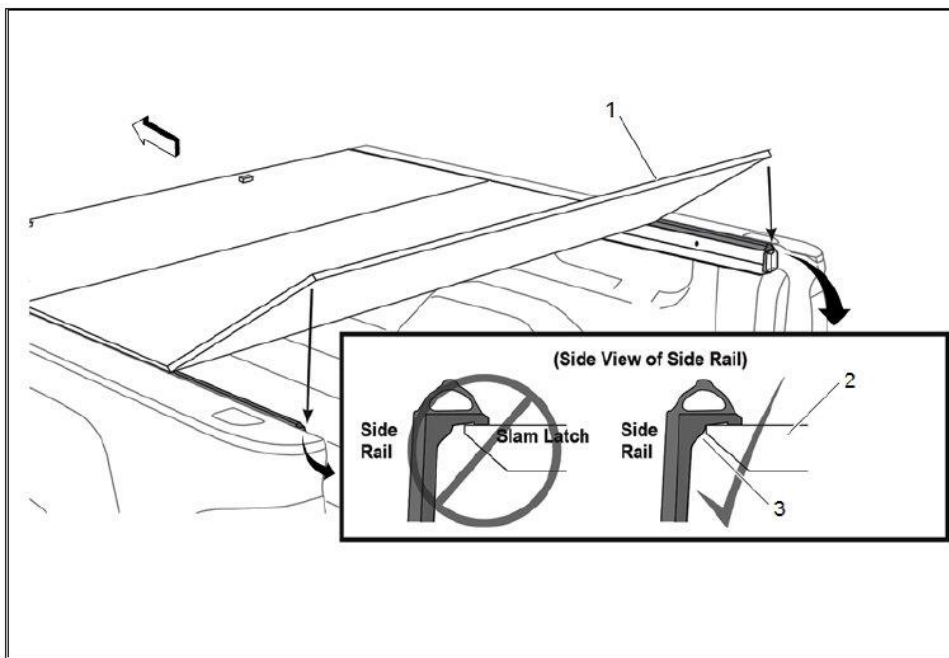

5609971

16. With both hands, press down on the rear bar (1) until the rear slam latches (2) engage driver side and passenger side rails (3). Adjust if required.

### Dealer Responsibility – For USA & Export (USA States, Territories, and Possessions)

It is a violation of Federal law for a dealer to deliver a new motor vehicle or any new or used item of motor vehicle equipment (including a tire) covered by this notification under a sale or lease until the defect or noncompliance is remedied.

The US National Traffic and Motor Vehicle Safety Act provides that each vehicle that is subject to a recall of this type must be adequately repaired within a reasonable time after the customer has tendered it for repair. A failure to repair within sixty days after tender of a vehicle is prima facie evidence of failure to repair within a reasonable time. If the condition is not adequately repaired within a reasonable time, the customer may be entitled to an identical or reasonably equivalent vehicle at no charge or to a refund of the purchase price less a reasonable allowance for depreciation. To avoid having to provide these burdensome remedies, every effort must be made to promptly schedule an appointment with each customer and to repair their vehicle as soon as possible. In the recall notification letters, customers are told how to contact the US National Highway Traffic Safety Administration if the recall is not completed within a reasonable time.

### Dealer Responsibility – All

All new, used, GM Certified Used, courtesy transportation vehicles, dealer shuttle vehicles, etc. in dealers' possession and subject to this recall must be held and inspected/repared per the service procedure of this bulletin before customers take possession of these vehicles. Involved vehicles must be held and not delivered to customers, dealer-traded, released to auction, used for demonstration, or any other purpose.

All GM Certified Used vehicles currently in the dealers' inventory within the Certified Pre-Owned Inventory System (CPOIS) will be de-certified and must be held and remedied per the service procedure in this bulletin. Upon submitting an accepted/paid warranty transaction in the Global Warranty Management (GWM) system, the vehicle can be re-certified for sale within the CPOIS system, or once again be used in the CTP program.

Dealers are to service all vehicles subject to this recall at no charge to customers, regardless of mileage, age of vehicle, or ownership, from this time forward.

# Product Safety Recall

## N192285070 Tonneau Cover Retention



Customers who have recently purchased vehicles sold from your vehicle inventory, and for which there is no customer information indicated on the dealer listing, are to be contacted by the dealer. Arrangements are to be made to make the required correction according to the instructions contained in this bulletin. A copy of the customer letter is provided in this bulletin for your use in contacting customers. Recall follow-up cards should not be used for this purpose, since the customer may not as yet have received the notification letter.

In summary, whenever a vehicle subject to this field action enters your vehicle inventory you must take the steps necessary to ensure the program correction has been made before selling the vehicle. In addition, for vehicles entering your facility for service, you are required to ensure the customer is aware of the open field action and make every reasonable effort to implement the program correction as set forth in this bulletin prior to releasing the vehicle.

### Dealer Reports

For dealers with involved vehicles, a listing with involved vehicles has been prepared and will be provided to U.S. and Canadian dealers through the GM GlobalConnect Recall Reports or sent directly to export dealers. The listing may contain customer names and addresses obtained from Motor Vehicle Registration Records. The use of such motor vehicle registration data for any purpose other than follow-up necessary to complete this recall is a violation of law in several states/provinces/countries. Accordingly, you are urged to limit the use of this report to the follow-up necessary to complete this recall.

### Courtesy Transportation – For USA & Canada

Courtesy transportation is available for customers whose vehicles are involved in a product program and still within the warranty coverage period. See General Motors Service Policies and Procedures Manual for courtesy transportation program details.

### Customer Notification

USA & Canada – For dealer-installed accessory sales, General Motors will notify customers of this recall on their vehicle (see copy of customer letter included with this bulletin). For dealer over-the-counter sales, GM dealers will notify customers based on dealer sales-record data.

### Customer Reimbursement

The completed form and required documents must be presented to your dealer or received by the Reimbursement Department by July 31, 2021, unless state law specifies a longer reimbursement period.

See General Motors Service Policies and Procedures Manual, Product Field Action Customer Reimbursement Procedure (USA & Canada) or local Policies and Procedures, for details.

---

GM bulletins are intended for use by professional technicians, NOT a "do-it-yourselfer". They are written to inform these technicians of conditions that may occur on some vehicles, or to provide information that could assist in the proper service of a vehicle. Properly trained technicians have the tools, equipment, safety instructions, and know-how to do a job properly and safely. If a condition is described, **DO NOT** assume that the bulletin applies to your vehicle, or that your vehicle will have that condition. See your dealer for information on whether your vehicle may benefit from the information.



**We Support  
Voluntary Technician  
Certification**

# Product Safety Recall

## N192285070 Tonneau Cover Retention



### Dealership Disclosure Statement Safety Recall N192285070 – Tonneau Cover Retention

General Motors added labor operation 9105295 – “Inspection - Including Requested No Hard Tri-fold Tonneau Cover/No Cover Package Installed” to safety recall N192285070 – Tonneau Cover Retention. **This code should only be used if you have confirmation through dealer records or from the customer that the customer did not receive a tonneau cover subject to this safety recall at vehicle delivery or that the customer has permanently disposed of (scrapped, thrown away, etc) the tonneau cover subject to this safety recall.** Tonneau Covers subject to this safety recall are part numbers 84060328 & 84679033 (short box) and part numbers 84060327 & 84679034 (long box).

*Please place a check into the appropriate box, sign and date at the bottom, and attach the original copy of this form with the repair order/job card used to submit the warranty claim.*

- The tonneau cover subject to this safety recall was never received by the vehicle owner. The owner either chose to have an alternate tonneau cover not subject to this safety recall installed before delivery or chose to accept reimbursement in lieu of a tonneau cover (RPO VOZ only). Note: if the customer chose reimbursement, labor code 9105295 – “Inspection - Including Requested No Hard Tri-fold Tonneau Cover/No Cover Package Installed” must be used in combination with labor operation 9105174 – “Customer Reimbursement Approved” to properly close the recall. *In this circumstance, if the original **UNWANTED** hard tri-fold tonneau cover is still in your possession and **NEW** in the box, the tonneau cover **MUST** be inspected and updated per the procedure in the recall bulletin. Once the cover is updated per the terms of the bulletin, it can be reused and sold to a customer. If the original **UNWANTED** hard tri-fold tonneau cover was installed in any way and removed, or has been stored outside of original box, it should be scrapped.*
- Current vehicle owner has confirmed that they disposed of the tonneau cover subject to this safety recall. List the owner’s description of the disposition (e.g. scrapped, destroyed, thrown away, etc.)  
\_\_\_\_\_
- New truck arrived at my dealership as part of a dealer trade with no tonneau cover installed. Vehicle will be or was sold to the first customer with no tonneau cover or promise of a tonneau cover. *In this circumstance, the dealer from whom the vehicle was received should be reminded that the original cover is still subject to the terms of the safety recall and should be repaired prior to any future use.*
- Other, please explain  
\_\_\_\_\_

Printed Name

\_\_\_\_\_

Dealership position

\_\_\_\_\_

Signature

\_\_\_\_\_

Date

\_\_\_\_\_





# IMPORTANT SAFETY RECALL

July 2020

This notice applies to your vehicle, VIN: \_\_\_\_\_

Dear General Motors Customer:

This notice is sent to you in accordance with the National Traffic and Motor Vehicle Safety Act.

General Motors has decided that a defect, which relates to motor vehicle safety, exists in certain tri-fold tonneau covers sold as accessories for 2019 – 2020 model year Chevrolet Silverado and GMC Sierra 1500 series trucks. As a result, GM is conducting a safety recall. We apologize for this inconvenience. However, we are concerned about your safety and continued satisfaction with our products.

## IMPORTANT

- Your vehicle is involved in GM safety recall N192285070.
- Schedule an appointment with your GM dealer.
- This service will be performed for you at **no charge**. You should schedule a service appointment with your GM dealer even if you believe that your vehicle has already received service for this condition. GM has updated the remedy procedure for the tri-fold tonneau covers previously subject to equipment recall 19E031 (N192217500).

### Why is your vehicle being recalled?

Our records indicate that your vehicle may have the recalled tri-fold tonneau cover. The attachment system used on the tonneau cover may not properly secure the cover to the pickup bed. The cover may become loose and possibly detach from the pickup bed while driving. If the tonneau cover becomes loose, you may notice noise coming from the cover, damage to cover attachments, or cover movement against the truck's bed rails. A tonneau cover that separates or detaches from the pickup bed while driving, can become a road hazard, increasing the risk of a crash.

### What will we do?

Your GM dealer will replace the tonneau rails and clamps and add a tether to prevent the tonneau from detaching onto the roadway. If the vehicle was covered by equipment recall 19E031, the dealer will also confirm that the repair for equipment recall 19E031 was correctly performed. This service will be performed for you at **no charge**. Because of service scheduling requirements, it is likely that your dealer will need your vehicle longer than the actual inspection and service correction time of approximately 2 hours.

### What should you do?

You should contact your GM dealer to arrange a service appointment as soon as possible.

### Did you already pay for this repair?

Even though you may have previously had repairs for this condition, you will still need to take your vehicle to your dealer for additional repairs. If you have already paid for repairs for the recall condition, please complete the enclosed reimbursement form and present it to your dealer with all required documents. Working with your dealer will expedite your request, however, if this is not convenient, you may mail the completed reimbursement form and all required documents to Reimbursement Department, PO Box 33170, Detroit, MI 48232-5170. The completed form and required documents must be presented to your dealer or received by the Reimbursement Department by July 31, 2021, unless state law specifies a longer reimbursement period.

### Do you have questions?

If you have questions or concerns that your dealer is unable to resolve, please contact the appropriate Customer Assistance Center at the number listed below.

Division	Number	Text Telephones (TTY)
----------	--------	-----------------------

# Product Safety Recall

## N192285070 Tonneau Cover Retention



Chevrolet	1-800-630-2438	1-800-833-2438
GMC	1-866-996-9463	1-800-462-8583
Puerto Rico – English	1-800-496-9992	
Puerto Rico – Español	1-800-496-9993	
Virgin Islands	1-800-496-9994	

If after contacting your dealer and the Customer Assistance Center, you are still not satisfied we have done our best to remedy this condition without charge and within a reasonable time, you may wish to write the Administrator, National Highway Traffic Safety Administration, 1200 New Jersey Avenue, SE, Washington, DC 20590, or call the toll-free Vehicle Safety Hotline at 1.888.327.4236 (TTY 1.800.424.9153), or go to <http://www.safercar.gov>. The National Highway Traffic Safety Administration Campaign ID Number for this recall is 20E024.

Federal regulation requires that any vehicle lessor receiving this recall notice must forward a copy of this notice to the lessee within ten days.

Maryann L. Combs  
Vice President  
Global Vehicle Safety

Enclosure  
GM Recall: N202305070