

Customer Satisfaction Program

N192285071 Tonneau Cover Retention



Release Date: June 2020

Revision: 00

Attention: Dealers were notified of this stop part install/sell/delivery order for the subject tonneau covers on April 16, 2020 under equipment safety recall N192285070. The equipment safety recall involves hard tri-fold tonneau covers sold as a dealer-installed option and sold over-the-counter as a dealer accessory for 1500 series LD vehicles.

This Customer Satisfaction Program is for new vehicle owners who took delivery of the subject trucks without the hard tri-fold tonneau cover installed (sold with “Notice to Customer” disclosure form). Follow the inspection procedure outlined below for the presence of updated retention components or, if previously retained by dealer, install attachment kit per service procedure below.

This program is in effect until July 31, 2022.

Make	Model	Model Year		RPO	Description
		From	To		
Chevrolet	Silverado 1500 LD (New Model)	2019	2019	VOZ	Accessory-Tonneau - Rr Compt - Hard Folding - Alt Design Excludes CarbonPro Trim Excludes Parts 84786353 & 84786354
	Silverado 1500 LD	2020	2020		
GMC	Sierra 1500 LD (New Model)	2019	2019		
	Sierra 1500 LD	2020	2020		

Involved vehicles are marked “open” on the Investigate Vehicle History screen in GM Global Warranty Management system. This site should always be checked to confirm vehicle involvement prior to beginning any required inspections and/or repairs.

Condition	As part of equipment recall N192285070, GM instructed dealers to remove recalled tri-fold tonneau covers on certain vehicles prior to delivery to the customer. GM is conducting this customer satisfaction field action to provide these customers with the improved tonneau cover system for their vehicle.
Correction	Dealers will replace the tonneau rails and clamps and add a tether to prevent the tonneau from detaching onto the roadway even if improperly installed. If the vehicle was covered by equipment recall 19E031 (N192217500), the dealer will also confirm that the repair for equipment recall 19E031 (N192217500) was correctly performed.

Parts

Quantity	Part Name	Part No.
1	CLAMP KIT-P/U BOX CVR SHORT BOX	84962250
1	CLAMP KIT-P/U BOX CVR STANDARD BOX	84962251
If Req.	*ATTACHMENT KIT-P/U BOX REAR TOP	84767027

* Only required if recall N192217500 has not been performed.

Reminder: Parts may be removed from Retail Inventory Management (RIM). Dealers should review the affected parts to confirm RIM managed status. Parts may have quantity limiters in effect.

Warranty Information

Labor Operation	Description	Labor Time	Trans. Type	Net Item
9105194	Inspection– Requested No Hard Tri-fold Tonneau Cover/No Cover Package Installed	0.2	ZFAT	N/A
9105195	Install Pickup Box Cover Clamp Kit	0.9	ZFAT	N/A
	ADD: Adjust Latches	0.2		
	ADD: Install Additional Components from Recall N192217500 Kit	0.8		
9105196	Customer Reimbursement Approved - For USA and Canada dealers only	- N/A	ZFAT	*
9105197	Customer Reimbursement Denied – For USA dealers only	N/A	ZFAT	**

Note: To avoid having to “H” route the customer reimbursement transaction for wholesale approval, it must be submitted prior to the repair transaction.

* For USA and Canada: Submit the dollar amount reimbursed to the customer in Net/Reimbursement. Submit \$20.00 administrative allowance in Net/Admin Allowance.

Customer Satisfaction Program

N192285071 Tonneau Cover Retention



** Submit \$10.00 administrative allowance in Net/Admin Allowance.

Preliminary Inspection

NOTE: For customers who signed a Notice to Customer disclosure form upon taking vehicle delivery and the customer no longer wishes to have the hard tri-fold tonneau cover installed, the dealer is to inspect for NO hard tri-fold tonneau cover package. Close out that VIN using labor code 9105194 inspection – No hard tri-fold tonneau cover/No cover package installed. The dealer is to also use labor code 9105196 to reimburse the customer for the hard tri-fold tonneau cover (previously removed before customer took delivery).

If the original hard tri-fold tonneau cover is still in dealer's possession and NEW in the box, then the tonneau should be inspected per the procedure here and repair kit installed if needed, this part can be re-used and sold to a customer. If the tonneau has been installed and removed or has been stored outside of original box, it should be scrapped.

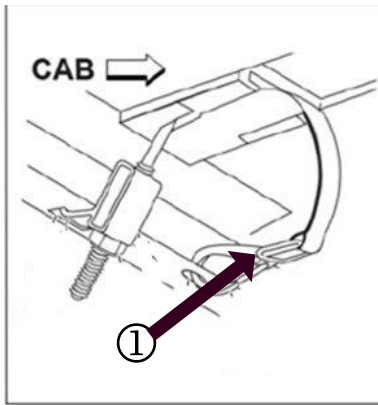

5613815

Open the front section of the tonneau cover and locate the outboard ends of the front hinge track. If the cover already has tethers (1) installed, it is up to date and no further action is required.

Service Procedure

Caution: Use the correct fastener in the correct location. Replacement fasteners must be the correct part number for that application. Fasteners requiring replacement or fasteners requiring the use of thread locking compound or sealant are identified in the service procedure. Do not use paints, lubricants, or corrosion inhibitors on fasteners or fastener joint surfaces unless specified. These coatings affect fastener torque and joint clamping force and may damage the fastener. Use the correct tightening sequence and specifications when installing fasteners in order to avoid damage to parts and systems.

1. Inspect the vehicle and determine if any bedside rails are installed.
2. If any bedside rails are installed, remove and discard the bedside rails.
3. Inspect the bedside upper trim for any dirt or debris, clean as required.
4. Place the cover assembly on a clean non-marring work surface with the front hinge track facing up.

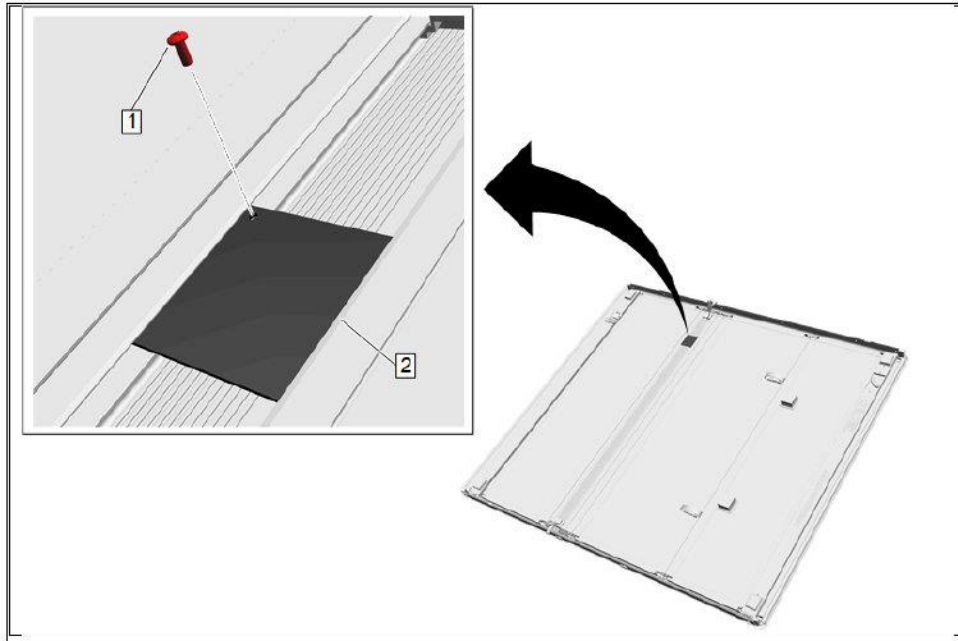

5609953

5. Remove the screw (1) from the hinge plate cover (2), retain the screw.

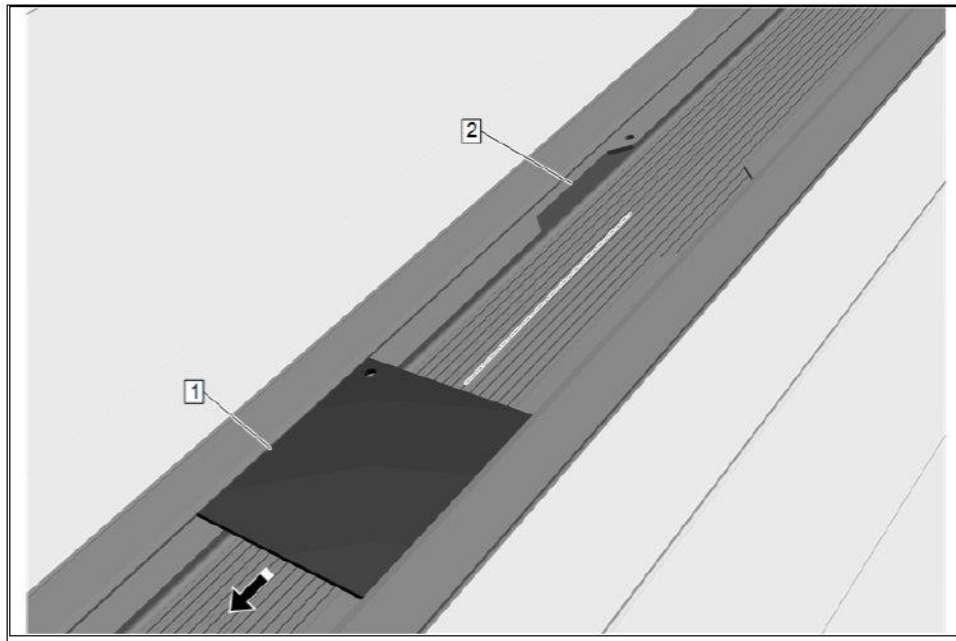

5609957

6. Slide the hinge plate cover (1) toward the center of the panel to expose the hinge cutout opening (2).

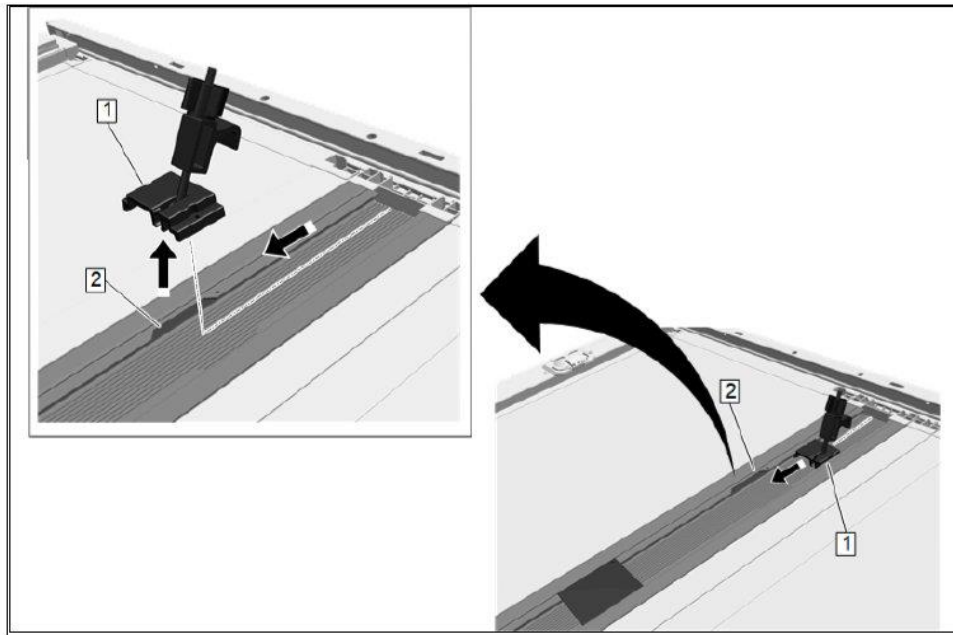

5609962

7. Slide the existing clamp bolt assembly (1) out of the cutout (2). Discard the clamp bolt assembly, it will not be reused.
8. Repeat step 7 for opposite side.

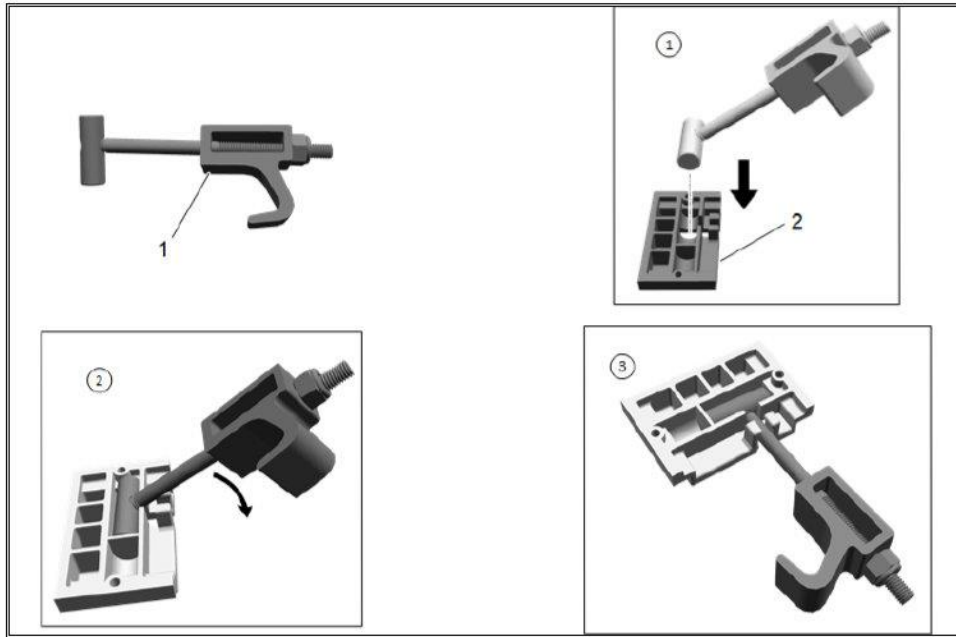

5609963

Note: Follow sequence (1-3) in graphic as shown.

9. Locate the new clamp bolt assembly (1) and new slide plate (2). Snap barrel of clamp bolt into slide plate.

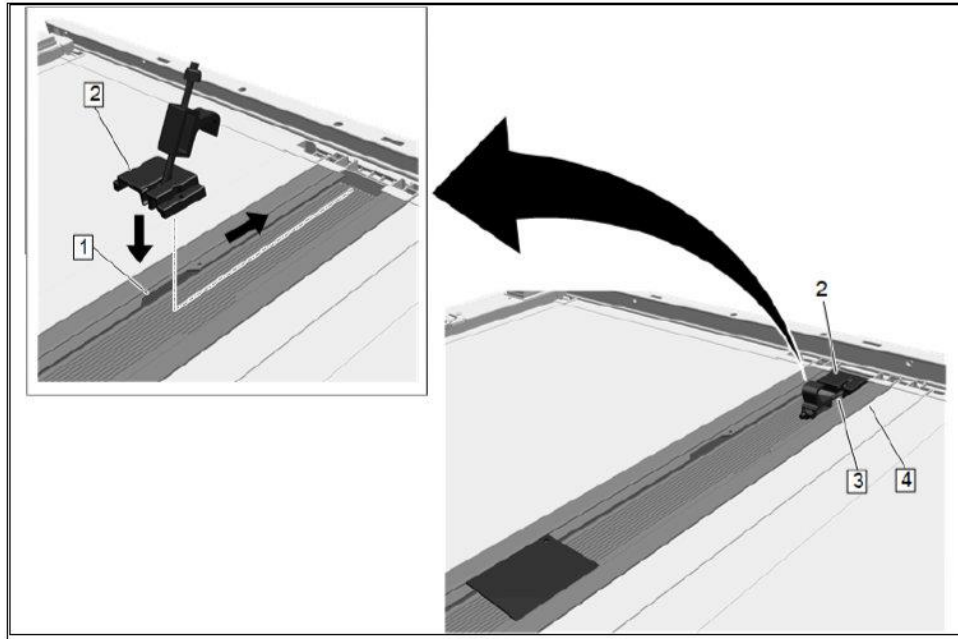

5609964

10. Install the new clamp bolt assembly (2) through the cutout (1) and slide outboard.
11. Push the clamp bolt down into the hinge plate.
12. Verify the clamp bolt stud (3) is offset toward the folded edge of the hinge plate (4).
13. Repeat steps 9-12 for the opposite side.

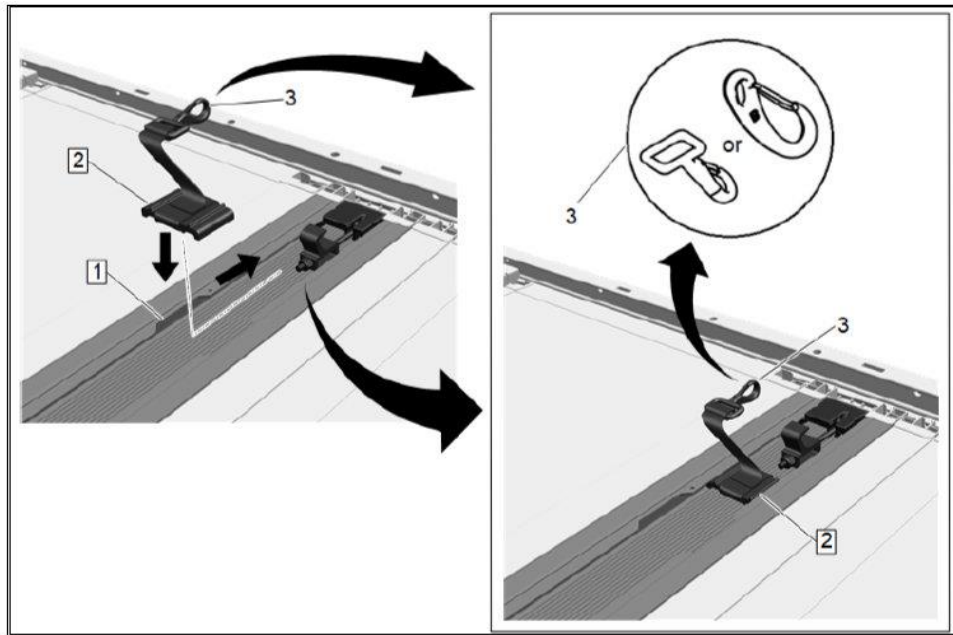

5609965

Note: Hook style may vary.

14. Hold the tether assembly (2) over the hinge plate cutout (1) and verify the hook (3) is positioned outboard of the mounting plate and the hook clasp is facing away from the channel.
15. Install the tether plate portion of the tether assembly (2) into the cutout (1) of the hinge plate. Slide the tether assembly to the outboard side.
16. Repeat steps 14-15 for the opposite side.

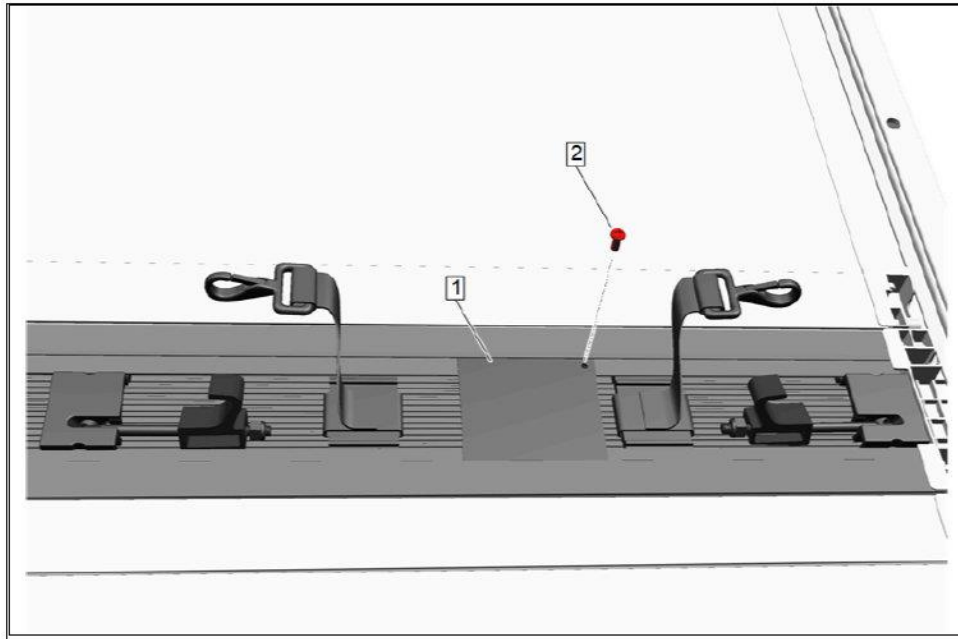

5609967

17. Position the hinge plate cover (1) in the track over the cutout.
18. Reinstall screw (2) previously removed from step 5.
19. Tape new owner's manual to the B surface of the tonneau cover.
20. Remove side rails from the pickup box by removing the T30 torx screws.

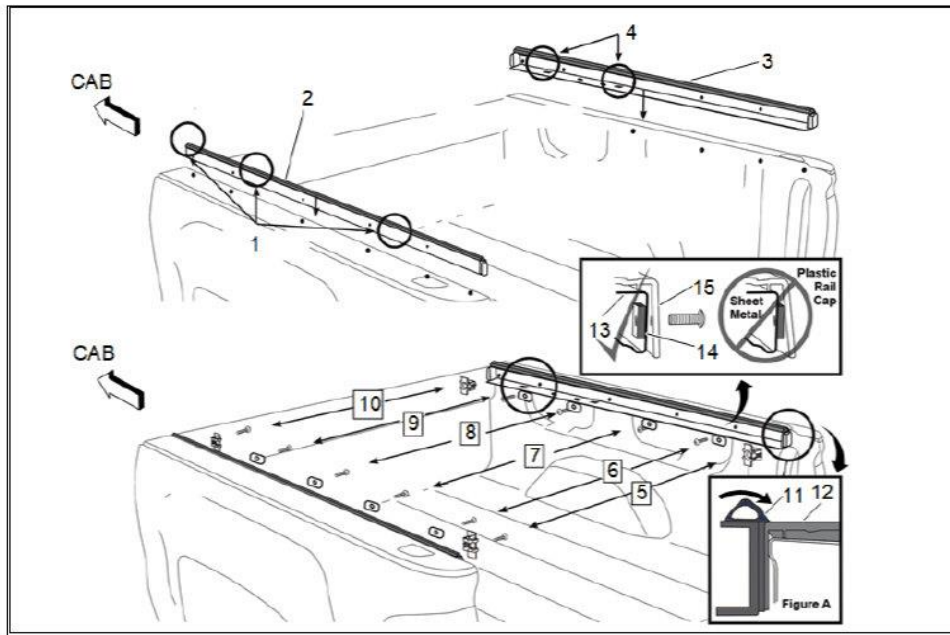

5609968

Note: If vehicle is equipped with power end gate refer to **For Power Open and Close End Gate Only** section at the end of these instructions.

Note: Driver side rail (1) has three notches, passenger side rail (3) has two notches (4).

Note: Backing plates (14) are installed on the back side of the sheet metal (13). **DO NOT** install backing plates between plastic trim caps (15) and sheet metal.

21. Install driver side rail (1) in the order shown using Loctite 272 on screws prior to installing. Hand tighten attachment bolt (5) and (10) in box nuts. Hand tighten (6), (7), (8) and (9) into backing plates. Align the edge of the rail seal (11) with the top of the plastic trim cap (12) as shown in figure A. Use T30 torx to fully tighten the bolts (6), (7), (8) and (9) followed by bolts (5) and (10) to 8.7 N.m (6.4 lb ft). Repeat for passenger side rail (3).
22. Position tonneau cover onto the front on the pickup box.

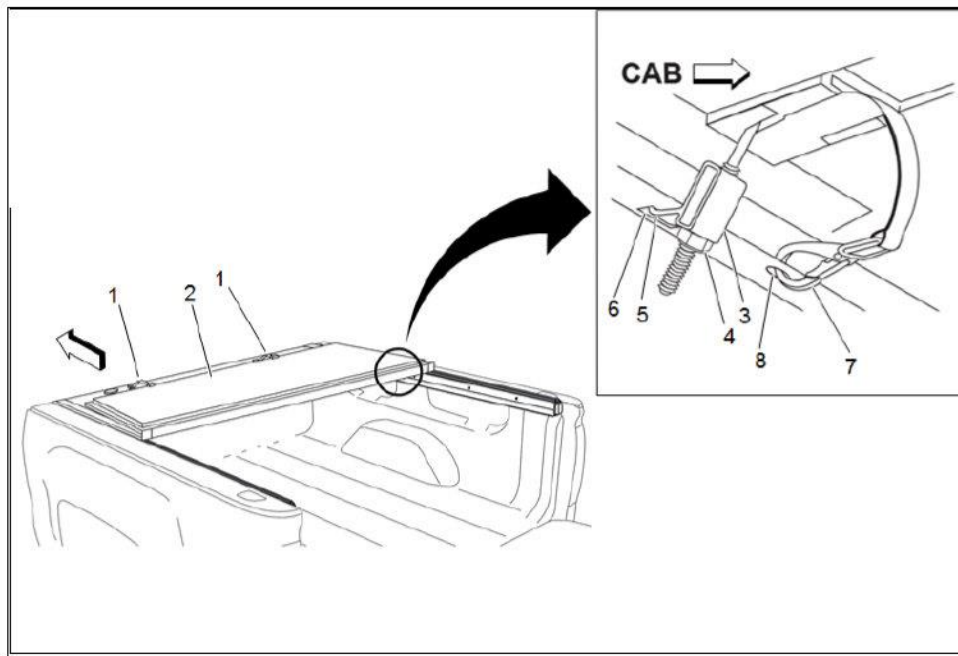

5609969

23. Locate the rectangular notch (6) in the driver and passenger side rails that align with the clamps. Align the stationary clamps (3) to the rectangular notch (6). Position the cover (2) evenly side to side and rest the cab seal smoothly along the cab wall of the bed. Position the stationary clamps (3) so that the hook (5) rests inside the rectangular notch (6) in the rail. Tighten the nut (4). Be sure to tighten each side evenly. Tighten only until tonneau cannot shift from its position. **DO NOT OVER TIGHTEN.** Over tightening of nut (4) can cause failure to clamping system. Be sure to clip safety tether (7) to hole (8) in rail from top down for ease of removal.

Note: The end gate must be open when closing tonneau cover (2).

24. Unclip the tie down straps (1) and unfold the tonneau (2).



Adjustment Instructions for Vehicles That Have Had Recall N192217500 performed.



5368725

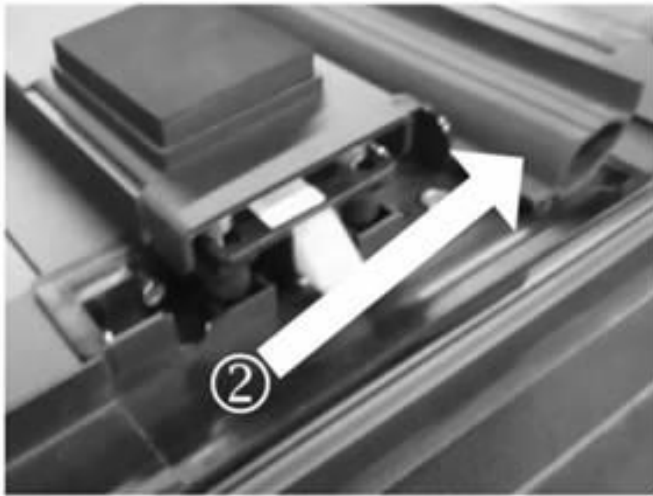

5368719

Important: Verify the front tonneau cover seal is the revised “fin” style seal (1). If the “bulb” style seal is installed (2), replace the seal. Refer to steps 1-5 of the Adjustment Instructions for Vehicles That Have NOT Had Recall N192217500 performed below.

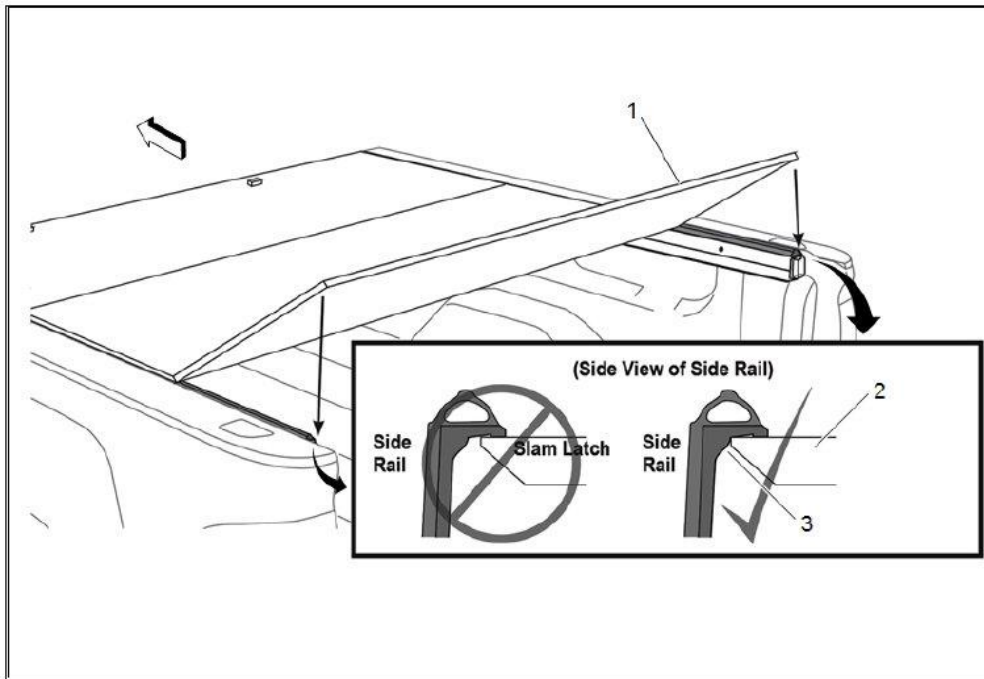

5609971

1. With both hands, press down on the rear bar (1) until the rear slam latches (2) engage driver side and passenger side rails (3).
2. Lift the forward panel to 30°. Drop the forward panel to engage the driver side and passenger side slam latches (2).

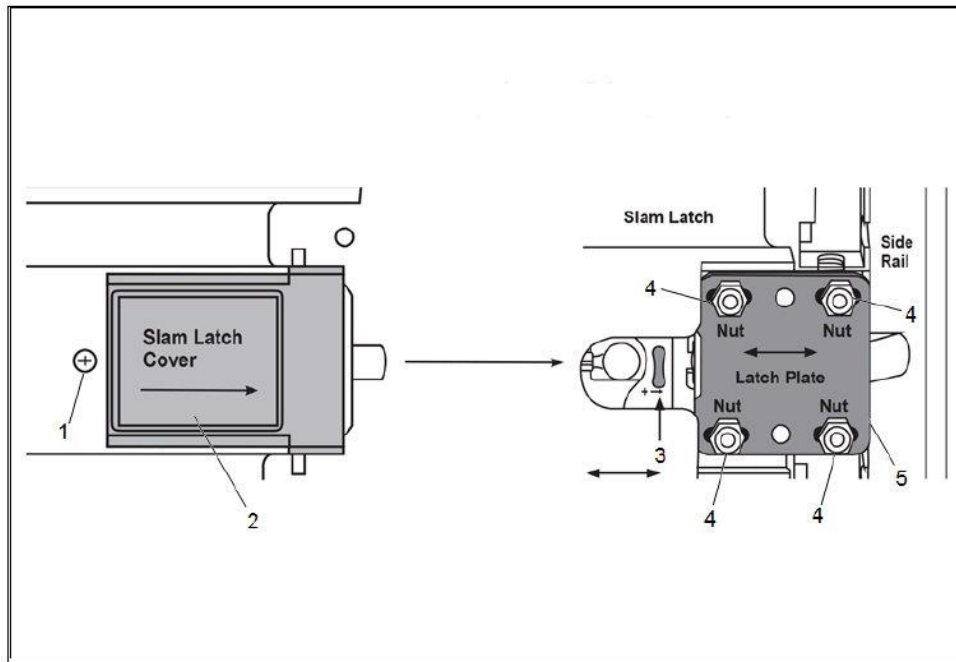

5609975

3. If the slam latches do not engage or there is excessive slack in the latches, adjust latches in or out and up or down. To adjust, remove the screw (1) from the slam latch cover (2) and side cover off. Loosen the four nuts (4) to move the latches in or out, move the metal latch plate. To move the latches up or down, move the plastic adjuster tab (3). Tighten the four nuts. Repeat steps 1 and 2.

Customer Satisfaction Program N192285071 Tonneau Cover Retention



For Power Open and Close End Gate Only

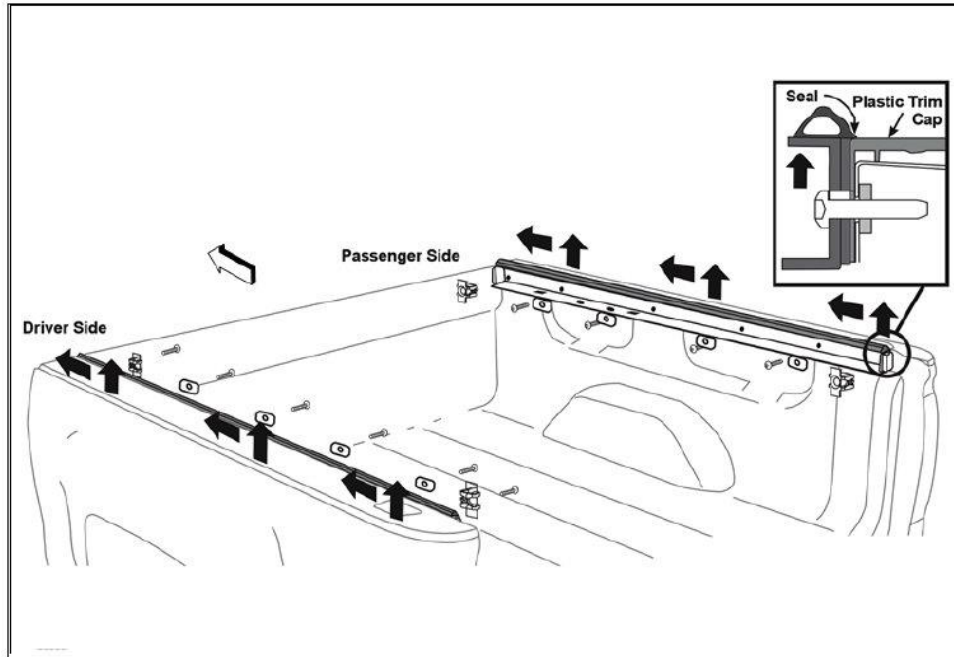

5609977

Note: Tonneau cover side rails must be adjusted to full up position and cover assembly must be adjusted to full forward position to ensure proper powered end gate closure to fully latched position.

During Step 21: While tightening each bolt to attach the rails, pull up and forward on the rails. Refer to Step 21 for bolt tightening sequence. Cycle the power end gate no less than 5 times to assure proper function.

Adjustment Instructions for Vehicles That Have NOT Had Recall N192217500 performed.



5331766

1. Open the front panel (closest to the cab) of the tonneau cover and lay it flat.

Customer Satisfaction Program

N192285071 Tonneau Cover Retention

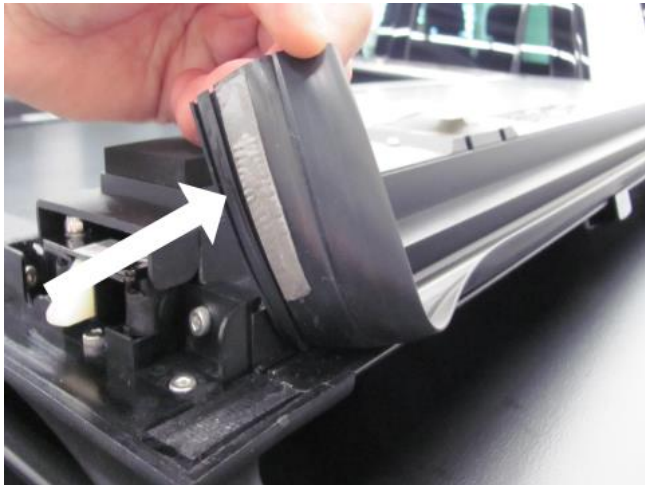

5331768

2. Locate the outboard ends of the front seal. Peel the seal loose at both ends. With the adhesive ends released, slide the front seal out of the channel. Discard the seal.

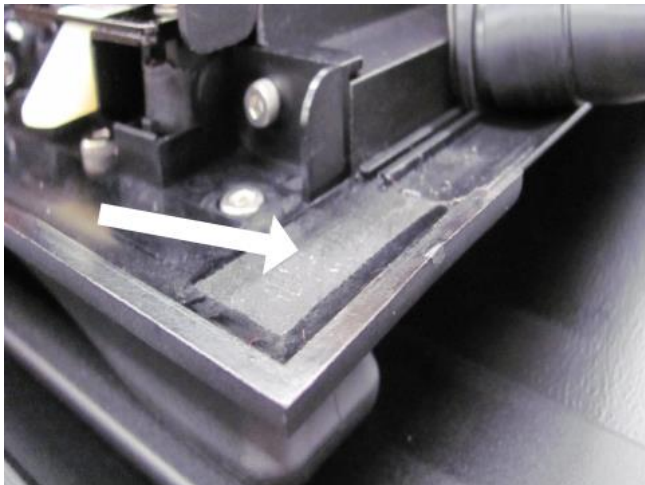

5331770

3. Remove any residual double-sided tape and adhesive from the end caps using a general-purpose adhesive remover.

Note: Apply a light coating of glass cleaner to the first 60cm. (2 ft.) of the seal. This will act as a lubricant allowing the seal to easily slide into the channel.

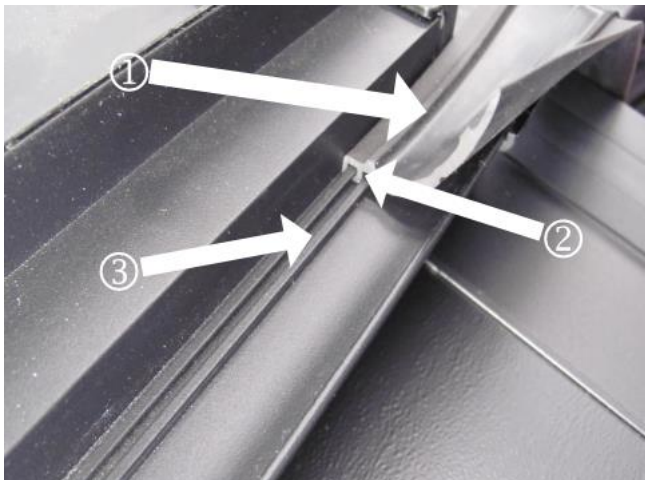

5331771

4. Install the new front lip seal (1), ensure the seal anchor (2) mates with the extrusion channel (3). Slide the seal across the full length of the channel, **ensure seal is centered** on the front panel.



5. Locate the double-sided tape at both outer ends of the new seal. Remove the protective film and press the seal (2) firmly onto the corner cap (1), apply pressure for 15 seconds to allow the adhesive to bond. Perform this step on both ends of the new seal.

Note: Perform the following steps on both the left and right front latch assemblies.

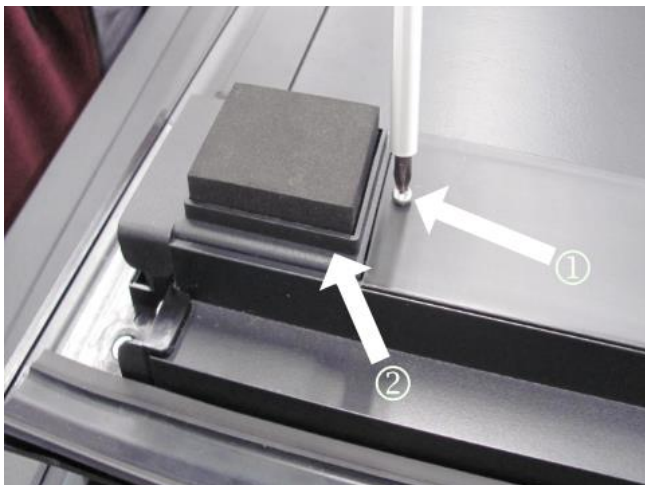

6. Locate the latches on the open front panel. Remove the screw (1) and slide the plastic closeout cover out (2).

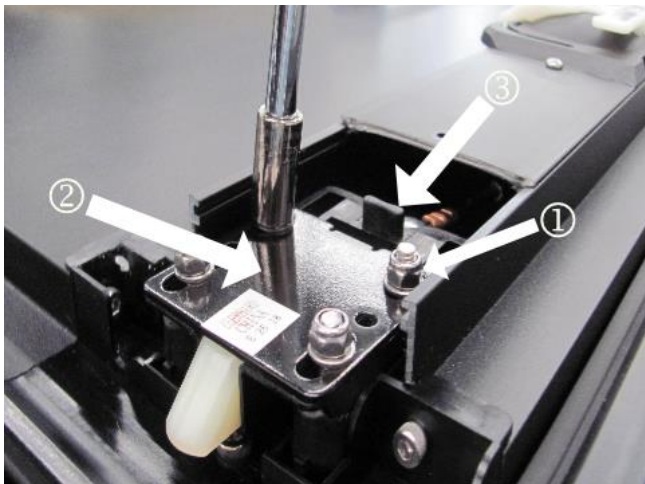

7. Remove the 4 nuts and 4 washers (1). Discard the nuts, retain the washers. Remove the latch plate (2) and U-shaped adjustment step (3) and set them to the side, a cable will remain attached to the latch.

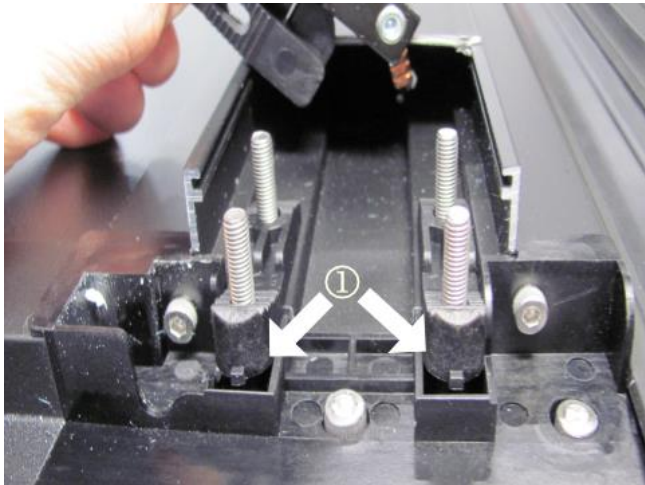

5331777

8. Remove the two existing lower adjusters and discard (1). Install the two new adjusters provided in the attachment kit.

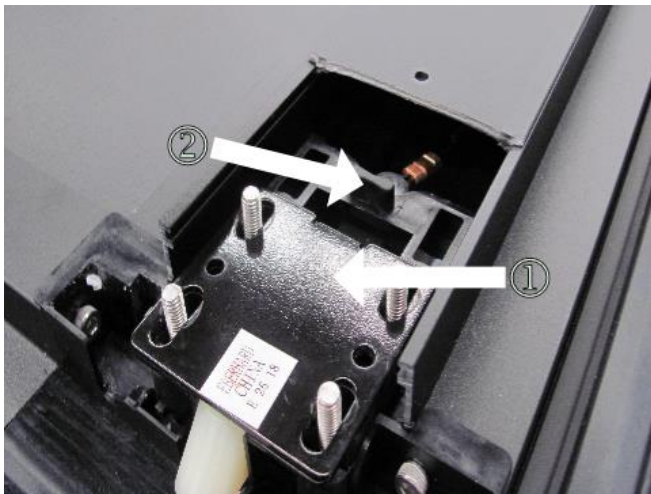

5331778

9. Reinstall the original U-shaped adjuster (2) and latch (1).

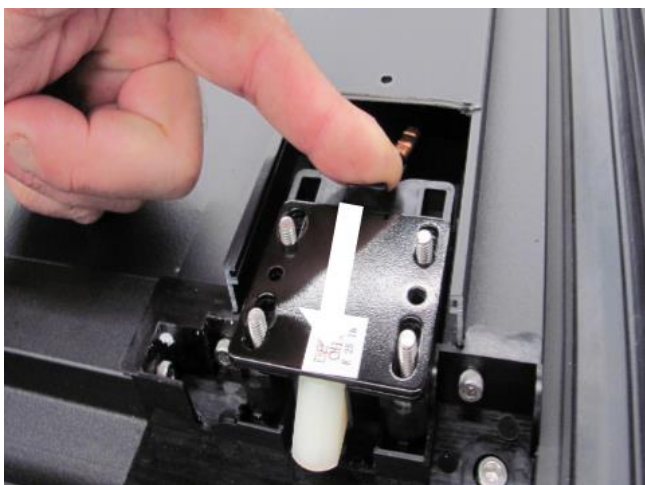

5331779

10. Set the latch to the correct (maximum) height, push on the inboard standing tab and slide the U-shaped adjuster to the full outboard position.

Important: Do not overtighten the fasteners or damage may occur to the top cover.

Customer Satisfaction Program N192285071 Tonneau Cover Retention

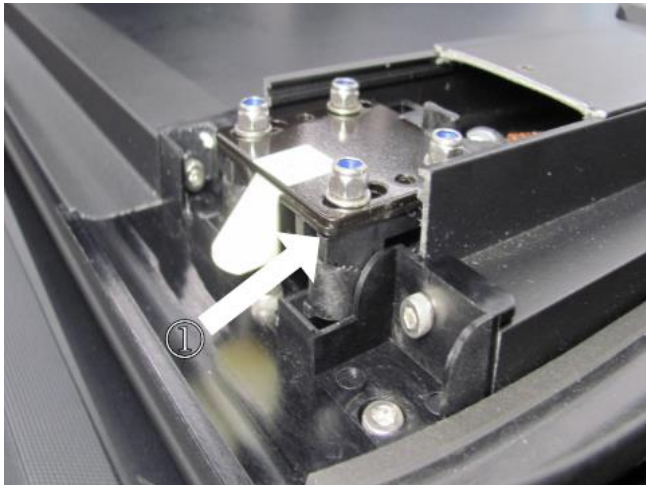

5331782

11. Loosely install the 4 original washers and the 4 new nuts supplied with the attachment kit. Align the outer edge of the latch with the edge of the plastic corner rib (1). Tighten the 4 nuts to 1Nm (9 lb.-in).

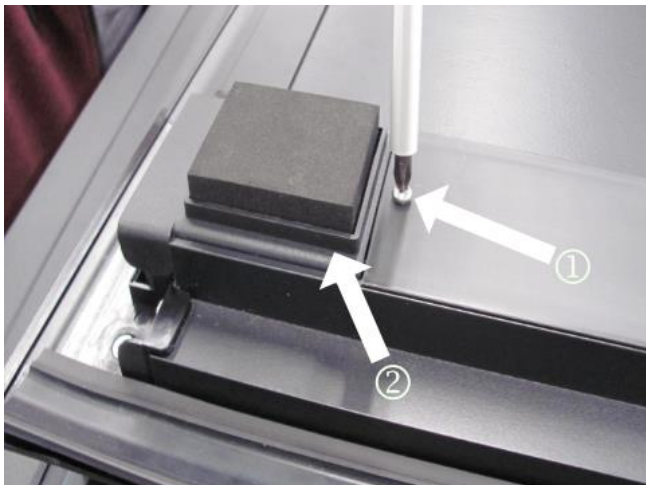

5331774

12. Slide the latch close out cover (2) into position and install the fastener (1).
13. Lift the forward panel to 30°. Drop the forward panel to engage the driver side and passenger side slam latches. Ensure the latch fully engages under the pickup box rail on both sides. Adjust as required.
14. Open the rear panel and locate the left (driver side) latch. Perform steps 6-12 at this location.
Important: *The right-side rear latch requires specific fitting steps to prevent interference. The following steps are specific to the right rear latch.*
15. With the rear panel open, locate the right (passenger side) latch. Perform steps 6-12 at this location, **with one** exception.

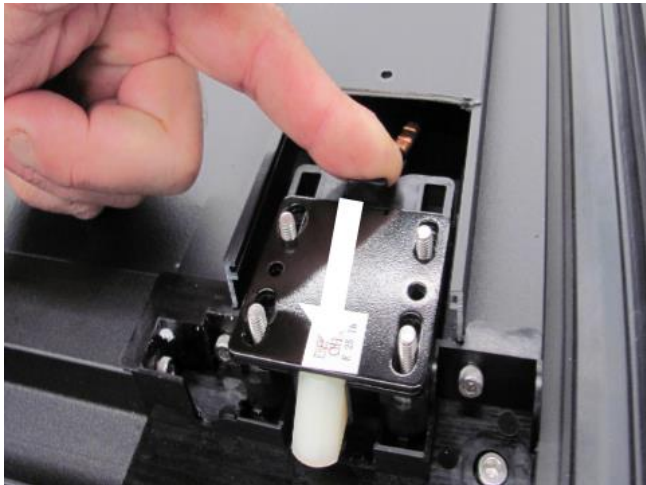

5331779

- When reinstalling the U-shaped adjuster and latch, push on the inboard standing tab and slide the U-shaped adjuster to the full outboard position.



5331784

- While applying light finger pressure to the metal plate, push the adjuster inboard two steps. You should be able to feel the two steps as well as hear a “click” type sound.
- With pressure still applied to the metal plate, install the 4 existing washers along with the 4 new nuts supplied with the attachment kit. Tighten the 4 nuts to 1Nm (9 lb.-in).

Customer Satisfaction Program

N192285071 Tonneau Cover Retention

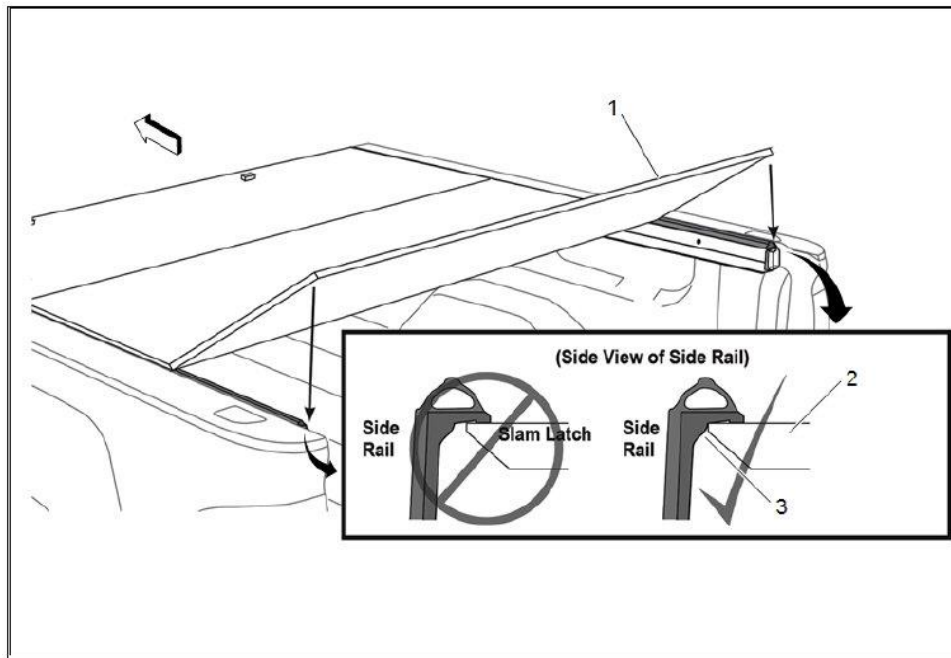

5609971

16. With both hands, press down on the rear bar (1) until the rear slam latches (2) engage driver side and passenger side rails (3). Adjust if required.

Dealer Responsibility

All new, used, GM Certified Used, courtesy transportation vehicles, dealer shuttle vehicles, etc. in dealers' possession and subject to this program must be held and inspected/repaired per the service procedure of this bulletin before customers take possession of these vehicles. Involved vehicles must be held and not delivered to customers, dealer-traded, released to auction, used for demonstration, or any other purpose.

All GM Certified Used vehicles currently in the dealers' inventory within the Certified Pre-Owned Inventory System (CPOIS) will be de-certified and must be held and remedied per the service procedure in this bulletin. Upon submitting an accepted/paid warranty transaction in the Global Warranty Management (GWM) system, the vehicle can be re-certified for sale within the CPOIS system, or once again be used in the CTP program.

Dealers are to service all vehicles subject to this program at no charge to customers, regardless of mileage, age of vehicle, or ownership, through July 31, 2022. Customers who have recently purchased vehicles sold from your vehicle inventory, and for which there is no customer information indicated on the involved vehicle listing, are to be contacted by the dealer. Arrangements are to be made to make the required correction according to the instructions contained in this bulletin. A copy of the customer letter is provided in this bulletin for your use in contacting customers. Program follow-up cards should not be used for this purpose, since the customer may not as yet have received the notification letter.

In summary, through July 31, 2022, whenever a vehicle subject to this field action enters your vehicle inventory you must take the steps necessary to ensure the program correction has been made before selling the vehicle. In addition, for vehicles entering your facility for service, you are required to ensure the customer is aware of the open field action and make every reasonable effort to implement the program correction as set forth in this bulletin prior to releasing the vehicle.

Dealer Reports

For dealers with involved vehicles, a listing with involved vehicles has been prepared and will be provided to U.S. and Canadian dealers through the GM GlobalConnect Recall Reports or sent directly to export dealers. The listing may contain customer names and addresses obtained from Motor Vehicle Registration Records. The use of such motor vehicle registration data for any purpose other than follow-up necessary to complete this program is a violation of law in

Customer Satisfaction Program

N192285071 Tonneau Cover Retention



several states/provinces/countries. Accordingly, you are urged to limit the use of this report to the follow-up necessary to complete this program.

Courtesy Transportation – For USA & Canada

Courtesy transportation is available for customers whose vehicles are involved in a product program and still within the warranty coverage period. See General Motors Service Policies and Procedures Manual for courtesy transportation program details.

Customer Notification

USA & Canada - General Motors will notify customers of this program on their vehicle (see copy of customer letter included with this bulletin).

Customer Reimbursement

Customer requests for reimbursement of previously paid repairs to correct the condition described in this bulletin are to be submitted to the dealer prior to or by July 31, 2021. See General Motors Service Policies and Procedures Manual, Product Field Action Customer Reimbursement Procedure (USA & Canada) or local Policies and Procedures, for details.

GM bulletins are intended for use by professional technicians, NOT a "do-it-yourselfer". They are written to inform these technicians of conditions that may occur on some vehicles, or to provide information that could assist in the proper service of a vehicle. Properly trained technicians have the tools, equipment, safety instructions, and know-how to do a job properly and safely. If a condition is described, **DO NOT** assume that the bulletin applies to your vehicle, or that your vehicle will have that condition. See your dealer for information on whether your vehicle may benefit from the information.



**We Support
Voluntary Technician
Certification**

Customer Satisfaction Program

N192285071 Tonneau Cover Retention



July 2020

This notice applies to your vehicle, **VIN:** _____

Dear General Motors Customer:

As you are aware, as part of equipment recall N192285070, the tri-fold tonneau cover that was originally equipped on your vehicle was removed prior to delivery. This letter is to inform you that you can now make a service appointment to have the improved tonneau cover system installed on your vehicle.

Your satisfaction with your Chevrolet Silverado or GMC Sierra 1500 series truck is very important to us, so we are announcing a program to correct this issue.

What We Will Do: Your GM dealer will replace the tonneau rails and clamps and add a tether to prevent the tonneau from detaching onto the roadway even if improperly installed. If the vehicle was covered by equipment recall 19E031 (N192217500), the dealer will also confirm that the repair for equipment recall 19E031 (N192217500) was correctly performed. This service will be performed for you at **no charge until July 31, 2022**. After that, any applicable warranty will apply.

What You Should Do: To limit any possible inconvenience, we recommend that you contact your dealer as soon as possible to schedule an appointment for this repair. By scheduling an appointment, your dealer can ensure that the necessary parts will be available on your scheduled appointment date.

Reimbursement: Even though you may have previously had repairs for this condition, you will still need to take your vehicle to your dealer for additional repairs. If you have already paid for repairs for the condition described in this letter, please complete the enclosed reimbursement form and present it to your dealer with all required documents. Working with your dealer will expedite your request, however, if this is not convenient, you may mail the completed reimbursement form and all required documents to Reimbursement Department, PO Box 33170, Detroit, MI 48232-5170. The completed form and required documents must be presented to your dealer or received by the Reimbursement Department by July 31, 2021, unless state law specifies a longer reimbursement period.

If you have any questions or concerns that your dealer is unable to resolve, please contact the appropriate Customer Assistance Center at the number listed below.

Division	Number	Text Telephones (TTY)
Chevrolet	1-800-222-1020	1-800-833-2438
GMC	1-800-462-8782	1-800-462-8583
Puerto Rico – English	1-800-496-9994	
Puerto Rico – Español	1-800-496-9993	
Virgin Islands	1-800-496-9994	

We truly appreciate you taking the time to remedy your vehicle as we know your time is valuable. We want you to know that we will do our best, throughout your ownership experience, to ensure that your GM vehicle provides you many miles of enjoyable driving.

Neelie O'Connor
Global Executive Director
Customer Experience Operations

Enclosure
N192285071