

**Safety Recall: 2013-15 Accord (CVT only) Driveshaft Inspection**

Supersedes 20-125, dated February 2, 2021, to revise the information highlighted in yellow

**AFFECTED VEHICLES**

Year	Model	Trim Level	VIN Range
2013-15	Accord	CVT models only	Check the iN VIN status for eligibility.

**REVISION SUMMARY**

This bulletin has been extensively revised. American Honda recommends reviewing the entire bulletin.

**BACKGROUND**

Due to improper manufacturing, the paint on the driveshaft near the dynamic damper may peel and chip over time, exposing the bare metal and potentially causing it to corrode under the dynamic damper. A corroded driveshaft may break during high torque conditions rendering the vehicle without propulsion, or allowing the vehicle to roll while in Park, which can increase the potential of a crash or injury.

This recall applies only to vehicles with driveshafts that have a dynamic damper. If neither driveshaft has a dynamic damper, this recall does not apply. If one driveshaft has a dynamic damper, do the INSPECTION PROCEDURE on that driveshaft only, and replace both driveshafts if it fails the inspection.

The affected VIN population for this recall was determined based on information available to Honda at the time the recall was announced. If a customer believes their vehicle should be included in the campaign due to information not available to Honda (either at the time of recall announcement or thereafter), contact your DPSM and have the customer contact American Honda with their concern. For any questions or concerns that customers may have, you may direct them to contact American Honda's Customer Support & Campaign Center at **888-234-2138**.

**CUSTOMER NOTIFICATION**

Owners of affected vehicles will be sent a notification of this campaign.

Do an iN VIN status inquiry to make sure the vehicle is shown as eligible.

Some vehicles affected by this campaign may be in your new or used vehicle inventory.

Failure to repair a vehicle subject to a recall or campaign may subject your dealership to claims or lawsuits from the customer or anyone else harmed as a result of such failure. Before selling a vehicle in inventory, always check if it is affected by a safety recall by conducting a VIN status inquiry.

**CUSTOMER INFORMATION:** The information in this bulletin is intended for use only by skilled technicians who have the proper tools, equipment, and training to correctly and safely maintain your vehicle. These procedures should not be attempted by "do-it-yourselfers," and you should not assume this bulletin applies to your vehicle, or that your vehicle has the condition described. To determine whether this information applies, contact an authorized Honda automobile dealer.

## CORRECTIVE ACTION

Inspect both driveshafts for signs of corrosion or paint defects near the dynamic damper. Replace both driveshafts if there is corrosion or the paint is peeling, cracking, or blistering near the dynamic damper of either driveshaft.

### NOTE:

- If either driveshaft fails inspection and parts are not available, the vehicle must not be returned to the customer until replacement driveshafts are installed. If the customer needs alternative transportation due to parts shortages, contact your DPSM and make arrangements for the customer.
- Failure to follow the inspection and repair procedure correctly may result in the driveshaft breaking under the dynamic damper. This could render the vehicle without propulsion, or allowing the vehicle to roll while in Park. Improper repairs could be subject to debit.
- This recall applies only to vehicles with driveshafts that have a dynamic damper. If neither driveshaft has a dynamic damper, this recall does not apply. If one driveshaft has a dynamic damper, do the INSPECTION PROCEDURE on that driveshaft only, and replace both driveshafts if it fails the inspection.

## PARTS INFORMATION

Part Name	Part Number	Quantity
Driveshaft Assembly Kit (includes 2 axle assemblies)	06440-T2A-305	1
Hardware Kit* (includes axle nuts, castle nuts, and set rings)	06440-T2A-306	1
Sealing Washer* (10 mm)	90471-PW7-A00	1

\*required for each Driveshaft Assembly Kit.

## REQUIRED MATERIALS

Part Name	Part Number	Quantity
HCF-2 CVT Fluid (1 bottle will repair 5 vehicles)	08200-HCF2	1
M-77 Assembly Paste (1 tube will repair 12 vehicles)	08798-9010	1

## TOOL INFORMATION

Tool Name	Part Number	Quantity
Ball Joint Remover, 32 mm	07MAC-SL00102	1
Ball Joint Thread Protector, 14 mm	071AF-SZNA100	1

## WARRANTY CLAIM INFORMATION

Operation Number	Description	Flat Rate Time	Defect Code	Symptom Code	Template ID	Failed Part Number
2195B3	Inspect both driveshaft assemblies only.	0.3 hr	6DZ00	W9F00	A20125A	44305-T2A-000
2191CB	Replace both driveshaft assemblies. Includes driveshaft inspection, CVT fluid check, wheel alignment, and road test.	1.5 hr	6DZ00	W9F00	A20125B	44305-T2A-000

Skill Level: Repair Technician

## INSPECTION PROCEDURE

**NOTE:** This recall applies only to vehicles with driveshafts that have a dynamic damper. If neither driveshaft has a dynamic damper, this recall does not apply. If one driveshaft has a dynamic damper, do the INSPECTION PROCEDURE on that driveshaft only, and replace both driveshafts if it fails the inspection.

1. Raise and support the vehicle.
2. Use a clean shop towel to wipe any excess dirt and debris from the driveshafts between the outer joint and the dynamic damper.

**NOTE:** Paint chips may be sharp and could cut bare hands. Use gloves when wiping the driveshaft.

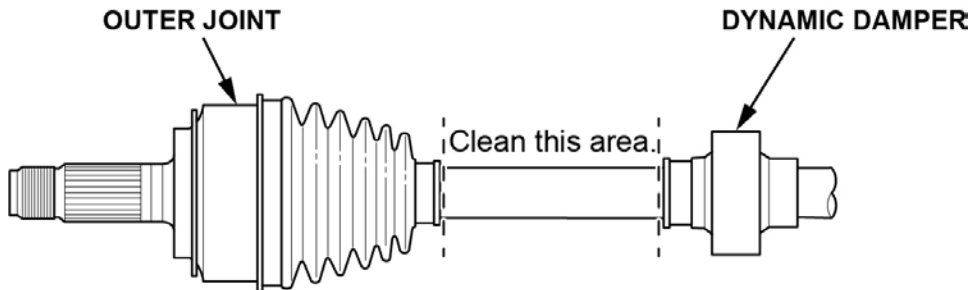

3. Using a ruler and yellow paint marker, measure **40 mm (1-11/16 in)** away from the dynamic damper, and mark the driveshaft with a dot. Click [HERE](#) to view the video on how to do the inspection procedure.

**NOTE:** Do not scribe or damage the painted surface of the driveshaft. Any replaced driveshafts may be called in for inspection.

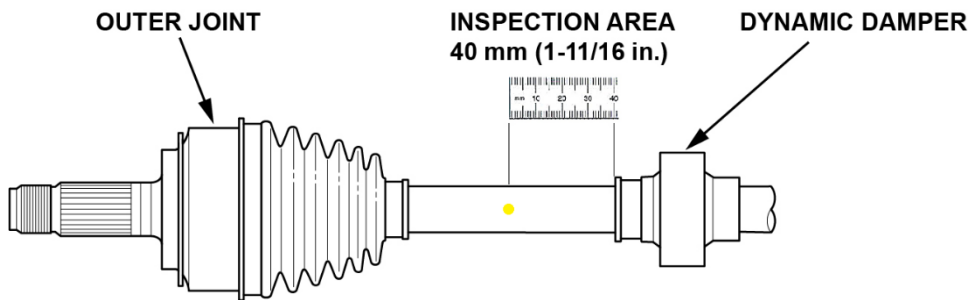

4. Rotate the axle 1/4 turn and repeat the above step **3 times** until there are 4 paint dots on the axle.

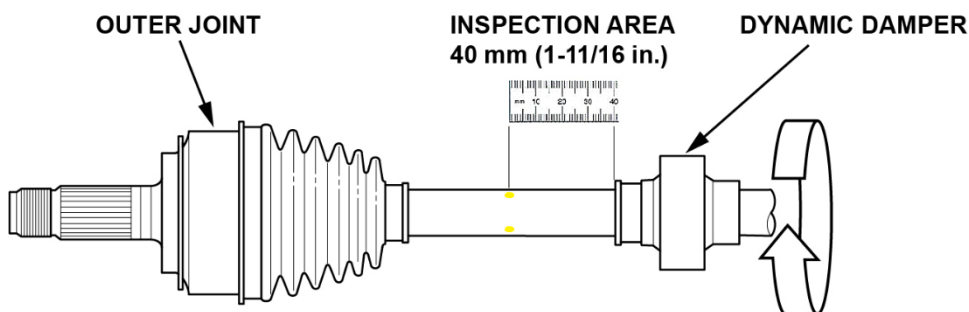

5. Connect the 4 painted dots around the axle using masking tape.

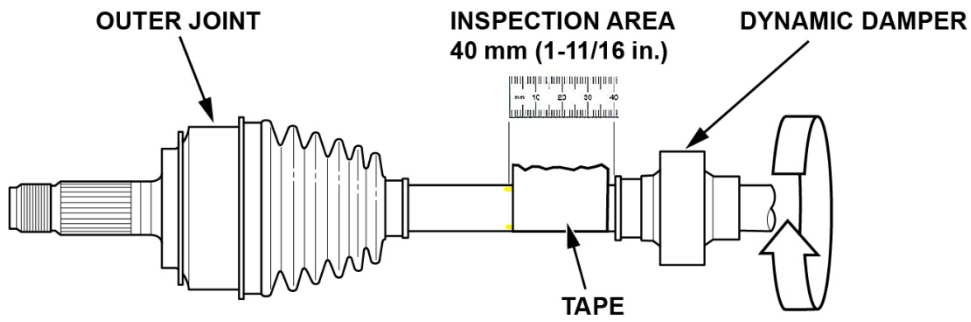

6. Using the masking tape as a guide, trace a line all around the axle using the yellow paint marker.

NOTE: Marking the line accurately is important, especially if there is damage close to or inside the 40 mm line.

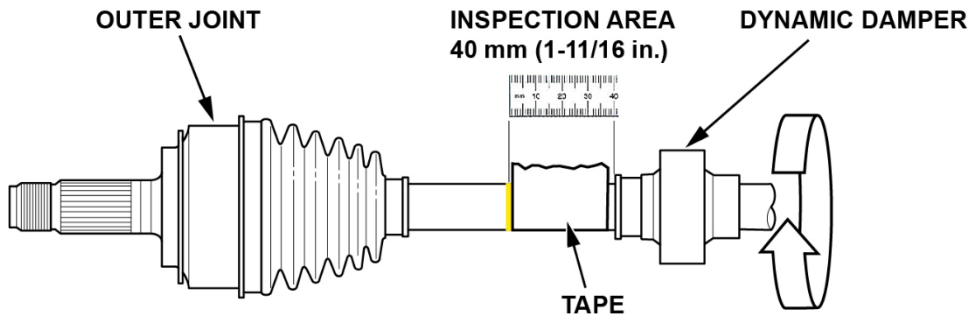

7. Remove the masking tape.

8. Inspect the driveshaft surface between the dynamic damper and the line for peeling paint, cracks, or blisters.

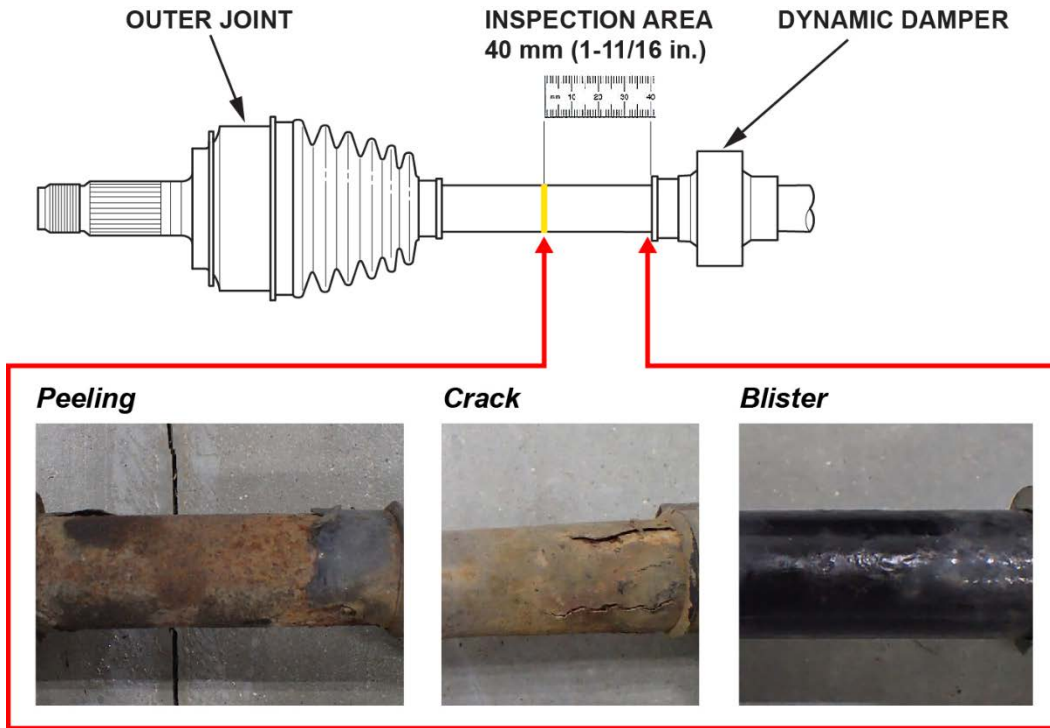

NOTE: Corrosion or paint defects between the outer joint and the yellow line are OK.

Is there peeling paint, cracks, or blisters on either driveshaft within **40 mm (1-11/16 in)** of the dynamic damper?

- Yes. Go to the REPAIR PROCEDURE.
- No. The driveshafts are OK. Return the vehicle to the customer.

## REPAIR PROCEDURE

1. Remove both front wheels.

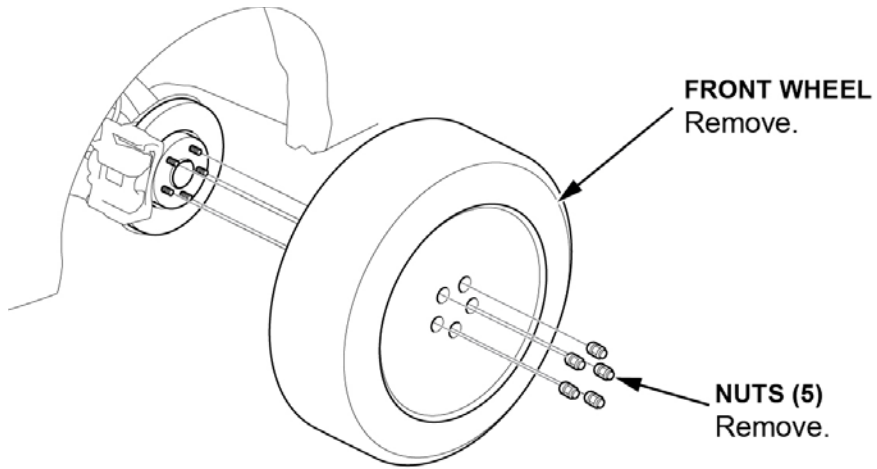

2. Pry up the stake on both spindle nuts and remove them.

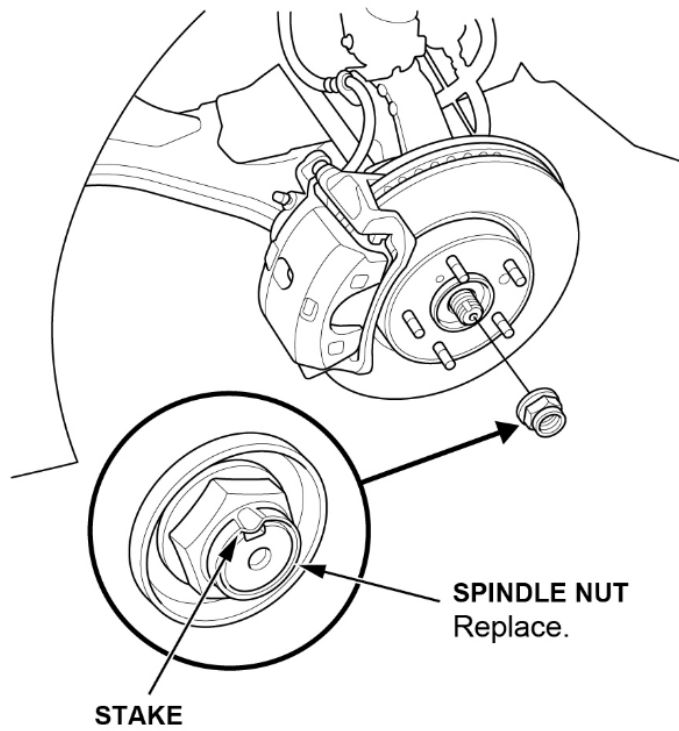

3. Disconnect both lower ball joints.

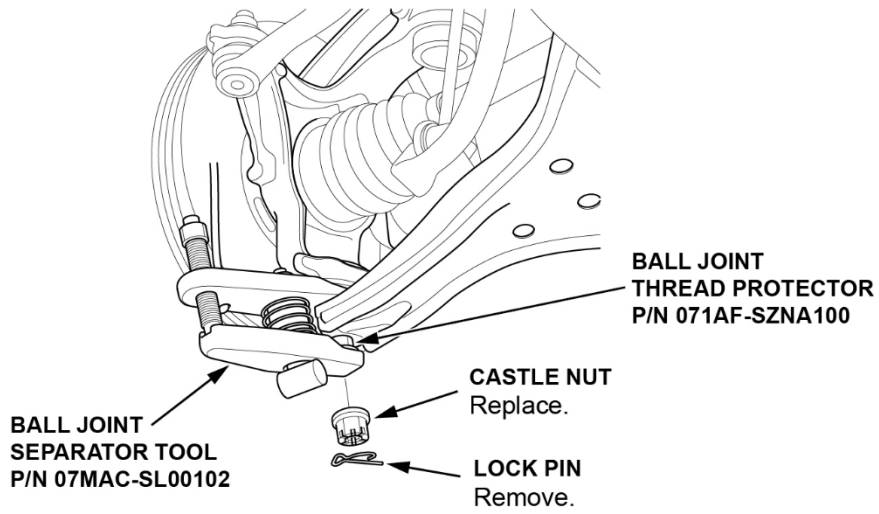

4. Use a soft-face hammer to separate the outboard joints from the steering knuckles.

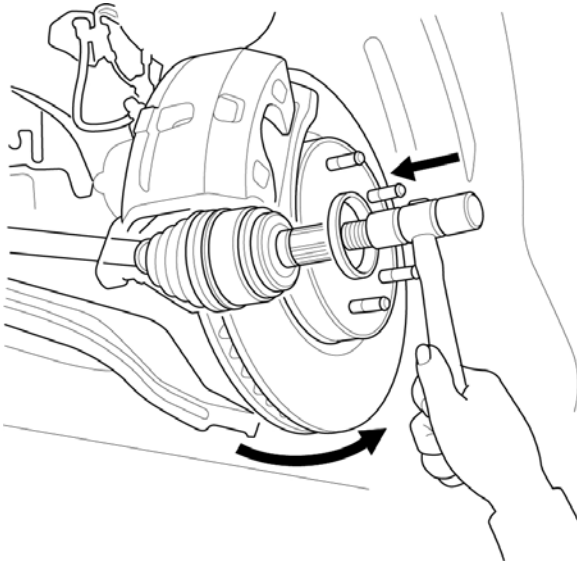

5. Use a pry bar to pry the inboard joint of the left driveshaft from the transmission.

NOTE: Be careful not to damage the transmission oil seal with the pry bar.

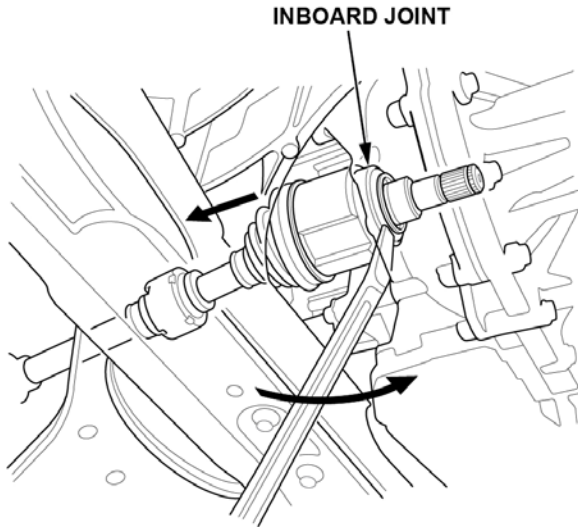

6. Remove the left driveshaft as an assembly.

NOTE: Pull the driveshaft straight out to avoid damaging the transmission oil seal.

7. Use a drift punch and a hammer to remove the right driveshaft from the intermediate shaft.

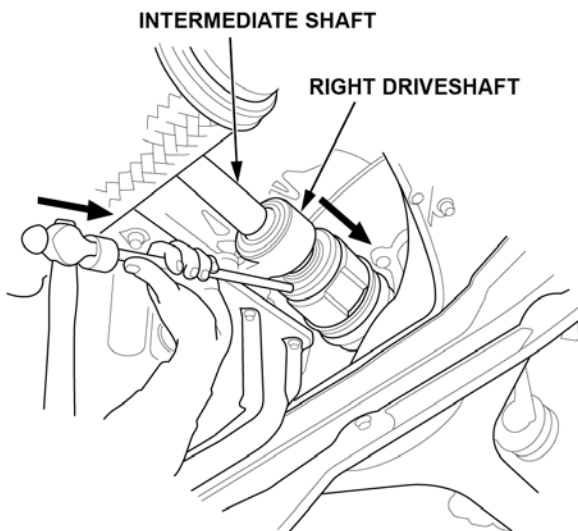

8. Remove the right driveshaft as an assembly.



9. Replace the set ring on the intermediate shaft with the one provided in the hardware kit.

**Right Driveshaft**

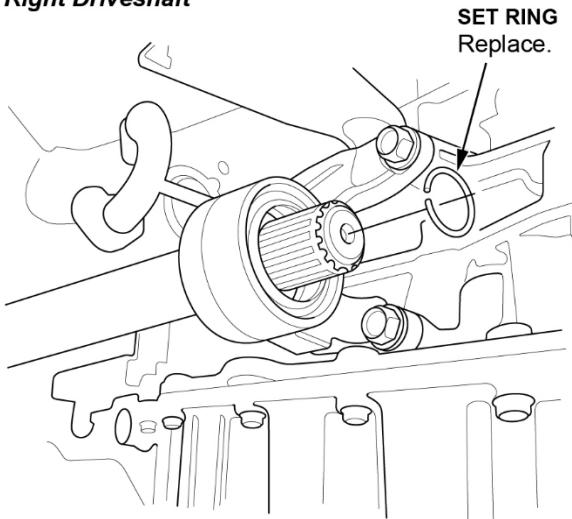

10. **Make sure the mating surfaces are clean**, then install the new driveshafts. Insert them until the set rings lock in the grooves.

NOTE: Insert the left driveshaft straight in to avoid damaging the transmission oil seal.

**Left Driveshaft**

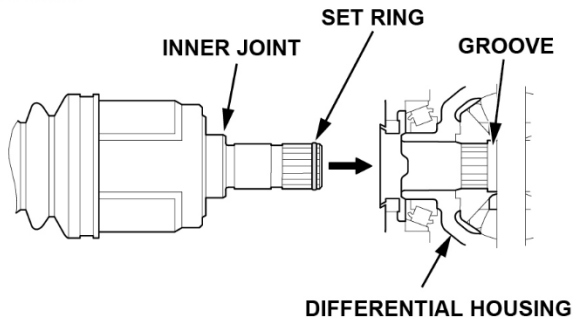

**Right Driveshaft**

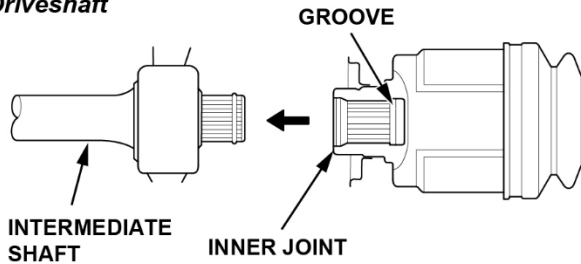

11. **Make sure the bearing and spindle are clean of any debris or rust particles using a shop towel and/or compressed air.** Then, apply about **3 g (0.11 oz)** of M-77 Assembly Paste (P/N 08798-9010) to the contact area of the outboard joint and the front wheel bearings.

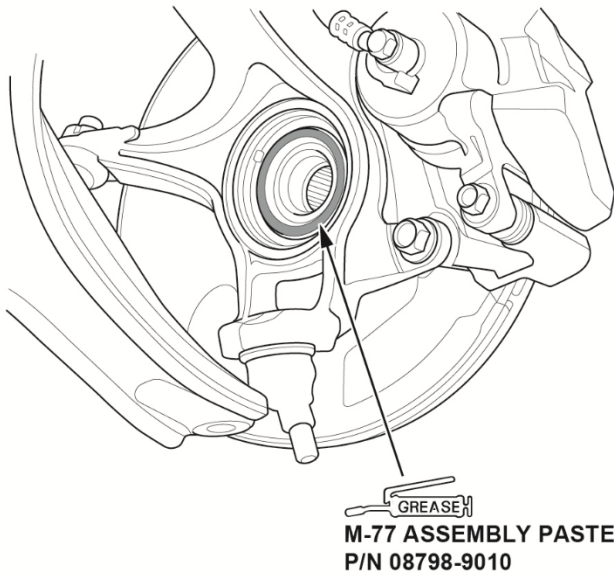

12. Pull the steering knuckles outwards and insert the outer driveshaft joints into the hub.
13. Connect the lower ball joints to the lower control arm. Use new castle nuts provided in the hardware kit.

NOTE: Torque the castle nuts to the lower torque specification, then tighten them only far enough to align the slot with the ball joint pin hole. Do not align the castle nuts by loosening them. When aligned, install the lock pin through the hole.

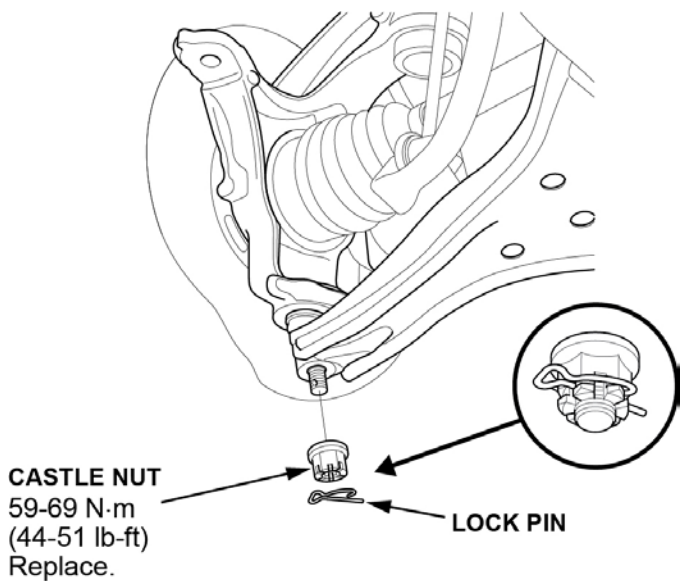

14. Install the new spindle nut provided in the hardware kit, and torque it to **328 N·m (242 lb-ft)** using a torque wrench. If you are going to use an air or battery powered impact gun to install the nut, make sure to turn down the air or power so you do not overtighten it, then torque it to specification using a torque wrench.

NOTE: Apply oil or lube to the spindle nut surface only. Do not apply any to the threads of the spindle or nut.

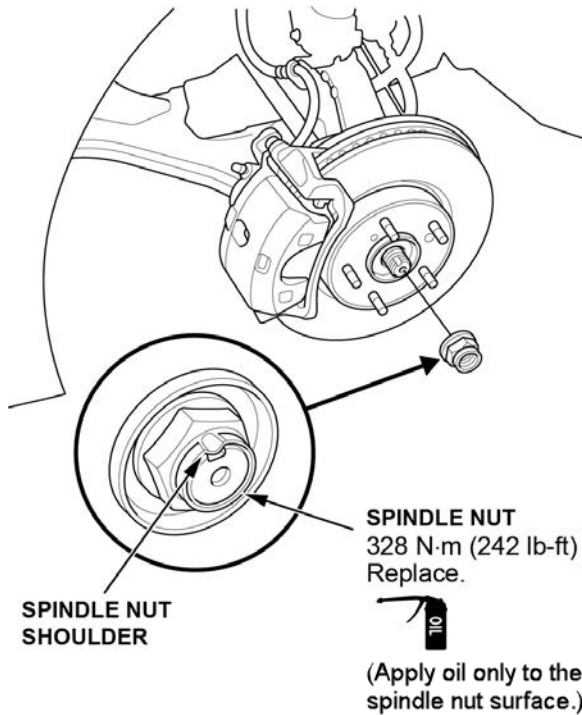

15. Use a drift punch to stake the spindle nut shoulder against the notch on each driveshaft.
16. Install both front wheels.

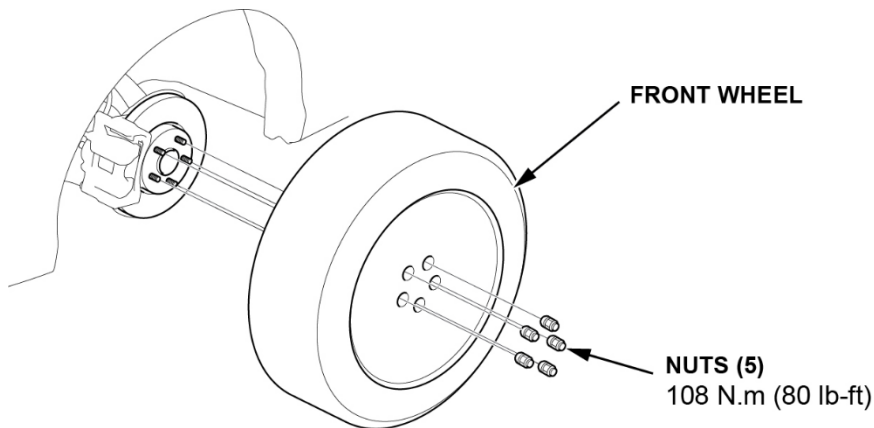

17. Start the engine.
18. While pressing the brake pedal, shift the transmission to P>R>N>D>S>D>N>R>P (with paddle shifters) or P>R>N>D>S>L>S>D>N>R>P (without paddle shifters) for about **3 seconds** in each position.
19. Turn the engine OFF.

20. Remove the check bolt and sealing washer.

NOTE:

- When checking the transmission fluid level at the check bolt, it is not uncommon to find the fluid at the upper or lower level.
- Do the transmission fluid level check immediately after the shift lever operation.
- The check bolt and the transmission fluid may be hot.

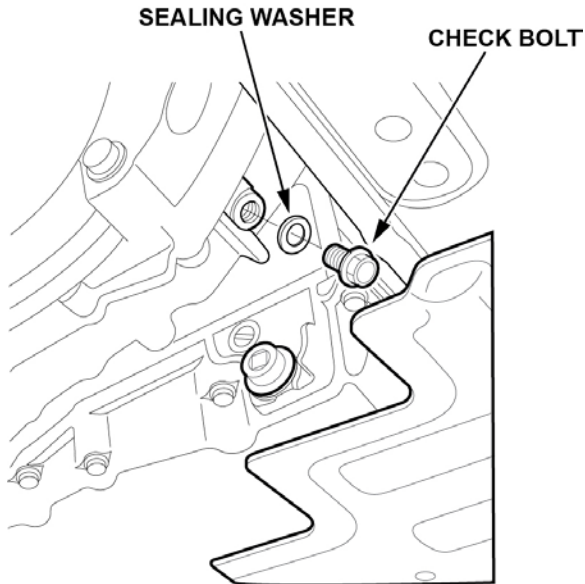

The transmission is at the proper level if the fluid is dripping from the hole gradually.

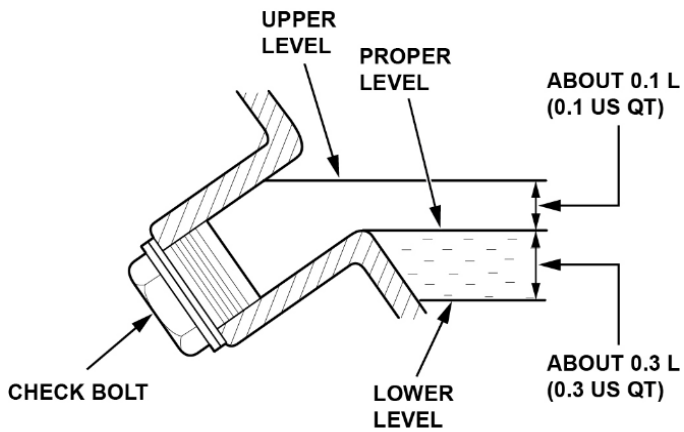

- *If the transmission fluid is flowing out of the check hole, wait for until it is dripping from the hole gradually. Then, go to step 24.*
- *If the transmission fluid is dripleess from the check hole, loosely install the check bolt and go to the next step.*

21. Remove the filler cap.

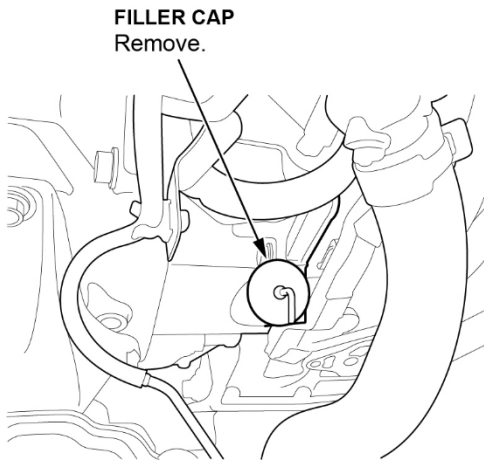

22. Fill the transmission with a suitable amount of HCF-2 CVT Fluid.

**NOTE:** Using the wrong type of fluid will damage the transmission.

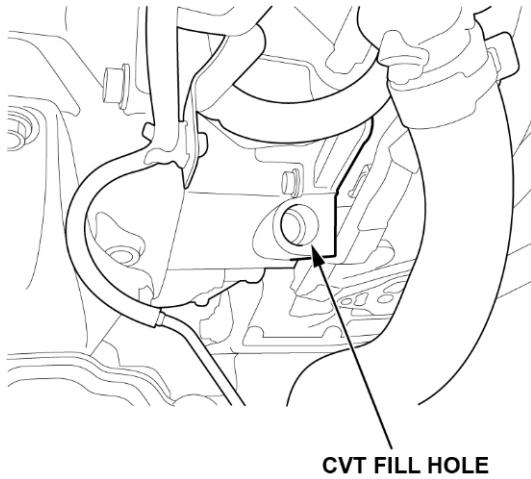

23. Install the filler cap in the direction shown and restart the procedure at step 17.

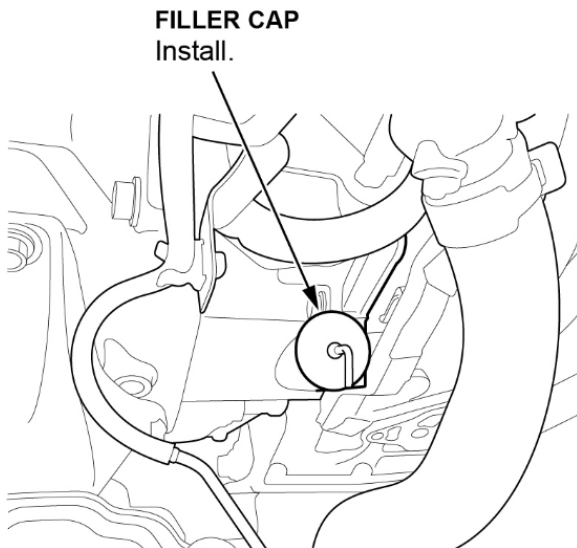

24. Install the original check bolt with a new sealing washer.

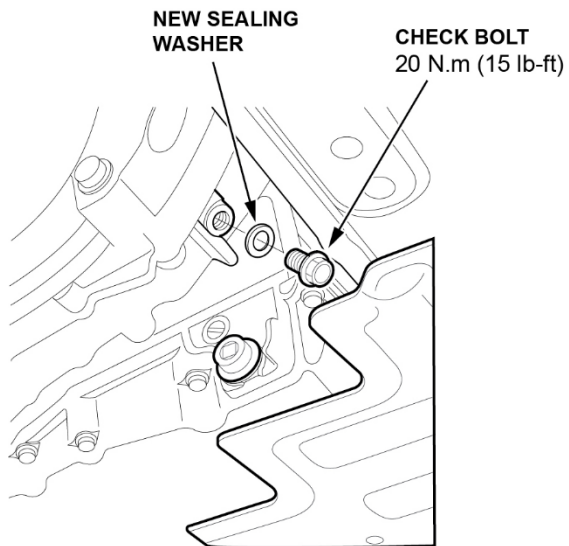

25. Check the wheel alignment and adjust as necessary.

26. Road test the vehicle.

END