

Classification:

PD20-003

Reference:

ITB20-028

COPYRIGHT© NISSAN NORTH AMERICA, INC.

Date:

December 7, 2020

VOLUNTARY SAFETY RECALL CAMPAIGN REAR PROPELLER SHAFT REPLACEMENT

CAMPAIGN ID #: R20B8
APPLIED VEHICLES: 2011-2013 M56 (Y51)
2012-2013 M35 Hybrid (HY51)
2014 Q70 (Y51)
2014 Q70 Hybrid (HY51)

APPLIED ENGINE: VK56 and VQ35

APPLIED DRIVETRAIN: RWD only

**Check Service COMM or Dealer Business Systems (DBS)
National Service History to confirm campaign eligibility.**

INTRODUCTION

Infiniti is conducting this voluntary safety recall campaign, on certain specific model year 2011-2013 M56, 2012-2013 M35 Hybrid, and 2014 Q70 and Q70 Hybrid vehicles, to replace the rear propeller shaft. This service will be performed at no charge to the customer for parts or labor.

IDENTIFICATION NUMBER

Infiniti has assigned identification number R20B8 to this campaign. This number must appear on all communication and documentation of any nature dealing with this campaign.

RETAILER RESPONSIBILITY

It is the retailer's responsibility to check Service COMM or Dealer Business Systems (DBS) National Service History for the campaign status on each vehicle falling within the range of this voluntary safety recall which for any reason enters the service department. This includes vehicles purchased from private parties or presented by transient (tourist) owners and vehicles in a retailer's inventory. **Federal law requires that new vehicles in retailer inventory which are the subject of a safety recall must be corrected prior to sale. Failure to do so can result in civil penalties by the National Highway Traffic Safety Administration.** While federal law applies only to new vehicles, Infiniti strongly encourages retailers to correct any used vehicles in their inventory before they are retailed.

Infiniti Bulletins are intended for use by qualified technicians, not 'do-it-yourselfers'. Qualified technicians are properly trained individuals who have the equipment, tools, safety instruction, and know-how to do a job properly and safely. **NOTE:** If you believe that a described condition may apply to a particular vehicle, DO NOT assume that it does. See your Infiniti retailer to determine if this applies to your vehicle.

SERVICE PROCEDURE

1. Replace the rear propeller shaft.

- For propeller shaft replacement, refer to the Electronic Service Manual (ESM) section: **TRANSMISSION DRIVELINE > DRIVELINE > REAR PROPELLER SHAFT 3S80A-R > REMOVAL AND INSTALLATION > REAR PROPELLER SHAFT > REMOVAL AND INSTALLATION.**

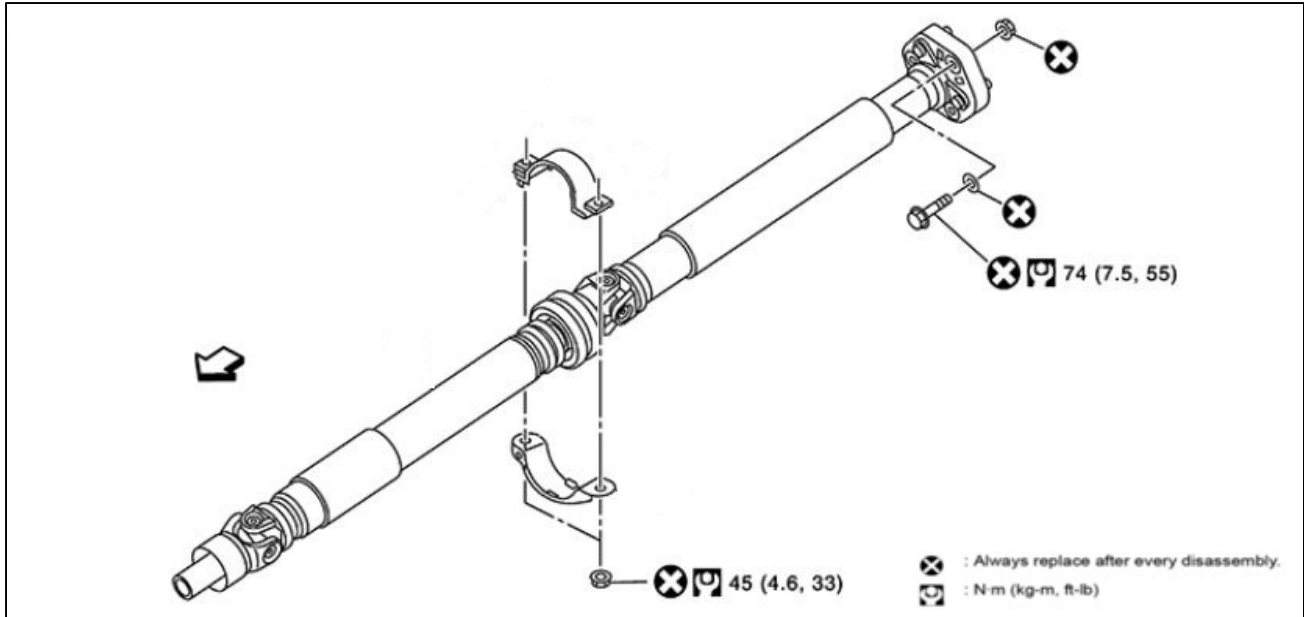

Figure 1

PARTS INFORMATION

MODEL		DESCRIPTION	PART NUMBER	QUANTITY
ALL		NUT (1)	01225-00062	2
		NUT-FIX, PROPELLER SHAFT (1)	37171-AL60A	4
		WASHER-LOCK (1)	37121-JK20B	4
		BOLT-FIX, PROPELLER SHAFT (1)	37120-AH00A	4
VQ35	M35H	PROPELLER SHAFT	C7000-1MG0B	1
	Q70 Hybrid	PROPELLER SHAFT	C7000-3WG0B	1
VK56	M56	PROPELLER SHAFT	C7000-1MC1B	1
	Q70			

(1) Single-use part

CLAIMS INFORMATION

Submit a "CM" line claim using the following claims coding:

CAMPAIGN ("CM") ID	DESCRIPTION	OP CODE	FRT
R20B8	Replace Rear Propeller Shaft	R20B80	1.0 hr

AMENDMENT HISTORY

PUBLISHED DATE	REFERENCE	DESCRIPTION
December 7, 2020	ITB20-028	Original bulletin published

