



Safety Recall

Code: 40Q6

REVISION

Subject Steering Knuckle(s) – STOP DRIVE

Release Date December 16, 2020

REVISION SUMMARY Claiming and work instructions updated for introduction of additional steering knuckle assembly part numbers

Affected Vehicles

Country	Beginning Model Year	Ending Model Year	Vehicle	Vehicle Count
USA	2021	2021	ATLAS	439
USA	2020	2021	ATLAS CROSS SPORT	337
CAN	2021	2021	ATLAS	29
CAN	2020	2021	ATLAS CROSS SPORT	48

Check Campaigns/Actions screen in ELSA on the day of repair to verify that a VIN qualifies for repair under this action. ELSA is the only valid campaign inquiry & verification source.

- ✓ Campaign status must show "open."
- ✓ If ELSA shows other open action(s), inform your customer so that the work can also be completed at the same time the vehicle is in the workshop for this campaign.

Problem Description The steering knuckle(s) in affected vehicles may have been damaged during production. If a damaged steering knuckle is present in the vehicle, the steering may fail without warning, and increasing the risk of a crash. **Due to the safety risk, Volkswagen has issued a STOP DRIVE ADVISORY.**

Corrective Action Inspect and, if necessary, replace the steering knuckle(s).

Code Visibility On or about November 13, 2020, the campaign code was applied to affected vehicles.

Owner Notification Owner notification took place in November 2020 via telephone and mail. Owner letter examples are included in this bulletin for your reference.

Owners are being advised: **DO NOT DRIVE YOUR VEHICLE.** Contact VW Roadside Assistance immediately at 1-800-411-6688 to have your vehicle towed for FREE to your nearest Volkswagen dealer for a FREE inspection & repair. Your Volkswagen dealer will provide you with a loaner vehicle for FREE if needed.

Additional Information Please alert everyone in your dealership about this action, including Sales, Service, Parts and Accounting personnel. Contact Warranty if you have any questions.

IMPORTANT REMINDER ON VEHICLES AFFECTED BY SAFETY & COMPLIANCE RECALL:

New Vehicles in Dealer Inventory: It is a violation of federal law for a dealer to deliver a new motor vehicle or any new or used item of motor vehicle equipment (including a tire) covered by this notification under a sale or lease until the defect or noncompliance is remedied. By law, dealers must correct, prior to delivery for sale or lease, any vehicle

that fails to comply with an applicable Federal Motor Vehicle Safety Standard or that contains a defect relating to motor vehicle safety.

Pre-Owned Vehicles in Dealer Inventory: Dealers should not deliver any pre-owned vehicles in their inventory which are involved in a safety or compliance recall until the defect has been remedied.

Dealers must ensure that every affected inventory vehicle has this campaign completed before delivery to consumers.

Fill out and affix Campaign Completion Label (CAMP 010 000) after work is complete. *Labels can be ordered at no cost via the Compliance Label Ordering portal at www.vwhub.com.*

Parts Information (if necessary)

IMPORTANT PARTS INFORMATION

Due to the limited parts supply at the launch of this campaign, parts must be prioritized for customer owned vehicles. Repairs done to inventory vehicles using parts meant for customer owned cars could be subject to claim cancellation.

Parts Control Type: VIN to Order	If parts are needed to support a vehicle repair: <ul style="list-style-type: none"> • US Dealers - use AVA • CAN Dealers - contact the Parts Specialists via phone (800-767-6552), email (VWoAPartsSpecialists@vw.com), or chat/text with the VIN to order
---	--

Initial Allocation: NO	Due to the small number of affected vehicles there will be no parts allocation. Please reference the Repair Projection Tool (below) to view your potential VIN population.
---	--

Repair Projection Tool: (right click to open)	
--	---

Criteria	Quantity	Part Number	P.O.C. Part Description	Ordering Method	
01	Up to 1	3QF-407-255-E	Housing (steering knuckle - left)	VIN to Order	
		-OR-			
		3QF-498-998*	Steering knuckle assembly – left		
	Up to 1	3QF-407-256-E	Housing (steering knuckle - right)	VIN to Order	
		-OR-			
		3QF-498-998-A*	Steering knuckle assembly - right		
	<p><i>*Note: Assembly part numbers have the wheel bearing and ball joint already installed.</i></p> <ul style="list-style-type: none"> • <i>Bearing (3QF-598-625) would NOT be required.</i> • <i>One Nut (N 909-429-02) would NOT be required</i> • <i>Axle bolt (WHT-005-437-A) IS required</i> 				
	Up to 2	3QF-598-625*	Bearing	VIN to Order	
	Up to 2	N -101-064-02	Nut	VIN to Order	
	Up to 2	N -102-058-02	Nut	VIN to Order	
	Up to 4	N -909-429-02*	Nut	VIN to Order	
	Up to 2	N -909-548-02	Bolt	VIN to Order	
	Up to 6	N -912-332-01	Hex Nut	VIN to Order	
Up to 2	WHT-005-437-A*	12POINT S (axle bolt) <i>Use ONLY if installing a steering knuckle assembly (3QF-498-998 or 3QF-498-998-A)</i>	VIN to Order		

NOTE

The specified part numbers reflect the status at the start of this action. Interim updates made in ETKA can cause a listed part number to become unavailable. In this case, the new part number specified in ETKA should be used.

The repair information in this document is intended for use only by skilled technicians who have the proper tools, equipment and training to correctly and safely maintain your vehicle. These procedures are not intended to be attempted by "do-it-yourselfers," and you should not assume this document applies to your vehicle, or that your vehicle has the condition described. To determine whether this information applies, contact an authorized Volkswagen dealer. ©2020 Volkswagen Group of America, Inc. and Volkswagen Canada. All Rights Reserved.

Claim Entry Instructions

The labor times listed here may differ from the labor operations and labor times listed in ELSA.

After campaign has been completed, enter claim as soon as possible to help prevent work from being duplicated elsewhere. Attach the ELSA screen print showing action open on the day of repair to the repair order.

If customer refused campaign work:

- ✓ U.S. dealers: Submit request via WISE under the *Campaigns/Update/Recall Closure* option.
- ✓ Canada dealers: Upload the repair order [signed by customer] to Volkswagen WIN/Operations/Campaign Closure.

Service Number	40Q6		
Damage Code	0099		
Parts Vendor Code	WWO		
Claim Type	Sold vehicle: 7 10 Unsold vehicle: 7 90		
Causal Indicator	Mark labor as causal		
Vehicle Wash/Loaner	Do not claim wash/loaner under this action U.S.A.: Loaner/rental coverage cannot be claimed under this action. However, loaner/rental may be covered under the Alternate Transportation Program. Please refer to the Volkswagen Warranty Policy and Procedures Manual for loaner claims information and reimbursement details. Canada: Loaner/rental coverage cannot be claimed under this action. Please refer to Volkswagen Service Loaner Program to determine loaner eligibility.		
Criteria I.D.	01		
	Inspect left and right steering knuckles, no further work required		
	LABOR		
	Labor Op	Time Units	Description
	0183 00 99	20	Inspect left and right steering knuckles

Continued on next page

-OR-	Inspect left and right steering knuckles, one steering knuckle requires replacement		
LABOR			
Labor Op	Time Units	Description	
4050 55 99	170	Replace one steering knuckle	
4495 03 99	100	Vehicle alignment front + rear measure	
<i>ADD as needed:</i>			
4488 15 99	20	Front wheel track adjust	
4493 15 99	20	Rear wheel track adjust	
4494 15 99	20	Rear wheel camber adjust	
PARTS			
Quantity	Part Number	Description	
1.00	3QF407255E or 3QF407256E	Housing (steering knuckle)	
<i>-Or-</i>			
1.00	3QF498998 or 3QF498998A	Steering knuckle assembly with bearing	
<i>-And-</i>			
1.00	3QF598625	Bearing <i>(claim ONLY if Housing 3QF407255E or 3QF407256E is installed)</i>	
1.00	N 10106402	Shouldered Hex. Nut, Self-Locking	
1.00	N 10205802	Shouldered Hex. Nut, Self-Locking	
2.00	N 90942902	Hex. Nut, Self-Locking <i>(claim ONLY one if Housing 3QF407255E or 3QF407256E is installed)</i>	
1.00	N 90954802	Oval Hexagon Socket Head Bolt	
3.00	N 91233201	Hex. Nut	
1.00	WHT005437A	12Point S (axle bolt) <i>(claim ONLY if steering knuckle assembly 3QF498998 or 3QF498998A is installed)</i>	

Continued on next page

-OR-	Inspect left and right steering knuckles, both steering knuckles require replacement		
	LABOR		
	Labor Op	Time Units	Description
	4050 56 99	330	Replace left and right steering knuckles
	4495 03 99	100	Vehicle alignment front + rear measure
	<i>ADD as needed:</i>		
	4488 15 99	20	Front wheel track adjust
	4493 15 99	20	Rear wheel track adjust
	4494 15 99	20	Rear wheel camber adjust
	PARTS		
	Quantity	Part Number	Description
	1.00	3QF407255E or 3QF498998	Housing (left) or Steering knuckle assembly with bearing (left)
	1.00	3QF407256E or 3QF498998A	Housing (right) or Steering knuckle assembly with bearing (right)
	<i>-And-</i>		
	Up to 2.00	3QF598625	Bearing <i>(claim ONLY if Housing 3QF407255E or 3QF407256E is installed)</i>
	2.00	N 10106402	Shouldered Hex. Nut, Self-Locking
	2.00	N 10205802	Shouldered Hex. Nut, Self-Locking
	4.00	N 90942902	Hex. Nut, Self-Locking <i>(claim ONLY two if Housing 3QF407255E and 3QF407256E is installed)</i>
	2.00	N 90954802	Oval Hexagon Socket Head Bolt
	6.00	N 91233201	Hex. Nut
	Up to 2.00	WHT005437A	12Point S (axle bolt) <i>(claim ONLY if steering knuckle assembly 3QF498998 or 3QF498998A is installed)</i>

-AND- ONLY IF REAR AXLE TOE REQUIRES ADJUSTMENT	Add as needed depending on vehicle equipment and only if vehicle requires driver assist calibration		
	LABOR		
	Labor Op	Time Units	Description
	9163 15 99	40	Adaptive Cruise Control (ACC) System Adjust
	9638 15 99	50	Camera Driver Assist System Adjust
	0150 00 50	Time stated on diagnostic protocol	GFF operations

The repair information in this document is intended for use only by skilled technicians who have the proper tools, equipment and training to correctly and safely maintain your vehicle. These procedures are not intended to be attempted by "do-it-yourselfers," and you should not assume this document applies to your vehicle, or that your vehicle has the condition described. To determine whether this information applies, contact an authorized Volkswagen dealer. ©2020 Volkswagen Group of America, Inc. and Volkswagen Canada. All Rights Reserved.

Customer Letter Example (USA)

<MONTH YEAR>
<CUSTOMER NAME>
<CUSTOMER ADDRESS>
<CUSTOMER CITY STATE ZIPCODE>

This notice applies to your vehicle: <MODEL YEAR> <BRAND> <CARLINE>, <VIN>

NHTSA: <PENDING>

Subject: URGENT SAFETY RECALL – DO NOT DRIVE YOUR VEHICLE
Safety Recall 40Q6 –Steering Knuckle(s)

Dear Volkswagen Owner,

This notice is sent to you in accordance with the National Traffic and Motor Vehicle Safety Act. Volkswagen has decided that a defect, which relates to motor vehicle safety, exists in certain 2020-2021 model year Volkswagen vehicles. Our records show that you are the owner of a vehicle affected by this action.

What is the issue? The steering knuckle(s) in affected vehicles may have been damaged during production. If a damaged steering knuckle is present in the vehicle, the steering may fail without warning, and increasing the risk of a crash.

Due to the safety risk, Volkswagen has issued a STOP DRIVE advisory. DO NOT DRIVE YOUR VEHICLE.

What will we do? To identify/correct this defect, your authorized Volkswagen dealer will inspect and, if necessary, replace the steering knuckle(s). The inspection will take less than an hour. Replacement, if necessary, may take up to half a day to complete and will be performed for you free of charge. Please keep in mind that your dealer may need additional time for the preparation of the repair, as well as to accommodate their daily workshop schedule.

What should you do? **DO NOT DRIVE YOUR VEHICLE.** Contact VW Roadside Assistance immediately at 1-800-411-6688 to have your vehicle towed for FREE to your nearest Volkswagen dealer for a FREE inspection & repair. Your Volkswagen dealer will provide you with a loaner vehicle for FREE if needed. To set up an appointment online, please visit www.vw.com/find-a-dealer.

Lease vehicles and address changes If you are the lessor and registered owner of the vehicle identified in this action, the law requires you to forward this letter immediately via first-class mail to the lessee within ten (10) days of receipt. If you have changed your address or sold the vehicle, please fill out the enclosed prepaid Owner Reply card and mail it to us so we can update our records.

Can we assist you further? If your authorized Volkswagen dealer fails or is unable to complete this work free of charge within a reasonable time, or if you should have any questions about this communication, please reach out to us using your preferred method of communication at www.vw.com/contact or by calling us at 800-893-5298.

Checking your vehicle for open Recalls and Service Campaigns To check your vehicle's eligibility for repair under this or any other recall/service campaign, please visit www.vw.com/owners/recalls and enter your Vehicle Identification Number (VIN) into the Recall/Service Campaign Lookup tool.

If you still cannot obtain satisfaction, you may file a complaint with: The Administrator, National Highway Traffic Safety Administration, 1200 New Jersey Avenue, SE., Washington, DC 20590; or call the toll-free Vehicle Safety Hotline at 1-888-327-4236 (TTY: 1-800-424-9153); or go to <http://www.safercar.gov>.

We apologize for any inconvenience this matter may cause; however we are taking this action to help ensure your safety and continued satisfaction with your vehicle.

Sincerely,

Volkswagen Customer Protection

The repair information in this document is intended for use only by skilled technicians who have the proper tools, equipment and training to correctly and safely maintain your vehicle. These procedures are not intended to be attempted by "do-it-yourselfers," and you should not assume this document applies to your vehicle, or that your vehicle has the condition described. To determine whether this information applies, contact an authorized Volkswagen dealer. ©2020 Volkswagen Group of America, Inc. and Volkswagen Canada. All Rights Reserved.

Customer Letter Example (Canada)

<MONTH YEAR>

<CUSTOMER NAME>

<CUSTOMER ADDRESS>

<CUSTOMER CITY STATE ZIPCODE>

This notice applies to your vehicle: <MODEL YEAR> <BRAND> <CARLINE>, <VIN>

Transport Canada Recall: PENDING

Subject: URGENT SAFETY RECALL – DO NOT DRIVE YOUR VEHICLE
Safety Recall 40Q6 –Steering Knuckle(s)

Dear Volkswagen Owner,

This notice is sent to you in accordance with the requirements of the *Motor Vehicle Safety Act*. This is to inform you that your vehicle may contain a defect that could affect the safety of a person. Our records show that you are the owner of a vehicle affected by this action.

What is the issue? The steering knuckle(s) in affected vehicles may have been damaged during production. If a damaged steering knuckle is present in the vehicle, the steering may fail without warning, and increasing the risk of a crash.

Due to the safety risk, Volkswagen has issued a STOP DRIVE advisory.
DO NOT DRIVE YOUR VEHICLE.

What will we do? To identify/correct this defect, your authorized Volkswagen dealer will inspect and, if necessary, replace the steering knuckle(s). The inspection will take less than an hour. Replacement, if necessary, may take up to half a day to complete and will be performed for you free of charge. Please keep in mind that your dealer may need additional time for the preparation of the repair, as well as to accommodate their daily workshop schedule.

What should you do? **DO NOT DRIVE YOUR VEHICLE.** Contact VW Roadside Assistance immediately at 1 800-411-6688 to have your vehicle towed for FREE to your nearest Volkswagen dealer for a FREE inspection & repair. Your Volkswagen dealer will provide you with a loaner vehicle for FREE if needed.

Lease vehicles and address changes If you are the lessor and registered owner of the vehicle identified in this letter, you shall forward this letter (and any subsequent notice, if applicable) to the lessee within ten (10) days of receipt. If you have changed your address or sold the vehicle identified in this letter, please fill out the enclosed prepaid Owner Reply Card and mail it to us so we can update our records.

Can we assist you further? If your authorized Volkswagen dealer fails or is unable to complete this work free of charge within a reasonable time, please contact Customer Relations, Monday through Friday from 8AM to 8PM EST by phone at 1-800-822-8987 or via our "Contact Us" page at www.vw.ca

We apologize for any inconvenience this matter may cause; however we are taking this action to help ensure your safety and continued satisfaction with your vehicle.

Sincerely,

Volkswagen Customer Protection

Repair Overview

NOTE

To stay consistent with the ELSA Repair Manual and ETKA descriptions, the steering knuckle will be referred to as “wheel bearing housing” in these work instructions.



- Inspect left front and right front wheel bearing housings and replace if necessary.

NOTE

- These repair instructions may differ from the labor operations and labor times listed in ELSA.
- Damages resulting from improper repair or failure to follow these work instructions are the dealer's responsibility and are not eligible for reimbursement under this action.
- This procedure must be read in its entirety prior to performing the repair.
- Due to variations in vehicle equipment and options, the steps/illustrations in this work procedure may not identically match all affected vehicles.
- Diagnosis and repair of pre-existing conditions in the vehicle are not covered under this action.
- When working during extreme temperatures, it is recommended that the vehicle be allowed to acclimate inside the shop to avoid temperature-related component damage/breakage.

Required Tools

A green metal ball joint puller with two curved arms and a central threaded rod with a black handle.	<p>Puller - Ball Joint -3287A-</p> A green metal spreader tool with a cylindrical body and a threaded rod extending from one end.
A grey metal ball joint puller with a large, flat base and a central threaded rod with a black handle.	A drive shaft remover kit consisting of a purple plastic flange (1), a black metal rod (2), a purple plastic cap (3), a black metal pin (4), and a black metal sleeve (5).
A black metal engine and gearbox jack with a central threaded rod and a blue handle, mounted on a four-legged base with casters.	

Repair Instruction

Section A - Check for Previous Repair

TIP

If Campaign Completion label is present, no further work is required.

Applicable criteria ID(s)	Campaign/Action Status
01 ← 2	Open ← 1

EXAMPLE

Campaign/Action	Start	Designation
← 3	2015-11-10	W-SERV_ACT -
	2018-12-13	RECALL -
	2017-05-16	A-RECALL -

EXAMPLE

- Enter the VIN in Elsa and proceed to the “Campaign/Action” screen.

TIP

On the date of repair, print this screen and keep a copy with the repair order.

- Confirm the Campaign/Action is open <arrow 1>. If the status is closed, no further work is required.
- Note the Applicable Criteria ID <arrow 2> for use in determining the correct work to be done and corresponding parts associated.

CRITICAL REPAIR STEP



If multiple software update Campaign/Actions are open, they must be performed in order of the Start date <arrow 3>. The oldest should be performed first.

- **All Safety Recalls must be completed prior to completing this campaign.**
- **Proceed to Section B.**

Section B – Wheel Bearing Housing Inspection

NOTE

- Both front wheel bearing housings must be inspected.
- The following describes the inspection procedures for one side of the vehicle. Inspection on the opposite side is similar.

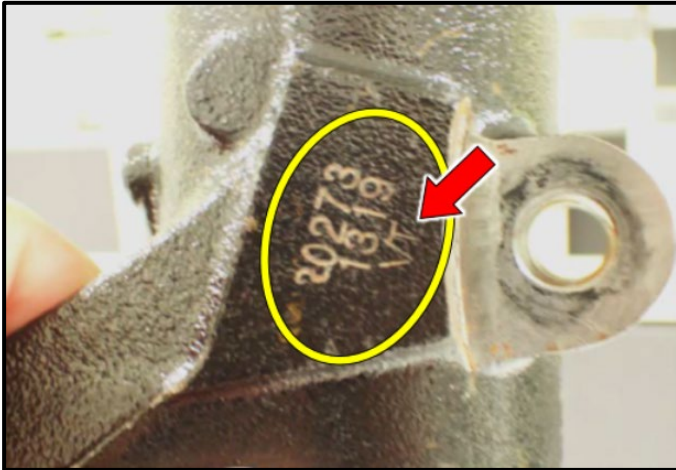

- Raise vehicle on hoist.
- Locate the production stamping on the wheel bearing housing <circle>.
- If the manufacturer code “VT” is NOT present on both wheel bearing housings:
 - No further work is required.
 - Proceed to Section D.
- If the manufacturer code “VT” IS present on either wheel bearing housing:
 - **THE VEHICLE MUST NOT BE RETURNED TO THE CUSTOMER OR DRIVEN!!**
 - The affected wheel bearing housing must be replaced.
 - Proceed to Section C.

Section C – Replacing Wheel Bearing Housing

NOTE

The following describes the removal and installation procedures for one side of the vehicle. Removal and installation on the opposite side is similar.

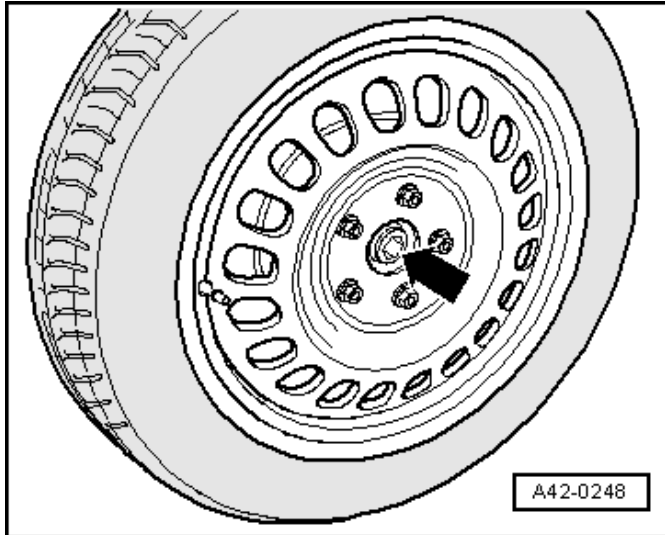

Loosen front drive axle bolt:

- Secure the front wheels from turning.
- Loosen the front axle bolt <arrow>.

CAUTION

- The wheel bearing must not be under load when the drive axle threaded connection on the wheel side is loose.
- If the wheel bearings are under the load of the vehicle weight, the wheel bearing will be damaged. This reduces the service life of the wheel bearings.
- The drive axle bolt may be loosened maximum 90° when the vehicle is standing on its wheels.
- Vehicles without a drive axle must not be moved, otherwise the wheel bearing will be damaged. If a vehicle must be moved, be sure to note the following:
 - Install an outer joint in place of the drive axle.
 - Tighten the outer joint to 120 Nm.

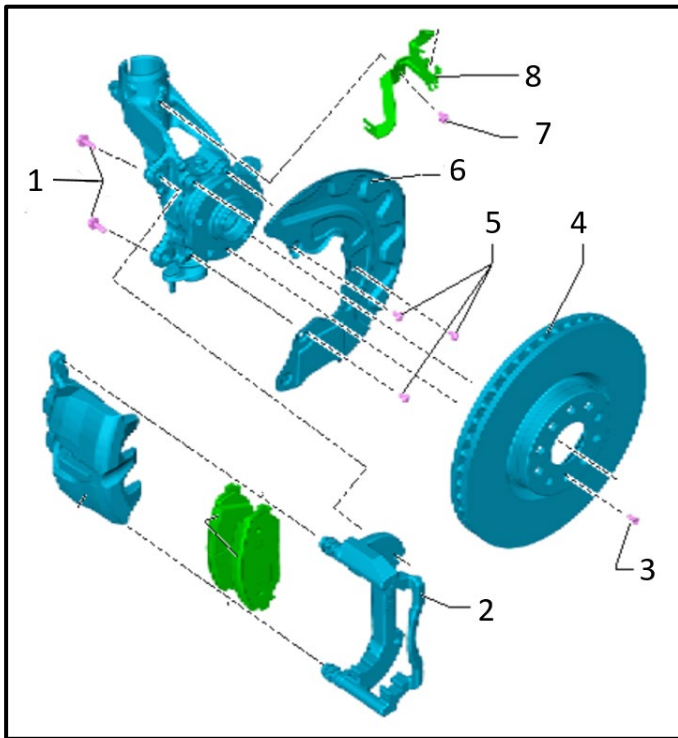

Remove brake components:

- Remove front wheel.
- Remove bolts <1> from the brake caliper carrier <2>.
- Remove brake caliper carrier <2> and secure it using wire to prevent damage to the brake hose.
- Remove bolt <3> and brake rotor <4>.
- Remove bolts <5> and backing plate <6>.
- Remove bolt <7> and secure bracket <8> out of the way.
- Free up wires from the wheel bearing housing.

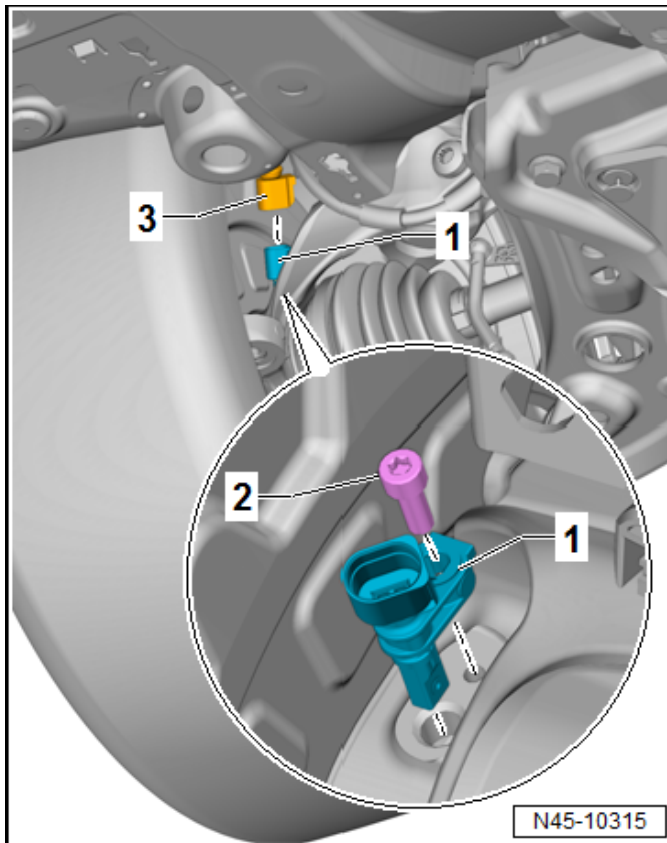

Remove ABS wheel speed sensor:

- Disconnect connector <3>.
- Remove bolt <2>.
- Remove ABS wheel speed sensor <1>.

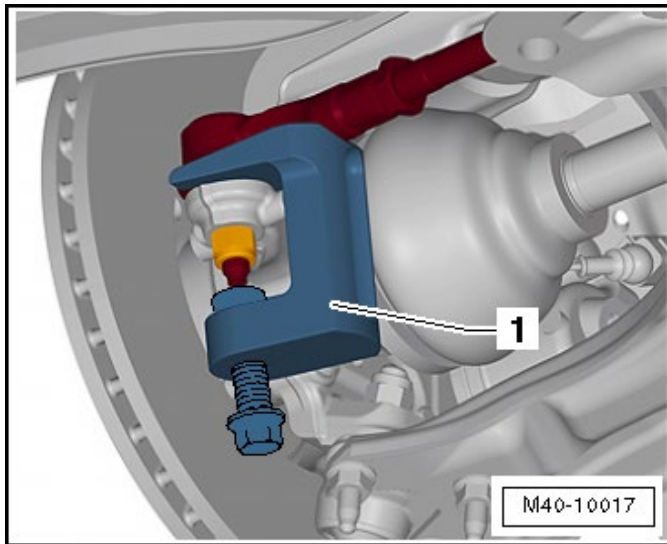

Remove tie rod end from wheel bearing housing:

- Loosen the nut from the tie rod end, but do not remove it yet.
- Install Puller – Ball Joint -T10187- <1> as shown.
- Tighten bolt using hand tools on -T10187- until tie rod end is pressed off the wheel bearing housing.

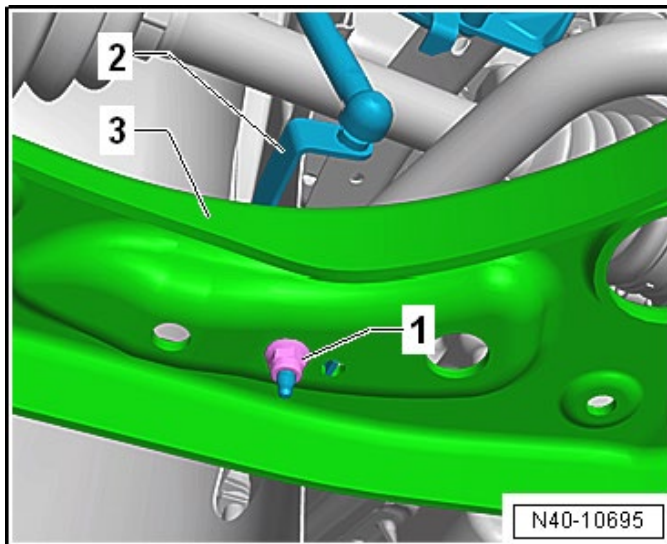

Remove level sensor bracket from control arm (if equipped):

- Remove nut <1>.
- Remove bracket <2> from control arm <3>.

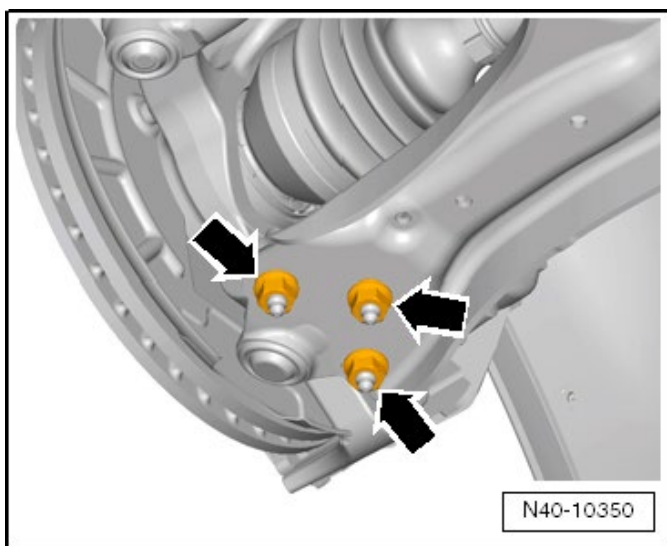

Remove wheel bearing housing from control arm:

- Remove nuts <arrows>.
- Press the drive axle outer joint out of the wheel bearing by hand.

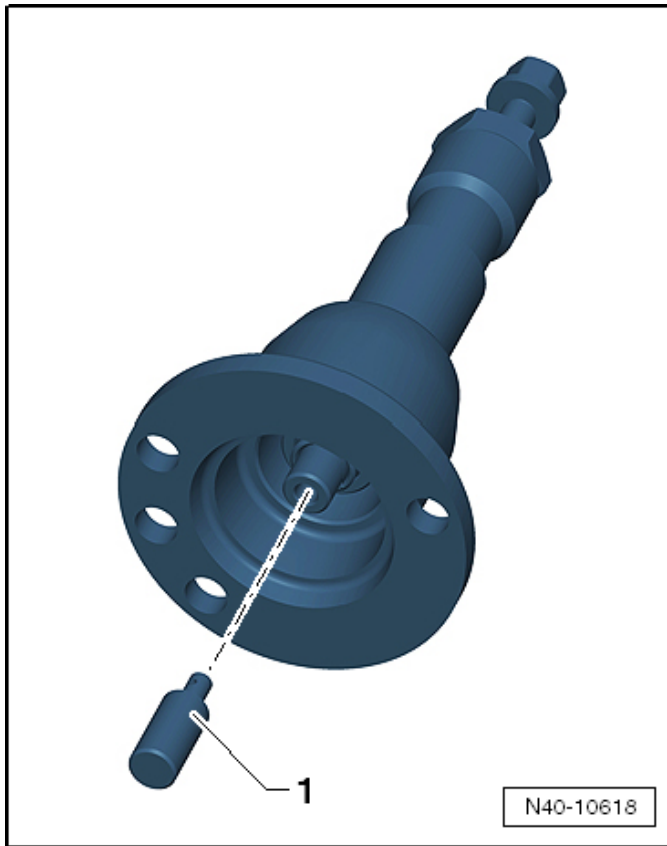

If the Drive Axle Cannot Be Pulled out of the Wheel Bearing, Then the Drive Axle Can Be Pushed out of the Wheel Bearing Using the Drive Shaft Remover -T10520A- as follows:

- Before using the -T10520A-, make sure that the thrust piece <1> is installed.

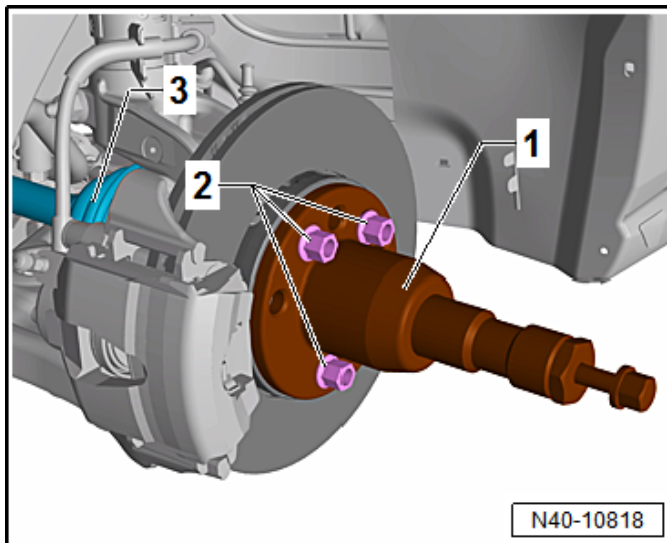

- Secure the -T10520A- <1> with three wheel bolts <2> on the wheel hub, so that the drive axle <3> can be pressed out.

NOTE

The brake rotor may have to be reinstalled temporarily.

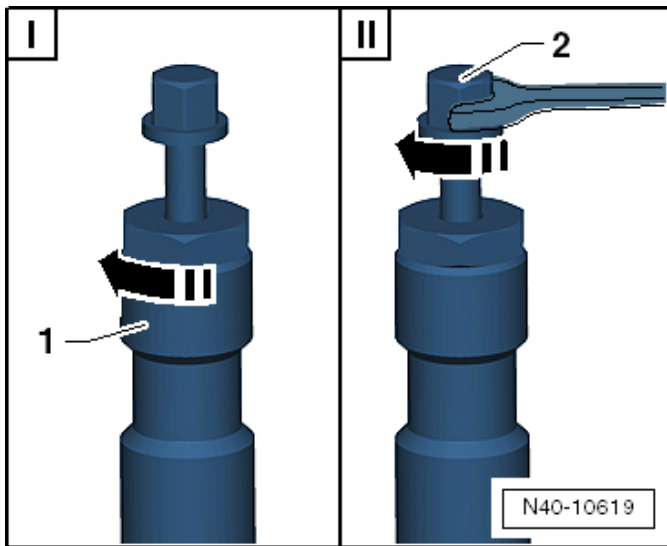

- Follow the specified sequence exactly.
 - I - Tighten the knurled nut <1> hand-tight.
 - II - Turn the bolt <2> using a wrench and press out the drive axle using the -T10520A-. DO NOT use power tools on bolt <2>.

NOTE

After the tool is used, the spindles must be brought back into the original position so that the hydraulic operation can be used again.

- Secure the drive axle to the body using a wire.

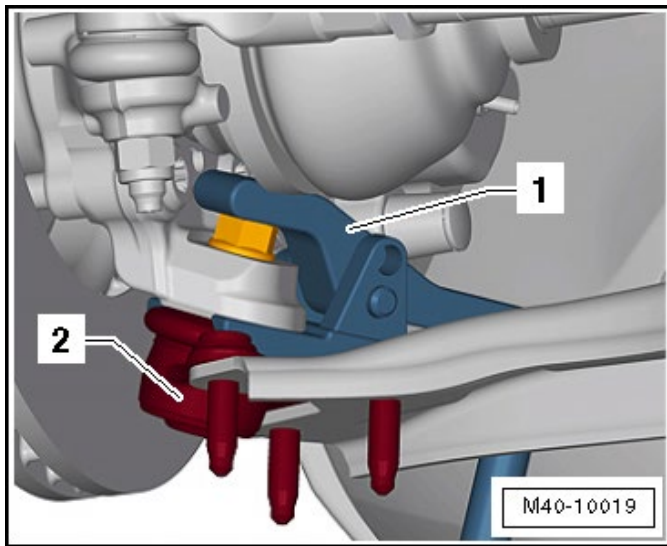

Remove ball joint:

NOTE

Depending on the supplier of the part, the ball joint may already be pre-installed on the wheel bearing housing. If so, ignore this step.

- Loosen the nut on the ball joint <2> but do not remove it.
- Install Puller – Ball Joint -3287A- <1> as shown.
- Tighten bolt using hand tools on -3287A- until ball joint is pressed off the wheel bearing housing.
- Remove the ball joint nut and remove the ball joint.

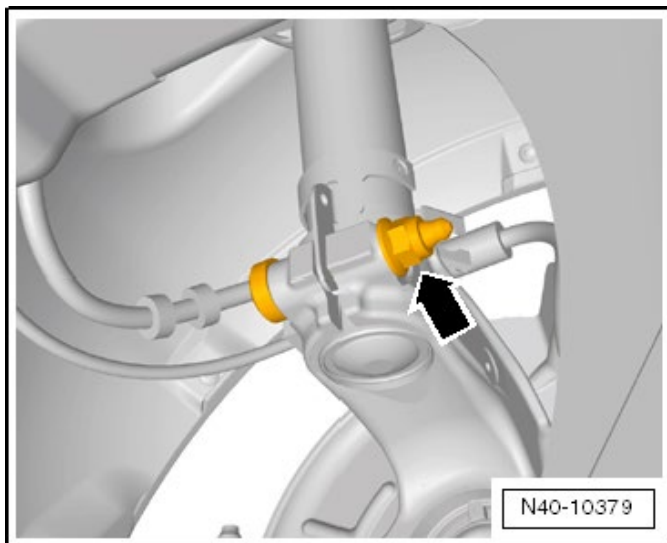

Remove wheel bearing housing:

- Place the -VAS6931- under the wheel bearing housing.
- Remove the threaded connection on the wheel bearing housing/suspension strut <arrow>.

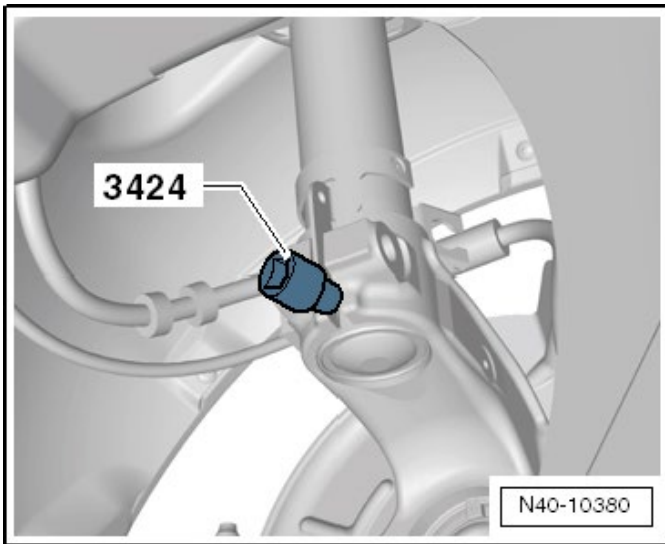

- Insert -3424- into the wheel bearing housing.

NOTE

Pay attention that the -3424- is only inserted in the wheel bearing housing. Only insert it far enough that the suspension strut metal retainer is not damaged.

- Turn the ratchet 90° and remove it from the -3424-.
- Remove the wheel bearing housing downward from the suspension strut.

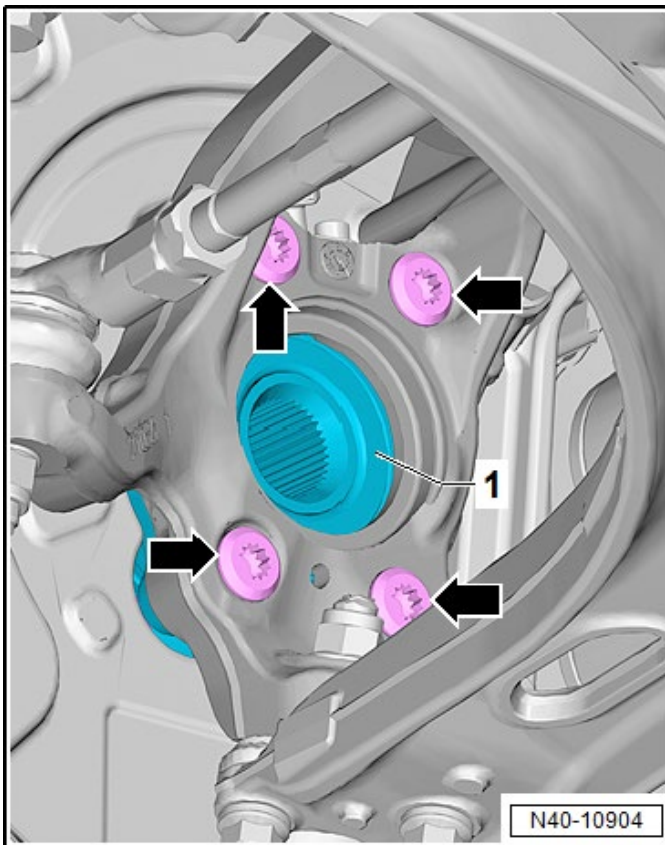

Install new wheel bearing into wheel bearing housing:

NOTE

Depending on the supplier of the part, the wheel bearing may already be pre-installed in the wheel bearing housing. If so, ignore this step.

- Install new wheel bearing into wheel bearing housing with new bolts <arrows>.
- Torque bolts <arrows> to 70 Nm + 90°.

Part Number	Part Description
3QF-598-625	Wheel Bearing

NOTE

A new wheel bearing kit includes new mounting bolts <arrows> and a new drive axle bolt. If the new wheel bearing housing used during this repair comes with the wheel bearing pre-installed, a new drive axle bolt will be required.

NOTE

Avoid contaminating with dirt and damaging the seal <1> when lifting, setting down/storing.

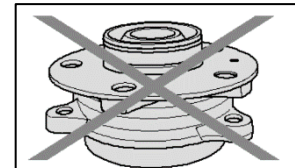

Always set the wheel bearing unit down on the wheel hub <2>.

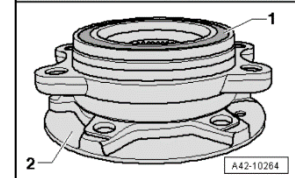

The repair information in this document is intended for use only by skilled technicians who have the proper tools, equipment and training to correctly and safely maintain your vehicle. These procedures are not intended to be attempted by "do-it-yourselfers," and you should not assume this document applies to your vehicle, or that your vehicle has the condition described. To determine whether this information applies, contact an authorized Volkswagen dealer. ©2020 Volkswagen Group of America, Inc. and Volkswagen Canada. All Rights Reserved.

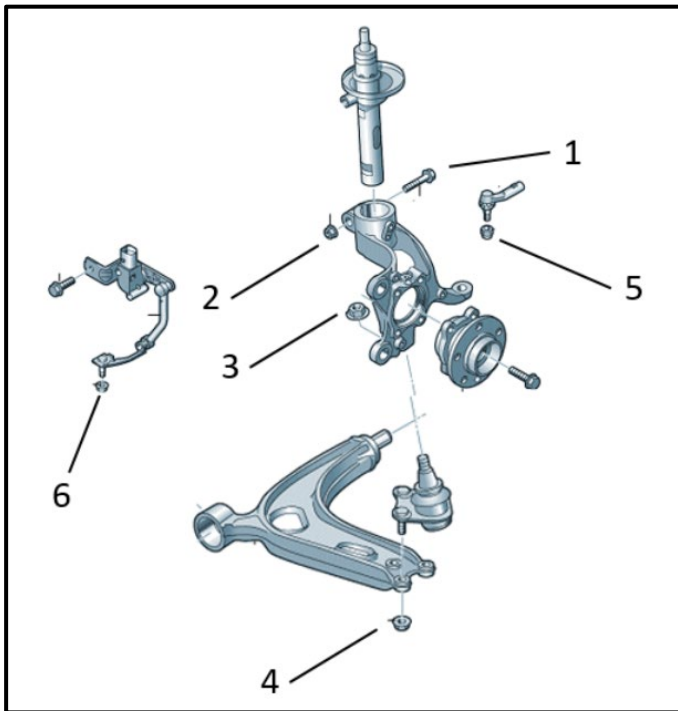

Install new wheel bearing housing:

- Installation is the reverse order of removal.
- Install new bolt <1> and new nut <2>.
 - The bolt tip must point in direction of travel.
- Remove -3424- after installing wheel bearing housing onto strut and installing new bolt and nut.
- Counter hold new bolt <1> and torque new nut <2> to 70 Nm + 180°.
- Counter hold ball joint stud. Install and torque new nut <3> to 60 Nm.

NOTE

Wheel bearing assembly part numbers 3QF-498-998 and 3QF-498-998-A have the ball joint pre-installed. Bolt <3> will not be required.

- Install and torque new nuts <4> to 40 Nm + 45°.
- Install tie rod end into wheel bearing housing.
- Counter hold tie rod end stud. Install and torque new nut <5> to 20 Nm + 90°.
- If equipped, install level sensor arm into control arm. Install new nut <6> and torque to 8 Nm.
 - The level control system sensor lever must point toward vehicle exterior.
 - The thread on the level control system sensor must be installed into the exterior hole in the control arm. The retaining tab on the level control system sensor must engage into the inner hole in order to assure a correct installation position.

Pos.	Part Number	Part Description
1	N -909-548-02	Bolt – wheel bearing housing to strut
2	N -101-064-02	Nut – wheel bearing housing to strut
3	N -909-429-02	Nut – ball joint to wheel bearing housing
4	N -912-332-01	Nuts – ball joint to lower control arm (x3)
5	N -909-429-02	Nut – tie rod end to wheel bearing housing
6	N -102-058-02	Nut – level sensor to control arm

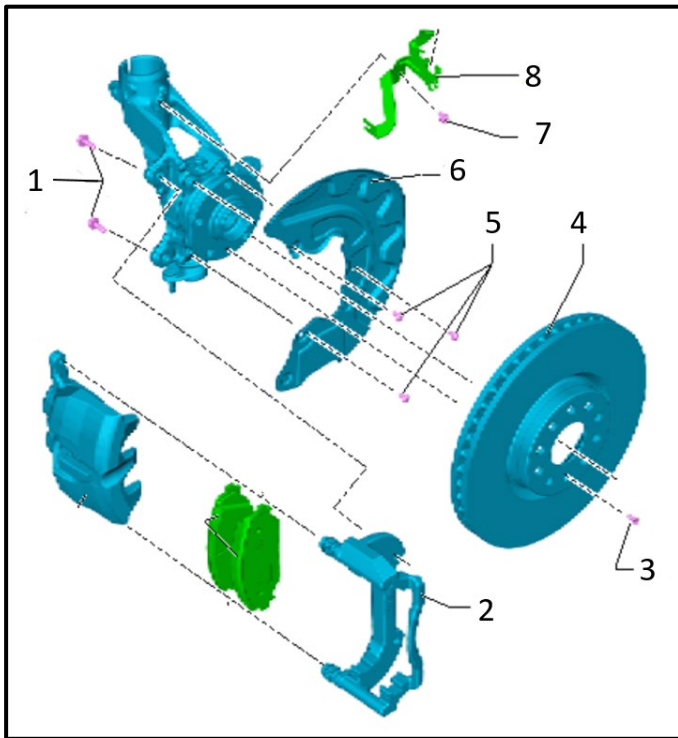

Reinstall brake components:

- Installation is the reverse order of removal.
- Torque fasteners as follows:
 - Backing plate nuts <5> - 12 Nm.
 - Rotor bolt <3> - 8 Nm.
 - Brake hose bracket bolt <7> - 8 Nm.
 - Brake caliper carrier bolts <1> - 200 Nm.
 - Clean bolts and mounting surfaces before installing.
 - Wheel bolts – 120 Nm.
 - Leave wheel center cap off.
- Install ABS wheel speed sensor and torque bolt to 8 Nm.
 - Before inserting the speed sensor, clean the inner surface of the hole and coat speed sensor all-round with Hot Bolt Paste -G 052 112 A3- (shop supply).

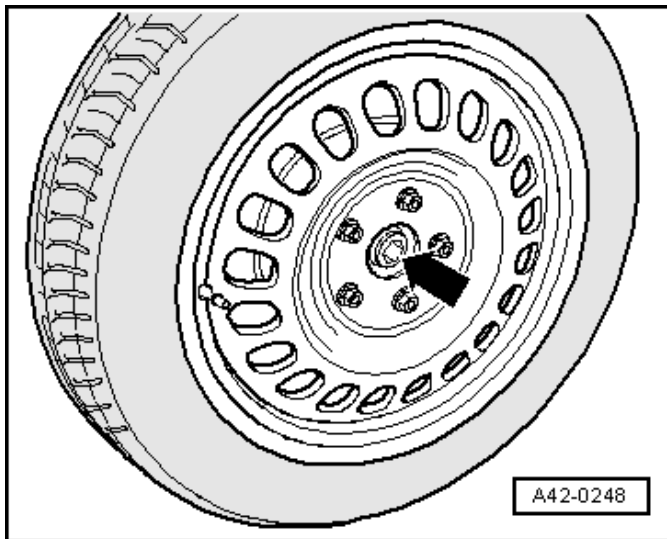

Install drive axle bolt:

- Press the brake pedal. A second technician will be needed.
- Tighten the twelve-point bolt to 200 Nm.
- Set the vehicle on its wheels.
- Tighten the twelve-point bolt an additional 90°.

! NOTE

A new wheel bearing kit includes a new drive axle bolt. If the new wheel bearing housing used during this repair comes with the wheel bearing pre-installed, a new drive axle bolt WHT-005-437-A will be required.



Perform four-wheel vehicle alignment:

- Follow the ELSA Repair Manual and wheel aligner equipment directions as needed.
- Was the rear axle toe adjusted?
 - If YES, proceed to the next step.
 - If NO, Proceed to Section D.

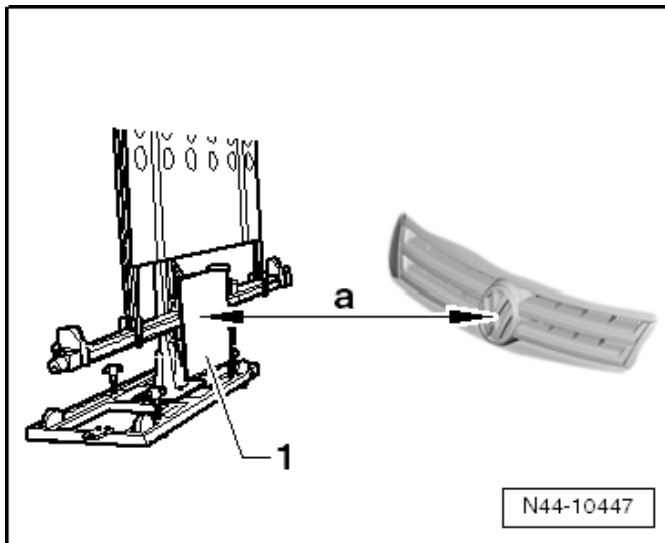

Calibrate driver assist systems depending on vehicle equipment:

- Calibrate *Adaptive Cruise Control (ACC)* only if rear axle toe required adjustment.
- Calibrate *Driver Assistance Systems Front Camera* only if rear axle toe required adjustment.
- Follow the ELSA repair manual procedures, GFF test plan directions and wheel aligner software directions as needed.

Proceed to Section D.

Section D – Campaign Completion Label

Install Campaign Completion Label

- Fill out and affix Campaign Completion Label, part number CAMP 010 000, next to the vehicle emission control information label.



TIP

Ensure Campaign Completion Label does not cover any existing label(s).

Proceed to Section E

Section E - Parts Return/Disposal

Properly store (retain), destroy or dispose of removed parts in accordance with all state/province and local requirements, unless otherwise indicated and/or requested through the Warranty Parts Portal (WPP) for U.S. and the Part Destruction and Core Disposition Report for Canada.