



Thor Motor Coach Recall Repair Instructions

Recall #	20V-679 2020-527		
Description/Title:	Iota ITS-50R Transfer Switch – Expanded Scope		
Affected Product Line(s):	Certain Model Year 2010-2011 Montecito motorhomes		
Service Campaign # :	RC000202	Released Date:	12/15/2020
Repair Code:	Inspect Only: TMCRC80496Y Replace: TMCRC80496V	Document Date:	12/15/2020
Time Allowed:	Inspect Only: 0.2 Replace: 1.0	Document Revision:	A

Issue:

All of the motorhomes subject to this recall campaign are equipped with an Iota ITS-50R transfer switch, which may be experiencing heat related failure when exposed to elevated electrical loads associated with RV use in higher ambient temperatures. The connections at the buss bar inside of the switch are not adequate resulting in elevated operating temperatures.

Parts Required for Repair:

TMC Recall Kit #**0491521**
Kit Includes: Furrion F50-ATS

Inspect Instructions:

Verify if the motorhome has the Iota ITS-50R transfer switch installed.
If it has already been replaced by another brand, no further action is necessary.
If needing replaced, continue onto repair instructions.

Repair Instructions:

Replace the transfer switch. Make sure all connections are properly secured.
See Furrion’s attached instructions on how to properly install the new F50-ATS.

FURRION

F50-ATS

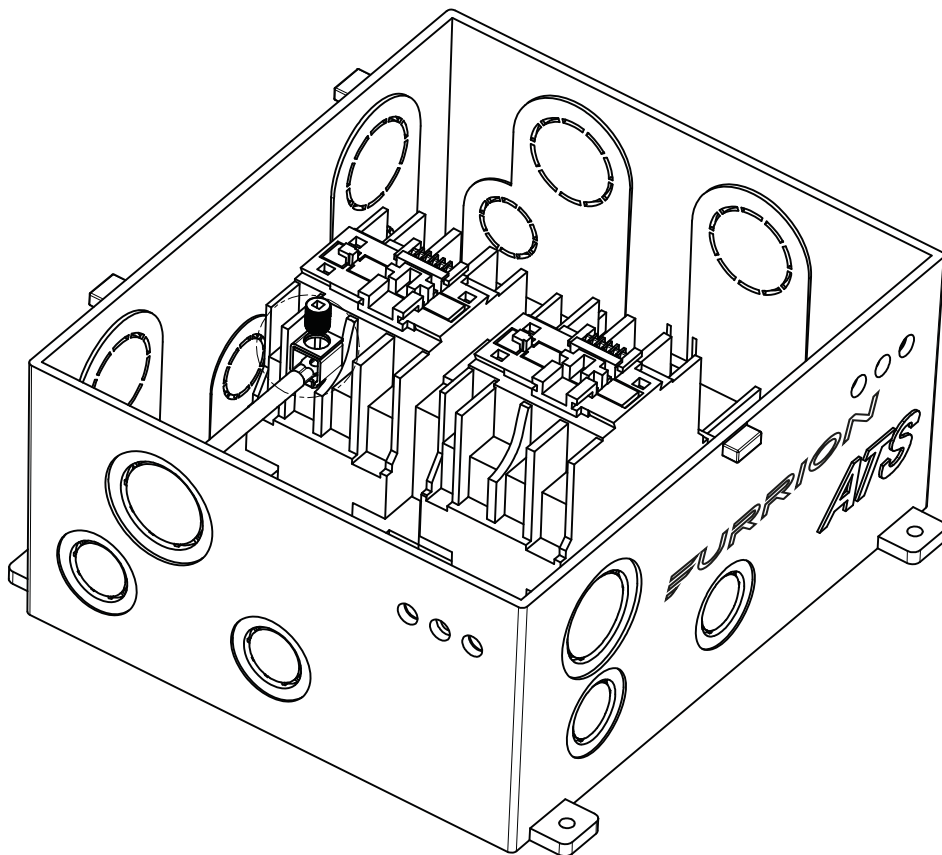

50amp 125/250V Automatic Transfer Switch

Furrions ATS is used to safely switch automatically between mutiple power sources

Furrion's 50amp Automatic Transfer Switch with built in safe switch interlock system is used to automatically switch between two separate 125/250 volt AC power sources, these power sources can be from a Generator, shore power cord or inverter.

The function of the Furrion Automatic Transfer Switch is to provide a safe and smooth switch over from an inverter or shore power cord automatically when a generator is started and brought online, the Furrion ATS offers the added feature of a mechanical interlock between contactors to ensure both contactors cannot be closed in parallel which could otherwise create an over voltage situation on the output line.

The electrical contacts in the transfer switch are normally in the open position, once AC voltage is applied to input 1 this will automatically close the contacts in contactor 1 and feeds the output line from the shore power cord or inverter. Once AC power from the Generator is sensed by the transfer switch at Input 2 terminals, this will start a timer and automatically switch over to generator power supply after a 20-30 second delay which ensures the generator has sufficient time to run up to speed before electrical load is applied.

PLEASE READ ALL SAFETY INSTRUCTIONS BEFORE INSTALLING THIS TRANSFER SWITCH!

WHEN PROTECTED BY A MOLDED CASE CIRCUIT BREAKER RATED TO 50AMPS OR LESS, THIS LINE/GENERATOR SWITCH IS RATED TO 5000 SYMMETRICAL AMPS.

BEFORE PREFORMING MAINTENANCE OR INSTALLATION PLEASE ENSURE TO ISOLATE ALL POWER SOURCES!

- ! Ensure generator is shut off and auto start feature (if applicable) is isolated.
- ! Confirm external power cord is disconnected and stored in an area where it cannot mistakenly be plugged in.
- ! Confirm the inverter (if used) has been disconnected.
- ! Confirm with an AC/DC electrical tester that no voltage is present at any of the connections before beginning installation or maintenance.
- ! Label all electrical parts with a warning tag to show work is in progress before beginning work.

Furrion warranties this transfer switch in the Continental United States of America and Canada from defects in materials or workmanship under normal use for 1 year from date of purchase.

INSTALLING YOUR F50-ATS:

There are 3 common installation configurations for the Furrion ATS series:

Configuration 1: Double power feed

This is the standard installation used between a shore power cord and generator.

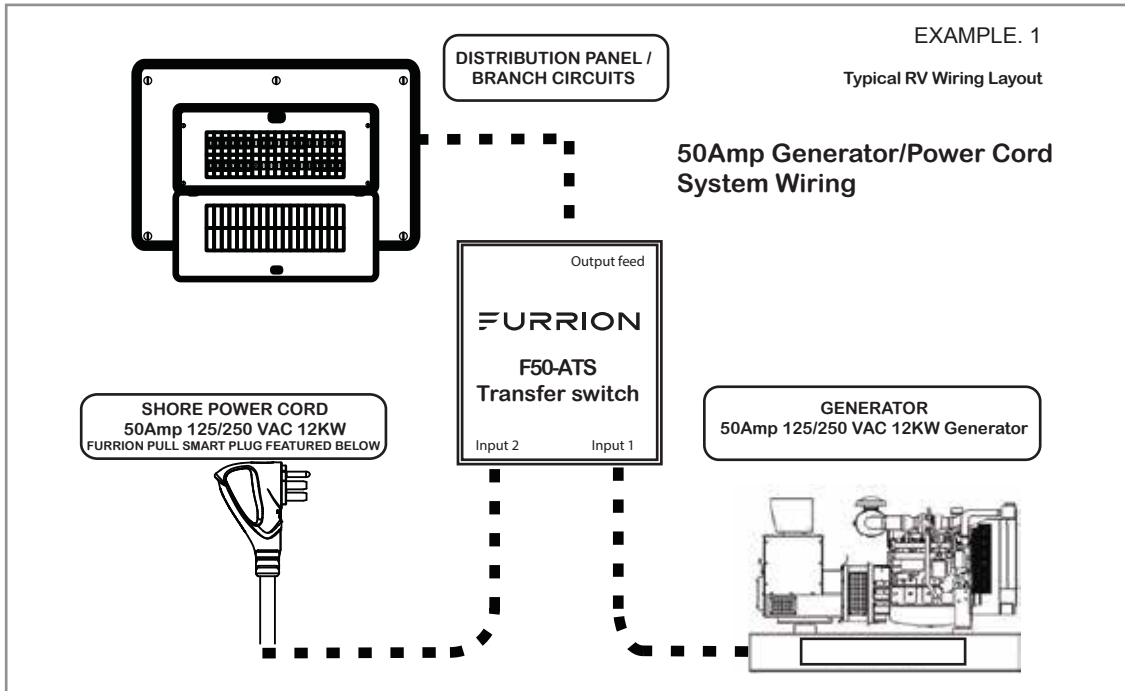

Configuration 2: Triple power feed (same rating)

This configuration is used when a inverter is added to the system and requires automatic switch over. See Diagram 2 which illustrates this configuration

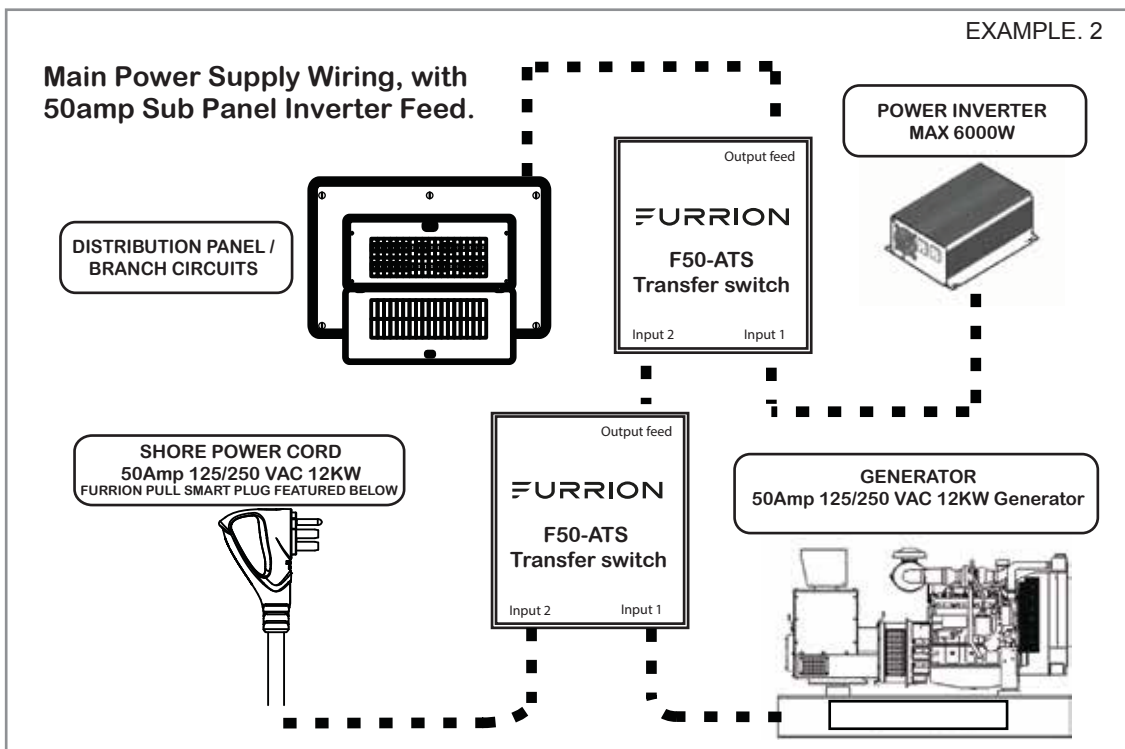

Configuration 3: Triple Power Feed (double distribution panel)

This configuration is used when it is required for multiple power sources to feed sub distribution panels

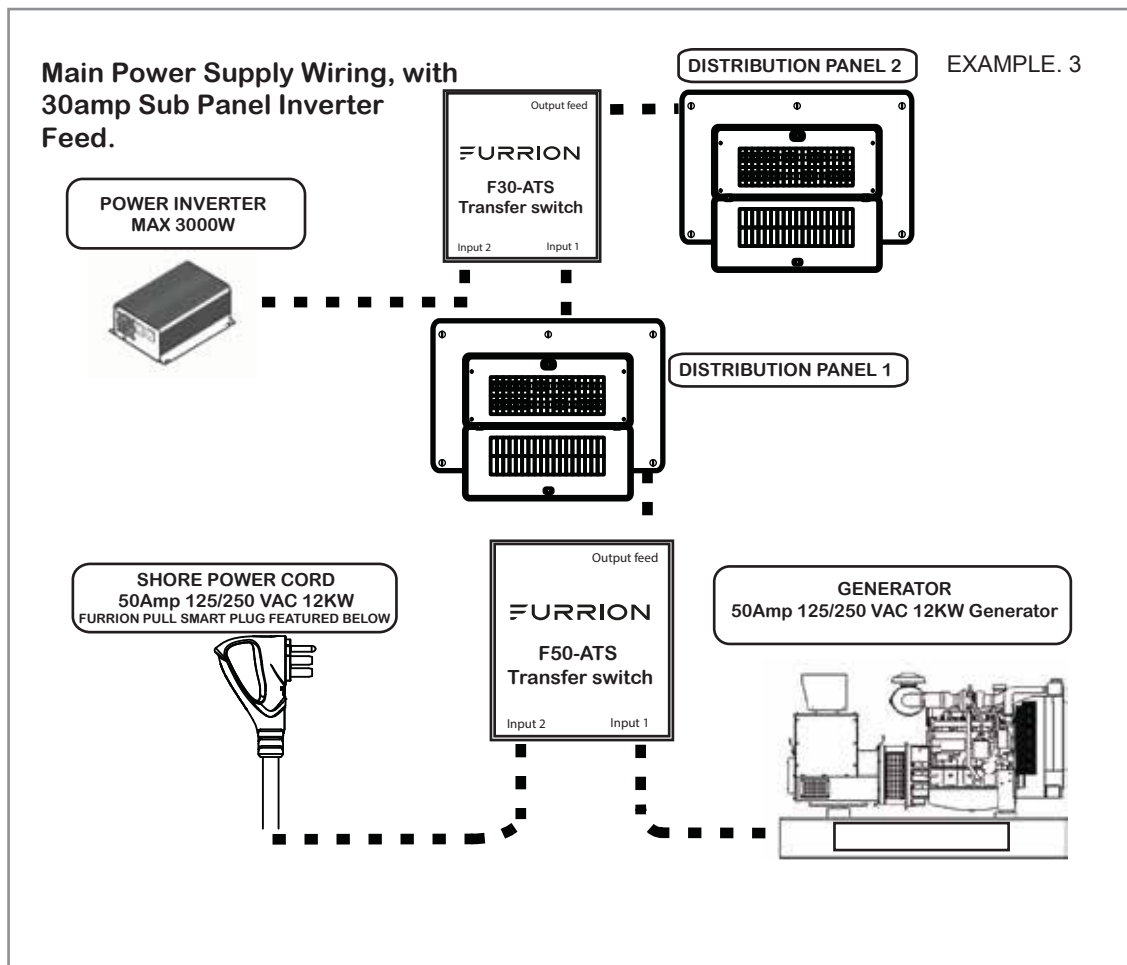

Warning:

The Furrion F50-ATS is not suitable to be used with Medical life support equipment.

For mounting and installing the transfer switch you will require:

- 3 x 1" Cable strain relief's
- 4 x Self tapping screws with a minimum length of 30mm to mount ATS box
- 1 x Torque screw driver with square head #2
- 1 x Philips screw driver #2

MOUNTING YOUR F50-ATS:

The Furrion ATS is best mounted indoors or in a location sheltered from outdoor elements. The selected area must be free from the possibility of contaminants and away from water pipes, pumps, battery compartments and storage areas for flammable liquids.

Do not mount the ATS in an engine compartment.

The ATS mounting location must be accessible after installation is complete to facilitate future servicing, if possible mount the ATS close to power cord Point of entry or generator output.

Typical examples of mounting locations are:

Inside seat or bed compartments

Above or behind cabinets'

Under floor storage compartments, etc.

To mount the ATS box the 4 screw lugs on the outside of the box can be used to secure, the ATS box also has an alternative 4 screw holes inside the box which can also be used.

Punch out 3 of the large diameter cable strain holes on the side of the box in the directions which the cables will be fed from using a blunt object. Ensure to remove all plastic pieces of the punch out cable strain holes by rotating the ATS box upside down.

Hold the transfer switch to the desired position and using 4 self-tapping screws secure the transfer switch box. Ensure the switch is securely mounted so it cannot move or vibrate

Once the ATS is securely mounted then screw in the 3 cable strains into the punch out holes and back off the cable strain screws.

WIRING YOUR F50-ATS:

50amp 125/250VAC Wiring

Ground = Bare copper wire or green

Neutral = White

Live/Hot L1 = Black

Live/Hot L2 = Red

50amp 125VAC Wiring

Ground = Bare copper wire or green

Neutral = White

Live/Hot = Black

Using the quick reference wiring guide on the lid of the ATS box, arrange the wires to be fed into the ATS for connection at the corresponding terminals.

Generator in

Shore Power in

Line/feed out

Ensure to feed the wires through the cable strains when they enter to ATS box. Shore power and generator cables should be fed into the ATS from the side marked on the box sticker.

The line out wires will enter the ATS from the opposite side.

See below diagram for wiring layout.

Strip 4" of outer jacket from each of the incoming cables.

Strip ½" of jacket from each of the wire conductors.

Connect the colored wires to the ATS terminals using the diagram above

Using your #2 (Robertson's) square head torque Screwdriver, tighten the terminal screws to 20in-lb minimum and 25in-lb maximum

Connect the chassis grounding 8AWG wire to the grounding terminal block on the inside of the transfer switch box. Use the 3/8" through hole to feed the wire through from the outside of the box directly to the terminal block.

Using your #2 Square Head Torque Screwdriver, tighten the grounding block terminal screws to 20in-lb minimum and 25in-lb maximum.

PLEASE READ THE FOLLOWING SAFETY INSTRUCTIONS...

Follow the below steps to test the function of the F50-ATS.

BEFORE TESTING:

Ensure air conditioning units and other high current users are switched off. It is harmful for the transfer switch to switch over power sources while under load.

Shut down all power sources to the RV

Label power sources clearly that testing is in progress.

If accessible, remove the lid of the ATS to visually check function.

ATS FUNCTION TESTING:

1. Plug in the shore power cable and turn on the dockside shore power breaker, as soon as the shore side breaker is turned on you will hear a clunk noise immediately as the shore power contactor engages inside the ATS, power is then supplied to the RV from the ATS line out feed.

2. Turn off the shore side power breaker to shut down power to the RV, you will hear a clunk as the Shore power contactor disconnects (keep the shore power cord connected with no power for further testing).

3. Start the Generator in the RV and wait for it to run up to speed, as soon as power is fed to the ATS from the generator the green LED indicator light on the internal ATS PCB will illuminate, the ATS has a 20-30 second time delay before engaging the internal contactor to allow for the generator to warm up. After 20-30 seconds you will hear a clunk noise as the generator contactor engages inside the ATS, power from the generator is now supplied to the RV from the ATS line out feed.

4. Shut down the generator

ATS SWITCHING TESTING:

To test the switching function after both function tests have passed:

1. Turn on the shore cord shore side breaker to engage the shower power contactor, power is now being supplied to the RV by the shore power.

2. Start the generator and wait for it to warm up, after 20-30 seconds you will hear a clunk as the unit automatically switches over power sources from shore power to generator.

3. Turn off shore power from the shore side breaker and confirm the generator is feeding the line out, the power supply should not be interrupted by doing this.

4. Turn on the shore power shore side breaker again which will engage the shore power contactor. While the shore power is still connected and on, then turn off the generator, this will then disengage the generator contactor and automatically switch to running on shore power feed.

TROUBLESHOOTING YOUR F50-ATS:

In the event of a problem with your F50-ATS, contact a qualified electrician for advice.

COMMON PROBLEMS:

Transfer switch will not switch over from Shore Power to Generator feed.

Possible cause: Bad PCB.

How to check: Open the transfer Switch lid so the PCB is visible, do not put your hands or touch anything inside the box.

Turn on the generator so electric is being fed to the ATS, using a multi meter check for correct voltage at the incoming generator wiring terminals.

If the correct power is being fed to the ATS from the Generator the ATS PCB's the green LED illuminated. After 30 seconds if the contactor does not close

If the PCB's green LED is not illuminated while generator voltage is present indicates the PCB has been damaged and will need replaced.

Contact your nearest Furrion Dealer, RV OEM or email support@furrion.com

POSSIBLE CAUSES FOR F50-ATS PROBLEMS:

INGRESS OF FOREIGN OBJECTS INSIDE ENCLOSURE:

Reasons:

Poor installation can cause wood chippings, sawdust, metal filings, or other foreign matter to enter the case.

Unsuitable mounting position can cause condensation, moisture or dirt to enter the enclosure,

Potential Damage: Contactor does not function properly, burned out coils, Metal particles can cause fire or short the PCB.

FLUCTUATING POWER OR POWER SPIKES:

Reasons:

Lighting strikes,

Unbalance load at park,

Park Black outs

Utility service at park is undersized or located next to an industrial environment.

Potential Damage: burnt out contactor coils, PCB damage, pitted contacts, further damage to the RV.

LOW VOLTAGE POWER SUPPLY:

Reasons:

Bad or corroded electrical connection,

Extension cord length too long

Operating too much load for power available.

Park power supply insufficient

Potential Damage: Pitted contacts, burnt out contactor coils, further damage to the RV.

GENERATOR FEED:

Reasons:

Generator requires maintenance,

Generator Governors or throttle problems

Generator Auto Start/Stop failure.

Potential Damage: Burnt out contactor coils, PCB damage, pitted contacts, further damage to the RV.

There are 2 options for mounting the Furrion F50-ATS:

Option One: Using the external lugs which are located on the outside of the box.

Mounting dimensions for the external lugs are:

Outer Lugs : 189 x 220mm ($7\frac{7}{16}$ x $8\frac{11}{16}$)

Option Two: Using the 4 x internal holes which are located on the inside of the box.

Mounting dimensions for the internal holes are:

Internal holes: 160 x 130mm ($6\frac{5}{16}$ x $5\frac{1}{8}$)

