

TECHNICAL INSTRUCTIONS

FOR

SAFETY RECALL 20TA14

POTENTIAL IMPROPER DEPLOYMENT OF SEAT MOUNTED SIDE AIR BAG

CERTAIN 2020 HIGHLANDER

The repair quality of covered vehicles is extremely important to Toyota. All dealership technicians performing this recall are required to successfully complete the most current version of the E-Learning course “Safety Recall and Service Campaign Essentials”. To ensure that all vehicles have the repair performed correctly; technicians performing this recall repair are required to currently hold at least one of the following certification levels:

- Certified Technician (any specialty)
- Expert Technician (any specialty)
- Master Technician
- Master Diagnostic Technician

It is the dealership’s responsibility to select technicians with the above certification level or greater to perform this recall repair. Carefully review your resources, the technician skill level, and ability before assigning technicians to this repair. It is important to consider technician days off and vacation schedules to ensure there are properly trained technicians available to perform this repair at all times.

I. OPERATION FLOW CHART

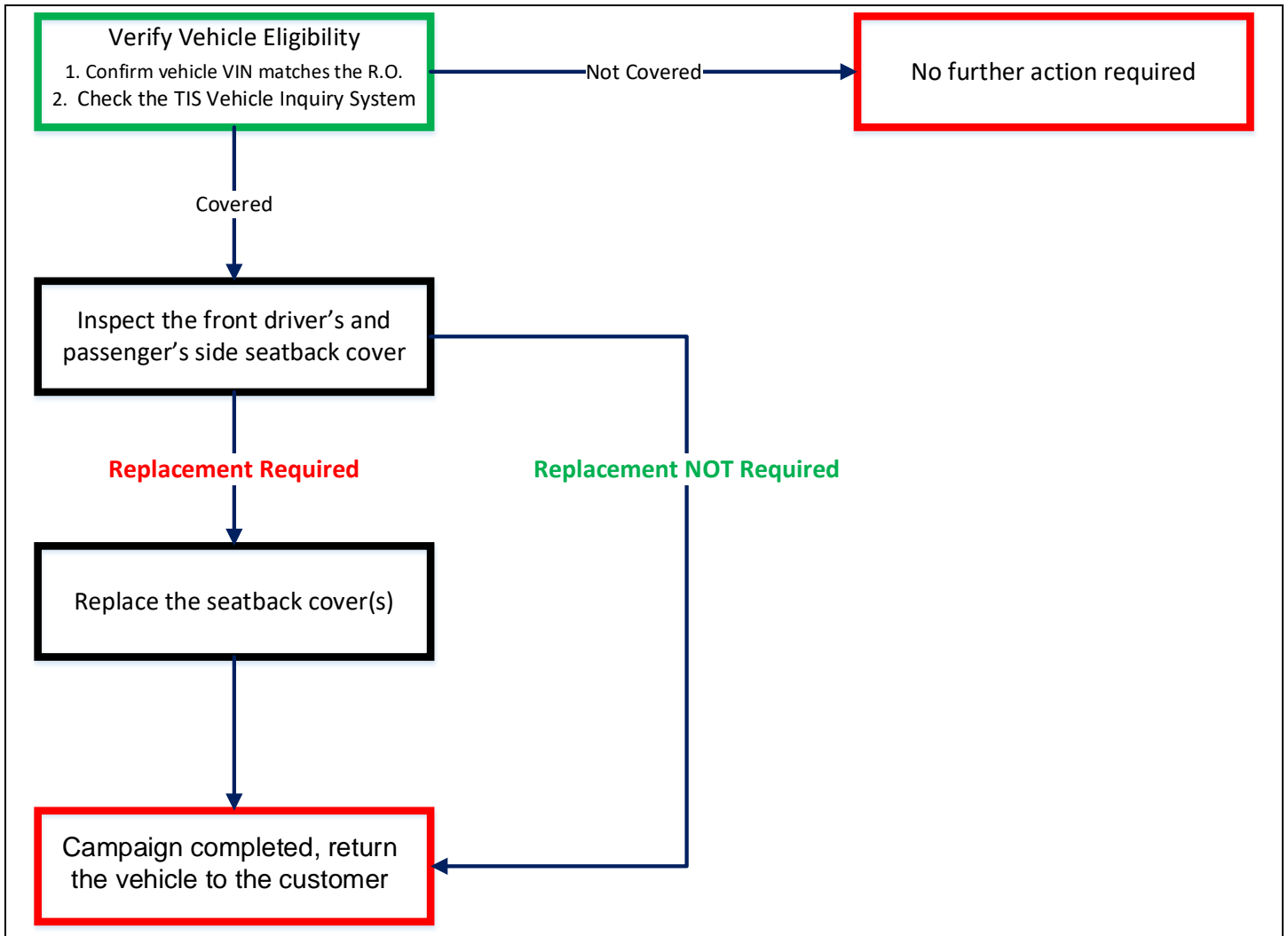

II. IDENTIFICATION OF AFFECTED VEHICLES

1. CHECK VEHICLE FOR CAMPAIGN ELIGIBILITY

- Compare the vehicles VIN to the VIN listed on the Repair Order to ensure they match.
- Check the TIS Vehicle Inquiry System to confirm the VIN is involved in this Campaign, and that it has not already been completed.

Note: TMNA warranty will not reimburse dealers for repairs completed on vehicles that are not affected or were previously completed, even by another dealer.

III. PREPARATION

A. PARTS

If the inspection performed in Section VI determines seat cover(s) replacement is necessary, use the Electronic Parts Catalog (EPC) to order the correct service part for seat cover replacement

B. TOOLS & EQUIPMENT

- Techstream
- Standard Hand Tools
- Torque Wrench

IV. BACKGROUND

There is a possibility that one or both of the front seats in the subject vehicles were equipped with an incorrect trim cover. If these trim covers are incorrect, the cover could prevent the seat-mounted side air bag from deploying properly when the air bags are commanded to deploy, increasing the risk of injury in the event of a crash.

V. SAFETY PRECAUTIONS

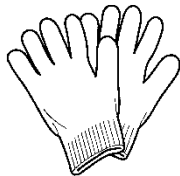
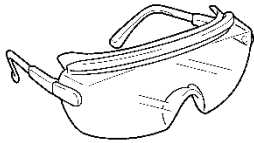

Wear protective eye wear and work gloves.

1. WEAR PROTECTIVE EQUIPMENT

- a) Wear appropriate protective equipment when working on the seat.

VI. INSPECTION

1. INSPECT DRIVER'S FRONT SEAT FOR CORRECT SEAT COVER

- From behind the front driver seat, inspect the lower seat carpet for a plastic patch by removing the carpet from the seat side trim panels as shown below.
- Confirm which side the plastic patch is on.
- Note: The plastic patch will either be on the outboard or inboard side.



Use your hand to feel for the plastic patch as it may be hard to see on certain seat colors



DRIVER SEAT INSPECTION

Outboard side by
driver's door

Which side is the plastic patch on?

Inboard side
by console

NG
Seat cover replacement **IS**
REQUIRED for the drivers seat. Move
onto passenger seat inspection

OK
Move onto passenger seat inspection

2. INSPECT PASSENGERS FRONT SEAT FOR THE CORRECT SEAT COVER

- From the behind the front passenger seat, inspect the lower seat carpet for a plastic patch by removing the carpet as you did for driver's seat.
- Confirm which side the plastic patch is on
- Note: The plastic patch will either be on the outboard or inboard side.



Use your hand to feel for the plastic patch as it may be hard to see on certain seat colors

PASSENGER SEAT INSPECTION

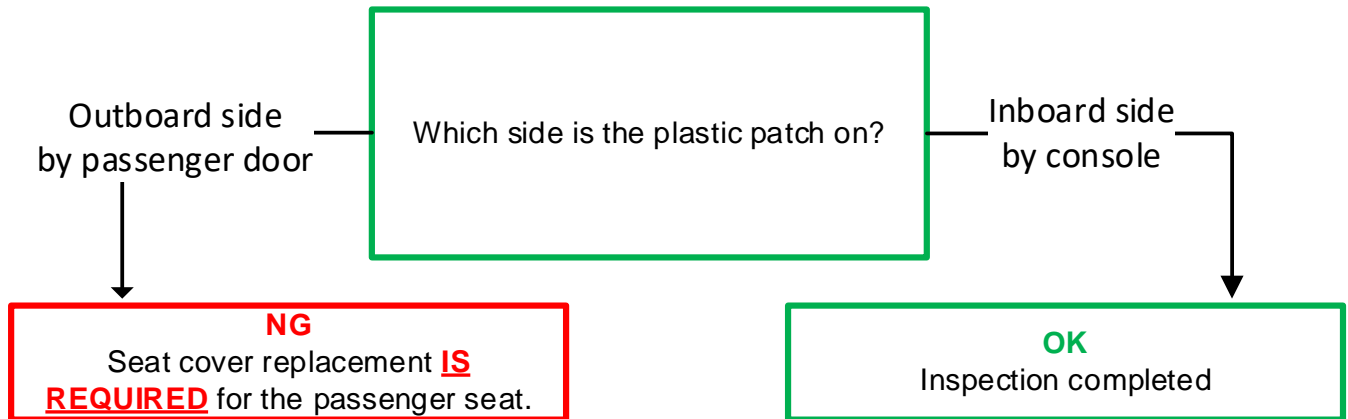

3. ORDER NECESSARY PARTS

- For any seat cover found to need replacement, order the part and install according to the next section

NOTE: It is expected that very few seats will require replacement. Double-Check your inspection results to ensure they are correct.

VII. REMOVAL

NOTE: This same procedure can be used for either the Driver or Passenger seat

1. REMOVE THE FRONT SEAT

a. Click the link below to access TIS for instructions on how to remove the front seat assembly

Power Seats

[SEAT: FRONT SEAT ASSEMBLY \(for Power Seat\): REMOVAL: 2020 - 2021 MY Highlander Highlander HV](#)
(Doc ID: RM100000001LKSO)

Manual Seats

[SEAT: FRONT SEAT ASSEMBLY \(for Manual Seat\): REMOVAL: 2020 - 2021 MY Highlander Highlander HV](#)
(Doc ID: RM100000001LKRU)

NOTE: Prior to removal, move the seat to the following position:

- Move the seat to the lowest position
- Move the seat to the middle position on the seat frame
- Fully recline the seatback to the furthest back position

When removing the wire harness from the seat frame take extra care when disengaging the clips as they are very fragile.

If broken reach out to Quality_Compliance@toyota.com for a replacement

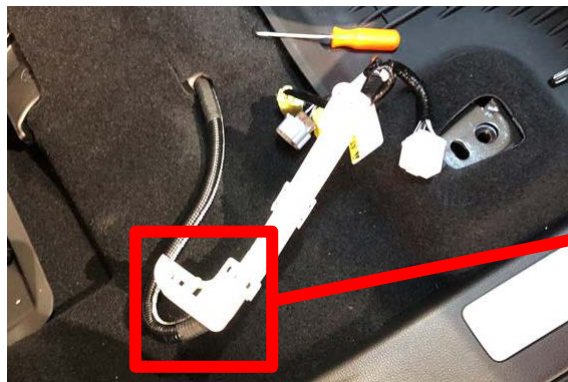

VIII. DISASSEMBLY

NOTE: This same procedure can be used for either the Driver or Passenger seat

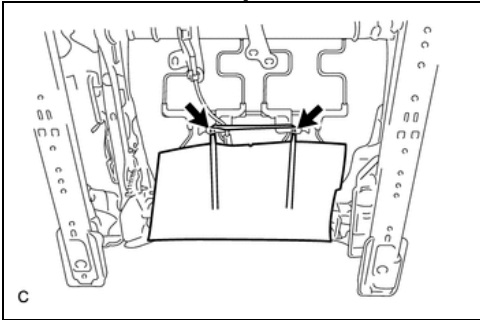

1. REMOVE SEATBACK COVER

a. Undo the elastic band from underneath the seat

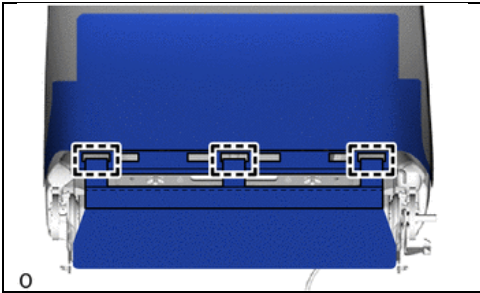

b. Unclip the 3 lower skirt clips from the upper skirt

c. Unzip both sides of the seatback cover



d. Disconnect the seat heater connection (if equipped)



e. Unclip the seat heater wire harness from the seat frame (if equipped)



f. Pinch and hold the foam in place



g. Grab the seatback cover from the seat base and pull the seatback cover to the front of the seat



h. Push the lower skirt clips through the seatback and cushion as you pull the lower skirt out. The final outcome should look like the picture to the left



i. Feed the seat heater wire harness through the middle of the seatback and cushion (If equipped)



Use your hand to prevent the clips from damaging the seat cover when feeding it through the middle of the seatback and cushion



j. Lift back of seatback cover up to reach the headrest posts.



k. Push the tabs in to remove the headrest posts

NOTE: The head rest posts are specific to side and position. Keep record of location of headrest post when removing



l. Fold seatback cover to the front of the seat by sliding your hand up the side of the seat cushion

STOP Do not try to completely remove the seat cover as it is still attached by clips on the front side

m. Using a screwdriver, disengage the 9 claws and remove the seat cover from the seat cushion

NOTE: Watch the video at the bottom of this page to see how to disengage the claws

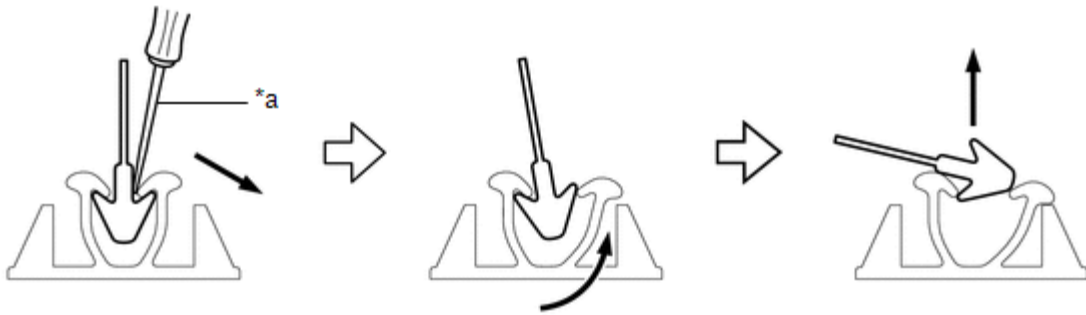
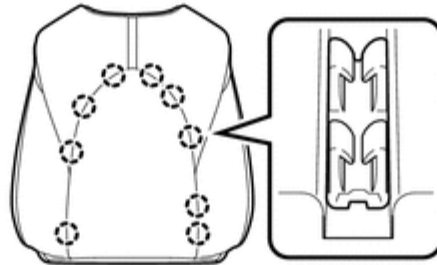

c

Click below to watch the video



IX. REASSEMBLY

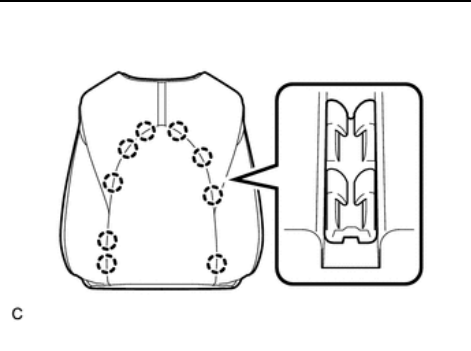

1. INSTALL THE NEW SEATBACK COVER

- Confirm the new seat cover is for the correct seat by looking at the last 2 characters on the tag.

LH = Driver's Seat

RH = Passenger Seat



The seat covers are symmetrical in shape and can go on the wrong seat, ensure it is correct.

- Align and center seatback cover to seatback cushion
- Using both thumbs, engage the 9 claws to install the seatback cover to the seatback cushion.

- Fold the seatback cover over the seatback cushion.



Use your hands to compress the sides of the cushion when folding the seat cover on to the cushion. This will prevent tears from happening in the seatback cover

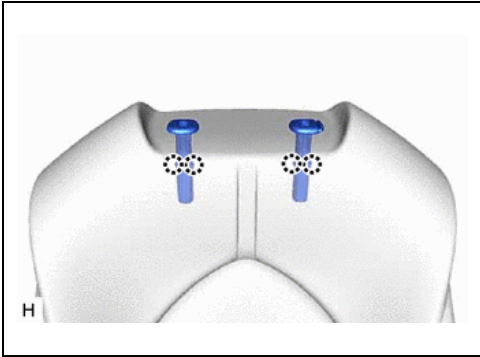

e. Install headrest posts into the proper slot

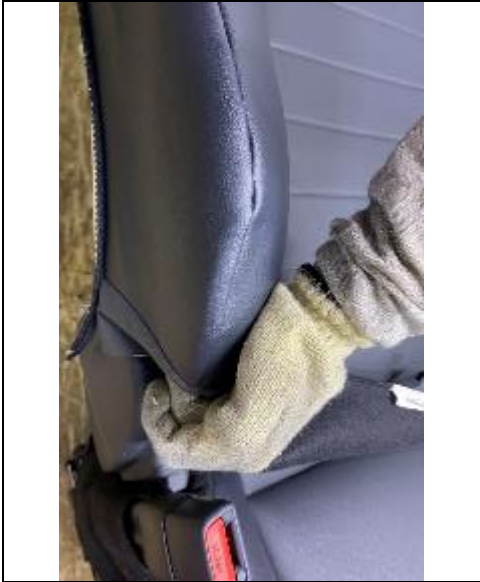

f. Fold the rest of the seatback cover over the seatback cushion. Keep tension on the seatback cover to prevent wrinkles

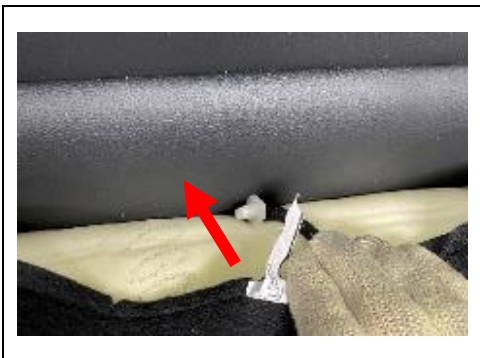

g. Feed the seat heater wire harness through the middle of the seatback and cushion

STOP Use your hand to prevent the clips from damaging the seat cover when feeding it through the middle of the seatback and cushion

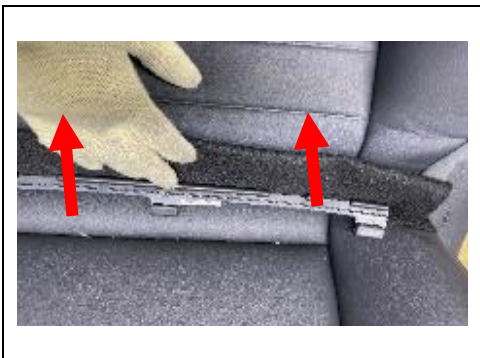

h. Feed the lower skirt through the middle of the seatback and cushion



- i. Pull the lower skirt tight to remove any wrinkles in the lower portion of the seatback cover



- j. Attach seat heater wire harness clips to the seat frame (if equipped)



- k. Connect the seat heater wire harness to the connector underneath the seat (if equipped)

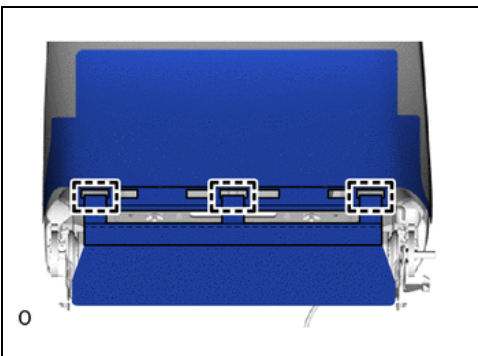

- l. Attached the lower skirt to the upper skirt using the 3 j-clips

NOTE: The seat heater wire should be on the inside of the skirt clips



m. Zip the seatback cover closed on each side

NOTE: You will need to adjust the seatback cover to the seat cushion to remove all wrinkles. If wrinkles are found, it will be necessary to adjust the seat cover until no wrinkles are found.

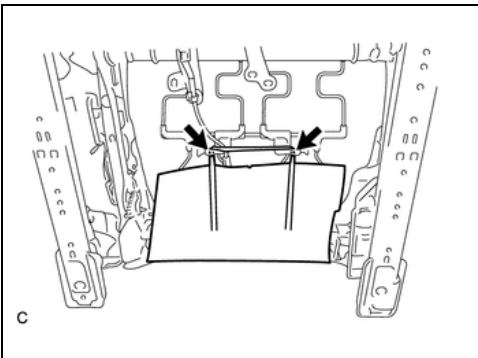

n. Attach the diaper elastic bands to the hooks.

o. Review the installation of the entire seatback cover to ensure there are no wrinkles or missed steps.

NOTE: Pay special attention on the corners along the side of the seatback, and the lower portion of the seatback when checking for fitment and wrinkles

X. INSTALLATION

1. TECHNICAL INSTRUCTIONS

- Click the link below to access TIS for instructions on how to install the Front Seat Assembly
- Perform all initializations required in the links below

Power Seats

[SEAT: FRONT SEAT ASSEMBLY \(for Power Seat\): INSTALLATION; 2020 - 2021 MY Highlander Highlander HV](#)
(Doc ID: RM100000001LKRY)

Manual Seats

[SEAT: FRONT SEAT ASSEMBLY \(for Manual Seat\): INSTALLATION; 2020 - 2021 MY Highlander Highlander HV](#)
(Doc ID: RM100000001LKRR)

◀ VERIFY REPAIR QUALITY ▶

- Confirm the inspection has been performed on both the front driver and passenger seat
- Confirm correct seat cover was installed on seat in case of both seats requiring repair
- Confirm no wrinkles are present
- Confirm seat heater operation (if equipped)
- Confirm all initializations were performed (as necessary)
- Confirm seat operation in all directions and check for noise or binding that may occur with improper installation.

If you have any questions regarding this update, please contact your regional representative.

XI. APPENDIX

A. PARTS DISPOSAL

In accordance with Federal law, please make sure all recalled parts (original parts) removed from the vehicle are disposed of in a manner in which they will not be reused, ***unless requested for parts recovery return.***

B. CAMPAIGN DESIGNATION DECORDER

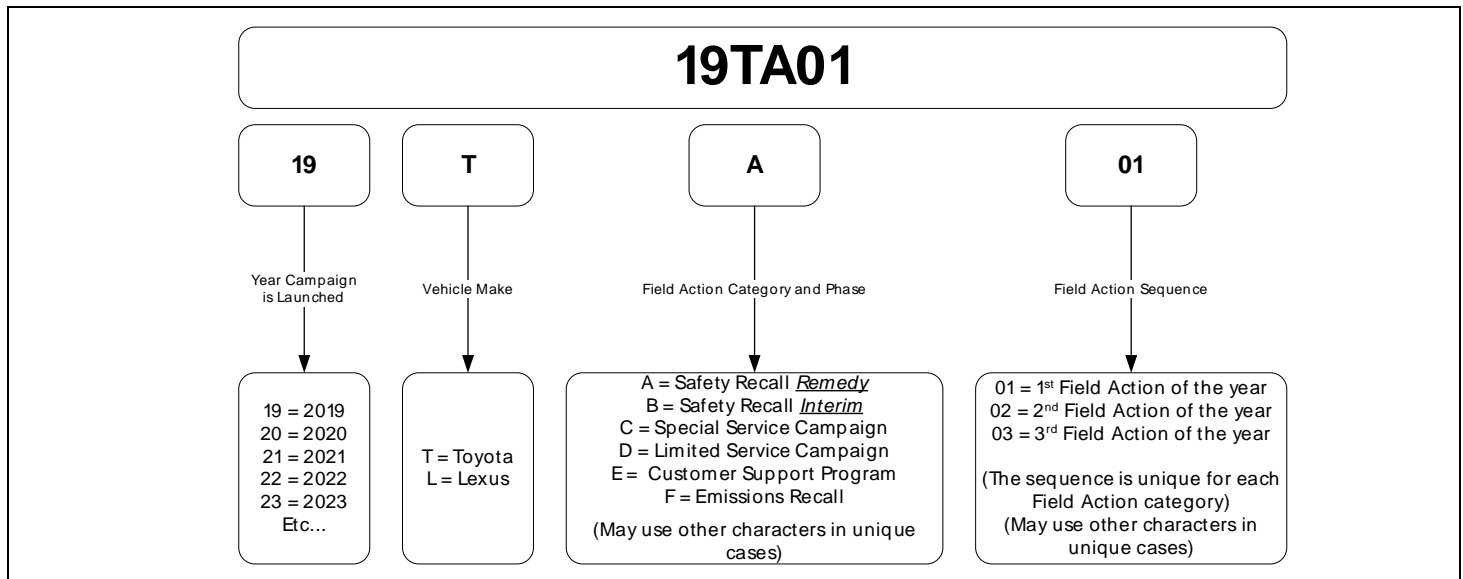

Examples:

19TA01 = Launched in 2019, Toyota, Safety Recall Remedy Phase, 1st Safety Recall Launched in 2019
20TC02 = Launched in 2020, Special Service Campaign, 2nd Special Service Campaign Launched in 2020
21TE05 = Launched in 2021, Customer Support Program, 5th Customer Support Program Launched in 2021