

<b>REFERENCE:</b>	Nova Bus Manuals
<b>SECTION:</b>	09: Engine and Cooling
<b>RS N°:</b>	MQR 7621-2169
<b>EFFECTIVE IN PROD.:</b>	N/A
<b>TC RECALL N°:</b>	2021-568
<b>NHTSA RECALL N°:</b>	20V568

**APPLICATION DEADLINE:** NA  
**CLAIM REFERENCE NUMBER:** SR-5138

<b>SUBJECT:</b>	Power Steering
<b>JUSTIFICATION:</b>	Certain power steering pipes may separate at the connection joint. This may cause a power steering assist lost and power steering fluid spillage from the ceiling in the cabin.

LEVEL	DESCRIPTION	DIRECT CHARGES		TIME
		LABOUR	MATERIAL	
1	Replace hydraulic pipe N77549-01.	Nova Bus	Nova Bus	12 h
2	–	–	–	–

**Matériel list on page 2**

**DISPOSAL OF PARTS**

<b>REMOVED PARTS ARE:</b>	<b>DISCARDED</b> *	<b>RETAINED</b>	* Dispose of the unused parts and the defective parts in accordance with local environmental standards in effect.
	Yes	–	

**REVISION HISTORY**

REV.	DATE	CHANGE DESCRIPTION	WRITTEN BY
NR	2021OC22	Initial release	Annie St-Jacques
R1	2022FE18	- Shop supply added in material list. - Steps 1.40.f and 1.42.g added.	Annie St-Jacques

**APPROVED BY:**

**PAGE 1 OF 13**

**MATERIAL**

QTY	PART N°	REV.	DESCRIPTION	REPLACES PART N°
<b>LEVEL 1</b>				
5	G5007994	-	CABLE TIE	-
18	G5007995	-	CABLE TIE (PRV# 504637)	-
13	G5007996	-	CABLE TIE	-
6	N0224003	A	LOCK NUT NYLON 3/8F ZP	-
2	N26360	C	TUBE INSULATION 5/8" (6 FT)	-
26	N73848	E	SCREW #10-16 X 1 3/8" TORX SS	-
1	N77549-01	-	PIPE SUPPLY ASSY STEEL	-
1	N85710-13	-	INSULATION DUCT	-
4	N99199-01	-	BOLT T 3/8" SPEC RECT HD GRD5	-
2	N99199-02	-	BOLT T 3/8" SPEC RECT HD GRD5	-
<b>LEVEL 1 SHOP SUPPLY</b>				
3 Li	HYDRAULIC OIL		A MAXIMUM OF 3 LITERS OF HYDRAULIC OIL WILL BE REFUNDABLE UPON CLAIM.	-
1.5 me	N66955	-	TAPE ALUMINIUM FOIL* (roll of 55 meters)	-
65 ml	N35535-01	-	SIKAFLEX 552 AEROGRAY DARK/400* (1 sausage = 400 ml)	-
*SPECIFY THE QUANTITY REQUIRED ACCORDING TO YOUR NUMBER OF VEHICLE.				
<b>LEVEL 2</b>				
-	-	-	-	-

Materials will be available within 105 days once your order has been placed. To order, please contact novabus.parts@volvo.com or by phone for CANADA 1-800-771-6682, for USA 1-877-999-8808. Specify document number, quantity of parts required and shipping address.

CLIENT	ORDER	ROAD NUMBER		VIN (2NVY/4RKY...)		QTY
		FROM	TO	FROM	TO	
San Juan Puerto Rico	LD01	2020-01	2020-01	L82J0L97775	L82J0L97775	1
San Juan Puerto Rico	LD32	2021-01	2021-10	L82J5L97777	L82J6L97777	10

**WARNING**

---

FOLLOW YOUR INTERNAL SAFETY PROCEDURES.

## PROCEDURE

**NOTE**

---

Your configuration may differ.

**NOTE**

---

Unless otherwise specified retain the hardware removed during the procedure for later reinstallation.

## PREPARE VEHICLE

- 1.1. Park the vehicle on a level surface with the transmission on neutral.
- 1.2. Apply the parking brake and set the master control switch to the **stop** position.
- 1.3. Set the battery disconnect switch in the battery compartment to the **off** position and lock out the switch.

## DRAIN HYDRAULIC OIL

**NOTE**

---

Refer to the maintenance manual, section *09: Engine and Cooling*, for **HYDRAULIC OIL DRAIN PROCEDURE**.

- 1.4. Open the rear engine access door. Locate the hydraulic reservoir and place a clean container to recover the oil (Figure 1).
- 1.5. Drain the oil. Keep the oil, it will be reused to fill the reservoir after the work has been completed.
- 1.6. Open the right front access door, locate the drain plug on the 90 deg fitting and place a clean container under it (Figure 2).
- 1.7. Remove plug and drain the remaining oil from the pipe. Keep the oil, it will be reused to fill the reservoir after the work has been completed.



Figure 1 - Place Container to Collect Hydraulic Oil

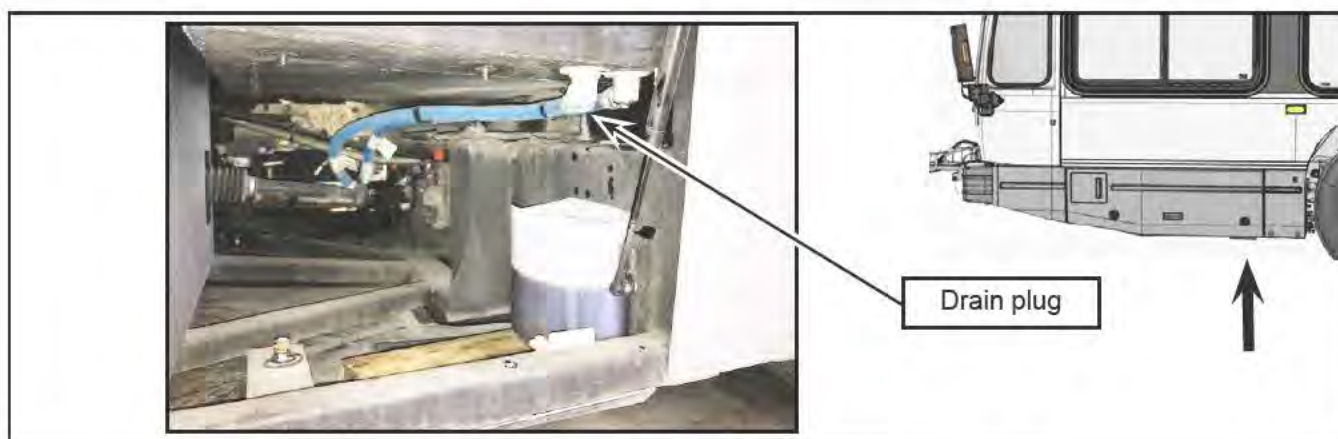

Figure 2 - Place Container to Collect Remaining Hydraulic Oil

## HYDRAULIC PIPE N77549-01

### GET ACCESS

- 1.8. Inside the vehicle behind the driver's partition remove the longitudinal seat.
  - a. Mark the T-bolts position on the upper/wall rail with a marker or masking tape.
  - b. Disconnect any electrical connection underneath the seat.
  - c. Unscrew nuts.
  - d. Remove seat. If applicable, keep shims between the cantilever leg and the rail for later reinstallation.
  - e. Discard all T-bolts and nuts.



- 1.9. Next to the ceiling, to access the hydraulic pipe N77549-01 (Figure 3), remove:
  - a. Access panel.
  - b. Curtains.
  - c. The fluorescent light under the ITS box. If needed, loosen or remove the windows clamping.
- 1.10. Remove the chime (Figure 3).
  - a. Unscrew the 4 screws to remove the chime cover.
  - b. Disconnect the 2 rounds terminals.
  - c. Unscrew the 2 mounting screws and remove the chime (to not lose the spacers behind the chime, do not pull out the screws completely).
- 1.11. Remove the chime cord (Figure 3).
  - a. Unscrew the screws above and below and remove the cover.
  - b. Disconnect the 2 round terminals.
  - c. Unscrew the 2 mounting locknuts and remove the module and the cord.

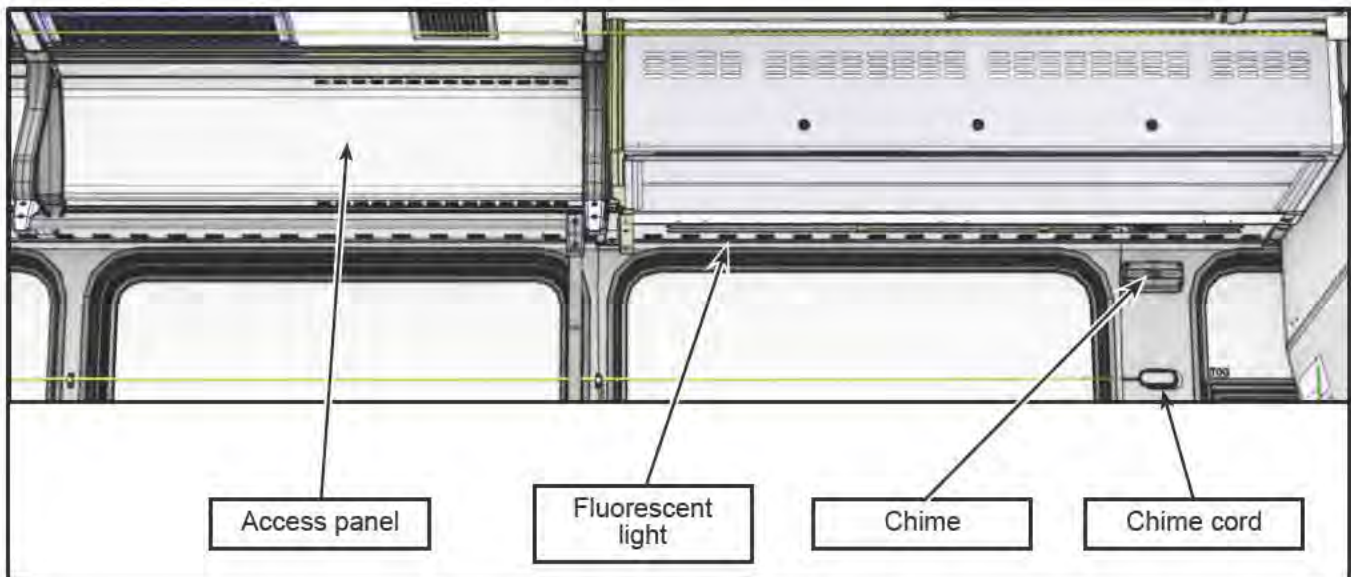

Figure 3 - Components to Remove (Typical)

- 1.12. Remove the upper/wall seat rail (Figure 4).
  - a. Cut sealant at each end.
  - b. Unscrew the 3 M10 bolts with a manual tool to avoid spinning the rivnuts.
  - c. Keep the rail, the 3 M10 bolts and the 3 rectangular retainers.
- 1.13. Remove the air duct plate (Figure 4).
- 1.14. Remove the lower/floor seat rail (Figure 4).
  - a. Cut sealant at each end.
  - b. Underneath the vehicle, unscrew the 3 nuts.
  - c. Keep the rail, the 3 bolts, the 3 square plates, the 3 washers and the 3 nuts.

- 1.15. Remove the melamine panels (Figure 4).
  - a. Remove the melamine panel between the windows. If needed, loosen or remove the windows clamping (the melamine panel is fragile, especially the corners).
  - b. Remove the trim and the lower melamine panel.
- 1.16. Open the ITS box and lower the shelf.

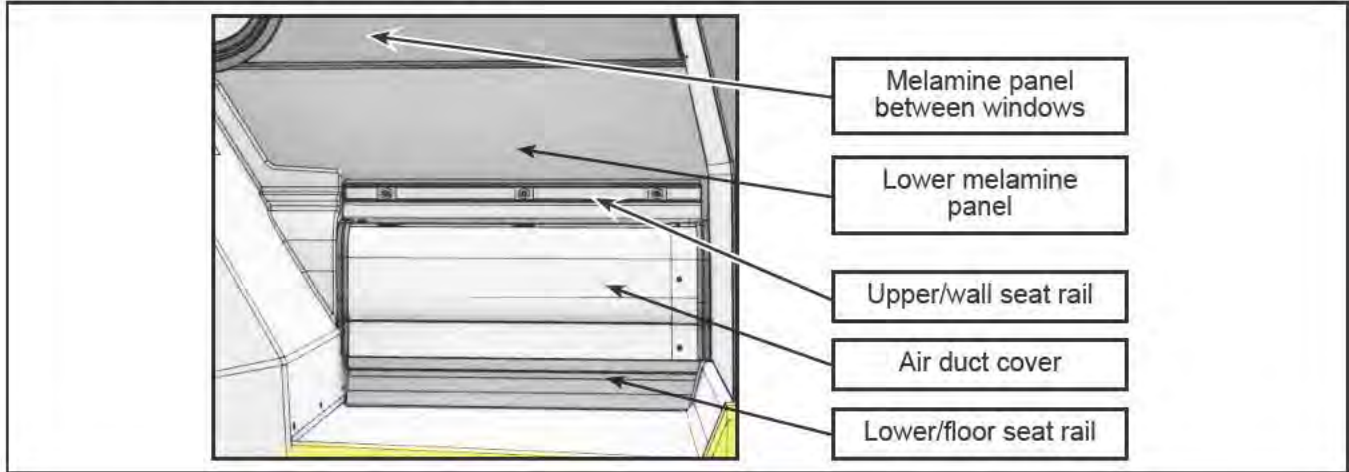

Figure 4 - Components to Remove (Typical)

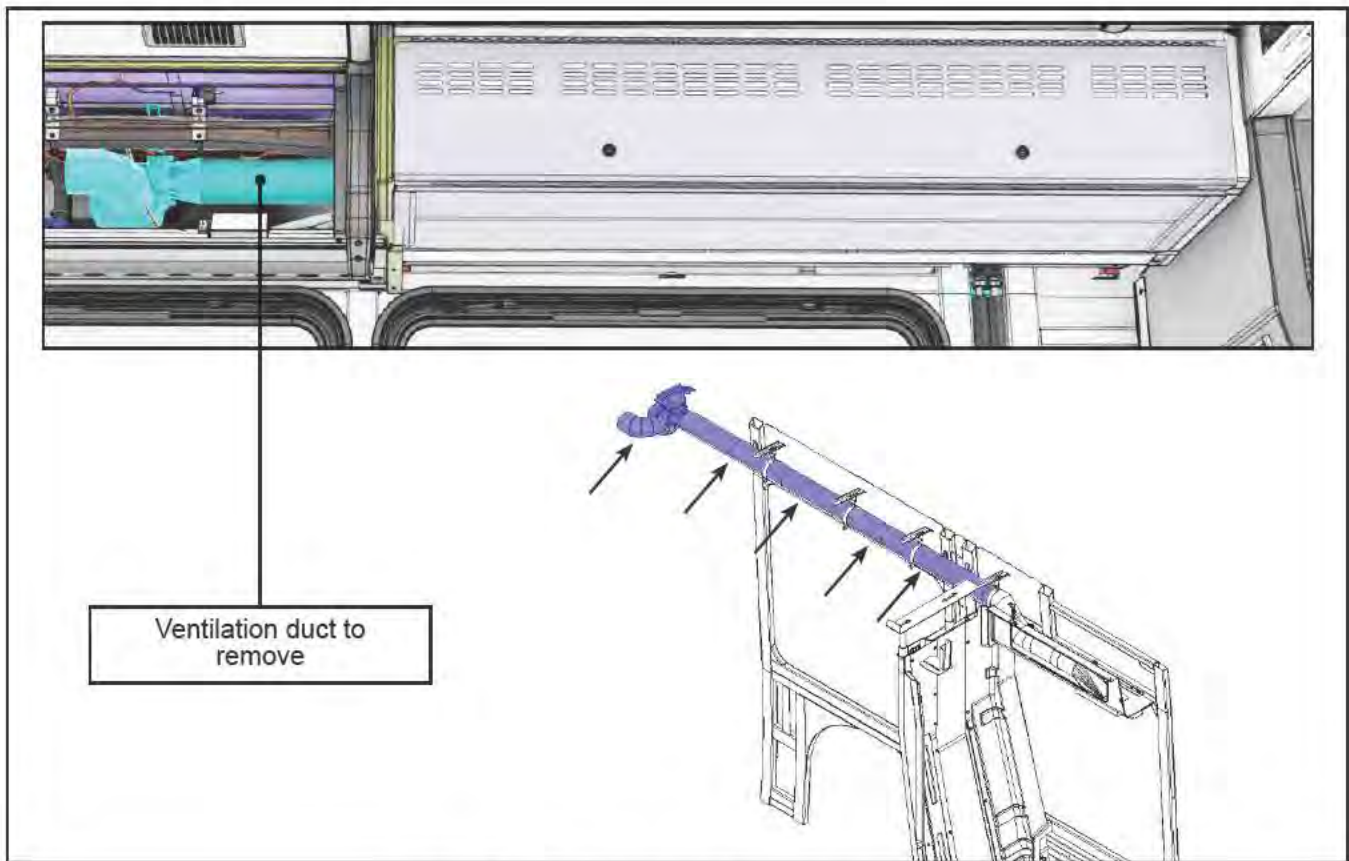

Figure 5 - Ventilation Duct to Remove (Typical)

- 1.17. Remove the ventilation duct (Figure 5).
  - a. Disconnect the electrical cable and unscrew the 4 screws to remove the blower (Figure 6). Keep the 4 screws and the 4 locknuts.

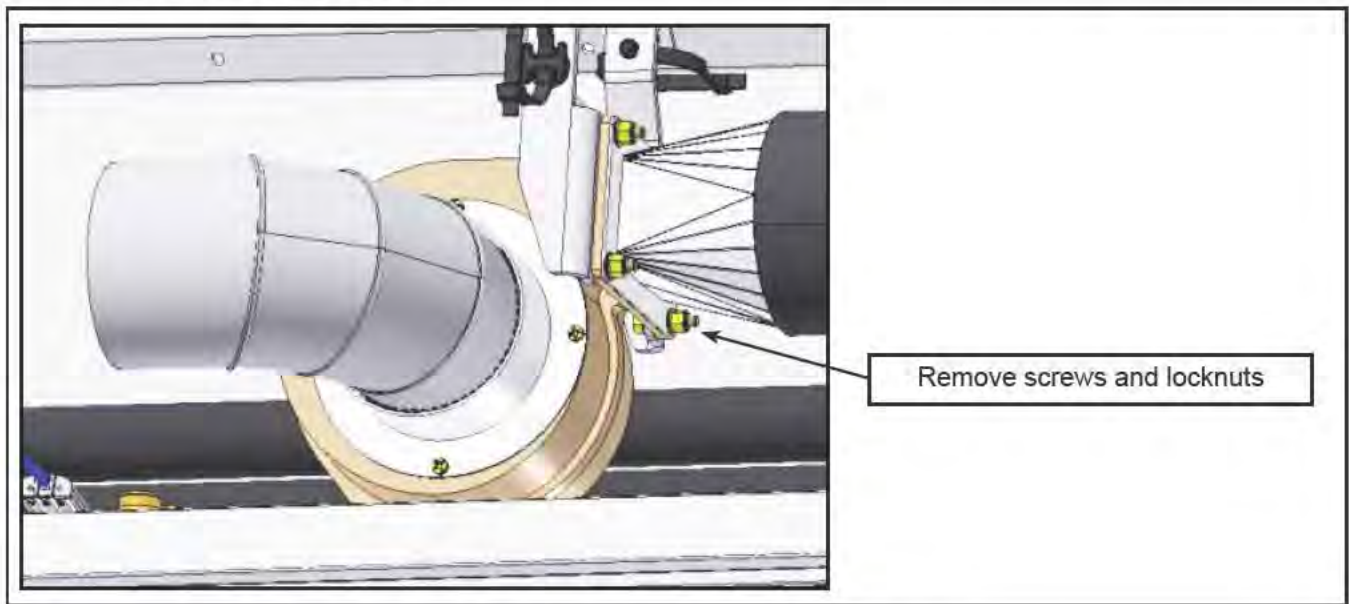

Figure 6 - Remove the Ventilation Blower (Typical)

- b. Open the 3 support clamps. Unscrew the screw, lift the removable section of the support clamp and remove (Figure 7). Keep all parts and hardware.

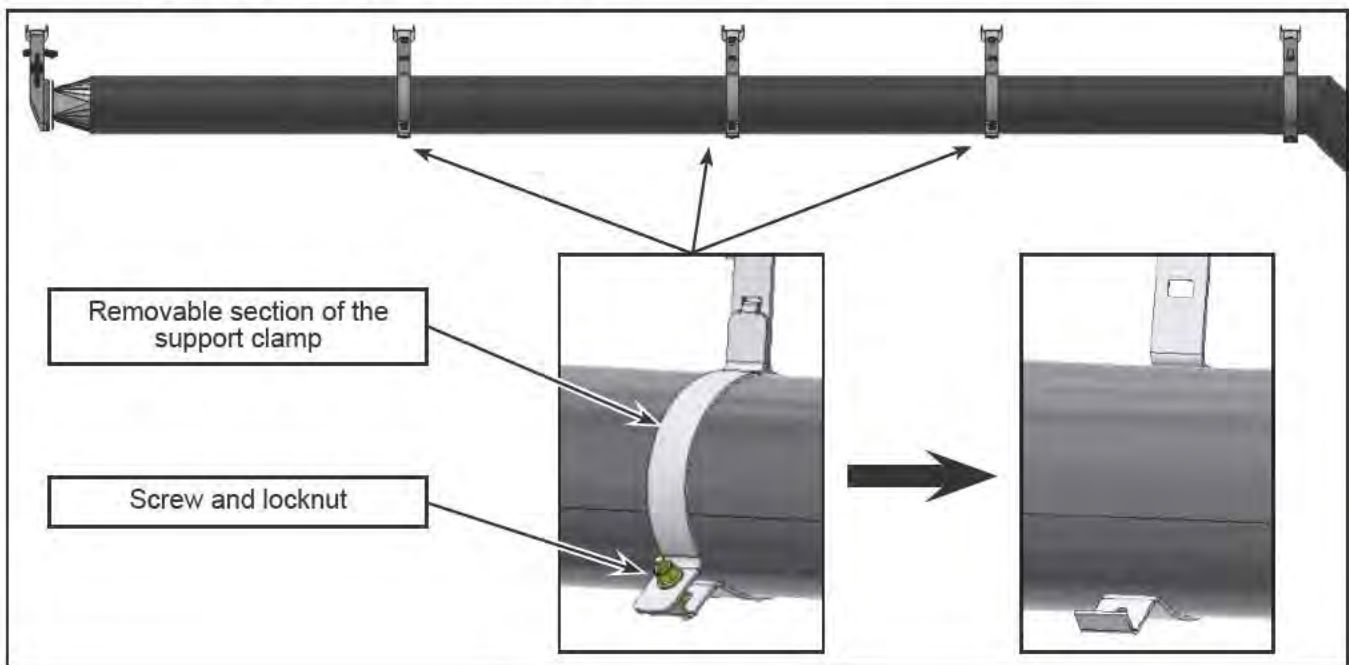

Figure 7 - Open the Support Clamps



- c. Remove the insulation and the aluminum foil tape over the duct joints (Figure 8). It might be difficult to find the joints under the insulation, rotate a section back and forth to see where the joint is, the insulation should deform or stretch over it.



Figure 8 - Remove the Insulation and the Aluminum Foil Tape

- d. Slide out and remove the 3 sections of duct one by one starting with the one on the blower side (Figure 9).

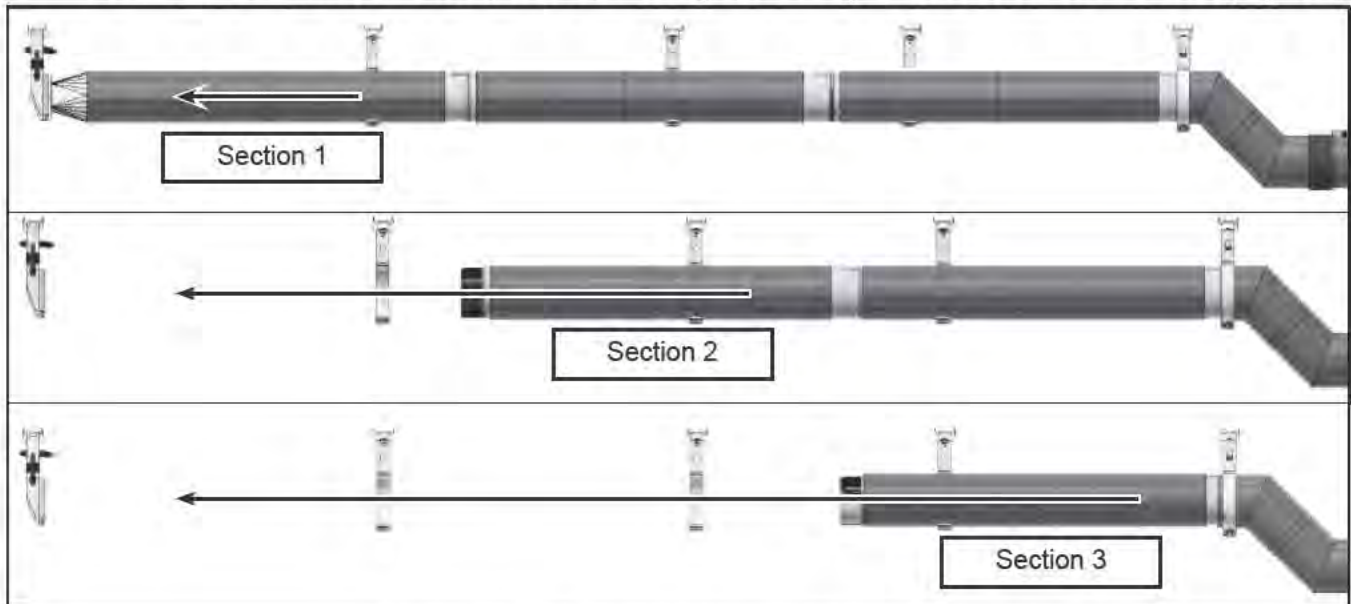

Figure 9 - Slide Out and Remove 3 Sections of Duct



- 1.18. To access the hydraulic pipe N77549-01 connection, cut cable ties securing the Pex Pipes to their support bracket to move them away (Figure 10).

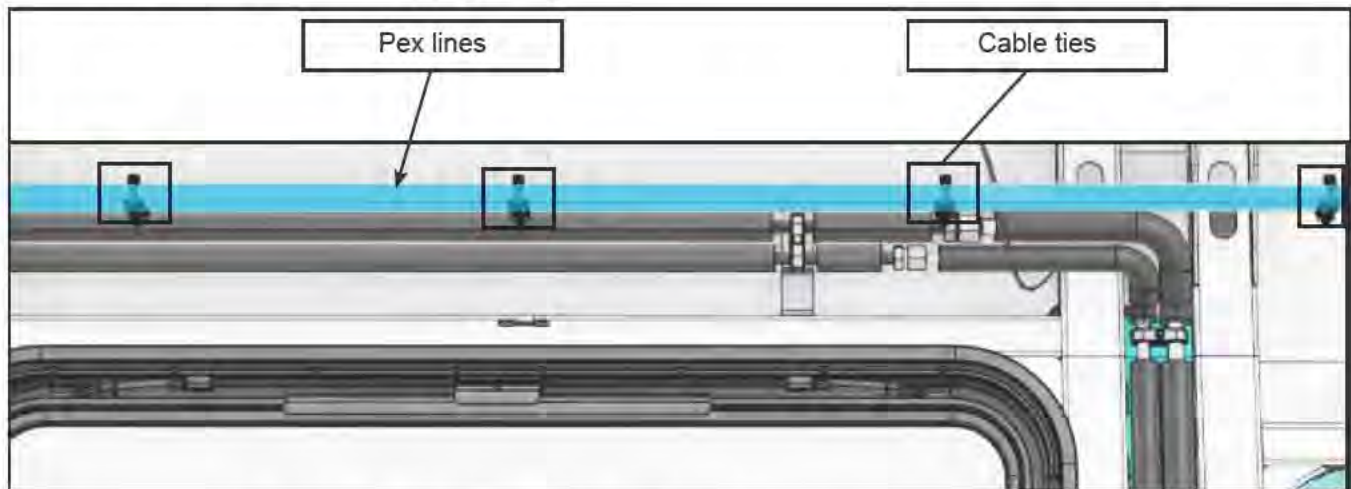

Figure 10 - Pex Lines - Cable Ties to Remove (Components Omitted for Clarity)

#### REMOVE HYDRAULIC PIPE N77549-01

- 1.19. Locate hydraulic pipe N77549-01 (Figure 11).
- 1.20. Remove the 2 support brackets.
- 1.21. In order to remove the hydraulic pipe N77549-01, it is necessary to first remove the return hydraulic pipe located next to it because of the presence of the chime cord mounting plate (Figure 11).
- Disconnect the ORS fitting at each end of both pipes (note: a small amount of oil will pour).
  - Remove the return pipe.
  - Remove the pipe N77549-01.

#### INSTALL NEW HYDRAULIC PIPE N77549-01

- 1.22. Install new insulation N26360 on the new hydraulic pipe N77549-01 as on the old one.
- 1.23. Install the pipe N77549-01 in the vehicle and hand tighten the ORS fittings.
- 1.24. Reinstall the return hydraulic pipe and hand tighten the ORS fittings.
- 1.25. Tighten the 4 ORS fittings to the torque value of 48 lb-ft (65 N·m).



#### NOTE

Refer to the maintenance manual, section 99: *General Practices*, for **ORS-TYPE FITTING INSTALLATION**.

- 1.26. Reinstall the 2 support brackets.
- 1.27. Discard the old hydraulic pipe N77549-01.

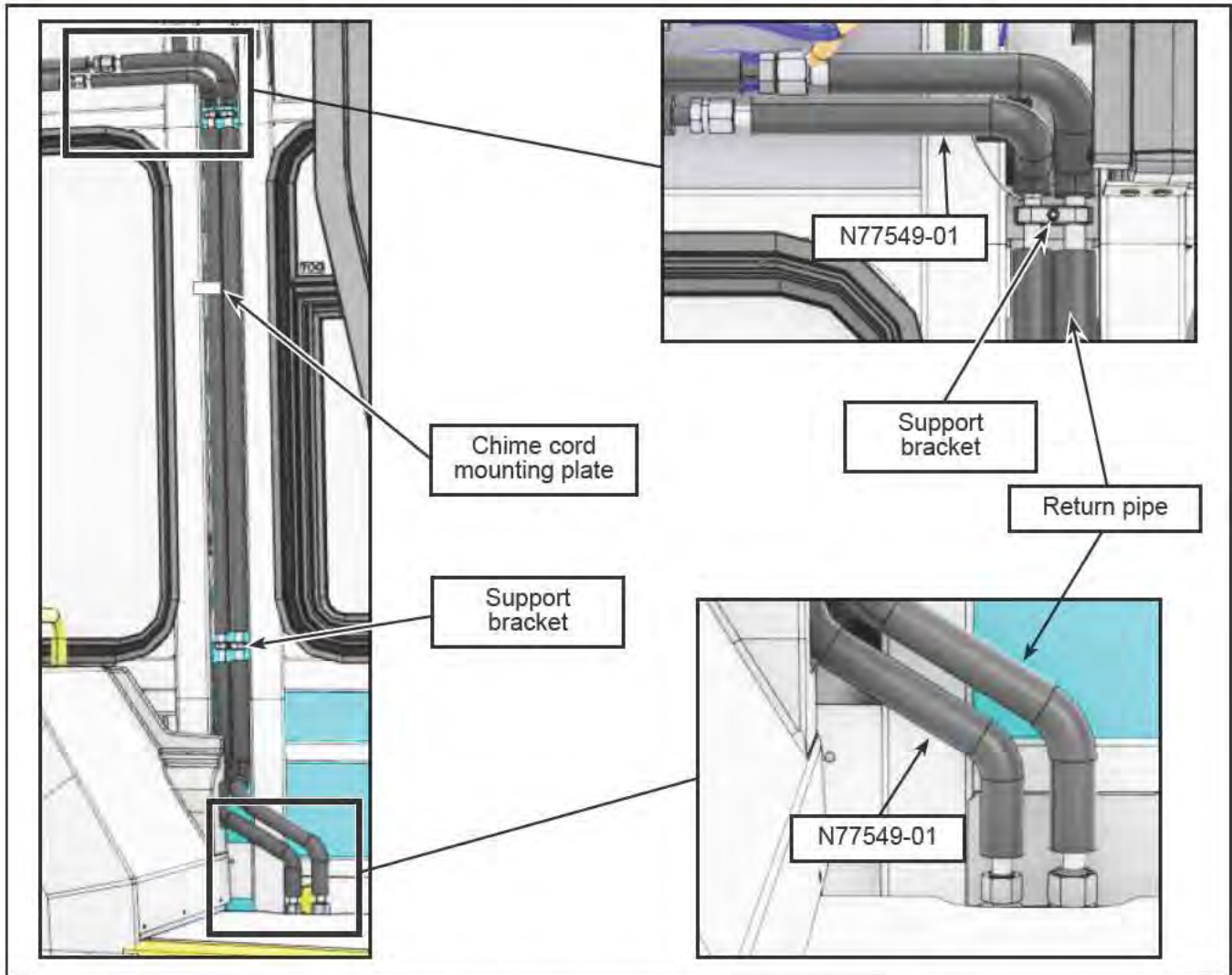

Figure 11 - Hydraulic Pipe N77549-01 (Components Omitted for Clarity)

## REFILL HYDRAULIC RESERVOIR



### NOTE

Refer to the maintenance manual, section 09: *Engine and Cooling*, for **HYDRAULIC OIL FILLING PROCEDURE**.

- 1.28. Fill the hydraulic oil reservoir to the required level.
- 1.29. Start the vehicle and turn the steering wheel back and forth.
- 1.30. Inspect pipe N77549-01 connections to ensure there are no leaks.
- 1.31. Stop the engine.



---

**CLEAN AND CLOSE****CLEAN**

- 1.32. Clean any excess oil.

**CLOSE ACCESS**

- 1.33. Reposition the Pex lines and secure with the cable ties G5007996 (ref. Figure 10).
- 1.34. Reinstall the ventilation duct.
- Slide back in the 3 sections of duct at their original position (ref. Figure 9).
  - Seal the 3 duct joints with the new aluminum foil tape N66955.
  - Install new insulation over the aluminum foil tape by cutting the required widths in the new insulation sheet N85710-13 to replace the pieces removed at step 1.17.c (ref. Figure 8).
  - Reinstall the blower on its support bracket with the 4 M6x25 screws and the 4 locknuts (ref. Figure 6).
  - Close the 3 support clamps with the removed support clamp section and secure with the M6x30 screw and the locknut (ref. Figure 7).
  - Reconnect the blower electrical cable.
- 1.35. Reinstall the melamine panels and the between trim (don't forget to pass thru any electrical cables).
- 1.36. Reinstall the chime cord.
- Pass the electrical cable thru the pass hole.
  - Insert the module onto the mounting screw and tighten with the M5 locknut.
  - Reconnect the 2 round terminals, the white wire to the top contact and the black wire to the bottom contact.
  - Reinstall the cover with its 2 screws.
- 1.37. Reinstall the chime.
- Pass the electrical cable thru the pass hole.
  - Apply new thread locker, Loctite 242 (Nova Bus #9985283) or equivalent, on the two M5 x 25 mm screws. Reinstall chime on the wall with the two 1/2 in. spacers.
  - Reconnect the 2 terminals to the terminal strip.
  - Reinstall cover with the 4 screws.
- 1.38. Reinstall the first fluorescent light, the curtains and the access panel.
- 1.39. If the windows clamping was loosened or removed, reinstall with new screws N73848. Torque the screws.

**NOTE**

---

**Refer to the maintenance manual, section 03: Windows, Windshield and Accessories, for the TORQUE SEQUENCE AND VALUE.**

- 1.40. Reinstall the floor rail in the same position with the removed hardware: 3 M10 mushroom square bolts, 3 square plates, 3 M10 oversize washers and 3 M10 nuts.
- Clean the 3 bolts to remove any old anti-seize compound and dirt.
  - Reinsert the 3 bolts and the 3 square plates into the rail.
  - Put the rail in place inserting the bolts into the floor. Position the rail like before.
  - Underneath the vehicle, apply new anti-seize compound, NeverSeez (Nova Bus #R085023) or equivalent, on bolts and install the 3 washers and the 3 nuts.

- e. Torque the nuts to the torque value show in Figure 12 and apply torque seal on nuts.
- f. Apply sealant Sikaflex 552 N35535-01 to both ends of the rail to fill in the gaps.

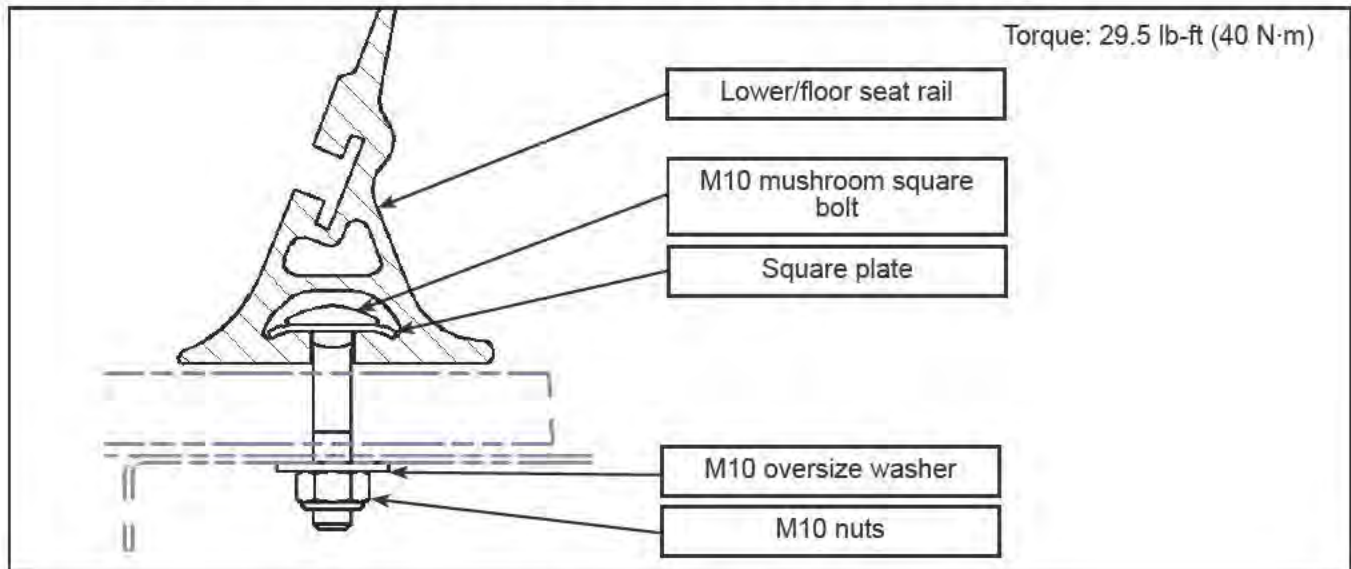

Figure 12 - Lower/Floor Seat Rail

- 1.41. Reinstall the air duct plate.
- 1.42. Reinstall the upper/wall rail with the removed hardware: 3 M10 screws and 3 rectangular retainers.
  - a. Clean the screws and the rivnuts to remove the old thread locker.
  - b. Apply new thread locker, Loctite 242 (Nova Bus #9985283) or equivalent, on screws.
  - c. Install the rail with the 3 rectangular retainers and the 3 screws. Hand tighten.
  - d. From the rear to the front, make a first tightening to the torque value shown in Figure 13.
  - e. Again from the rear to the front make a second tightening to the same torque value.
  - f. Apply torque seal on bolts.
  - g. Apply sealant Sikaflex 552 N35535-01 to both ends of the rail to fill in the gaps.

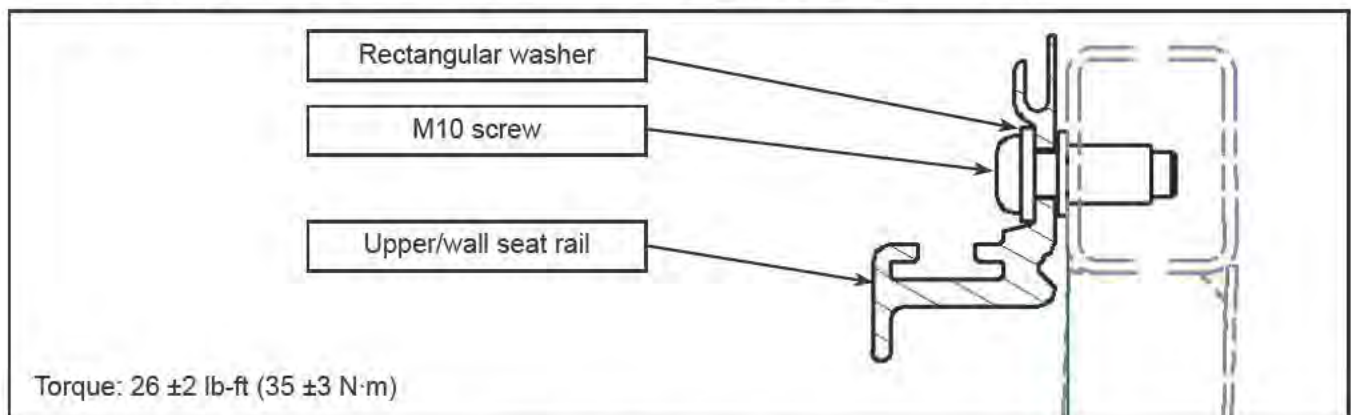

Figure 13 - Upper/Wall Seat Rail



- 1.43. Reinstall the longitudinal seat.
- Install 4 new T-Bolts N99199-01 into the upper/wall rail and install 2 new T-bolts N99199-02 into the floor rail.
  - Position the T-bolts on the marks made previously and install seat. If applicable, reinstall any shim between the seat floor rail and the seat cantilever leg.
  - Secure seat with 6 new flange serrated nuts N0224003 and hand tighten.
  - Validate that the T-bolts are locked in the rail with their notches aligned towards the center of the vehicle (Figure 14).



Figure 14 - The Notch of the T-Bolt Aligned Towards the Center of the Vehicle

- Torque the nuts to the torque value shown in Figure 15.
- Apply torque seal on nuts.
- If applicable, reconnect any electrical connection and secure with cable ties.

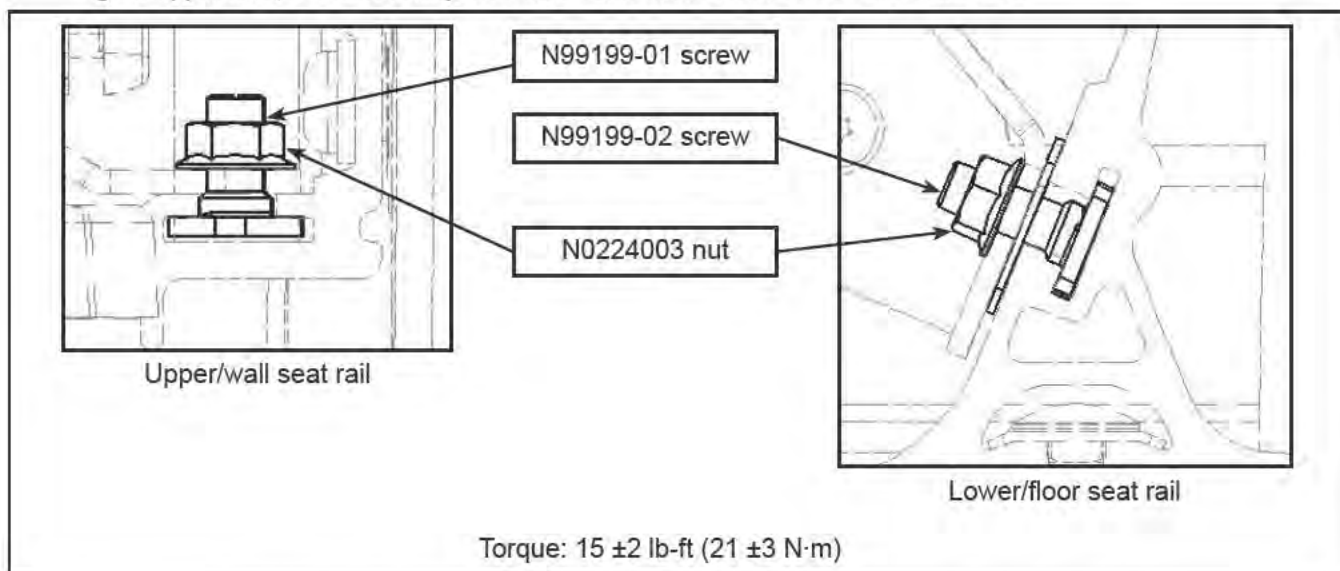

Figure 15 - Seats Fasteners and Torque on Upper/Wall and Lower/Floor Seat Rail

- 1.44. The vehicle can return in service. ❖