

REFERENCE:	Nova Bus Manuals
SECTION:	09: Engine and Cooling
RS N°:	MQR 7621-2169
EFFECTIVE IN PROD.:	N/A
TC RECALL N°:	2021-568
NHTSA RECALL N°:	20V568

APPLICATION DEADLINE: NA
CLAIM REFERENCE NUMBER: SR-5107

SUBJECT:	Power Steering
JUSTIFICATION:	Certain power steering pipes may separate at the connection joint. This may cause a power steering assist lost and power steering fluid spillage from the ceiling in the cabin.

LEVEL	DESCRIPTION	DIRECT CHARGES		TIME
		LABOUR	MATERIAL	
1	Replace hydraulic pipe N77549-01.	Nova Bus	Nova Bus	12 h
2	–	–	–	–

Matériel list on page 2

DISPOSAL OF PARTS

REMOVED PARTS ARE:	DISCARDED *	RETAINED	* Dispose of the unused parts and the defective parts in accordance with local environmental standards in effect.
	Yes	–	

REVISION HISTORY

REV.	DATE	CHANGE DESCRIPTION	WRITTEN BY
NR	2021OC22	Initial release	Annie St-Jacques
R1	2022FE18	- Shop supply added in material list. - Steps 1.37.f and 1.39.g added.	Annie St-Jacques

APPROVED BY:

MATERIAL

QTY	PART N°	REV.	DESCRIPTION	REPLACES PART N°
LEVEL 1				
5	G5007994	-	CABLE TIE	-
18	G5007995	-	CABLE TIE (PRV# 504637)	-
13	G5007996	-	CABLE TIE	-
2	N26360	C	TUBE INSULATION 5/8" (6 FT)	-
26	N73848	E	SCREW #10-16 X 1 3/8" TORX SS	-
1	N77549-01	-	PIPE SUPPLY ASSY STEEL	-
1	N85710-13	-	INSULATION DUCT	-
LEVEL 1 SHOP SUPPLY				
3 Li	HYDRAULIC OIL		A MAXIMUM OF 3 LITERS OF HYDRAULIC OIL WILL BE REFUNDABLE UPON CLAIM.	-
1.5 me	N66955	-	TAPE ALUMINIUM FOIL* (roll of 55 meters)	-
65 ml	N35535-01		SIKAFLEX 552 AEROGRAY DARK/400* (1 sausage = 400 ml)	-
*SPECIFY THE QUANTITY REQUIRED ACCORDING TO YOUR NUMBER OF VEHICLE.				
LEVEL 2				
-	-	-	-	-

Materials will be available within 105 days once your order has been placed. To order, please contact novabus.parts@volvo.com or by phone for CANADA 1-800-771-6682, for USA 1-877-999-8808. Specify document number, quantity of parts required and shipping address.

CLIENT	ORDER	ROAD NUMBER		VIN (2NVY/4RKY...)		QTY
		FROM	TO	FROM	TO	
Capital Area Transportation Authority Michigan - CATA	LC75	-	-	S92J4K97774	S92J4K97774	1
Capital Area Transportation Authority Michigan - CATA	LD34	719	730	L82J8L97777	L82J2L97777	12
Capital Area Transportation Authority Michigan - CATA	LD35	6016	6018	S92J3L97777	S92J7L97777	3

**WARNING**

FOLLOW YOUR INTERNAL SAFETY PROCEDURES.

PROCEDURE

**NOTE**

Your configuration may differ.

**NOTE**

Unless otherwise specified retain the hardware removed during the procedure for later reinstallation.

PREPARE VEHICLE

- 1.1. Park the vehicle on a level surface with the transmission on neutral.
- 1.2. Apply the parking brake and set the master control switch to the **stop** position.
- 1.3. Set the battery disconnect switch in the battery compartment to the **off** position and lock out the switch.

DRAIN HYDRAULIC OIL

**NOTE**

Refer to the maintenance manual, section *09: Engine and Cooling*, for **HYDRAULIC OIL DRAIN PROCEDURE**.

- 1.4. Open the rear engine access door. Locate the hydraulic reservoir and place a clean container to recover the oil (Figure 1).
- 1.5. Drain the oil. Keep the oil, it will be reused to fill the reservoir after the work has been completed.
- 1.6. Open the right front access door, locate the drain plug on the 90 deg fitting and place a clean container under it (Figure 2).
- 1.7. Remove plug and drain the remaining oil from the pipe. Keep the oil, it will be reused to fill the reservoir after the work has been completed.



Figure 1 - Place Container to Collect Hydraulic Oil

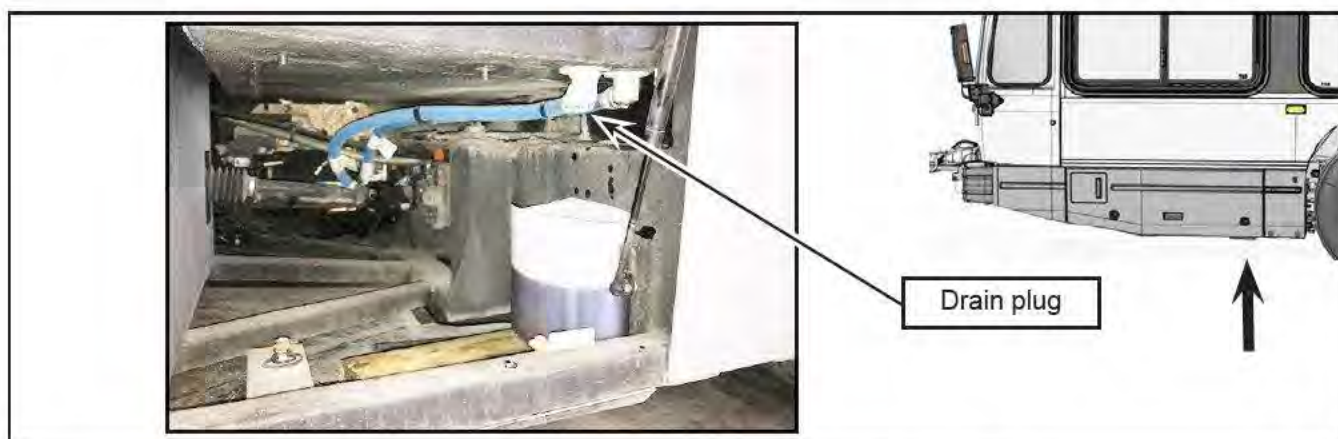

Figure 2 - Place Container to Collect Remaining Hydraulic Oil

HYDRAULIC PIPE N77549-01

GET ACCESS

- 1.8. Inside the vehicle behind the driver's partition remove the transversal seat on the wheelhouse.
 - a. Disconnect any electrical connection underneath the seat.
 - b. Unscrew the 8 screws and remove the seat. Be careful that the spacers between the fibreglass wheelhouse and the stainless wheelhouse do not fall in between. **Note their positions for reinstallation.**
 - c. Keep the 8 screws, the 8 lock washers, the 8 washers and the spacers (quantity and spacer height depend of your vehicle).

- 1.9. Next to the ceiling, to access the hydraulic pipe N77549-01 (Figure 3), remove:
 - a. Access panel.
 - b. Curtains, if applicable.
 - c. The fluorescent light under the ITS box. If needed, loosen or remove the windows clamping.
- 1.10. Remove the chime (Figure 3).
 - a. Unscrew the 4 screws to remove the chime cover.
 - b. Disconnect the 2 rounds terminals.
 - c. Unscrew the 2 mounting screws and remove the chime (to not lose the spacers behind the chime, do not pull out the screws completely).

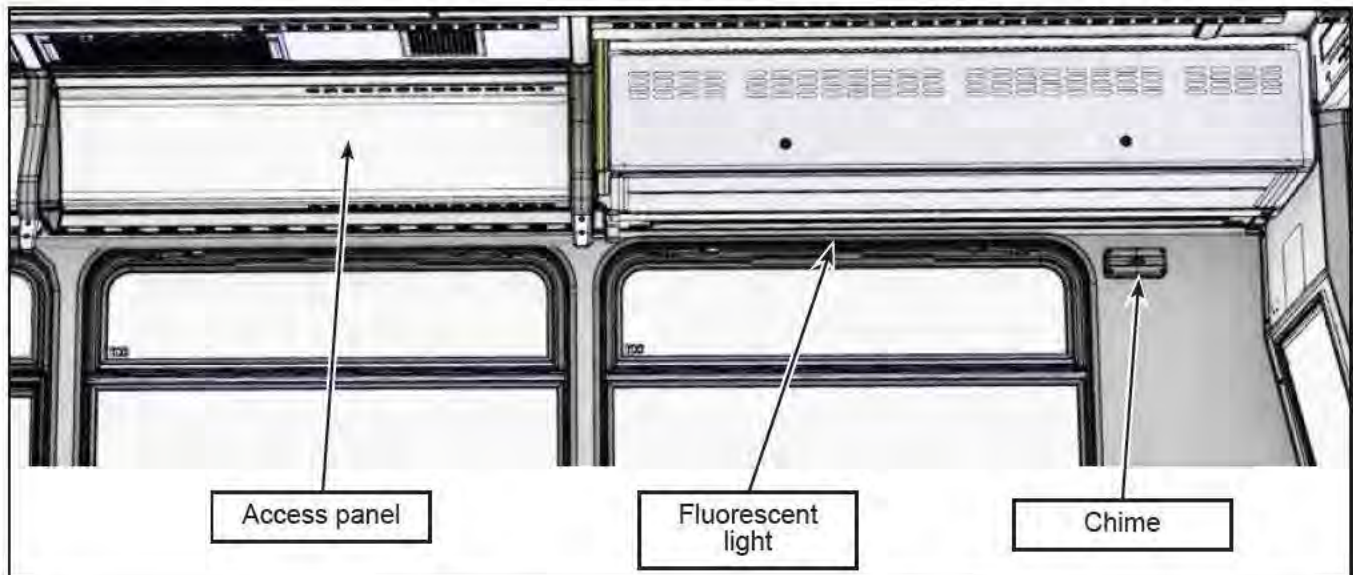

Figure 3 - Components to Remove (Typical)

- 1.11. Remove the upper/wall seat rail (Figure 4).
 - a. Cut sealant at each end.
 - b. Unscrew the 3 M10 bolts with a manual tool to avoid spinning the rivnuts.
 - c. Keep the rail, the 3 M10 bolts and the 3 rectangular retainers.
- 1.12. Remove the air duct plate (Figure 4).
- 1.13. Remove the lower/floor seat rail (Figure 4).
 - a. Cut sealant at each end.
 - b. Underneath the vehicle, unscrew the 3 nuts.
 - c. Keep the rail, the 3 bolts, the 3 square plates, the 3 washers and the 3 nuts.
- 1.14. Remove the melamine panels (Figure 4).
 - a. Remove the melamine panel between the windows. If needed, loosen or remove the windows clamping (the melamine panel is fragile, especially the corners).
 - b. Remove the trim and the lower melamine panel.
- 1.15. Open the ITS box and lower the shelf.

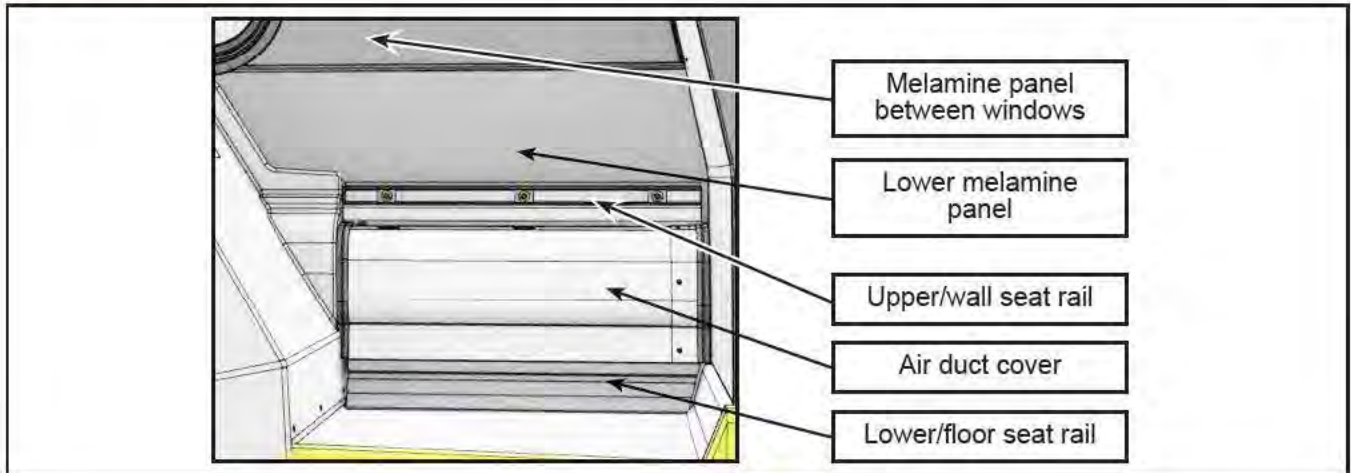

Figure 4 - Components to Remove (Typical)

- 1.16. Remove the ventilation duct (Figure 5).
 - a. Disconnect the electrical cable and unscrew the 4 screws to remove the blower (Figure 6). Keep the 4 screws and the 4 locknuts.

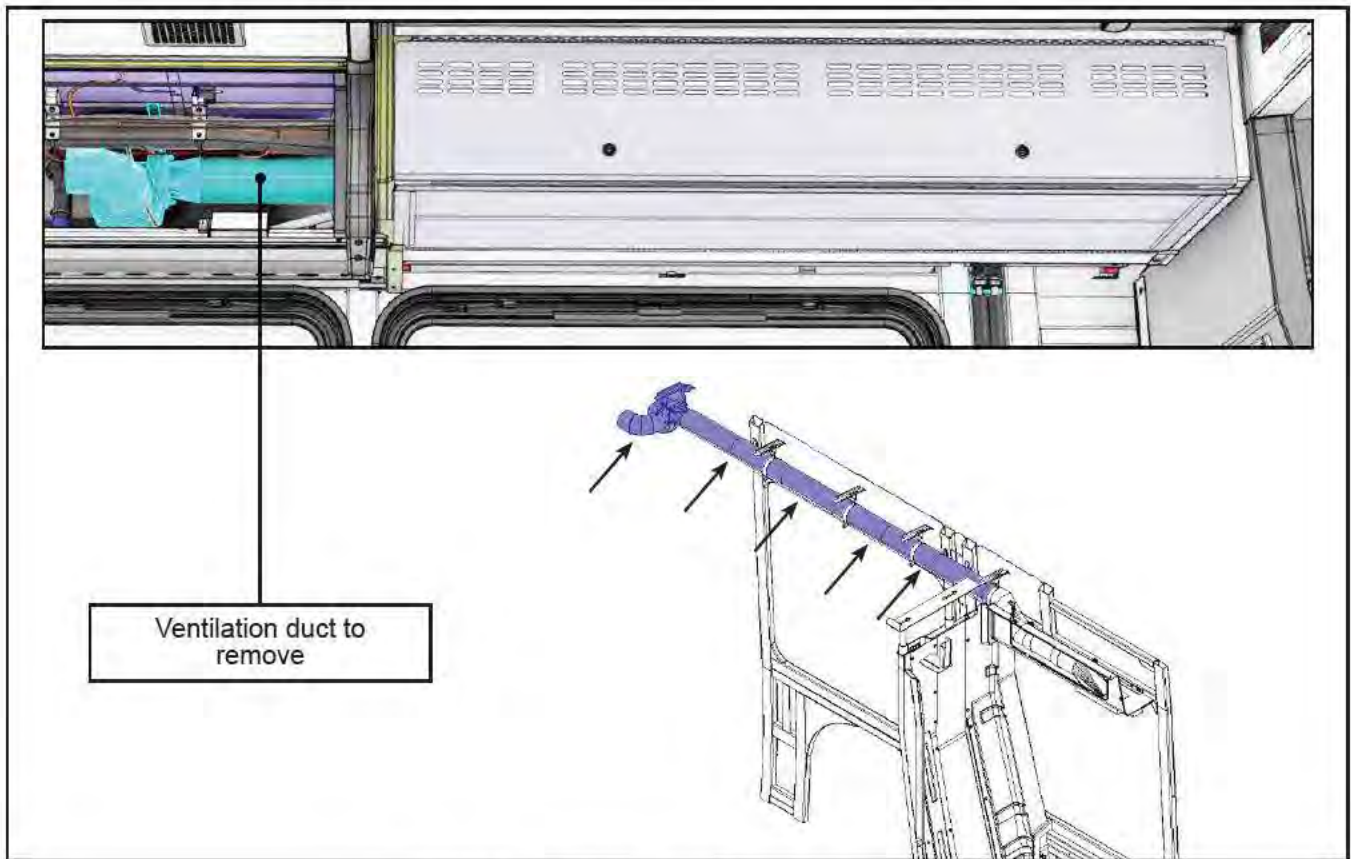

Figure 5 - Ventilation Duct to Remove (Typical)

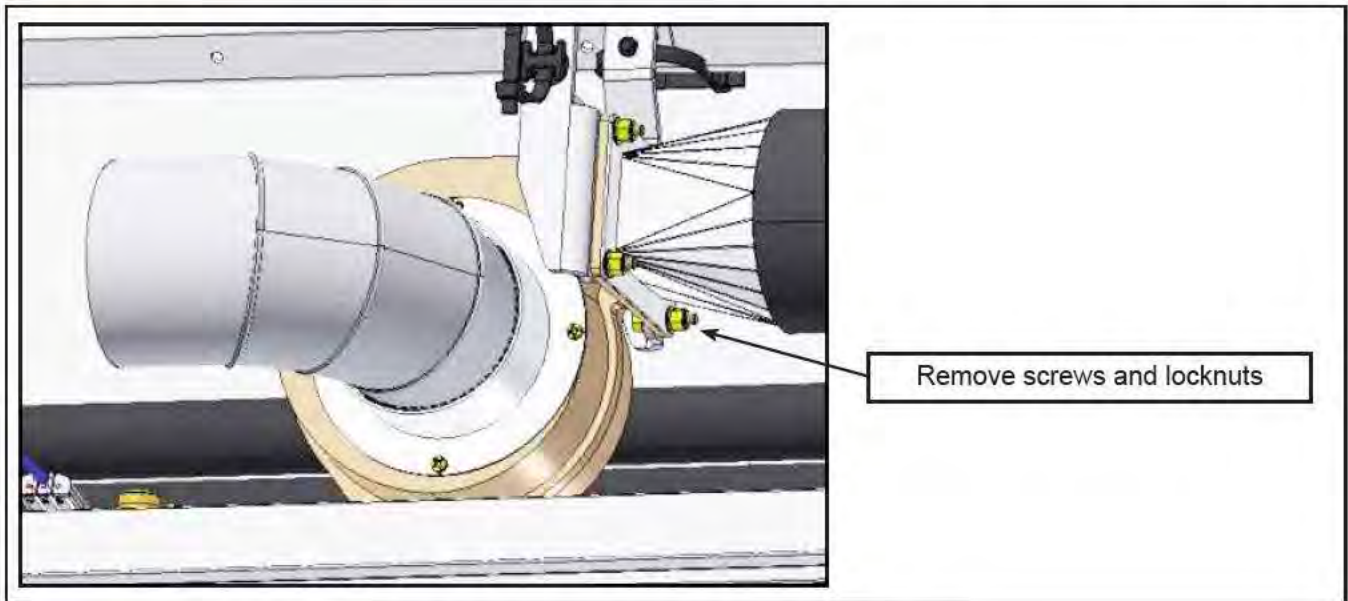

Figure 6 - Remove the Ventilation Blower (Typical)

- b. Open the 3 support clamps. Unscrew the screw, lift the removable section of the support clamp and remove (Figure 7). Keep all parts and hardware.

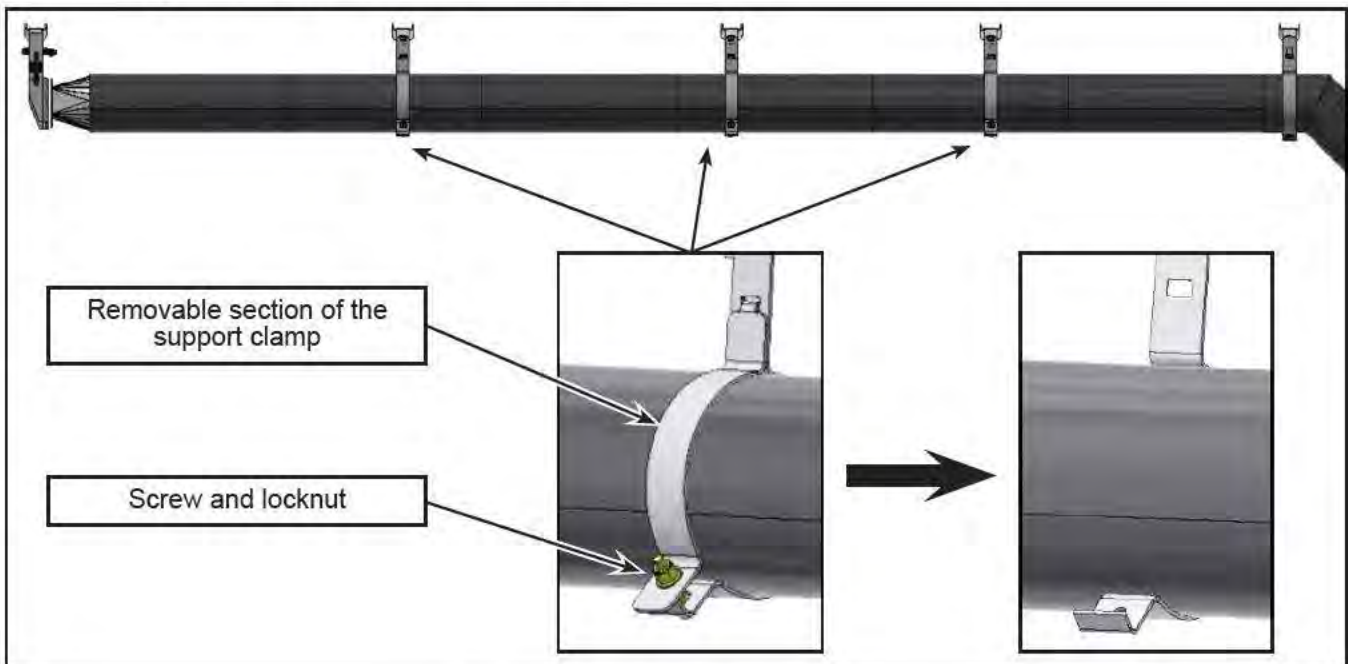

Figure 7 - Open the Support Clamps

- c. Remove the insulation and the aluminum foil tape over the duct joints (Figure 8). It might be difficult to find the joints under the insulation, rotate a section back and forth to see where the joint is, the insulation should deform or stretch over it.



Figure 8 - Remove the Insulation and the Aluminum Foil Tape

- d. Slide out and remove the 3 sections of duct one by one starting with the one on the blower side (Figure 9).

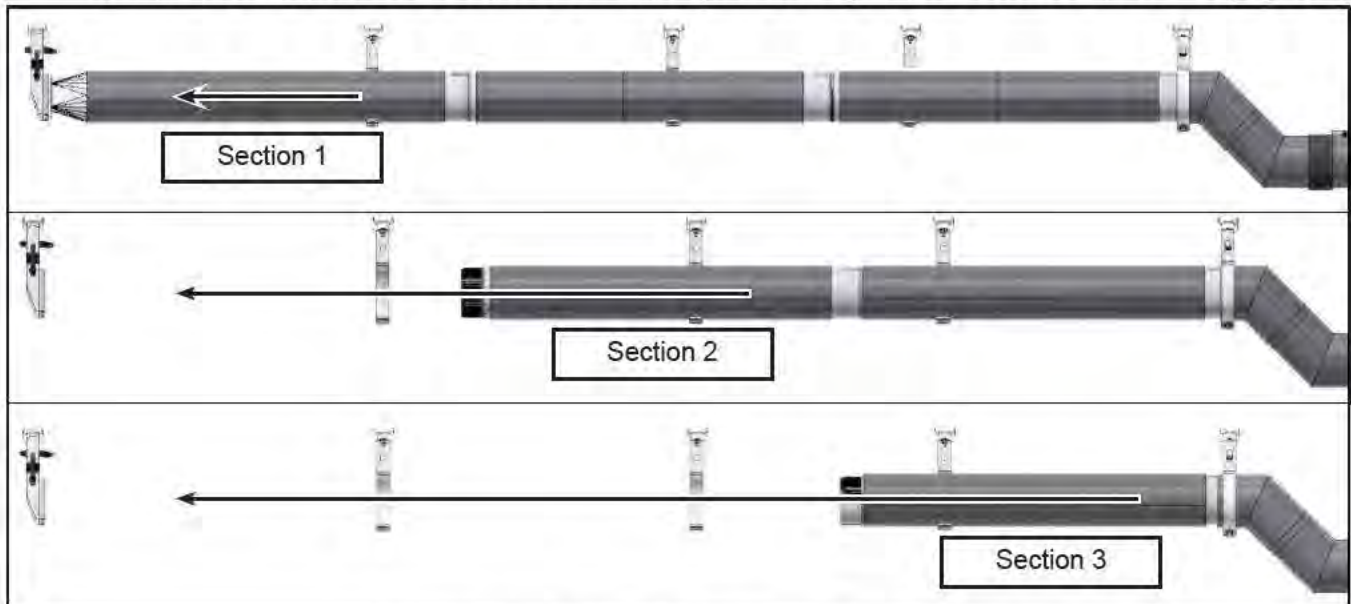

Figure 9 - Slide Out and Remove 3 Sections of Duct

- 1.17. To access the hydraulic pipe N77549-01 connection, cut cable ties securing the Pex Pipes to their support bracket to move them away (Figure 10).

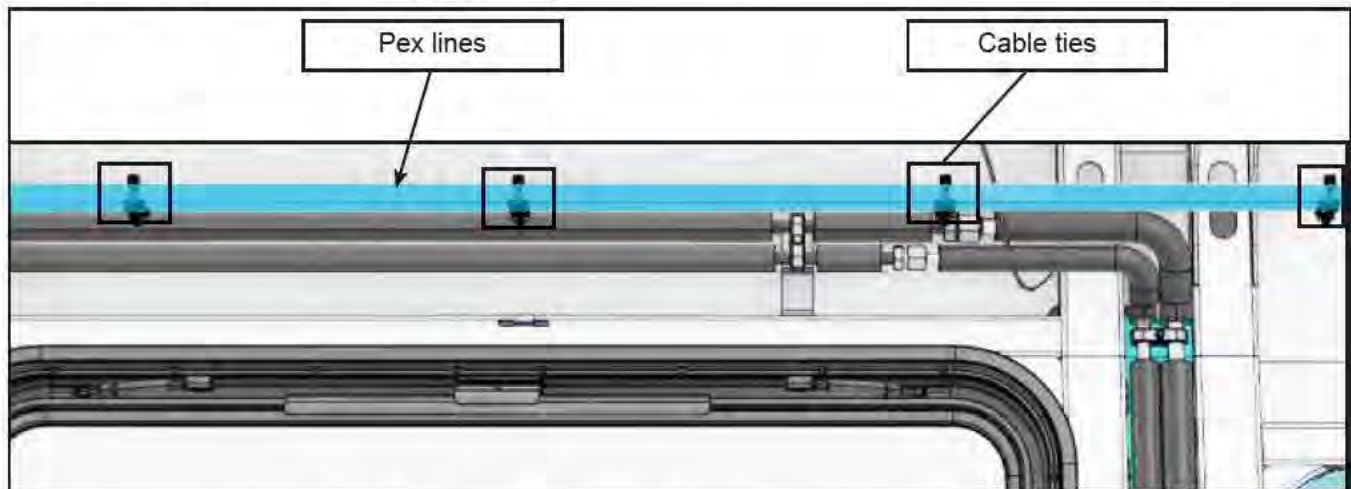

Figure 10 - Pex Lines - Cable Ties to Remove (Components Omitted for Clarity)

REMOVE HYDRAULIC PIPE N77549-01

- 1.18. Locate hydraulic pipe N77549-01 (Figure 11).
- 1.19. Remove the 2 support brackets.
- 1.20. Remove the hydraulic pipe N77549-01.
- Disconnect the ORS fitting at each end of pipe N77954-01 (note: a small amount of oil will pour).
 - Remove the pipe N77549-01.

INSTALL NEW HYDRAULIC PIPE N77549-01

- 1.21. Install new insulation N26360 on the new hydraulic pipe N77549-01 as on the old one.
- 1.22. Install the pipe N77549-01 in the vehicle and hand tighten the ORS fittings.
- 1.23. Tighten the 2 ORS fittings to the torque value of 48 lb-ft (65 N·m).



Refer to the maintenance manual, section 99: *General Practices*, for **ORS-TYPE FITTING INSTALLATION**.

- 1.24. Reinstall the 2 support brackets.
- 1.25. Discard the old hydraulic pipe N77549-01.

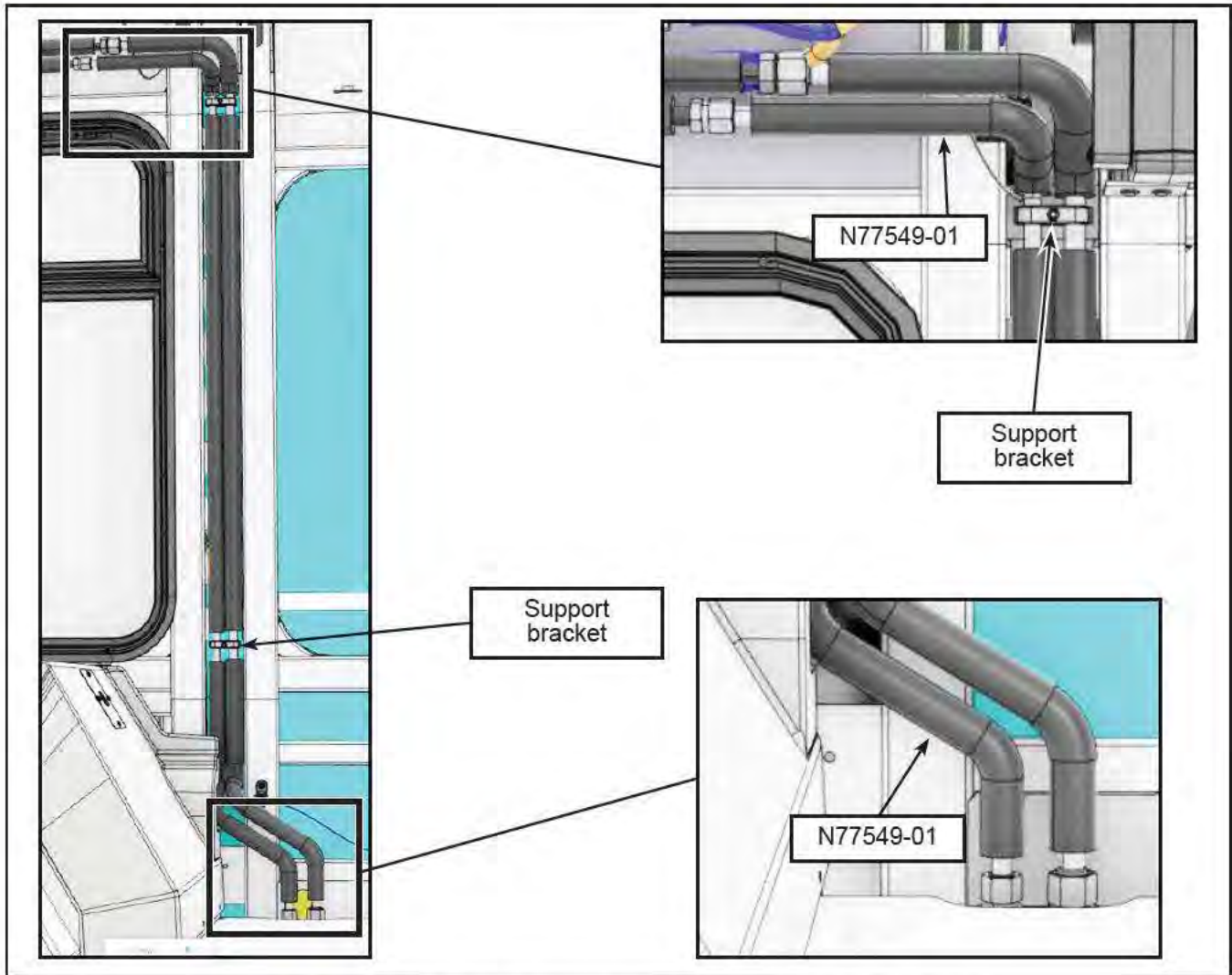

Figure 11 - Hydraulic Pipe N77549-01 (Components Omitted for Clarity)

REFILL HYDRAULIC RESERVOIR



NOTE

Refer to the maintenance manual, section 09: *Engine and Cooling*, for **HYDRAULIC OIL FILLING PROCEDURE**.

- 1.26. Fill the hydraulic oil reservoir to the required level.
- 1.27. Start the vehicle and turn the steering wheel back and forth.
- 1.28. Inspect pipe N77549-01 connections to ensure there are no leaks.
- 1.29. Stop the engine.

CLEAN AND CLOSE**CLEAN**

- 1.30. Clean any excess oil.

CLOSE ACCESS

- 1.31. Reposition the Pex lines and secure with the cable ties G5007996 (ref. Figure 10).
- 1.32. Reinstall the ventilation duct.
- Slide back in the 3 sections of duct at their original position (ref. Figure 9).
 - Seal the 3 duct joints with the new aluminum foil tape N66955.
 - Install new insulation over the aluminum foil tape by cutting the required widths in the new insulation sheet N85710-13 to replace the pieces removed at step 1.16.c (ref. Figure 8).
 - Reinstall the blower on its support bracket with the 4 M6x25 screws and the 4 locknuts (ref. Figure 6).
 - Close the 3 support clamps with the removed support clamp section and secure with the M6x30 screw and the locknut (ref. Figure 7).
 - Reconnect the blower electrical cable.
- 1.33. Reinstall the melamine panels and the between trim (don't forget to pass thru any electrical cables).
- 1.34. Reinstall the chime.
- Pass the electrical cable thru the pass hole.
 - Apply new thread locker, Loctite 242 (Nova Bus #9985283) or equivalent, on the two M5 x 25 mm screws. Reinstall chime on the wall with the two 1/2 in. spacers.
 - Reconnect the 2 terminals to the terminal strip.
 - Reinstall cover with the 4 screws.
- 1.35. Reinstall the first fluorescent light, the curtains, if applicable and the access panel.
- 1.36. If the windows clamping was loosened or removed, reinstall with new screws N73848. Torque the screws.

**NOTE**

Refer to the maintenance manual, section 03: Windows, Windshield and Accessories, for the TORQUE SEQUENCE AND VALUE.

- 1.37. Reinstall the floor rail in the same position with the removed hardware: 3 M10 mushroom square bolts, 3 square plates, 3 M10 oversize washers and 3 M10 nuts.
- Clean the 3 bolts to remove any old anti-seize compound and dirt.
 - Reinsert the 3 bolts and the 3 square plates into the rail.
 - Put the rail in place inserting the bolts into the floor. Position the rail like before.
 - Underneath the vehicle, apply new anti-seize compound, NeverSeez (Nova Bus #R085023) or equivalent, on bolts and install the 3 washers and the 3 nuts.
 - Torque the nuts to the torque value show in Figure 12 and apply torque seal on nuts.
 - Apply sealant Sikaflex 552 N35535-01 to both ends of the rail to fill in the gaps.
- 1.38. Reinstall the air duct plate.

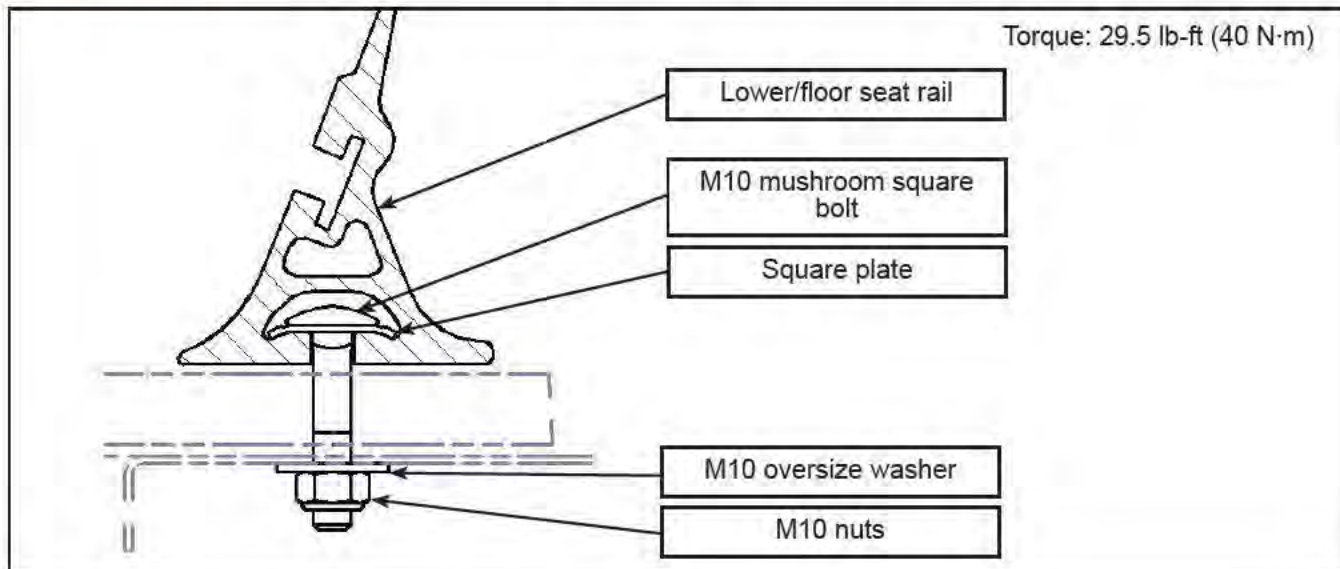

Figure 12 - Lower/Floor Seat Rail

- 1.39. Reinstall the upper/wall rail with the removed hardware: 3 M10 screws and 3 rectangular retainers.
- Clean the screws and the rivnuts to remove the old thread locker.
 - Apply new thread locker, Loctite 242 (Nova Bus #9985283) or equivalent, on screws.
 - Install the rail with the 3 rectangular retainers and the 3 screws. Hand tighten.
 - From the rear to the front, make a first tightening to the torque value shown in Figure 13.
 - Again from the rear to the front make a second tightening to the same torque value.
 - Apply torque seal on bolts.
 - Apply sealant Sikaflex 552 N35535-01 to both ends of the rail to fill in the gaps.

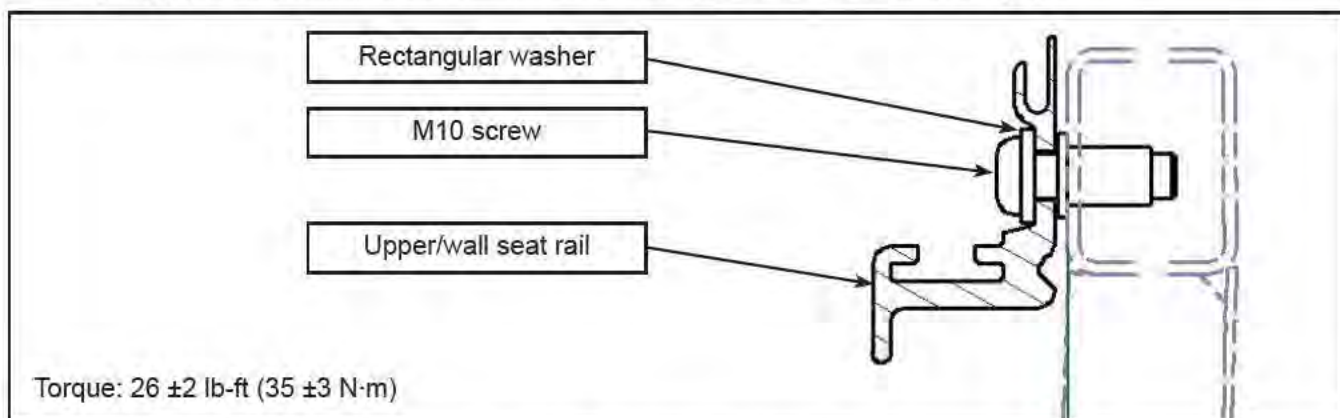

Figure 13 - Upper/Wall Seat Rail

- 1.40. Reinstall the transversal seat.
- Reinstall the spacers to their original position. To ease the installation, the spacers can be temporarily glued with cyanoacrylate adhesive Loctite 414 (Nova Bus #9985337) or equivalent.
 - Reinstall seat and secure with the 8 washers, the 8 lock washers and the 8 screws.
 - Torque the screws to the torque value shown in Figure 14.
 - Apply torque seal on screws.
 - If applicable, reconnect any electrical connection and secure with cable ties.

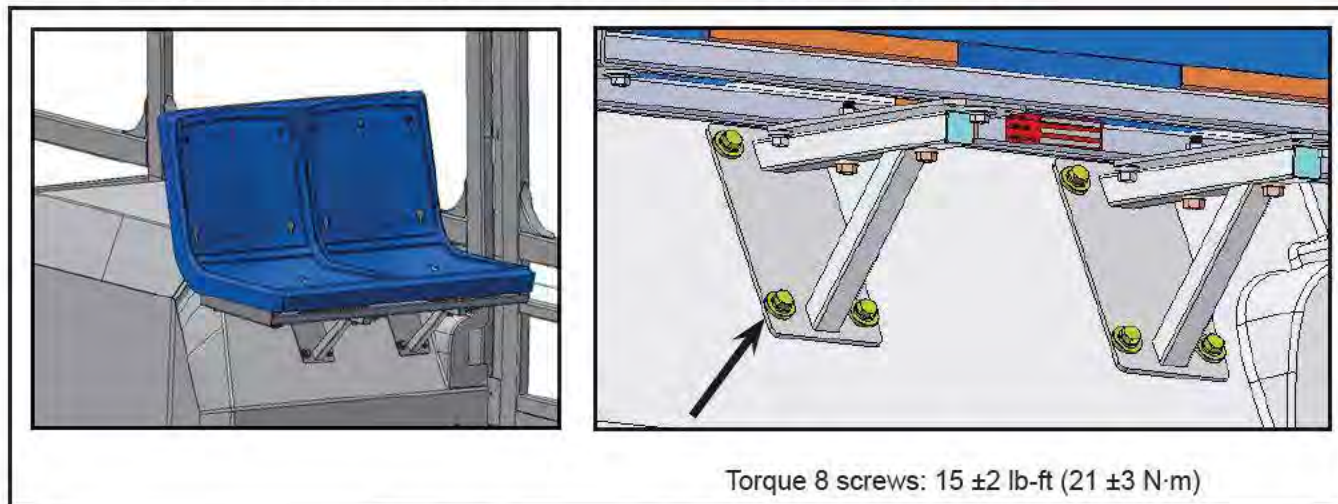

Figure 14 - Torque to Apply for Transversal Seat (Typical)

- 1.41. The vehicle can return in service. ❖