



Revised March 2021

Dealer Service Instructions for:

## **Safety Recall W68 / NHTSA 20V-475 Loss of Crankshaft Position**

---

**NOTE: The Skid Plate labor operation numbers have been updated.**

### **Remedy Available**

**2014-2016 (DS) Ram 1500 Pickup**

**2014-2016 (WK) Jeep® Grand Cherokee**

*NOTE: This recall applies only to the above vehicles equipped with a 3.0L engine (sales code EXF).*

*NOTE: Some vehicles above may have been identified as not involved in this recall and therefore have been excluded from this recall.*

**IMPORTANT: Some of the involved vehicles may be in dealer used vehicle inventory. Dealers should complete this recall service on these vehicles before retail delivery.** Dealers should also perform this recall on vehicles in for service. Involved vehicles can be determined by using the VIP inquiry process.

### **Subject**

The magnetic material attached to the tone wheel on about 240 of the above vehicles provides a signal to the crankshaft position sensor. If this signal material is lost, the engine loses its ability to synchronize injector pulses and cam timing. This loss of crankshaft position can result in an engine stall, as well as loss of the ability to restart the engine. A loss of motive power can cause a vehicle crash without prior warning.

## Repair

Replace the tone wheel.

## Alternate Transportation

Dealers should attempt to minimize customer inconvenience by placing the owner in a loaner vehicle if inspection determines that tone wheel replacement is required and the vehicle must be held overnight.

## Parts Information

<u>Part Number</u>	<u>Quantity</u>	<u>Description</u>
68493358AA	1	Crankshaft Tone Wheel (DS/WK)
68161231AA (MSQ 8)	8	Bolt, Flex Plate (DS/WK)
68163849AB (MSQ 4) U.S.) (MS-12106)	1	OAT Coolant - 50/50 Pre-diluted (DS/WK)
06105052AA	1	Bolt, Hex Flange Head (WK)
06104709AA	1	Nut, Hex Flange, M8x1.25x8.0 (WK)
68350252AA	1	Gasket, SRC flange (WK)
06511398AA	6	Nut, ball joint, tie rod, stabilizer link (WK)
06512111AA	2	Bolt, lower control arm to clevis (WK)
06512099AA (MSQ 2)	2	Nut, lower control arm to clevis (WK)
68157479AA	1	A/C O-Ring (WK)
68086126AA	1	A/C O-Ring (WK)
06510206AA	1	Steering Column Pinch Bolt (WK)
68359475AA	1	Clamp, SCR to Turbo (WK)
68357407AA	1	Gasket, SCR to Turbo (WK)
68234976AA	1	Gasket, DEF Injector (WK)
CSRGW681AA	1	Wire Harness Clips (DS/WK)

## **Parts Return**

No parts return required for this campaign.

## **Special Tools**

**The following special tools are required to perform this repair:**

- C-4150A                      Ball Joint Press
- 9546                              Disconnect Tool (part of kit number 9590)
- 8875A                            Disconnect Tool (part of kit number 9575)

## Service Procedure

### Jeep Grand Cherokee

This procedure is written for 4wd Grand Cherokees. For 2wd vehicles, use the same LOPs and steps without 4wd specific components.

#### A. Remove

1. Disconnect the negative battery cable.
2. Partially lift the vehicle.
3. Remove the front wheels and tires.
4. Raise and support the vehicle.
5. Apply penetrating oil to the upper ball joint nuts, upper sway bar end link nuts, and strut rod clevis nuts.
6. Remove the transmission splash shield (Figure 1).

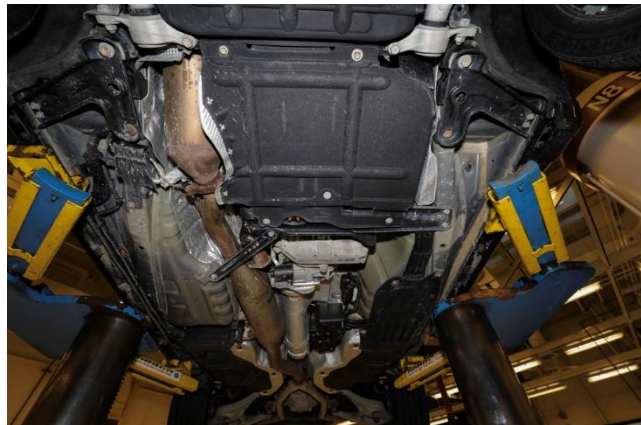
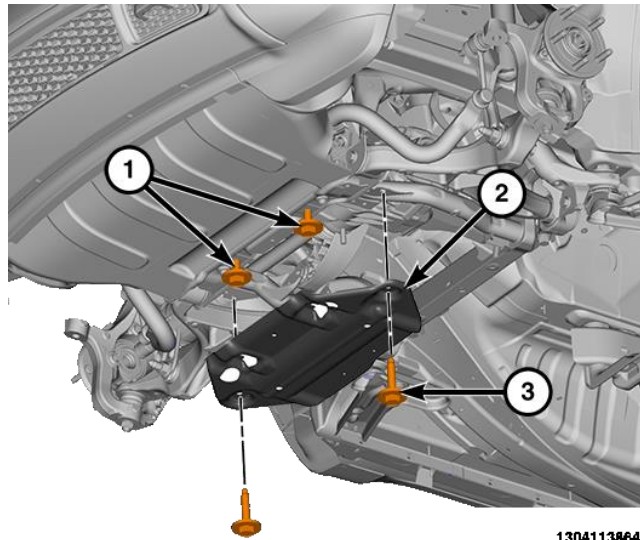


Figure 1 – Transmission Splash Shield

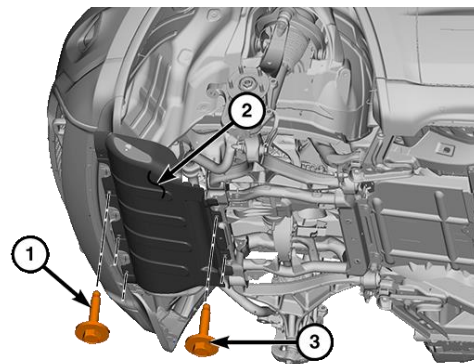
**Service Procedure [Continued]**

7. Loosen the front bolts (1) for the front suspension skid plate (if equipped) (Figure 2).
8. Remove the rear bolts (3) and remove the skid plate (2) (Figure 2).



**Figure 2 – Front Suspension Skid Plate**

9. Remove the front skid plate (2) (Figure 2).
10. Remove the front cover (Figure 3).



**Figure 3 – Front Cover**

**WARNING:** Do not remove the cylinder block drain plugs or loosen the radiator draincock with system hot and under pressure. Serious burns from coolant can occur.

**NOTE:** DO NOT WASTE reusable coolant. If the solution is clean, drain the coolant into a clean retainer for reuse.

**Service Procedure [Continued]**

11. DO NOT remove radiator cap first. With engine cold, locate radiator draincock.

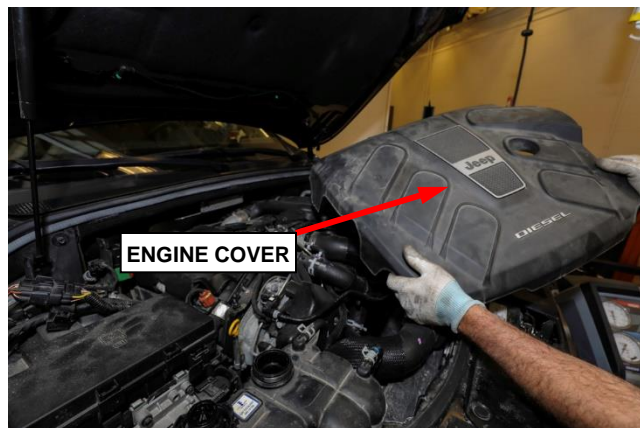
**NOTE: Radiator draincock is located in the radiator tank at the bottom left corner.**

12. Attach one end of a hose to the draincock. Put the other end into a clean container. Open draincock and drain coolant from radiator. This will empty the coolant reserve/overflow tank. The coolant does not have to be removed from the tank unless the system is being refilled with a fresh mixture. When tank is empty, remove radiator cap and continue draining cooling system.

13. Lower the vehicle to working height.

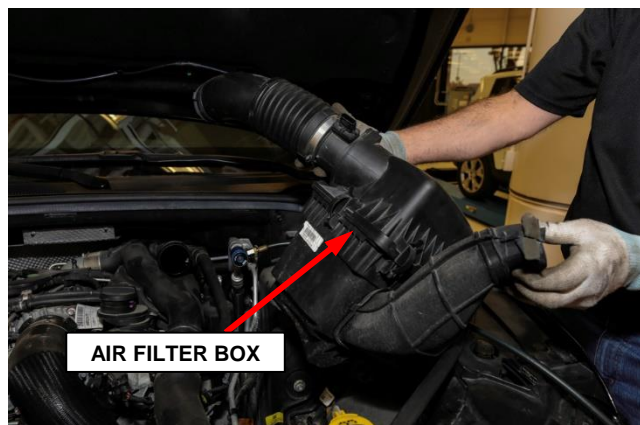
14. Evacuate the air conditioning system.

15. Remove the engine cover (Figure 4).



**Figure 4 – Engine Cover**

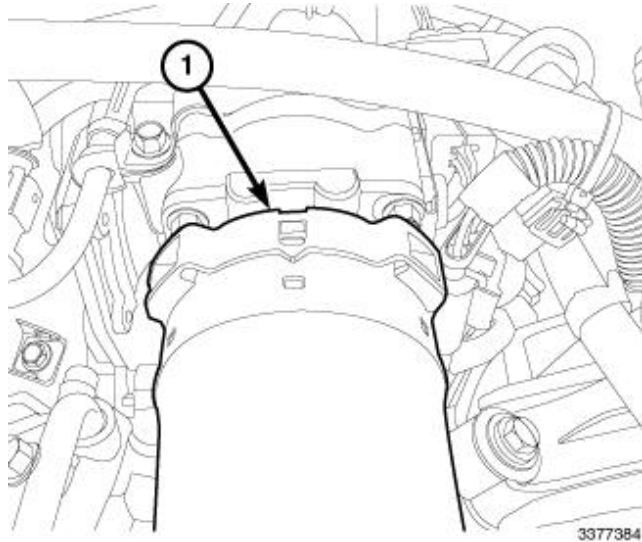
16. Remove the MAF sensor connector, the air filter box and intake tube (Figure 5).



**Figure 5 – Air Filter Box**

**Service Procedure [Continued]**

17. Remove the resonator to turbocharger Charge Air Cooler (CAC) hose.
18. Disconnect the CAC hose (1) from the EGR air flow control valve (Figure 6).



**Figure 6 – Charge Air Cooler Hose**

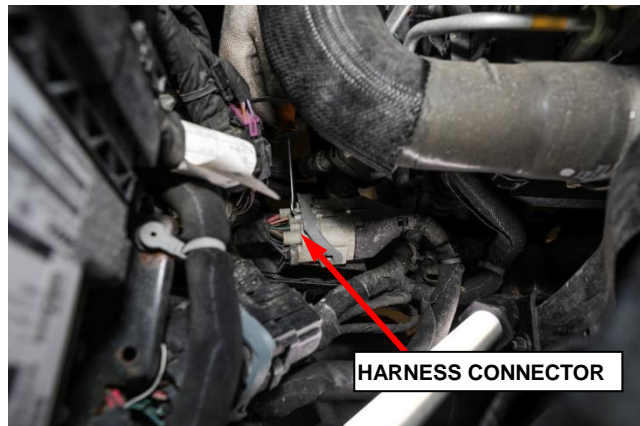
19. Remove the vacuum booster hose at the vacuum pump.
20. Remove the upper and lower radiator hoses from the engine.
21. Remove the two bolts retaining the coolant reservoir to the body, and set it aside (Figure 7).



**Figure 7 – Coolant Reservoir**

**Service Procedure [Continued]**

22. Disconnect the main wiring harness (Figure 8).



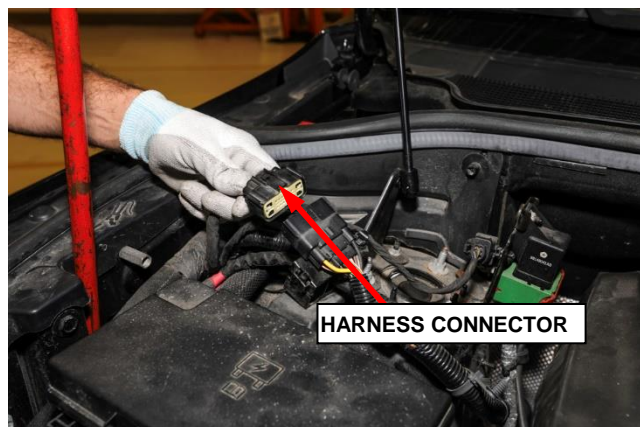
**Figure 8 – Harness Connector**

23. Disconnect the harness from the PCM (Figure 9).



**Figure 9 – PCM Connector**

24. Disconnect the 16-pin connector at the strut tower (Figure 10).

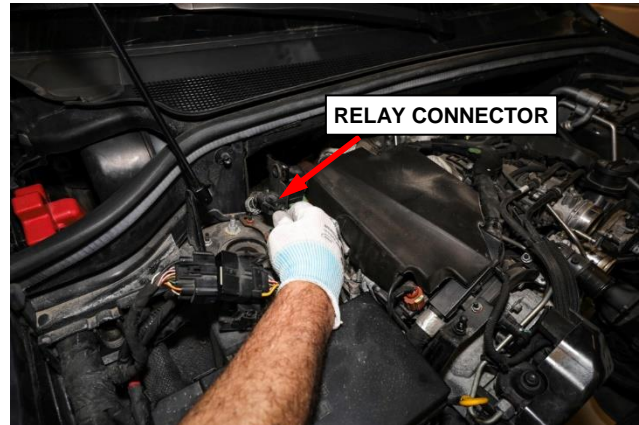


**Figure 10 – Connector at Strut Tower**



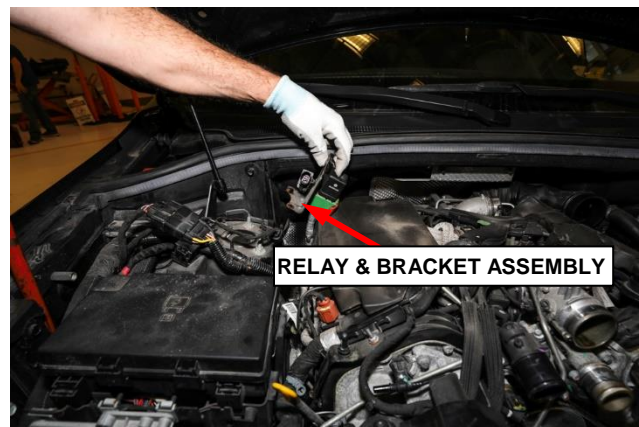
**Service Procedure [Continued]**

25. Disconnect the connector at the relay and bracket on the strut tower (Figure 11).



**Figure 11 – Relay Connector**

26. Remove the two nuts and relay and bracket assembly from the strut tower (Figure 12).

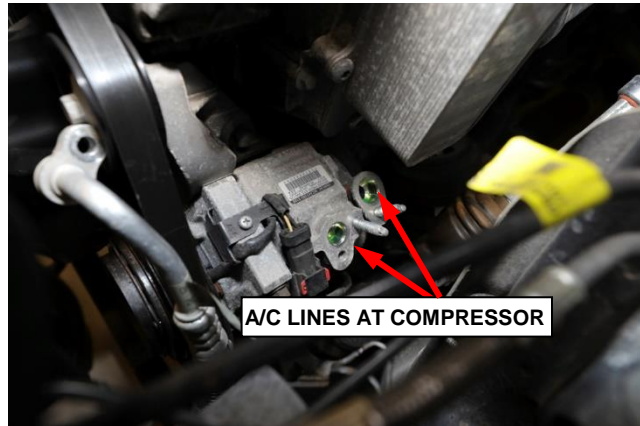


**Figure 12 – Relay and Bracket Assembly**

27. Remove the positive battery cable from the fuse block.
28. Remove the positive battery cable from the jump start terminal, and remove the cable from under the cowl extension.
29. Remove the ground terminal from the body.
30. Disconnect the transmission cooler lines from the radiator and cap the openings.

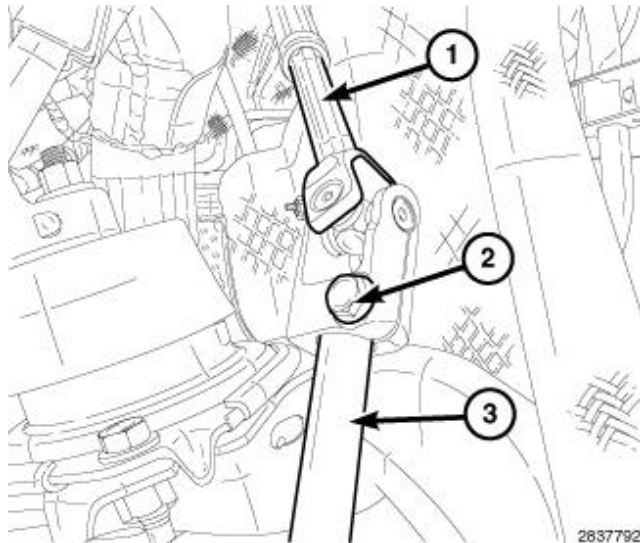
**Service Procedure [Continued]**

31. Remove the nuts and disconnect the A/C suction line and A/C discharge line to the A/C compressor (Figure 13).



**Figure 13 – A/C Lines at Compressor**

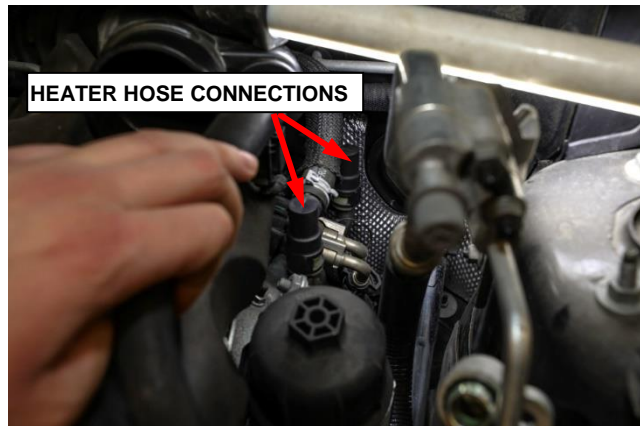
32. Install plugs or tape over all of the opened refrigerant line fittings and the compressor ports.
  
33. Remove the intermediate steering shaft pinch bolt (2) and separate it (Figure 14).



**Figure 14 – Steering Shaft Pinch Bolt**

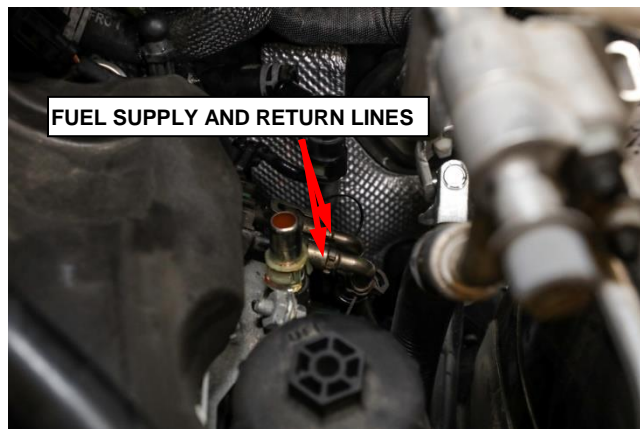
**Service Procedure [Continued]**

34. Disconnect the two hose heater hoses (Figure 15).



**Figure 15 – Heater Hose Connections**

35. Disconnect the low pressure fuel supply and return line quick connect fittings by the brake booster (Figure 16).



**Figure 16 – Fuel Supply and Return Lines**

36. Raise the vehicle half way up.
37. Remove the ABS wire clip from the frame (Figure 17).



**Figure 17 – ABS Wire Clip**

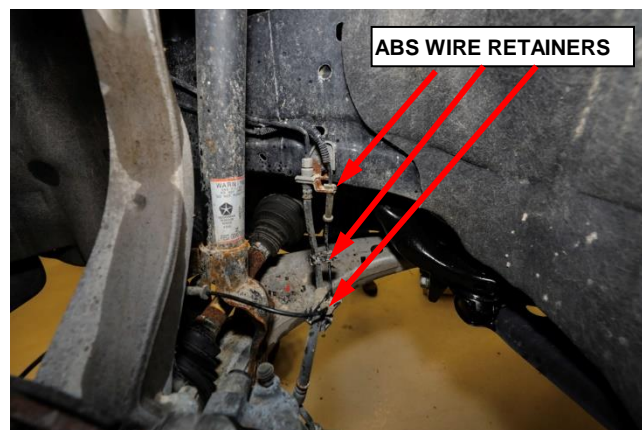
**Service Procedure [Continued]**

38. Disconnect the ABS wire connectors on both sides of the vehicle (Figure 18).



**Figure 18 – ABS Wire Connector**

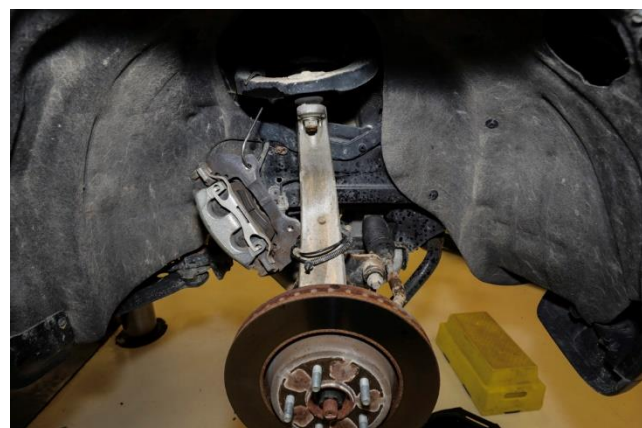
39. Disconnect the three ABS wire retainers on each side. Set the wires aside (Figure 19).



**Figure 19 – ABS Wire Retainers**

40. Bottom the caliper pistons in each caliper.

41. Remove the brake caliper bracket bolts, and hang the bracket caliper assemblies out of the way (Figure 20).



**Figure 20 – Brake Caliper Assembly**

**Service Procedure [Continued]**

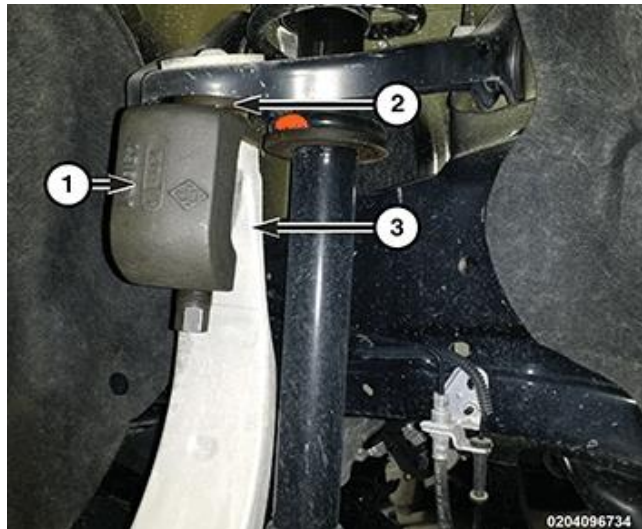
42. Remove the upper ball joint retaining nuts from the ball joints (Figure 21).



**Figure 21 – Ball Joint Nut**

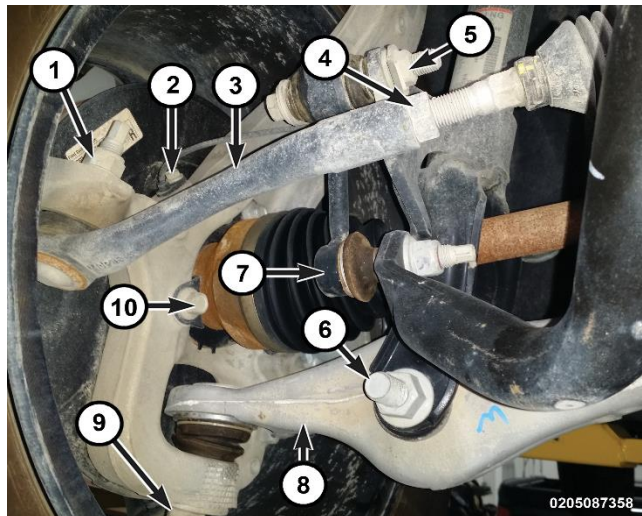
43. Disconnect the upper sway bar link nut on each side.

44. Separate the upper ball joint (2) from the knuckle (3) using Ball Joint Press C-4150A (1) on each side (Figure 22).



**Figure 22 – Ball Joint Press C-1450A**

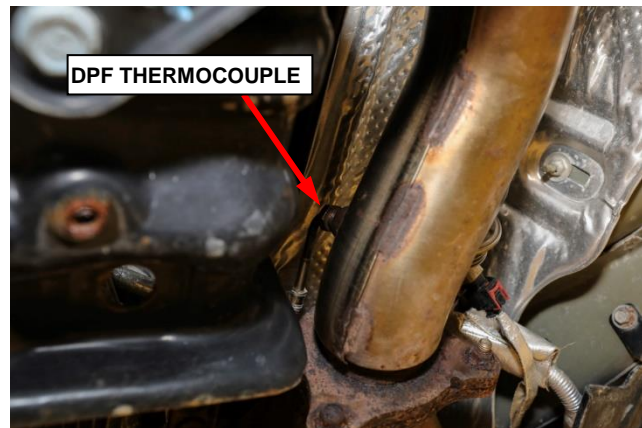
45. Remove the clevis to lower control arm bolt/nut (6) (Figure 23).



**Figure 23 – Clevis Bolt**

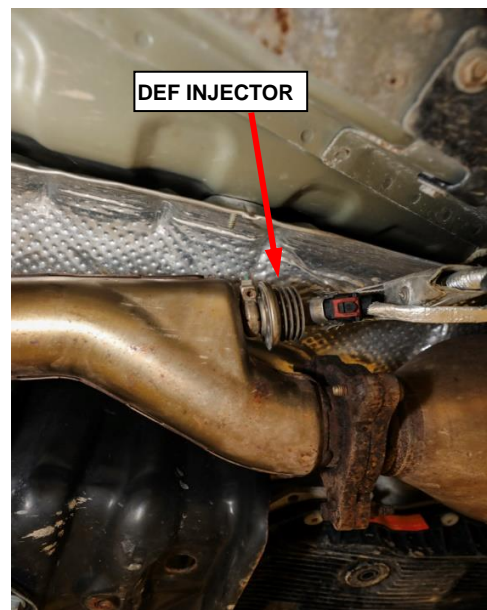
**Service Procedure [Continued]**

46. Raise the vehicle.
47. Remove the lower air suspension compressor support nuts (if required).
48. Remove the thermocouple after the DPF (4/4) (Figure 24).



**Figure 24 – DPF Thermocouple**

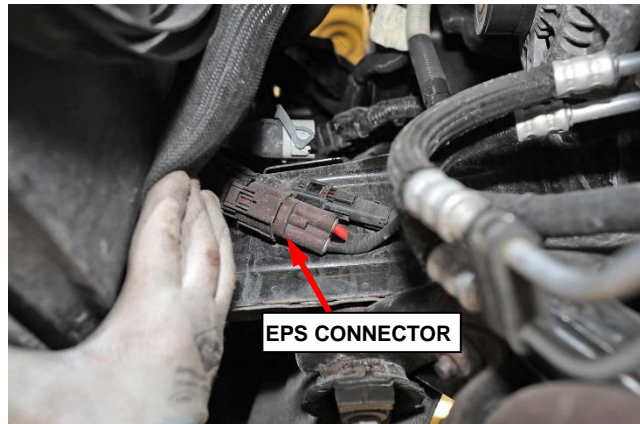
49. Remove the DEF injector clamp and injector (Figure 25).
50. Remove bolts and nuts from the DPF flange.
51. Move the exhaust rearward off of the DPF.



**Figure 25 – DEF Injector**

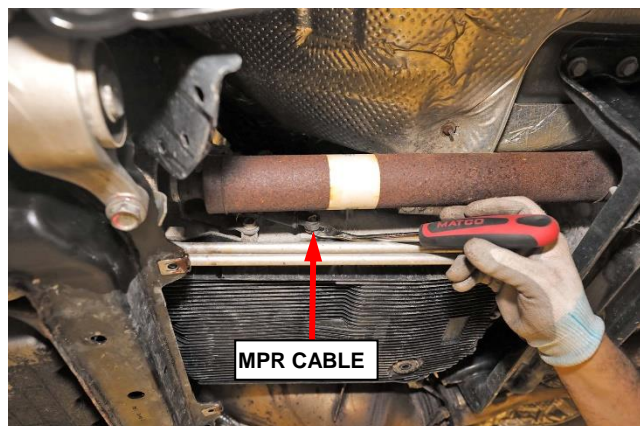
**Service Procedure [Continued]**

52. Separate the EPS connector (Figure 26).



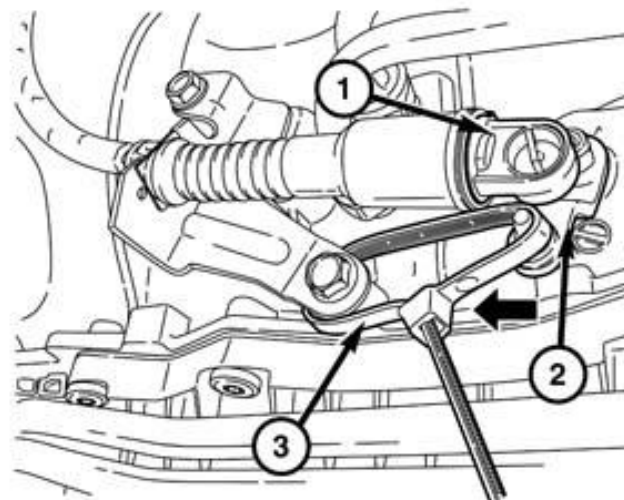
**Figure 26 – EPS Connector**

53. Disconnect the MPR cable from the lever, and set it aside (Figure 27).



**Figure 27 – MPR Cable**

54. Rotate the MPR lever (2) forward to engage neutral position and secure it with a suitable zip tie (3) (Figure 28).
55. Release the locking tab from the MPR cable and remove from the bracket.



**Figure 28 – MPR Cable**

211874

**Service Procedure [Continued]**

- 56. Remove the fuel filter/water separator assembly mounting bolts, and hang the filter assembly to the side (Figure 29).
- 57. Remove the rear propeller shaft heat shield.
- 58. Remove the center bearing heat shield.



**Figure 29 – Fuel Filter/Water Separator Assembly**

- 59. Remove the six fasteners retaining the propeller shaft to the transfer case (Figure 30).



**Figure 30 – Propeller Shaft at Transfer Case**

- 60. Remove the eight fasteners retaining the propeller shaft to the rear axle (Figure 31).

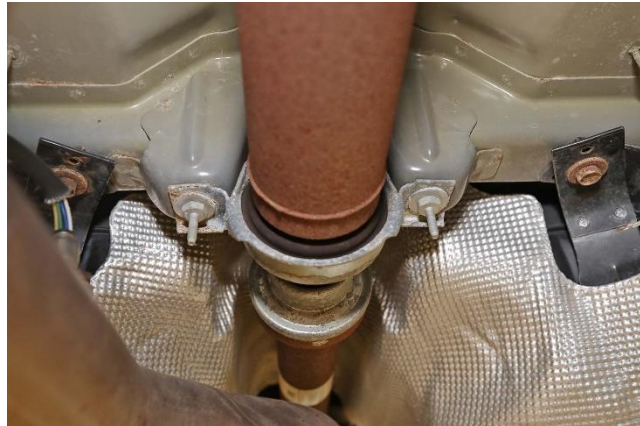


**Figure 31 – Propeller Shaft at Rear Axle**



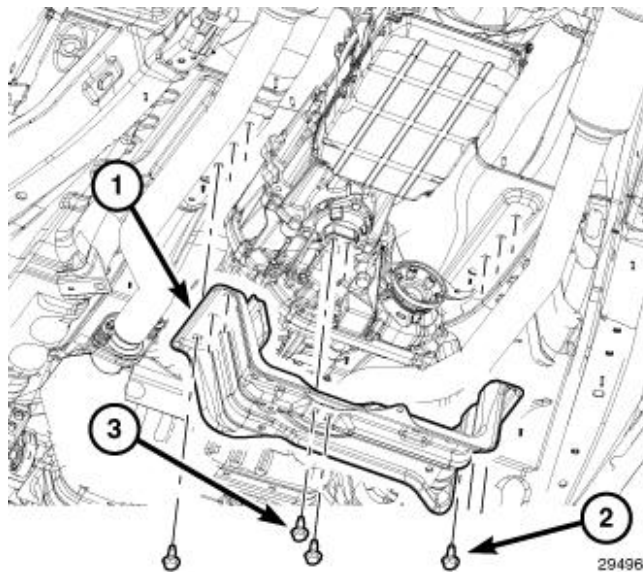
**Service Procedure [Continued]**

- 61. Mark the center bearings orientation. Remove the center bearing fasteners, and the propeller shaft from the vehicle (Figure 32).
- 62. Position a support jack under the transfer case.



**Figure 32 – Center Bearing**

- 63. Remove the transmission mount to crossmember bolts (3) (Figure 33).
- 64. Disconnect the transfer case electrical connector and harness retainer.



**Figure 33 – Transmission Mount Bolts**

- 65. Remove the left and right crossmember brackets.
- 66. Remove the six fasteners (2) securing the transmission crossmember to the vehicle, and remove the crossmember (Figure 33).
- 67. Remove the left and right cradle support brackets.
- 68. Disconnect the NOX sensor 1/1 electrical connector in the right front wheel opening.
- 69. Mark the cradle position with a paint pen.

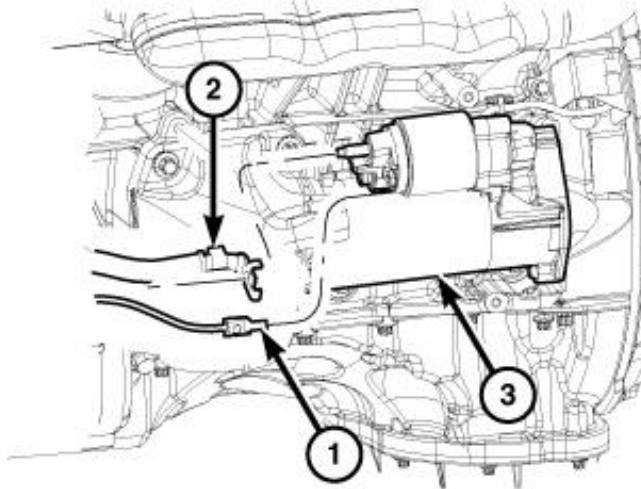
**Service Procedure [Continued]**

- 70. Position a hydraulic lift table under the front cradle (Figure 34).
- 71. Remove the front engine cradle bolts.
- 72. Remove the engine, transmission, transfer case and cradle from the vehicle.



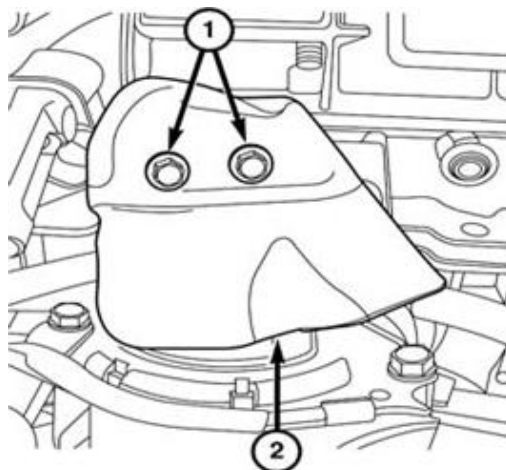
**Figure 34 – Lift Table**

- 73. Remove the starter motor B+ connection (2) (Figure 35).
- 74. Disconnect the solenoid wire harness connector (1) (Figure 35).
- 75. Remove the electrical connectors at the oil filter housing, and the harness retainers at the oil filter housing and bell housing.



**Figure 35 – Starter Connections**

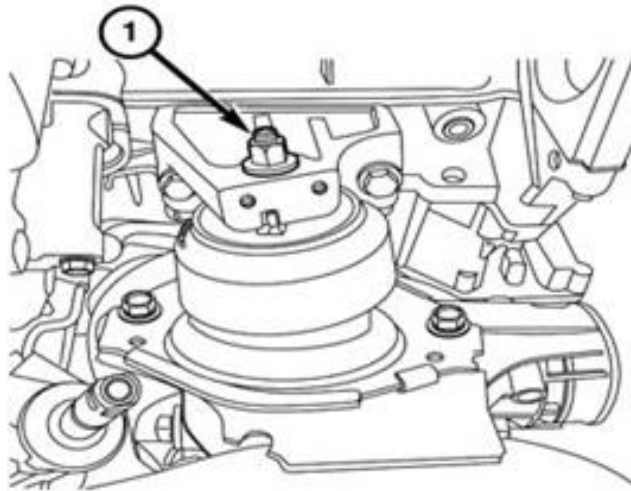
- 76. Remove bolts (1) and the heat shield (2) from the left engine mount (Figure 36).



**Figure 36 – Left Engine Mount Heat Shield**

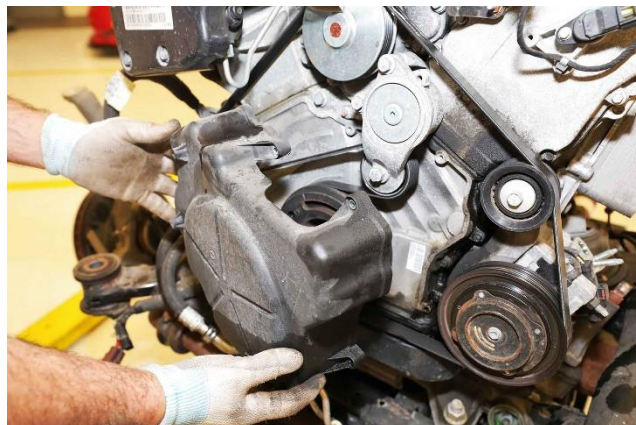
**Service Procedure [Continued]**

- 77. Remove the left engine mount nut (1) (Figure 37).
- 78. Remove the starter motor bolts.
- 79. Using a suitable lifting device, slightly raise up the engine.
- 80. Remove the starter motor.



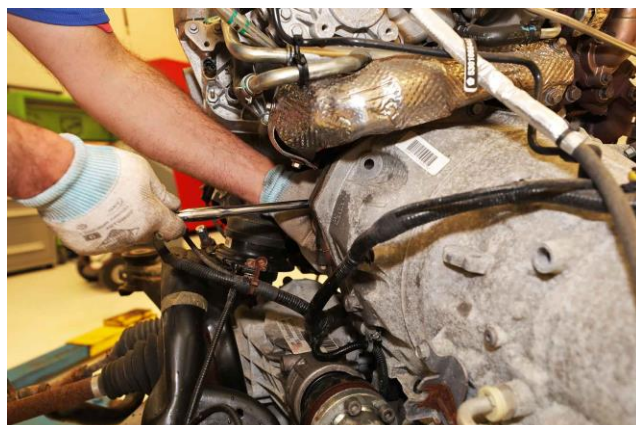
**Figure 37 – Engine Mount Nut**

- 81. Remove the bolts and the vibration damper cover (Figure 38).



**Figure 38 – Vibration Damper Cover**

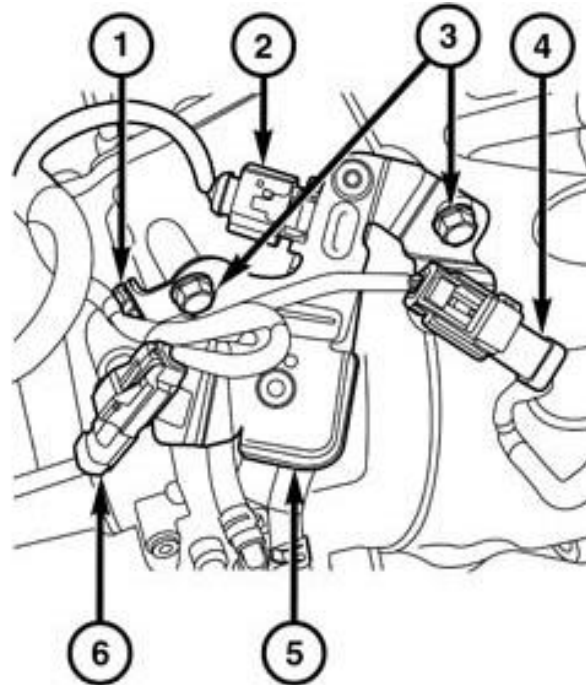
- 82. While holding the crank, remove the torque converter bolts through the start motor opening (Figure 39).



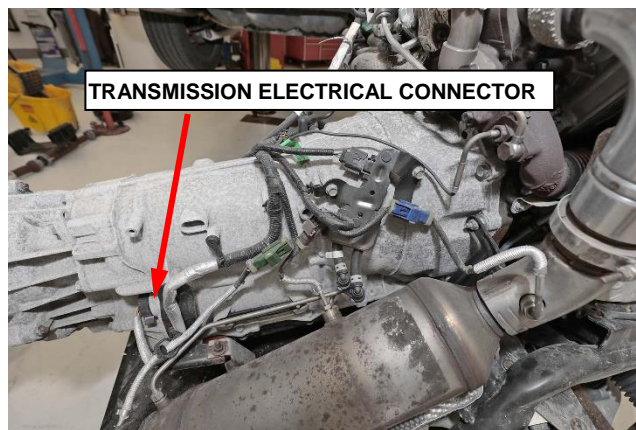
**Figure 39 – Torque Converter Bolts**

**Service Procedure [Continued]**

- 83. Disconnect the Exhaust Gas Temperature (EGT) sensor 1/2 wire harness connector (4) and detach from bracket (5) (Figure 40).
- 84. Disconnect the Catalyst Exhaust Gas Temperature (CEGT) sensor wire harness connector (6) and detach from bracket (5) (Figure 40).
- 85. Disconnect the Differential Pressure Sensor (DPS) wire harness connector (2) (Figure 40).
- 86. Remove the bolts (3) and the DPS sensor with bracket (5) (Figure 40).
- 87. Remove the transmission electrical connector and transmission harness retainers. Unclip all the remaining wiring harness from the transmission (Figure 41).



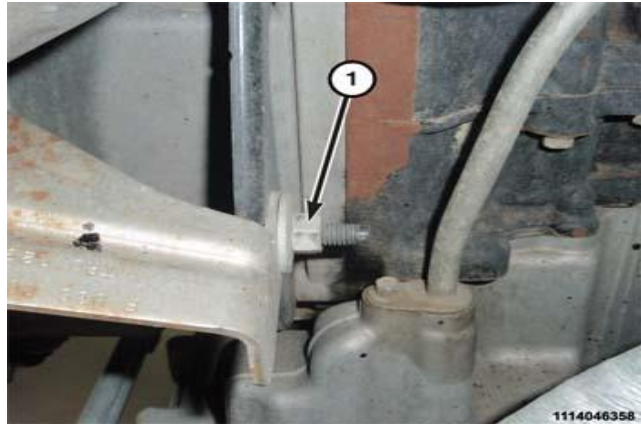
**Figure 40 – EGT/CEGT Sensor Connectors**



**Figure 41 – Transmission Electrical Connector**

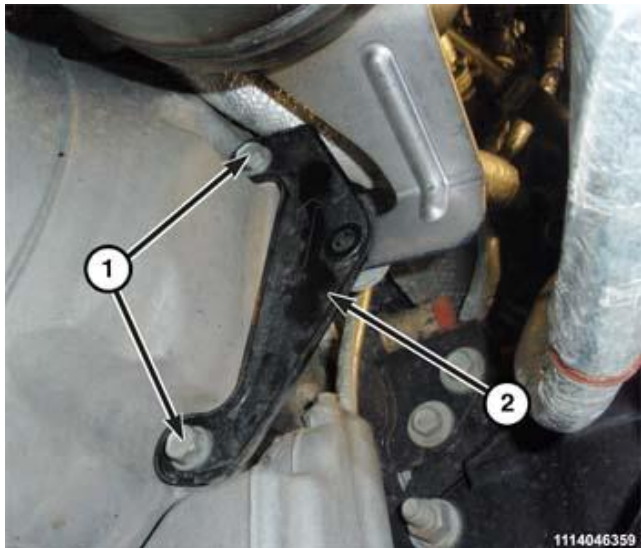
**Service Procedure [Continued]**

88. Remove the front steady bracket retainer nut (1) (Figure 42).



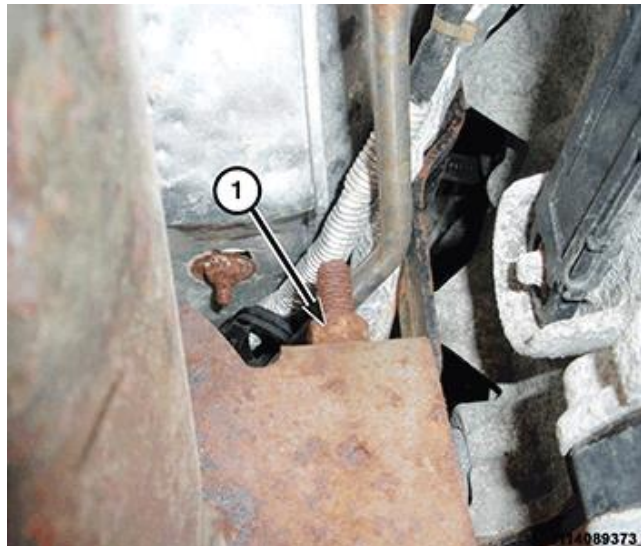
**Figure 42 – Front Steady Rest Bracket Nut**

89. Remove the bolts (1) and the front steady bracket (2) (Figure 43).



**Figure 43 – Front Steady Bracket Bolts**

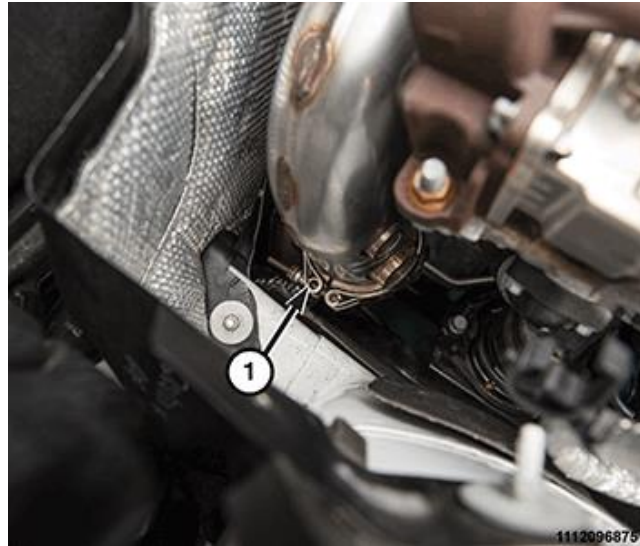
90. Remove the rear steady rest bracket nut and bracket (1) (Figure 44).



**Figure 44 – Rear Steady Rest Bracket Nut**

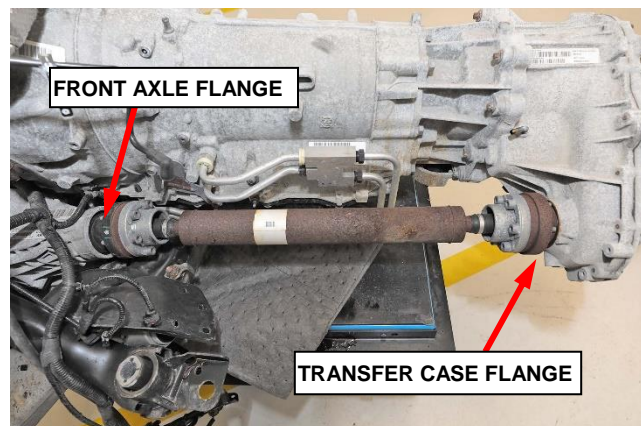
**Service Procedure [Continued]**

91. Loosen the V-band clamp nut (1) and remove the DPF from the turbo (Figure 45).



**Figure 45 – V-band Clamp Nut**

92. Paint mark both ends of the front propeller shaft to the front axle and transfer case flanges (Figure 46).

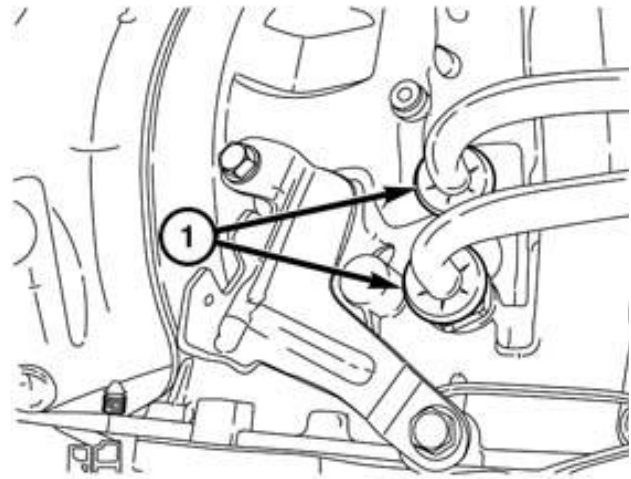


**Figure 46 – Front Propeller Shaft**

93. Remove the front propeller shaft from the front axle (Figure 46).
94. Remove the front propeller shaft from the transfer case (Figure 46).
95. Disconnect the transmission vent hose.
96. Disconnect the transfer case vent hose.

**Service Procedure [Continued]**

- 97. Unclip the Jiffy Tite locking covers (1) and slide them back onto the transmission lines (Figure 47).
- 98. Using Disconnect Tool 9546 remove the trans cooler lines.
- 99. Remove the fasteners securing the transmission cooler.
- 100. Remove the four transmission to oil pan bolts.



2118741

**Figure 47 – Transmission Line Jiffy Tite Covers**

- 101. Support the transmission with a suitable strap (Figure 48).
- 102. Remove the upper bell housing bolts.



**Figure 48 – Transmission Support Strap**

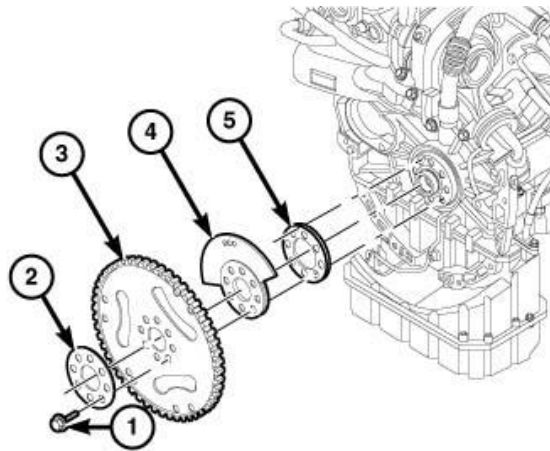
**CAUTION:** The transmission and torque converter must be removed as an assembly to avoid component damage. The converter driveplate, oil pump, or oil seal can be damaged if the converter is left attached to the driveplate during removal. Be sure to remove the transmission and converter as an assembly.

- 103. Remove the transmission from the engine.
- 104. Paint mark the flexplate hub to flexplate relationship.

**Service Procedure [Continued]**

**CAUTION: Do not use an impact socket or a thick walled socket when removing or installing the flexplate retaining bolts, damage to the crankshaft, internal engine or the transmission may occur.**

- 105. Remove the bolts (1), the backing plate (2) and the flexplate (3) (Figure 49).
- 106. Mark the counterweight location.
- 107. Remove the counterweight (4) and tone wheel (5) (Figure 49).



3127573

**Figure 49 – Flexplate Removal**

- 108. Inspect the crankshaft position sensor for damage, and replace as needed.



## **B. Install**

1. Install the **NEW** tone wheel 68493358AA (5) (Figure 49).

**NOTE: Make sure the dowel pin (1) is installed in the dead hole of the counter weight. The other hole is a through hole and is not to be used (Figure 50).**



0311036445

**Figure 50 – Counter Weight Dowel Pin**

**NOTE: Do Not lubricate the NEW bolts as they are already coated with an anti-scuff treatment.**

**NOTE: Always use NEW flexplate bolts whenever the existing bolts have been removed.**

2. Install the counter weight (4) and make sure the dowel pin side is inserted into the crankshaft hole for proper counter weight timing. A vibration can occur if the counter weight is installed incorrectly (Figure 49).
3. Install the flexplate, aligning the paint marks.

**NOTE: With clean engine oil, lubricate the bolt side of backing plate (2).**

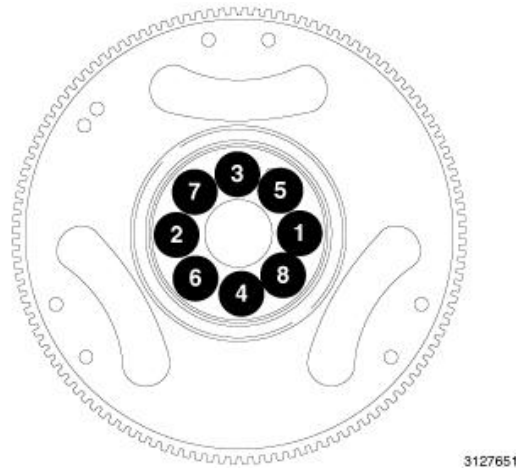
4. Lubricate and install the backing plate (2) and tighten the **NEW** bolts 68161231AA (1) finger tight (Figure 49).

**CAUTION: Do not use an impact socket or a thick walled socket when removing or installing the flexplate retaining bolts, damage to the crankshaft, internal engine or the transmission may occur.**

**Service Procedure [Continued]**

5. Using the tightening sequence shown in Figure 51, tighten bolts to:

- Tighten the bolts 50 N·m (37 ft. lbs.).
- Loosen one bolt at a time and then retighten the bolt in a clockwise cross pattern to 125 N·m (92 ft. lbs.).
- Using a torque angle gauge, tighten each bolt an additional 30 degrees in a clockwise cross pattern.



**Figure 51 – Flexplate Tightening Sequence**

6. Lubricate the nose of the torque converter, and install the transmission to the engine.

**NOTE: Be careful not to damage to transmission pan.**

7. Support the transmission with a suitable strap.
8. Verify that the torque converter spins, and is not bound up.
9. Align torque converter to flywheel holes.
10. Install the upper transmission-to-engine bolts and tighten to 55 N·m (41 ft. lbs.).
11. Install the four transmission-to-oil pan bolts and tighten to 55 N·m (41 ft. lbs.).
12. Install the bolts securing the transmission cooler and tighten securely.
13. Install the transmission cooler lines and be sure the lines are fully seated.
14. Snap the Jiffy Tite lock (1) over the line fitting (Figure 47).
15. Install the clip securing the transmission cooler lines to oil pan.

**Service Procedure [Continued]**

**NOTE: Clean all driveshaft bolts and apply Mopar® Lock AND Seal Adhesive or equivalent to the threads before installation.**

16. Install the front propeller shaft to the transfer case and front axle flanges, aligning the pain marks.
17. Tighten the front propeller shaft bolts in a star pattern to 55 N·m (41 ft. lbs.).
18. Install the Diesel Particulate Filter (DPF) to the turbo and tighten the V-band clamp nut (1) to 10 N·m (89 in. lbs.) (Figure 45). Tap the perimeter of the clamp to seat it, then re-torque to 10 N·m (89 in. lbs.). Repeat until the clamp is seated and holds the torque after taping on it.
19. Install the rear steady rest bracket nut (1) and tighten to 24 N·m (18 ft. lbs.) (Figure 44).
20. Install the front steady bracket (2). Tighten the bolts (1) to 55 N·m (41 ft. lbs.) (Figure 43).
21. Install the front steady bracket nut (1) and tighten to 32 N·m (24 ft. lbs.) (Figure 42).
22. Connect the transmission vent hose.
23. Connect the 13 pin plug connector and turn the connector clockwise to engage (Figure 41).
24. Position and clip the remaining wiring harness to the transmission
25. Install the Differential Pressure Sensor (DPS) and bracket (5) and tighten the bolt (3) to 18 N·m (13 ft. lbs.) (Figure 40).
26. Connect the DPS sensor wire harness connector (2) (Figure 40).
27. Connect the Catalyst Exhaust Gas Temperature (CEGT) sensor wire harness connector (6) and attach to the bracket (5) (Figure 40).
28. Connect the Exhaust Gas Temperature (EGT) sensor 1/2 wire harness connector (4) and attach to the bracket (5) (Figure 40).

**Service Procedure [Continued]**

29. Verify that the torque converter is pulled flush to the flexplate.
30. Install the torque converter bolts and tighten to 42 N·m (31 ft. lbs.).
31. Install the vibration damper cover and tighten the bolts to 10 N·m (89 in. lbs.) (Figure 38).
32. Remove the transmission strap. Lift the engine slightly at the left engine mount.
33. Position the starter and install the mounting bolts. Tighten bolts to 54 N·m (40 ft. lbs.).
34. Install the electrical connectors at the oil filter housing, and the harness retainers at the oil filter housing and bell housing.
35. Connect the solenoid wire harness connector (1) (Figure 35).
36. Install the B+ cable (2) to starter solenoid stud. Tighten nut to 10 N·m (89 in. lbs.) (Figure 35).
37. Lower the engine.
38. Install the left engine mount retaining nut (1) and tighten to 61 N·m (45 ft. lbs.) (Figure 37).
39. Install the heat shield (2). Tighten bolts (1) to 10 N·m (89 in. lbs.) (Figure 36).
40. Align the engine cradle on the lift table with the vehicle. Lower the vehicle onto the engine cradle, aligning it with the previous paint marks (Figure 34).
41. Install the front engine cradle bolts and tighten to 175 N·m (129 ft. lbs.).
42. Place jack stands under the front of the front suspension crossmember, the transmission, and transfer case.
43. Route the transfer case harness across the tunnel and transfer case.
44. Connect the NOX sensor 1/1 electrical connector in the right front wheel opening.

**Service Procedure [Continued]**

45. Install the crossmember (1) and install the crossmember bolts (2) (Figure 33).
46. Tighten the crossmember bolts (2) to 48 N·m (35 ft. lbs.).
47. Remove the lift table.
48. Install the transmission mount nuts and tighten to 61 N·m (45 ft. lbs.) for 2wd, and 23 N·m (17 ft. lbs.) for 4wd.
49. Install the crossmember reinforcement brackets and tighten to 55 N·m (41 ft. lbs.).
50. Install the rear engine cradle crossmember stiffener brackets and tighten the bolts:
  - Rear engine cradle bolts to 175 N·m (129 ft. lbs.).
  - Six cradle stiffener bracket bolts to 20 N·m (15 ft. lbs.).
51. Remove the jack stands from the front of the front suspension crossmember, the transmission, and transfer case.
52. Connect the transfer case wire harness connector and attach wire harness retainers.

**NOTE: Clean all propeller shaft bolts and apply Mopar® Lock AND Seal Adhesive or equivalent to the threads before installation.**

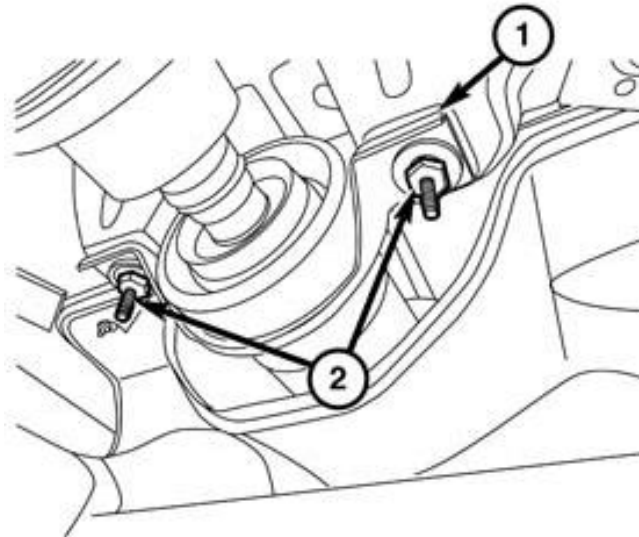
**CAUTION: Failure to follow these instructions may result in a driveline vibration.**

53. Install the rear driveshaft.
  - For Coupler type, install the propeller shaft on transfer case or transmission with reference marks, made during removal, are aligned. Install flange bolts and nuts and tighten to 85 N·m (63 ft. lbs.).
  - For Constant Velocity (CV) Joint type, install the propeller shaft on transfer case or transmission with the reference marks, made during removal, are aligned. Install the flange bolts and tighten in a star pattern to 55 N·m (41 ft. lbs.).

**Service Procedure [Continued]**

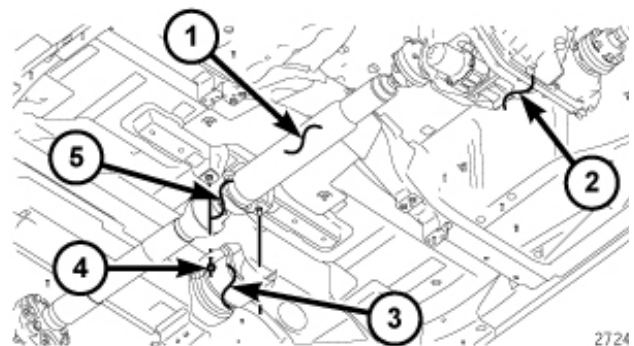
**CAUTION: Make sure the center bearing is installed in the correct orientation. Failure to do so can create a vibration while driving the vehicle and subsequent damage to the drivetrain components.**

54. Install the center bearing (1). Tighten to 45 N·m (33 ft. lbs.) (Figure 52).



**Figure 52 – Center Bearing**

55. Install the center bearing heat shield (3) (Figure 53).
56. Install the rear propeller shaft heat shield and securely tighten the fasteners.
57. Install the MPR cable into the bracket and lock into place (Figure 28).



**Figure 53 – Heat Shield**

58. Remove the zip tie (3) from the MPR lever (Figure 28).
59. Connect the MPR cable (1) to the MPR lever (2) (Figure 28).
60. Install fuel filter water/separator assembly and fasteners (Figure 29) and tighten the fasteners to 20 N·m (15 ft. lbs.).
61. Connect the EPS harness (Figure 26).

**Service Procedure [Continued]**

62. Clean the Selective Catalytic Reduction (SCR) and Diesel Particulate Filter (DPF) flanges.
63. Using a **NEW** gasket, install the SCR to the DPF and tighten the nuts to 32 N·m (24 ft. lbs.).
64. Connect the DPF thermocouple (Figure 24).
65. Tighten the thermocouple after the DPF (4/4) to 40 N·m (30 ft. lbs.) (Figure 24).
66. Install the DEF injector and **NEW** gasket and clamp to the SCR.
67. Install the lower air suspension compressor support and tighten the nuts to 24 N·m (18 ft. lbs.).
68. Partially lower the vehicle.
69. Install the **NEW** lower clevis bolts and **NEW** nuts (6) and tighten to 235 N·m (173 ft. lbs.) (Figure 23).
70. Support the outside of the lower control arms with a suitable holding fixture, and raise to position the upper ball joints into the knuckles.
71. With the holding fixture holding the suspension at normal ride height, install the **NEW** upper ball joint nuts and tighten to 95 N·m (70 ft. lbs.) (Figure 21).
72. Install a **NEW** upper sway bar link nut on each side, and tighten to 96 N·m (71 ft. lbs.).
73. Connect the left and right wheel speed sensor wire harness connectors.
74. Install the left and right brake caliper assemblies.

**CAUTION: Verify that the brake hose is not twisted or kinked before tightening bracket bolts.**

75. Install the caliper bracket bolts and tighten to 200 N·m (148 ft. lbs.).

**Service Procedure [Continued]**

76. Connect the three ABS wire retainers on each side (Figure 19).
77. Connect the ABS wire connectors on both sides of the vehicle (Figure 18).
78. Connect the ABS wire clip to the frame (Figure 17).
79. Lower the vehicle to a working height for the engine compartment.
80. Connect the low pressure fuel supply and return line quick connect fittings by the brake booster (Figure 16).
81. Connect the two hose heater hoses (Figure 15).
82. Lubricate the **NEW** seals with clean refrigerant oil and install them onto the refrigerant line fittings. Use only the specified seals as they are made of a special material for the refrigerant used in the system. Use only refrigerant oil of the type recommended for the A/C compressor in the vehicle.
83. Connect the A/C suction line and A/C discharge line to the A/C compressor and tighten the nuts to 20 N·m (15 ft. lbs.) (Figure 13).
84. Connect the steering shaft coupler to the steering shaft (3) and install a **NEW** pinch bolt (2) and tighten to 49 N·m (36 ft. lbs.) (Figure 14).
85. Connect the transmission cooler lines from the radiator.
86. Install the ground cable from the generator to the body and tighten the nut to 11 N·m (8 ft. lbs.).
87. Route the positive battery cable under the cowl extension, and fasten it to the jump start terminal. Tighten to 10 N·m (7 ft. lbs.)
88. Connect the positive battery cable to the fuse block. Tighten to 10 N·m (7 ft. lbs.)
89. Secure the relay and bracket assembly with two nuts to the strut tower (Figure 12).
90. Connect the electrical connector at the relay (Figure 11).



**Service Procedure [Continued]**

91. Connect the 16-pin connector at the strut tower (Figure 10).
92. Connect the harness from the PCM (Figure 9).
93. Connect the main wiring harness (Figure 8).
94. Install two bolts retaining the coolant reservoir to the body and tighten to 10 N·m (89 in. lbs.) (Figure 7).
95. Install the coolant return hose.
96. Install the upper and lower radiator hoses to the engine.
97. Install the vacuum booster hose at the vacuum pump.
98. Fill the cooling system and perform the Coolant System Air Evacuation procedure following your equipment manufacturers instructions.
99. Install the coolant recovery bottle pressure cap.
100. Connect the CAC hose (1) from the EGR air flow control valve (Figure 6).
101. Connect the resonator to turbocharger CAC hose.
102. Connect the MAF sensor connector, the air filter box and intake tube (Figure 5).
103. Attach weather strip seal at air inlet snorkel.
104. Install the engine cover (Figure 4).
105. Recharge the air conditioning system.
106. Raise and support the vehicle.
107. Install the front cover and tighten the front bolts (1) to 55 N·m (41 ft. lbs.) Leave the rear bolts (3) loose (Figure 3).

**Service Procedure [Continued]**

108. Install the front suspension skid plate (2). Tighten bolts (1) and (3) to 28 N·m (21 ft. lbs.) (Figure 2).
109. Install the transmission splash shield and tighten bolts to 28 N·m (21 ft. lbs.) (Figure 1).
110. Lower the vehicle to a working height to install the wheels and tires.
111. Install the wheels and tires. Torque the lug nuts to 176 N·m (130 ft. lbs.).
112. Connect the negative battery cable.
113. Start engine, allow to warm, turn engine off and inspect for leaks.
114. Check and top off fluids as needed.

## Service Procedure

### DS – Ram 1500 Pickup

This procedure is written for 4wd Ram 1500 Pickups. For 2wd vehicles, use the same steps without 4wd specific components.

#### A. Remove

1. Disconnect the negative battery cable.
2. Remove the bolts (1) and the vibration damper cover (2) (Figure 1).
3. For 4wd vehicles, make sure the transfer case is in 2wd.
4. Raise and support the vehicle.

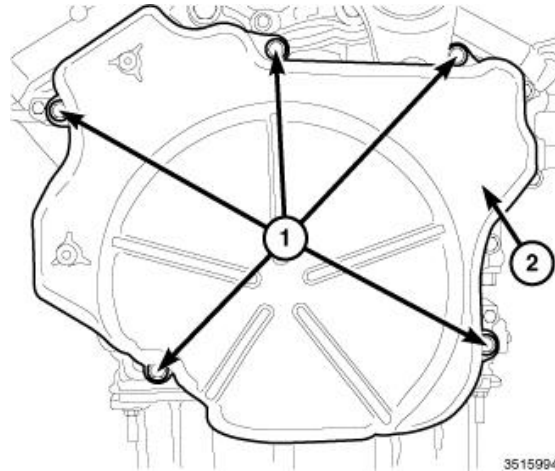


Figure 1 – Vibration Damper Cover

**NOTE:** When servicing the cooling system, it is essential that coolant does not drip onto the accessory drive belts and/or pulleys. Shield the belts with shop towels before working on the cooling system. If coolant contacts the belts or pulleys, flush both with clean water.

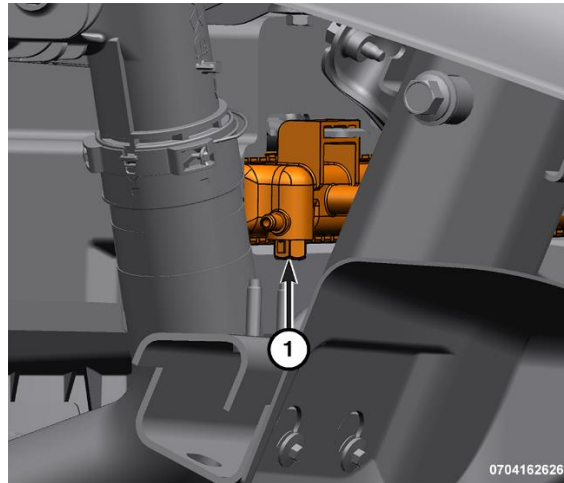
**WARNING:** Make sure engine cooling system is cool before servicing. Do not remove any clamps or hoses, pressure cap, or open the radiator draincock. When the system is hot and under pressure serious burns from coolant can occur.

**NOTE:** DO NOT WASTE reusable coolant. If the solution is clean, drain the coolant into a clean retainer for reuse.

5. Position a drain pan under the draincock location.

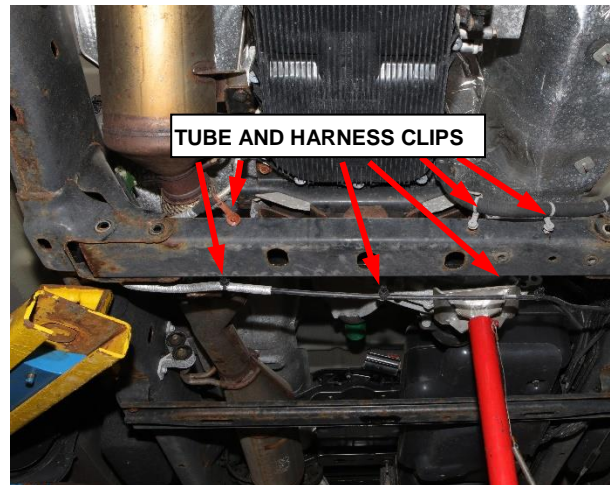
**Service Procedure [Continued]**

6. Open radiator draincock (1) located at the lower left side of radiator. Turn draincock counterclockwise until it stops and allow to drain (Figure 2).
7. Remove coolant pressure cap.
8. Remove the transfer case skid plate, if equipped.
9. Support transmission and transfer case with jack stands.



**Figure 2 – Radiator Draincock**

10. Release the push pin clips retaining the DEF tube and wiring harness to the transmission crossmember (Figure 3).

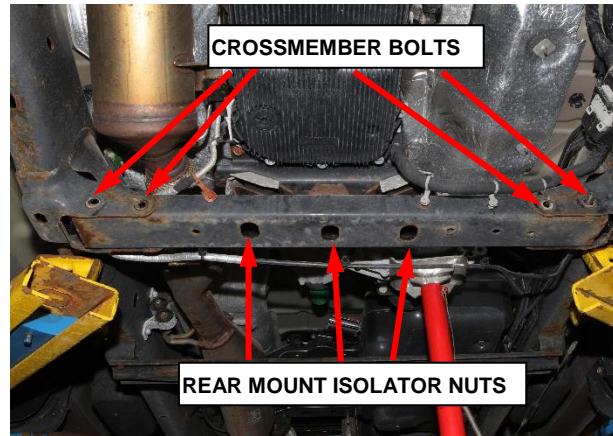


**Figure 3 – Transmission Crossmember**

11. Mark front and rear propeller shafts for alignment reference.
12. Remove front and rear propeller shafts.

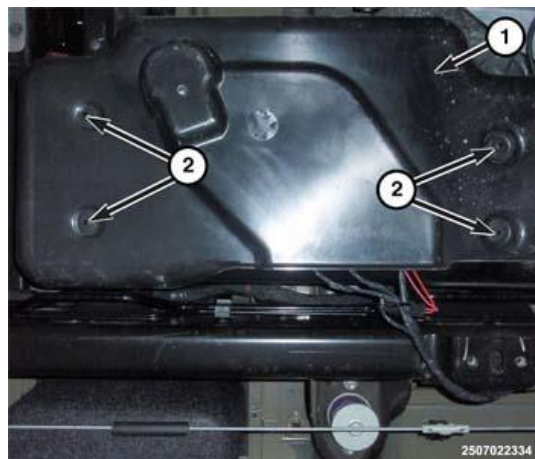
**Service Procedure [Continued]**

13. Remove rear mount isolator nuts, the crossmember bolts, and crossmember (Figure 4).



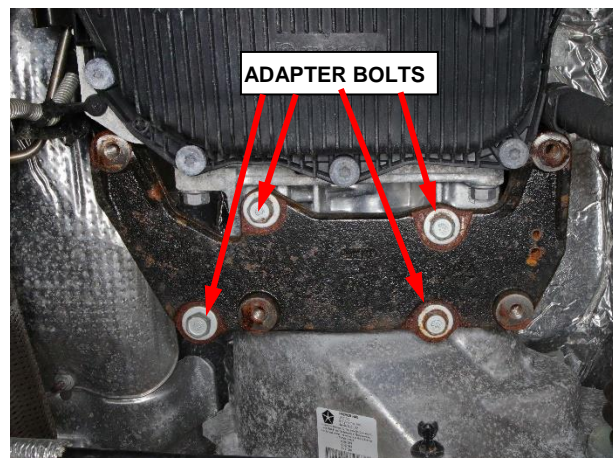
**Figure 4 – Transmission Crossmember**

14. Remove the four nuts (2) retaining the DEF tank shield (1) (Figure 5).
15. Remove the transmission skid plate crossmember from below the DEF tank.



**Figure 5 – DEF Tank Shield**

16. Remove the four bolts and the rear engine mount bracket (Figure 6).



**Figure 6 – Rear Engine Mount Bracket**

17. Disconnect transfer case shift motor and mode sensor wire connectors (3) and the transfer case wiring harness retainers (Figure 7).
18. Disconnect transfer case vent hose.

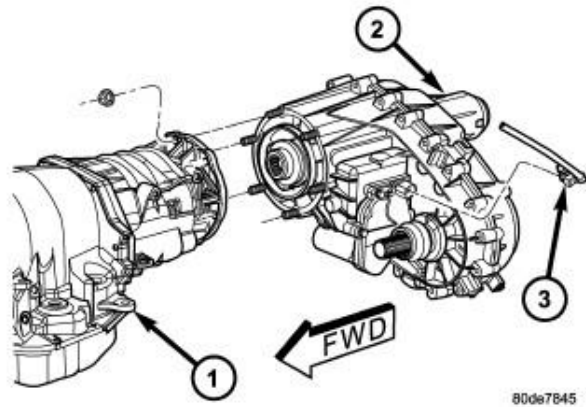


Figure 7 – Transfer Case

19. Remove damper weight from transfer case (Figure 8).
20. Support transfer case with transmission jack.
21. Secure transfer case to jack with chains.
22. Remove nuts attaching transfer case (2) to transmission (1) (Figure 7).



Figure 8 – Transfer Case Damper

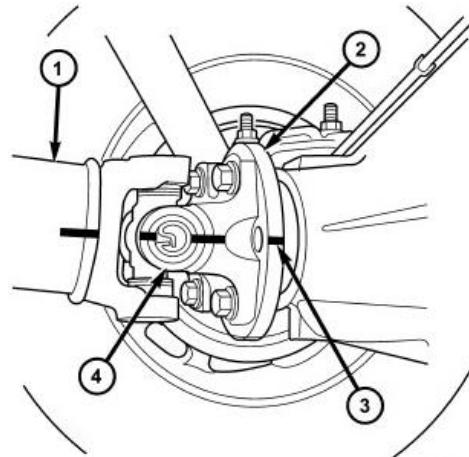
23. Pull transfer case and jack rearward to disengage transfer case.

**Service Procedure [Continued]**

24. Remove transfer case from under vehicle.

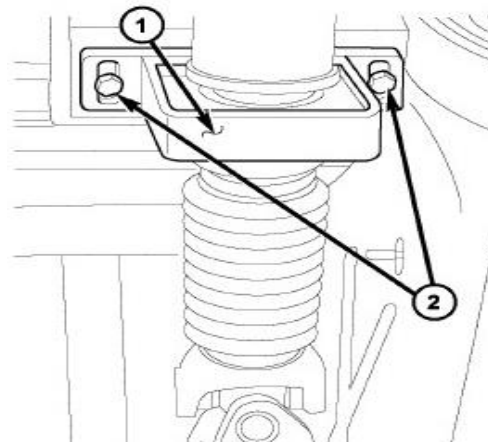
**CAUTION: Failure to follow these instructions may result in a driveline vibration.**

25. For 2wd, mark propeller shaft (1) pinion flange (2) and propeller shaft flange (4) with installation reference marks (3) (Figure 9).



**Figure 9 – Propeller Shaft Flange**

26. If equipped with a center bearing (1) mark an outline of the center bearing (1) on the center bearing bracket for installation reference. Then support propeller shaft and remove mounting bolts (2) (Figure 10).



**Figure 10 – Center Bearing**

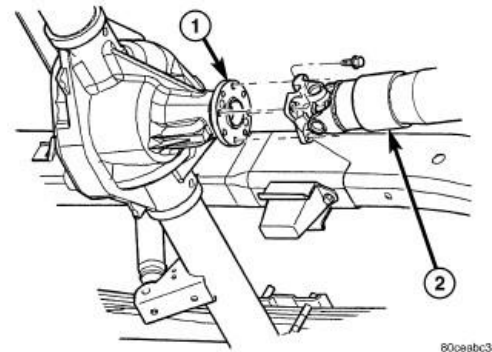
27. Using a long piece of wood or similar, fasten it to the propeller shaft with several cable ties in order to keep the propeller shaft from over-articulating during removal and installation (Figure 11).



**Figure 11 – Supporting Propeller Shaft**

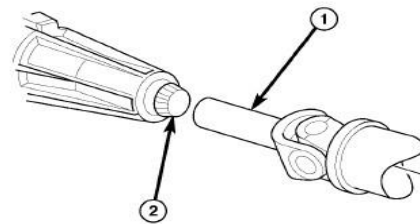
**Service Procedure [Continued]**

28. Remove pinion flange (1) bolts from propeller shaft (2) (Figure 12).



**Figure 12 – Pinion Flange**

29. Slide the propeller shaft back off of the automatic transmission output shaft, then mark propeller shaft (1) and transmission output shaft (2) for installation reference (Figure 13).



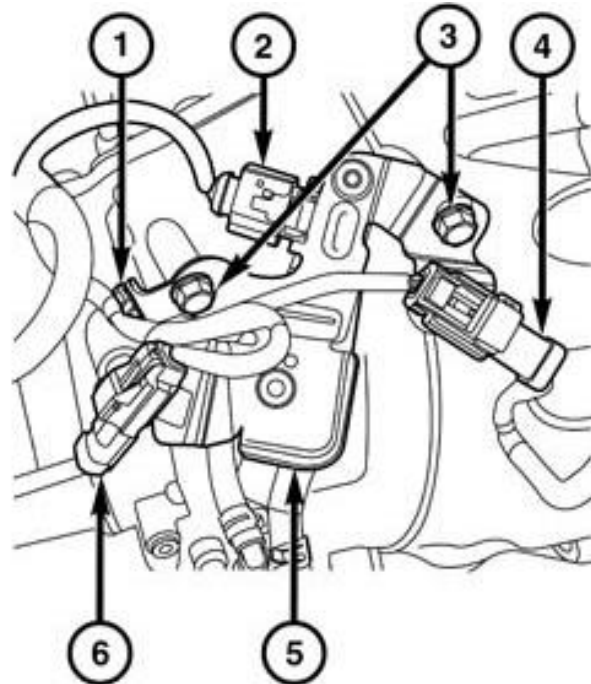
**Figure 13 – Transmission Output Shaft**

30. Remove the propeller shaft from the vehicle.
31. Remove the transmission and DEF injector wiring from the transmission case.
32. Remove the transmission vent hose from the transmission.



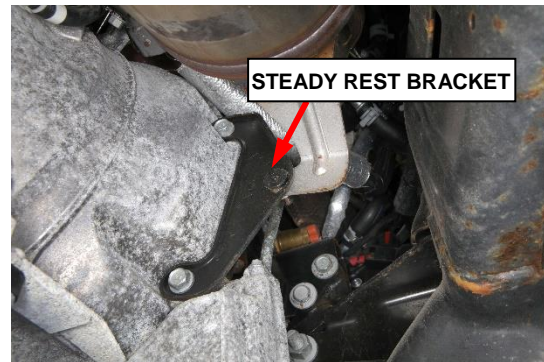
**Service Procedure [Continued]**

33. Remove two bolts (3) holding the DPF differential pressure sensor and bracket (5) to the transmission (Figure 14).



**Figure 14 – EGT/CEGT Sensor Connectors**

34. Remove the nut retaining the front DPF steady rest bracket to the transmission (Figure 15).



**Figure 15 – Front Steady Rest Bracket**

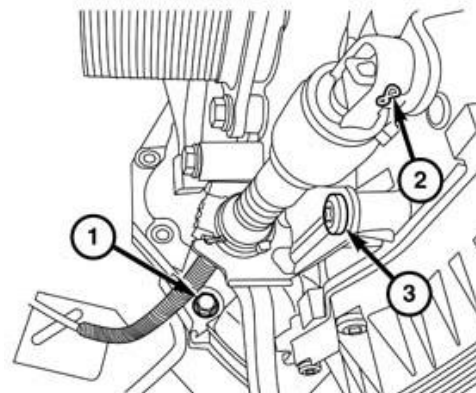
**Service Procedure [Continued]**

35. Remove the nut retaining the rear DPF steady rest bracket to the transmission (Figure 16).



**Figure 16 – Rear Steady Rest Bracket**

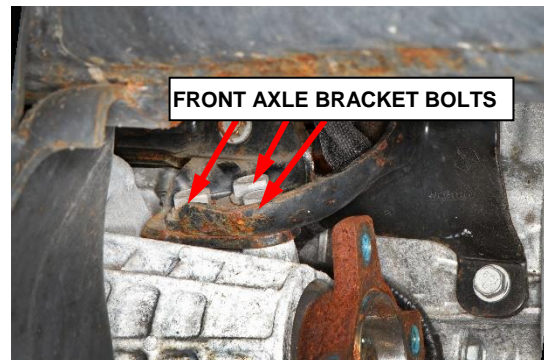
36. Detach the starter cable harness retainer.
37. Disconnect the manual park release cable (1) from the lever (2) (Figure 17).
38. Remove the bolts from the manual park release cable bracket (3) and set the bracket/cable (2, 3) aside (Figure 17).



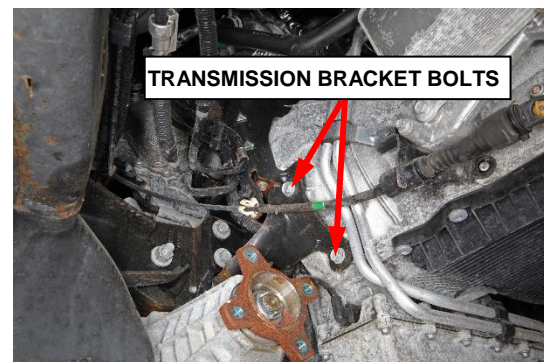
**Figure 17 – MPR Cable and Bracket**

**Service Procedure [Continued]**

39. Remove the five bolts retaining front axle pinion housing to transmission bracket. Note that the top bolt is longer as it passes through two brackets (Figures 18 and 19).

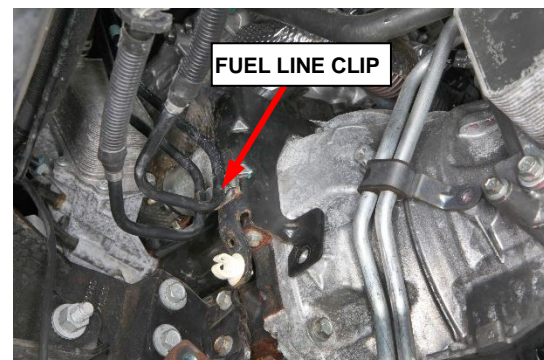


**Figure 18 – Bracket at Front Axle**



**Figure 19 – Bracket at Transmission**

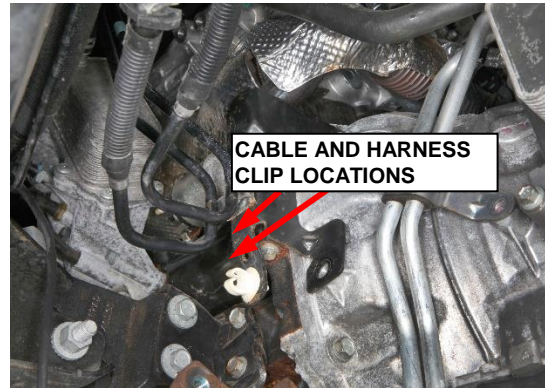
40. Release the fuel lines from the clip on the upper bracket (Figure 20).



**Figure 20 – Upper Bracket at Transmission**

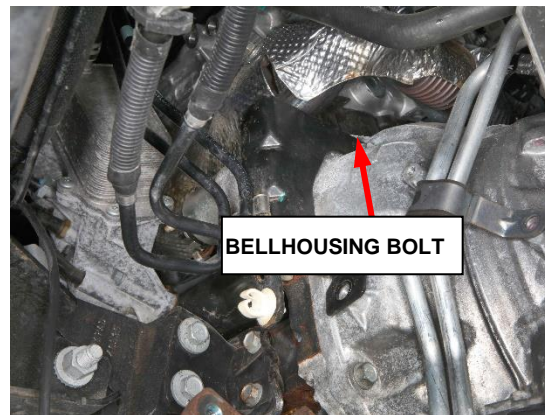
**Service Procedure [Continued]**

41. Release the MRP cable and wiring harnesses from the upper bracket (Figure 21).



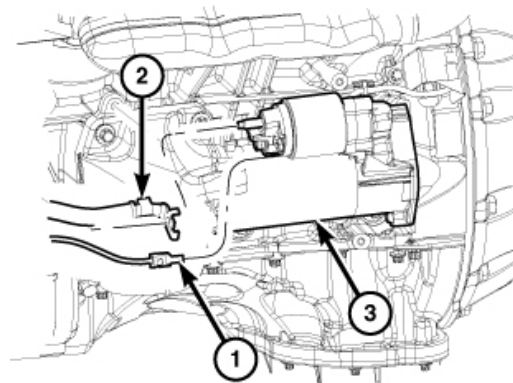
**Figure 21 – Cable and Harness Clip Locations**

42. Remove the bellhousing bolt retaining the upper bracket (Figure 22).



**Figure 22 – Upper Bracket**

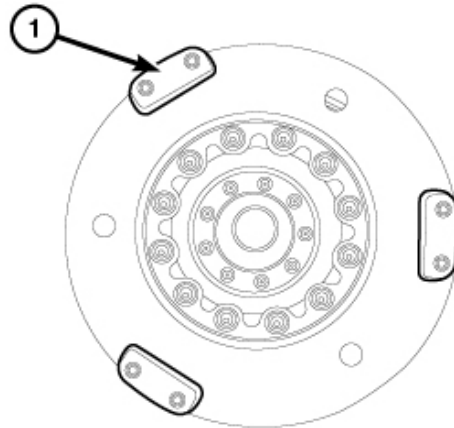
43. Disconnect the solenoid connector (1) (Figure 23).
44. Remove the B+ battery cable retainer and remove the B+ battery cable (2) (Figure 23).
45. Remove the retainers and remove the starter (3) (Figure 23).



**Figure 23 – Starter Motor Connections**

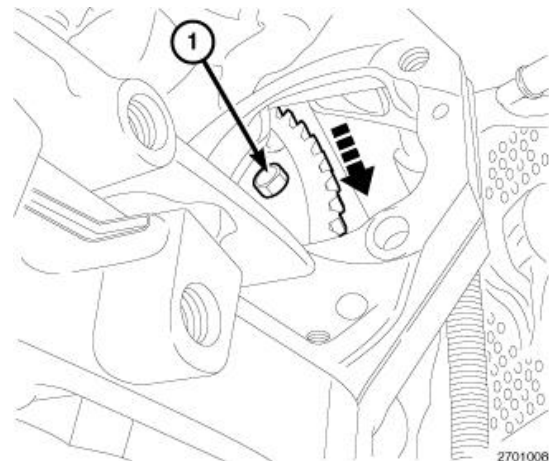
**Service Procedure [Continued]**

46. The torque converter is attached with three sets of two bolts (1) 120° apart as shown (Figure 24).



**Figure 24 – Torque Converter Bolt Pattern**

47. Rotate the crankshaft in a clockwise direction for access, and through the starter opening, remove the six torque converter bolts (1) (Figure 25).



**Figure 25 – Torque Converter Bolt**

48. Remove the transmission oil cooler tube support bracket and nut.

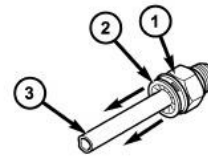
**CAUTION: When supporting or lifting the transmission at the oil pan the weight of the transmission must be distributed evenly on the lifting fixture. Failure to do so could damage the oil pan and transmission.**

49. Position a transmission jack under the transmission and secure the transmission with chains or straps.

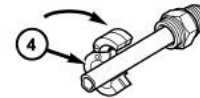
**Service Procedure [Continued]**

- 50. Remove the transmission bellhousing fasteners.
- 51. Remove the coolant hoses at heat exchanger.
- 52. Remove dust cap by pulling it straight back off of quick connect fitting.

53. Place disconnect Special Tool 8875A onto a  $\frac{3}{8}$  inch transmission cooler lines or Special Tool 9546 onto a  $\frac{1}{2}$  inch transmission cooler lines with the fingers of the tool facing the quick connect fitting (Figure 26).



54. Slide disconnect tool down the transmission line and engage the fingers of the tool into the retaining clip. When properly engaged in the clip, the tool will fit flush against the quick connect fitting (Figure 26).



55. Rotate the disconnect tool 60° to expand the retaining clip (Figure 26).



56. While holding the disconnect tool against the quick connect fitting, pull back on the transmission cooler line to remove (Figure 26).

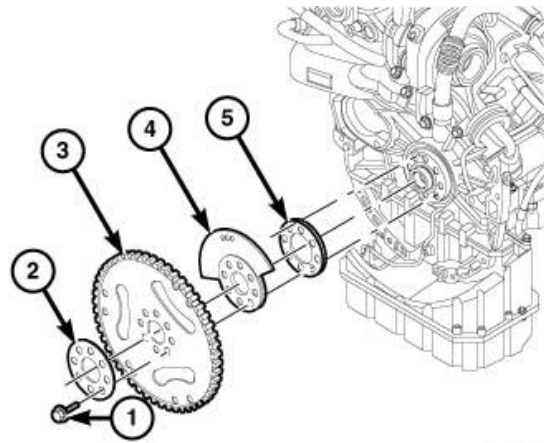
**Figure 26 – Quick Connect Fittings**

- 57. Hold the torque converter in place during transmission removal.
- 58. Remove the transmission assembly from the vehicle.
- 59. Paint mark the flexplate hub to flexplate relationship.

**Service Procedure [Continued]**

**CAUTION:** Do not use an impact socket or a thick walled socket when removing or installing the flexplate retaining bolts, damage to the crankshaft, internal engine or the transmission may occur.

60. Remove the bolts (1) and flex plate (3) (Figure 27).
61. Remove the counter weight (4) and tone wheel (5) (Figure 27).
62. Inspect the crankshaft position sensor for damage, and replace as needed.



3127573  
Figure 27 – Tone Wheel Removal

**B. Install**

1. Install the **NEW** tone wheel 68493358AA (5) (Figure 27).

**NOTE:** Make sure the dowel pin (1) is installed in the dead hole of the counter weight. The other hole is a through hole and is not to be used (Figure 28).

**NOTE:** Do Not lubricate the **NEW** bolts as they are already coated with an anti-scuff treatment.

**NOTE:** Always use **NEW** flexplate bolts whenever the existing bolts have been removed.



0911096445  
Figure 28 – Counter Weight Dowel Pin

**Service Procedure [Continued]**

2. Install the counter weight (4) and make sure the dowel pin side is inserted into the crankshaft hole for proper counter weight timing. A vibration can occur if the counter weight is installed incorrectly (Figure 27).
3. Install the flexplate, aligning the paint marks.

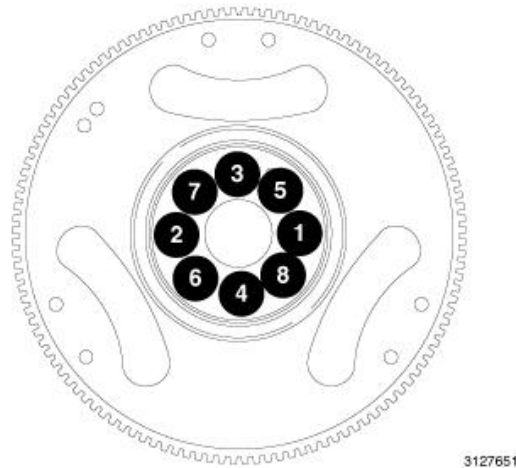
**NOTE: With clean engine oil, lubricate the bolt side of backing plate (2).**

4. Lubricate and install the backing plate (2) and tighten the **NEW** bolts 68161231AA (1) finger tight (Figure 27).

**CAUTION: Do not use an impact socket or a thick walled socket when removing or installing the flexplate retaining bolts, damage to the crankshaft, internal engine or the transmission may occur.**

5. Using the tightening sequence shown in Figure 29, tighten bolts to:

- Tighten the bolts 50 N·m (37 ft. lbs.).
- Loosen one bolt at a time and then retighten the bolt in a clockwise cross pattern to 125 N·m (92 ft. lbs.).
- Using a torque angle gauge, tighten each bolt an additional 30 degrees in a clockwise cross pattern.



**Figure 29 – Flexplate Tightening Sequence**

6. Lubricate the nose of the torque converter, and install the transmission to the engine. Install bellhousing bolts finger tight.

**NOTE: Make sure that the transmission dowel pins are seated in engine block and protrude far enough to hold transmission in alignment.**

7. Hold the torque converter in place during transmission installation.



<b>Service Procedure [Continued]</b>
--------------------------------------

8. Align transmission cooler line with quick connect fitting while pushing straight into the fitting (Figure 30).

9. Push in on transmission cooler line until a “click” is heard or felt (Figure 30).

10. Push in on transmission cooler line until a “click” is heard or felt.

**NOTE: If dust cap will not snap into place, repeat assembly step 2.**

11. Verify that the torque converter spins, and is not bound up.

12. Align torque converter to flywheel holes.

13. Verify that the torque converter is pulled flush to the flexplate.

14. Install the torque converter bolts and tighten to 42 N·m (31 ft. lbs.).

15. Tighten the bellhousing bolts to 50 N·m (37 ft. lbs.). Install the upper bracket on the driver side and the upper DPF bracket by their shared bellhousing bolt at this time.

16. Install the coolant hoses at heat exchanger.

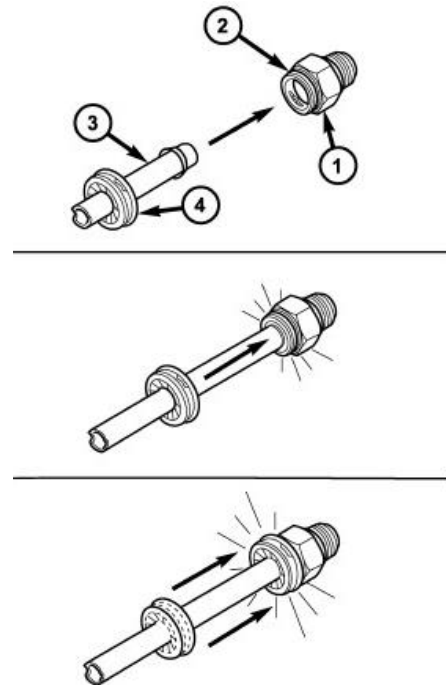
17. Install the transmission oil cooler tube support bracket and nut.

18. Install the bolts (1) and the vibration damper cover (2) (Figure 1).

19. Install the starter (3) the battery cable retainers. Tighten the starter bolts to 54 N·m (40 ft. lbs.) (Figure 23).

20. Install the B+ battery cable retainer and install the B+ battery cable nut to 12 N·m (9 ft. lbs.) (2) (Figure 23).

21. Connect the solenoid connector (1) (Figure 23).



**Figure 30 – Quick Connect Fittings**

**Service Procedure [Continued]**

22. Install the MRP cable and wiring harnesses to the upper bracket (Figure 21).
23. Install the fuel lines to the clip on the upper bracket (Figure 20).
24. Install the five bolts retaining front axle pinion housing to transmission bracket. Tighten bolts to 110 N·m (81 ft. lbs.) (Figures 18 and 19).
25. Install the bolts to the manual park release cable bracket (3) and tighten to 20 N·m (15 ft. lbs.) (Figure 17).
26. Install the manual park release cable (1) to the lever (2) (Figure 17).
27. Install the starter cable harness retainer.
28. Install the nut retaining the rear DPF steady rest bracket to the transmission and tighten to 32 N·m (24 ft. lbs.) (Figure 16).
29. Install the nut retaining the front DPF steady rest bracket to the transmission and tighten to 32 N·m (24 ft. lbs.) (Figure 15).
30. Install two bolts (3) holding the DPF differential pressure sensor and bracket (5) to the transmission and tighten to 21 N·m (15 ft. lbs.) (Figure 14).
31. Install wiring connections at the differential pressure sensor.
32. Install the transmission vent hose to the transmission.
33. Install the transmission and DEF injector wiring to the transmission case.
34. Install the transfer case to a jack and move it into place behind the transmission.
35. Push the transfer case and jack forward to engage transfer case.
36. Install nuts attaching transfer case (2) to transmission (1) and tighten to 27 N·m (20 ft. lbs.) (Figure 7).
37. Install the damper weight from transfer case and tighten to 55 N·m (41 ft. lbs.) (Figure 8).

**Service Procedure [Continued]**

38. Install the transfer case vent hose.
39. Install the transfer case shift motor and mode sensor wire connectors (3) and the transfer case wiring harness retainers (Figure 7).
40. Install the four bolts and the rear engine mount bracket and tighten to 33 N·m (24 ft. lbs.) (Figure 6).
41. For 2wd vehicle, install the propeller shaft.
42. Slide the propeller shaft onto the automatic transmission output shaft, noting the alignment marks made during removal (Figure 13).

**NOTE: Drive shaft bolts must be replaced or cleaned and Mopar® Lock and Seal Adhesive or equivalent applied.**

43. Install the pinion flange (1) bolts to propeller shaft (2) and tighten to 115 N·m (85 ft. lbs.) (Figure 12).
44. Remove the piece of wood used to keep the propeller shaft from over-articulating during removal and installation (Figure 11).
45. If equipped with a center bearing, align it with the outline of the center bearing (1) on the center bearing bracket made during removal (Figure 10).
46. Install the mounting bolts (2) and tighten to 54 N·m (40 ft. lbs.).
47. For 4wd, install the rear propeller shaft to the splined output shaft of the transfer case.
48. Install the rear of the propeller shaft to the pinion flange, aligning the marks made during removal. Tighten the flange bolts to 115 N·m (85 ft. lbs.).
49. Install the front propeller shaft to the splined output shaft of the transfer case.
50. Install the front of the propeller shaft to the front axle pinion flange, aligning the marks made during removal. Tighten the flange bolts to 115 N·m (85 ft. lbs.).

**Service Procedure [Continued]**

51. Install the four nuts (2) retaining the DEF tank shield (1) and tighten to 15 N·m (11 ft. lbs.) (Figure 5).
52. Install rear engine mount isolator nuts, and crossmember bolts. Tighten bolts to 107 N·m (80 ft. lbs.) and the nuts to 61 N·m (45 ft. lbs.) (Figure 4).
53. Install skid plate crossmember below DEF tank. Tighten the crossmember bolts to 18 N·m (13 ft. lbs.).
54. Secure the DEF tube, transmission and transfer case harnesses to the transmission crossmember.
55. Remove the support jacks.
56. Install the transfer case skid plate, if equipped. Tighten the bolts to 18 N·m (13 ft. lbs.).
57. Connect the negative battery cable.
58. Refill the cooling system. Perform the Standard Procedure - Coolant Fill.
59. Perform the Standard Procedure – Transmission Fill After Service.
60. If transfer case fluid was lost during removal and installation, check the fluid level and top off as needed.

**Complete Proof of Correction Form for California Residents**

This recall is subject to the **State of California Registration Renewal/Emissions Recall Enforcement Program**. Complete a Vehicle Emission Recall Proof of Correction Form (**Form No. 81-016-1053**) and **supply it to vehicle owners residing in the state of California** for proof that this recall has been performed when they renew the vehicle registration.

Process Steps to obtain the California Proof of Correction form:

- a. Access the “**DealerCONNECT**” website.
- b. Select the “**Service**” tab.
- c. Under the “**Publications**” heading, select the “**ePublishing**” link.
- d. Sign in using your **Dealer Code** and **Password**.
- e. Select the “**Proof of Correction form**”.

**Completion Reporting and Reimbursement**

Claims for vehicles that have been serviced must be submitted on the DealerCONNECT Claim Entry Screen located on the Service tab. Claims paid will be used by FCA to record recall service completions and provide dealer payments.

Use the following labor operation numbers and time allowances:

	<b>Labor Operation Number</b>	<b>Time Allowance</b>
Replace Crankshaft Tone Wheel (2014-2016 DS Models Only)	09-W6-81-82	3.9 hours
Replace Crankshaft Tone Wheel (2014-2016 WK Models Only)	09-W6-81-83	7.5 hours

**Optional Equipment**

4x4 Equipped (2014-2016 DS Models Only)	09-W6-81-60	1.1 hours
4x4 Equipped (2014-2016 WK Models Only)	09-W6-81-60	0.5 hours
Skid Plate Equipped (2014-2016 DS Models Only)	09-W6-81-61	0.1 hours
Skid Plate Equipped (2014-2016 WK Models Only)	09-W6-81-61	0.2 hours

Add the cost of the parts plus applicable dealer allowance to your claim. In addition, enter “MATL” in the Part Number section of your claim with the applicable Material Allowance where appropriate.

**NOTE: See the Warranty Administration Manual, Recall Claim Processing Section, for complete recall claim processing instructions.**

## Dealer Notification

To view this notification on DealerCONNECT, select “Global Recall System” on the Service tab, then click on the description of this notification.

## Owner Notification and Service Scheduling

All involved vehicle owners known to FCA are being notified of the service requirement by first class mail. They are requested to schedule appointments for this service with their dealers. A generic copy of the owner letter is attached.

## Vehicle Lists, Global Recall System, VIP and Dealer Follow Up

All involved vehicles have been entered into the DealerCONNECT Global Recall System (GRS) and Vehicle Information Plus (VIP) for dealer inquiry as needed.

GRS provides involved dealers with an updated VIN list of their incomplete vehicles. The owner’s name, address and phone number are listed if known. Completed vehicles are removed from GRS within several days of repair claim submission.

To use this system, click on the “**Service**” tab and then click on “**Global Recall System.**” Your dealer’s VIN list for each recall displayed can be sorted by: those vehicles that were unsold at recall launch, those with a phone number, city, zip code, or VIN sequence.

**Dealers must perform this repair on all unsold vehicles before retail delivery.** Dealers should also use the VIN list to follow up with all owners to schedule appointments for this repair.

*Recall VIN lists may contain confidential, restricted owner name and address information that was obtained from the Department of Motor Vehicles of various states. Use of this information is permitted for this recall only and is strictly prohibited from all other use.*

**Additional Information**

If you have any questions or need assistance in completing this action, please contact your Service and Parts District Manager.

Customer Services / Field Operations  
FCA US LLC



This notice applies to your vehicle,

[Model Year and Model]

VIN XXXXXXXXXXXXXXXXXXXX

W68/NHTSA 20V-475

LOGO

VEHICLE PICTURE

#### YOUR SCHEDULING OPTIONS

- 1. RECOMMENDED OPTION**  
Call your authorized Chrysler / Dodge / Jeep® / RAM dealership
- 2. Call the FCA Recall Assistance Center at 1-800-853-1403. An agent can confirm part availability and help schedule an appointment**
- 3. Visit recalls.mopar.com, scan the QR code below, or download the Mopar Owner's Companion App.**

QR Code

Get access to recall notifications, locate your nearest dealer, and more through this website or Mopar Owner's Companion App. You will be asked to provide your Vehicle Identification Number (VIN) to protect and verify your identity. The last eight characters of your VIN are provided above.

#### DEALERSHIP INSTRUCTIONS

Please reference Safety Recall W68.

# IMPORTANT SAFETY RECALL

## Loss of Crankshaft Position

Dear [Name],

This notice is sent to you in accordance with the National Traffic and Motor Vehicle Safety Act.

FCA US has decided that a defect, which relates to motor vehicle safety, exists in certain [2014 through 2016 Model Year (DS) Ram 1500 Pickup and 2014 through 2016 Model Year (WK) Jeep® Grand Cherokee] vehicles.

It is extremely important to take steps now to repair your vehicle to ensure the safety of you and your passengers.

#### WHY DOES MY VEHICLE NEED REPAIRS?

The magnetic material attached to the tone wheel on your vehicle <sup>[1]</sup> provides a signal to the crankshaft position sensor. If this signal material is lost, the engine loses its ability to synchronize injector pulses and cam timing. This loss of crankshaft position can result in an engine stall, as well as loss of the ability to restart the engine. **A loss of motive power can cause a vehicle crash without prior warning.**

#### HOW DO I RESOLVE THIS IMPORTANT SAFETY ISSUE?

FCA US will repair your vehicle <sup>[2]</sup> free of charge (parts and labor). To do this, your dealer will replace the tone wheel. The estimated repair time is 8 hours depending on vehicle configuration. In addition, your dealer will require your vehicle for proper check-in, preparation, and check-out during your visit, which may require more time. Your time is important to us, so we recommend that you schedule a service appointment to minimize your inconvenience. Please bring this letter with you to your dealership.

**TO SCHEDULE YOUR FREE REPAIR,  
CALL YOUR CHRYSLER, DODGE, JEEP OR RAM DEALER TODAY**

#### CALIFORNIA RESIDENTS

The State of California requires the completion of emission recall repairs prior to vehicle registration renewal. Your dealer will provide you with a Vehicle Emission Recall Proof of Correction Form after the Emission Recall service is performed. Be sure to save this form since the California Department of Motor Vehicles may require that you supply it as proof that the Emission Recall has been performed.

In order to ensure your full protection under the emissions warranty provisions, it is recommended that you have your (vehicle or engine) serviced as soon as possible. Failure to do so could be determined as lack of proper maintenance of your (vehicle or engine).

#### WHAT IF I ALREADY PAID TO HAVE THIS REPAIR COMPLETED?

If you have already experienced this specific condition and have paid to have it repaired, you may visit [www.fcarecallreimbursement.com](http://www.fcarecallreimbursement.com) to submit your reimbursement request online. <sup>[3]</sup> Once we receive and verify the required documents, reimbursement will be sent to you within 60 days. If you have had previous repairs performed and/or already received reimbursement, you may still need to have the recall repair performed.

We apologize for any inconvenience, but are sincerely concerned about your safety. Thank you for your attention to this important matter.

Customer Assistance/Field Operations  
FCA US LLC



**Mr. Mrs. Customer**  
**1234 Main Street**  
**Hometown, MI 48371**

[1] If you no longer own this vehicle, please help us update our records. Call the FCA Recall Assistance Center at 1-800-853-1403 to update your information.

[2] If your dealer fails or is unable to remedy this defect without charge and within a reasonable time, you may submit a written complaint to the Administrator, National Highway Traffic Safety Administration, 1200 New Jersey Ave., S.E., Washington, DC 20590, or you can call the toll-free Vehicle Safety Hotline at 1-888-327-4236 (TTY 1-800-424-9153), or go to [safercar.gov](http://safercar.gov).

[3] You can also mail in your original receipts and proof of payment to the following address for reimbursement consideration: FCA Customer Assistance, P.O. Box 21-8004, Auburn Hills, MI 48321-8007, Attention: Recall Reimbursement.

Note to lessors receiving this recall notice: Federal regulation requires that you forward this recall notice to the lessee within 10 days.