



Safety Recall Action Notice 582 Issue 1 - 08.2020

Subject: Rear Reflector				
Bulletin Number	Models Affected	VIN Range		Markets Affected
582	Tiger 900	From 978905	to AA9677	All Markets Except Brazil and China
	Tiger 900 GT			
	Tiger 900 GT Pro			
	Tiger Rally			
	Tiger Rally Pro			
	Tiger 900 GT Low Ride Height (LRH)			

Background Information

Internal investigations have identified the need to replace the rear reflector with a new reflector with larger spigots.

Dealers are requested to replace the rear reflector as described in the procedure below.

Customer Contact Instructions

Notice

STOP DELIVERY OF AFFECTED MOTORCYCLES IMMEDIATELY.

DO NOT deliver a motorcycle affected by this Safety Recall Action Notice to a customer until you have completed, or confirmed completion of, the procedures described in this Safety Recall Action Notice.

Delivering a motorcycle subject to an outstanding Safety Recall Action Notice may contravene local or national laws in your market, territory or country.

Triumph subsidiaries and distributors must instigate a Safety Recall Action in their country in accordance with the national recall code of practice. For vehicles in dealer stock, the safety recall MUST be actioned before delivery to the customer.

Dealers are to prioritise repair of customer owned motorcycles before any unsold motorcycles.

Identification of Affected Motorcycles

Tiger 900, Tiger 900 GT, Tiger 900 GT Pro, Tiger 900 Rally, Tiger 900 Rally Pro and Tiger 900 GT Low Ride Height (LRH).

Warranty Claim Instructions

Bulletin Number	Fault Code	Repair Code	Description	Repair Allowance	Time
582	02705091	99582	Remove and replace the rear reflector	0.1	

Genuine Parts Information

Bulletin Number	Part Number	Description	Quantity
582	T2706969	Rear Reflector Kit Kit contents: <ul style="list-style-type: none">• Rear Reflector x 1• Star Washer x 2• O-ring x 2	1

Parts Ordering Instructions

For Triumph Subsidiary and Overseas Distributor dealers using Triumph Warranty On-Line with Parts Auto Ordering Flag switched on: Order all repair parts by submitting a New Prior through the Warranty On-Line system. Entering the above repair code in a New Prior will automatically add the parts required and labour times for this Service Bulletin.

For Overseas Distributor dealers NOT using Triumph Warranty On-Line or for Overseas Distributor dealers using Triumph Warranty On-Line with Parts Auto Ordering Flag switched off: Orders should be placed using the normal parts ordering procedure.

Genuine Parts Return

Dealer to retain parts for 90 days. All parts must be stored in a secure, non-public accessed area and correctly identified with a completed warranty label. Thereafter the parts must be rendered unusable prior to scrapping.

Other Instructions

Once completed, please mark the Service Record Book that the requirements of this Safety Recall Action Notice have been complied with.

Before returning the motorcycle to the customer, download the latest calibration to the engine control module using the current version of the Triumph diagnostic software.

Removal

Warning

Make sure the motorcycle is stabilised and adequately supported.
A correctly supported motorcycle will help prevent it from falling.
An unstable motorcycle may fall, causing injury to the operator or damage to the motorcycle.

1. Remove the star washers and O-rings.
2. Remove the rear reflector from its bracket.

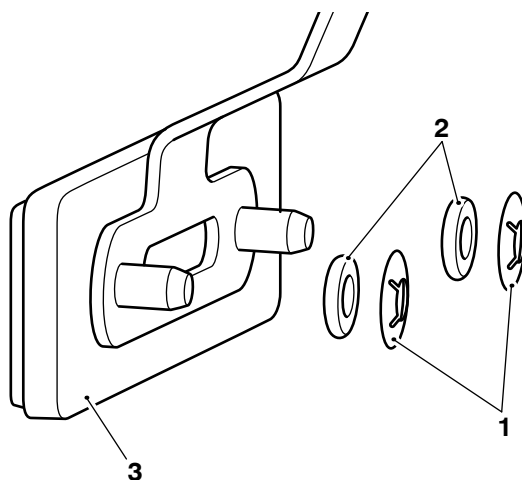

1. **Star washers**
2. **O-rings**
3. **Rear reflector**

Installation

1. From the kit, fit the new reflector to the bracket.
2. Fit the two new O-rings and the new star washers.

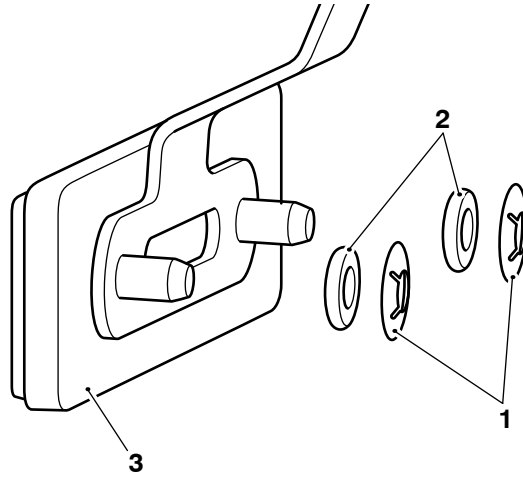

- 1. Star washers**
- 2. O-rings**
- 3. Rear reflector**

3. Check the reflector is secure, rectify if necessary.

Circulation

Initial and date when read and return to central file holder

Service Manager	Parts Manager	Sales Manager	Workshop Supervisor	Technician 1	Technician 2