

September 28, 2020

Version 3

Safety Recall: 2018 – 20 Odyssey Sliding Door Outer Handle CablesSupersedes 20-024, dated August 28, 2020, to revise the information highlighted in **yellow**.**AFFECTED VEHICLES**

Year	Model	Trim Level	VIN Range
2018 – 20	Odyssey	ALL	Check the iN VIN status for eligibility

REVISION SUMMARY

- Under **WARRANTY CLAIM INFORMATION**, a note was added.
- Under **REPAIR PROCEDURE**, steps were revised.

BACKGROUND

Water passing the sliding door outer handles, can enter the door outer handle cables assembly due to poor sealing properties. During freezing temperature conditions the water inside the cable assemblies will freeze. This condition causes additional friction and increases the risk of the door latching mechanism from closing completely, leading to an unsafe condition during vehicle operation.

CUSTOMER NOTIFICATION

Owners of affected vehicles will be sent a notification of this campaign.

Do an iN VIN status inquiry to make sure the vehicle is shown as eligible.

Some vehicles affected by this campaign may be in your new or used vehicle inventory.

Failure to repair a vehicle subject to a recall or campaign may subject your dealership to claims or lawsuits from the customer or anyone else harmed as a result of such failure. Before selling a vehicle in inventory, always check if it is affected by a safety recall by conducting a VIN status inquiry.

CORRECTIVE ACTION

Replace the left and right sliding door exterior door handle cables and bush joints.

CUSTOMER INFORMATION: The information in this bulletin is intended for use only by skilled technicians who have the proper tools, equipment, and training to correctly and safely maintain your vehicle. These procedures should not be attempted by "do-it-yourselfers," and you should not assume this bulletin applies to your vehicle, or that your vehicle has the condition described. To determine whether this information applies, contact an authorized Honda automobile dealer.

PARTS INFORMATION

Part Name	Part Number	Quantity
Sliding Door Outer Handle Cable Kit (includes right and left side)	06721-THR-308	1

NOTE

It is important to install the correct kit for the side you are working on.

RIGHT CABLE AND BUSH JOINT

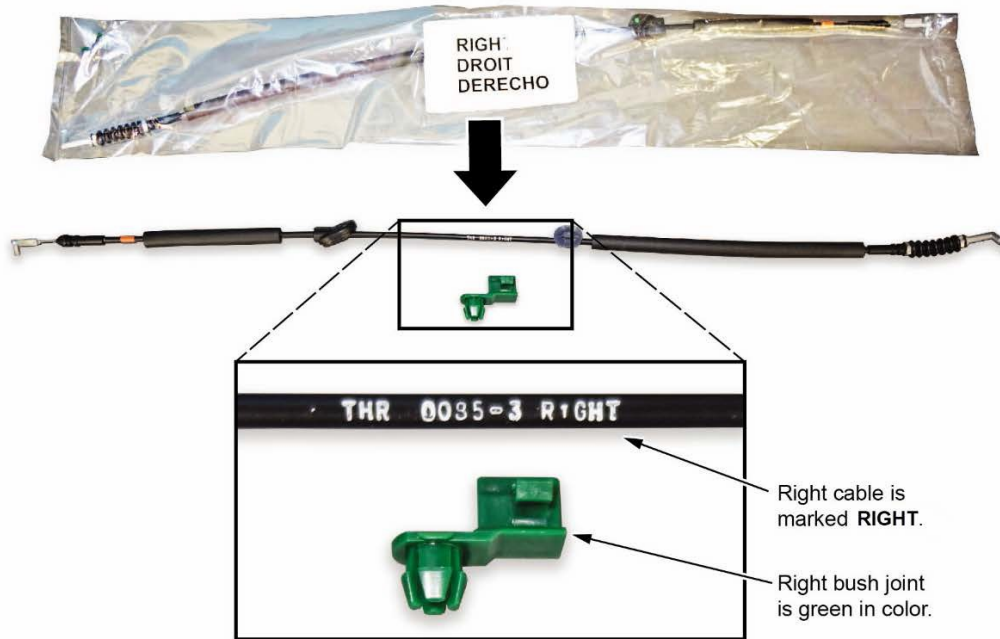

LEFT CABLE AND BUSH JOINT

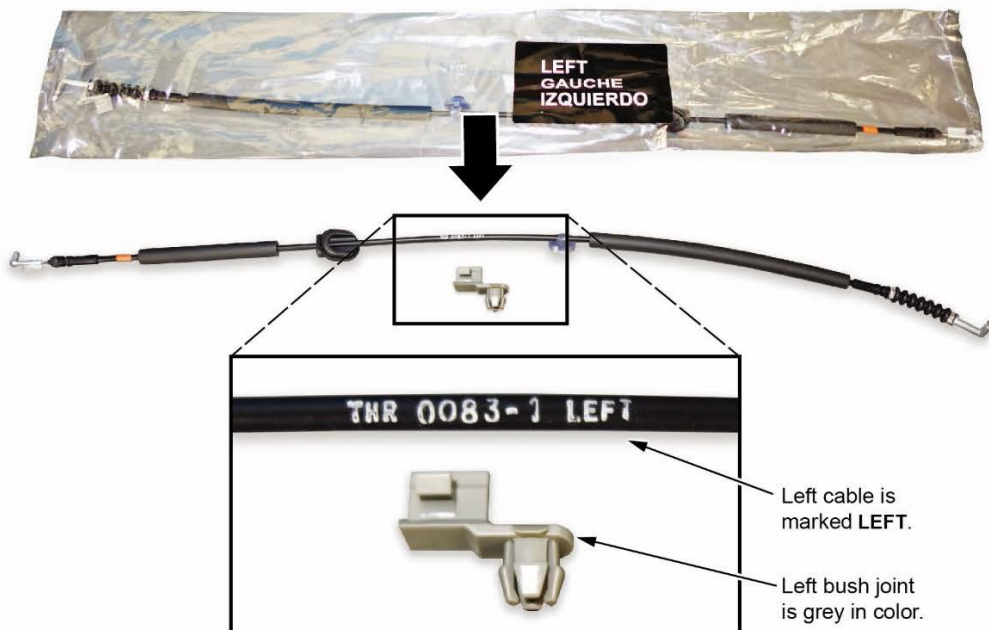

WARRANTY CLAIM INFORMATION

NOTE

If the RO was opened before 08/28/2020, use template A20024A. If it was opened on or after the date, use the template information below.

Operation Number	Description	Flat Rate Time	Defect Code	Symptom Code	Template ID	Failed Part Number
8181E5	Replace the left and right power sliding door outer handle cables and bush	1.2 hr	6PF00	A8800	A20024B	72681-THR-A01

Skill Level: Repair Technician

REPAIR PROCEDURE

The images in this repair procedure show the left side of the vehicle. The right side is a mirror image of these images.

1. Remove the second row outer seats.

NOTE

Remove any child or booster seats that are installed in the second row seats, and place them in the cargo area for the customer to install.

2. Confirm both sliding door windows are raised to the fully closed position.
3. Remove the air intake duct.

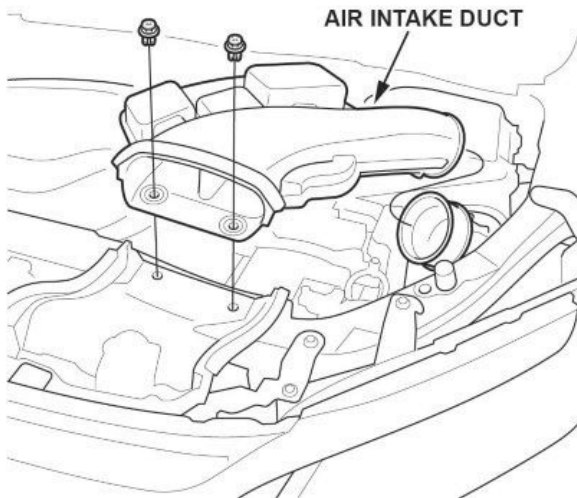

4. Disconnect the 12-volt battery.

NOTES

- Always disconnect the negative terminal first.

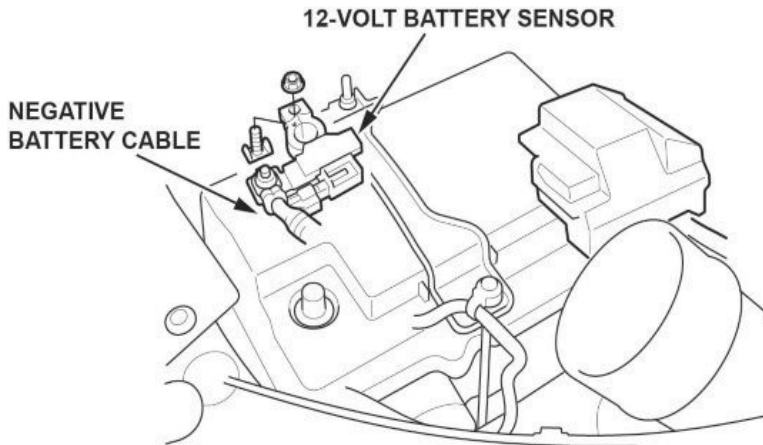

- To protect the battery sensor connector from damage, do not hold it when removing the terminal.
- Do not disconnect the 12-volt battery sensor from the cable.
 - 4.1. Make sure the ignition is turned to OFF.
 - 4.2. Disconnect and isolate the negative cable with the 12-volt battery sensor from the 12-volt battery.
 - 4.3. Disconnect and isolate the positive cable from the 12-volt battery.

5. Using a wire hook, pull the clip off of the inner handle shaft and remove the inner handle. **Make sure to cover the bottom part of the inner handle with a clean shop towel to capture the clip.**

NOTE

If you do not have a clean shop towel under the inner handle, you risk losing the clip.

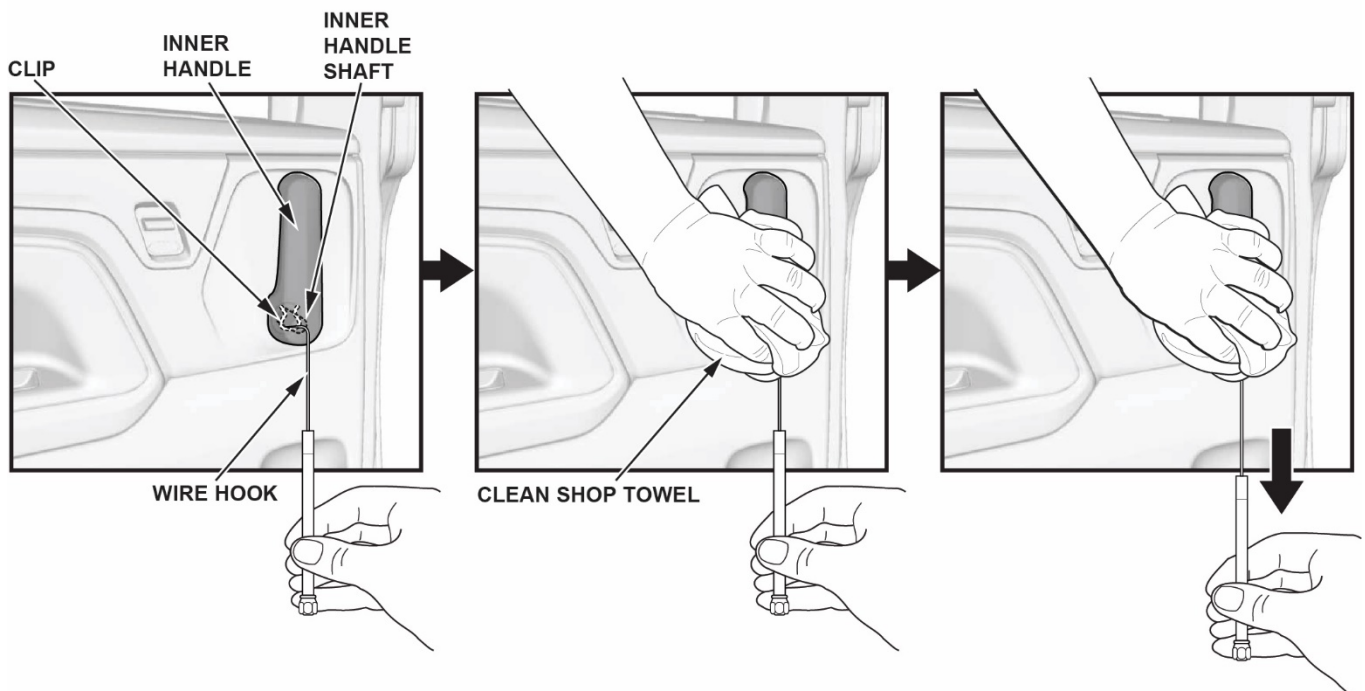

6. With the sliding door open, push the door lock knob down to the locked position to prevent it from being damaged when removing the door panel.

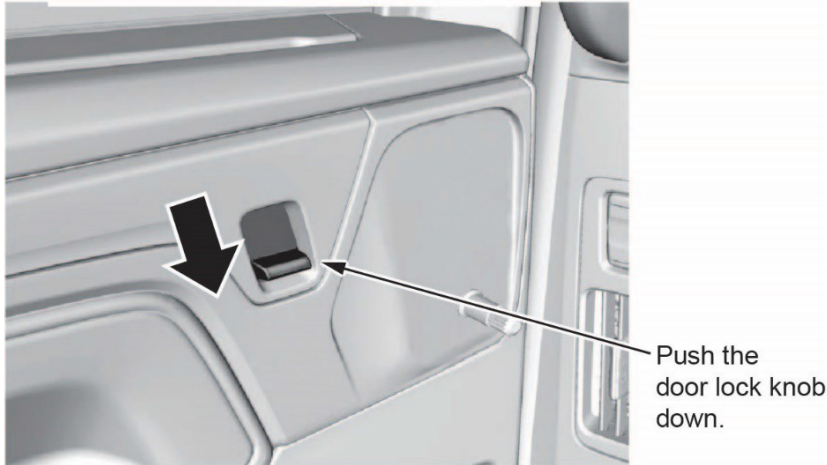

7. Remove the two clips at the bottom of the door panel first to release the lower door seal from the door panel

NOTE

Removing the two clips prevents pulling the door seal off of the door as the door panel is lifted and removed.

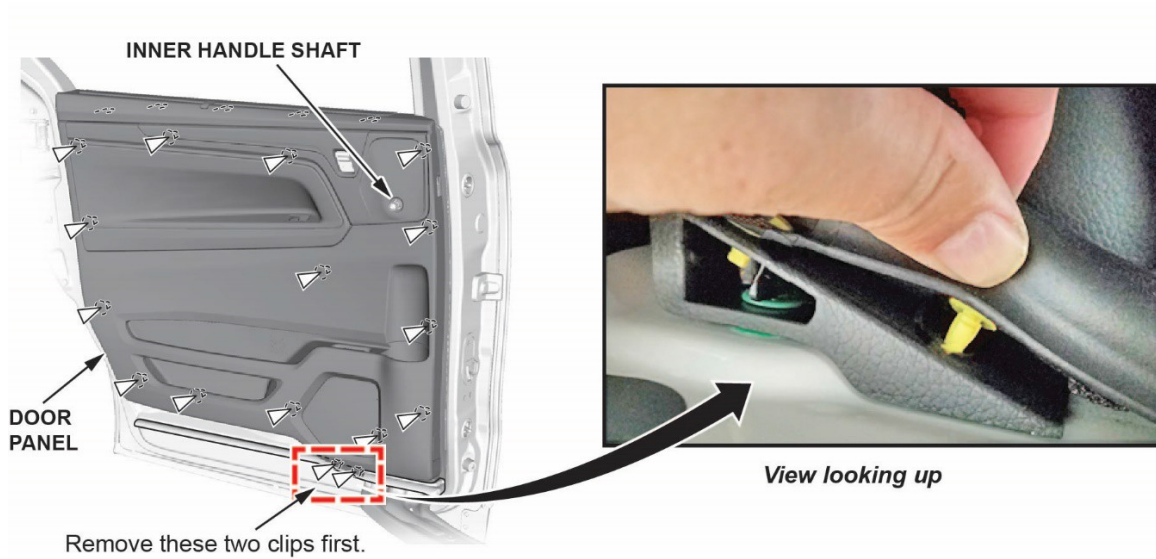

8. Starting at the bottom of the door panel, remove the remaining clips with a commercially available trim pad remover.

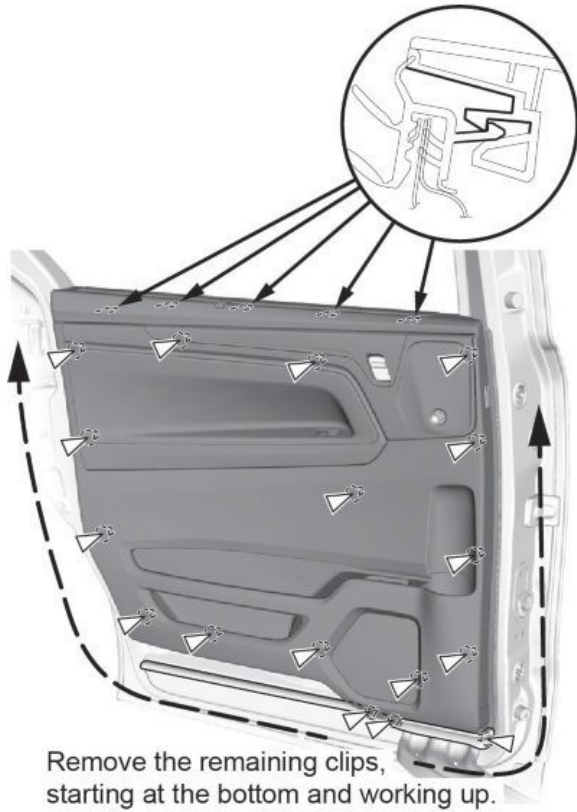

9. Starting at the rear, pull the door panel upward while making sure the clips from step 7 are free and not pulling on the lower door seal. Pull the door panel away from the inner handle shaft, and lift it upward.

NOTE

To prevent damage to the door lock knob, make sure it is in the locked position.

10. While holding the sliding door panel away from the door, disconnect the connector. Then, remove the door panel.

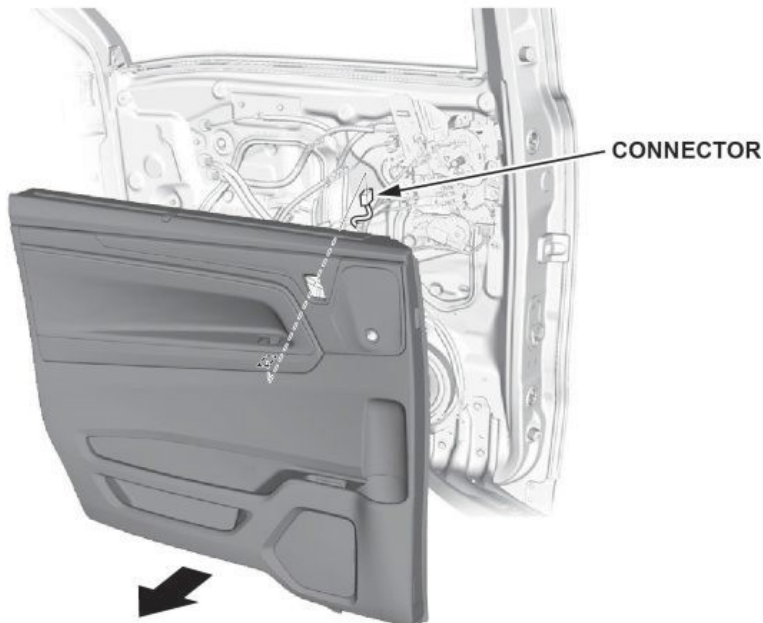

11. Remove the sliding door lock knob assembly.

11.1. Release the cable fastener.

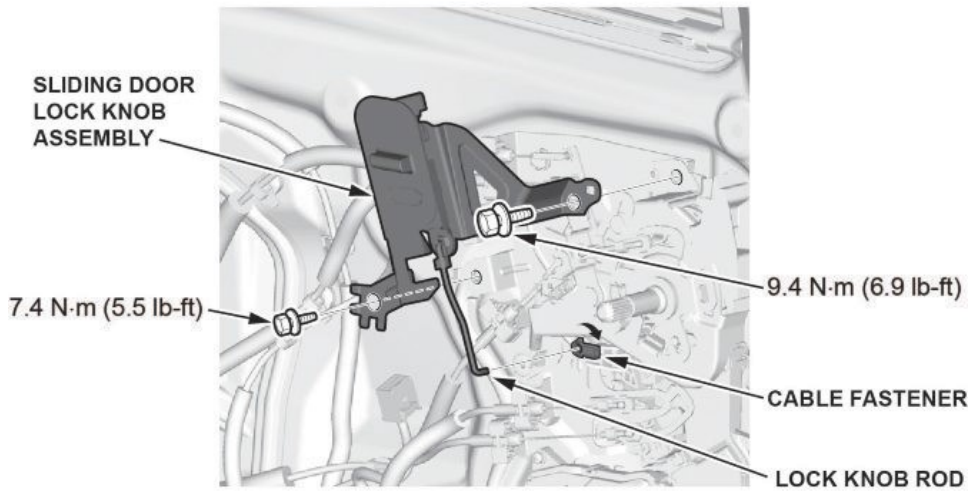

11.2. Disconnect the door lock knob rod.

11.3. Remove the sliding door lock knob assembly.

12. Disconnect the outer door handle cable from the remote control assembly.

12.1. Release the cable holder and cable fastener, then disconnect the orange outer handle cable.

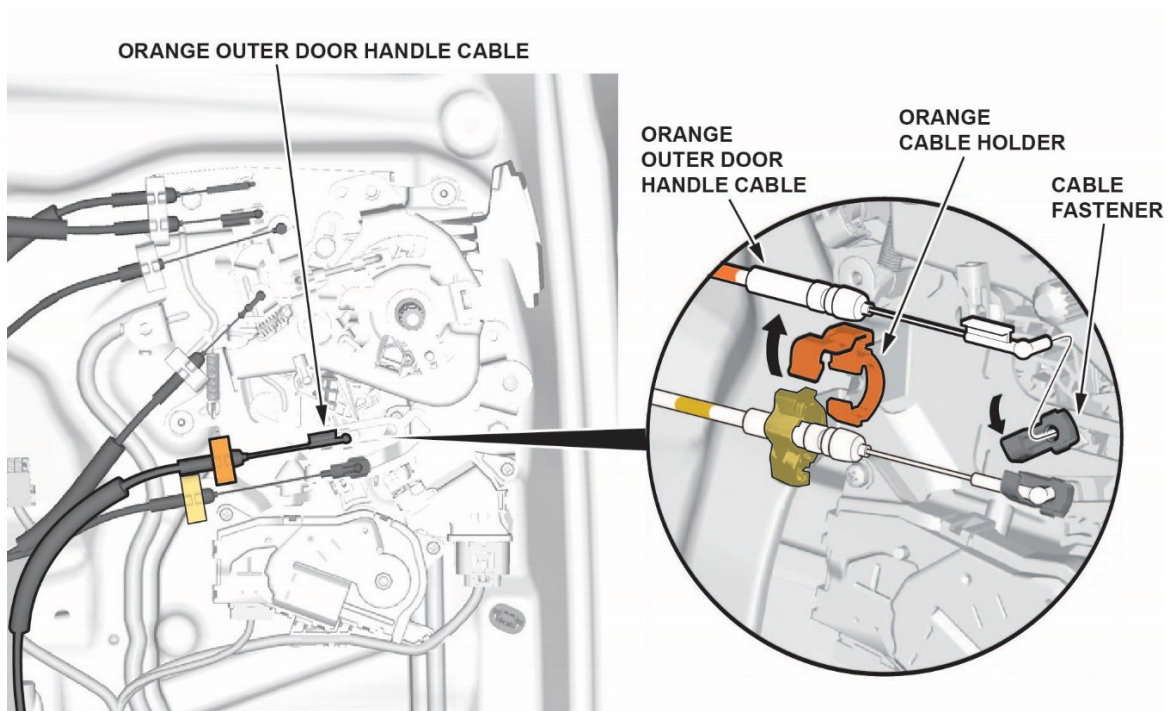

12.2. Remove the **10 mm** bolts and green clips, then detach the remote control assembly.

NOTE

Do not completely remove the remote control assembly. Just detach it from the door panel assembly to access sliding door panel barrier B.

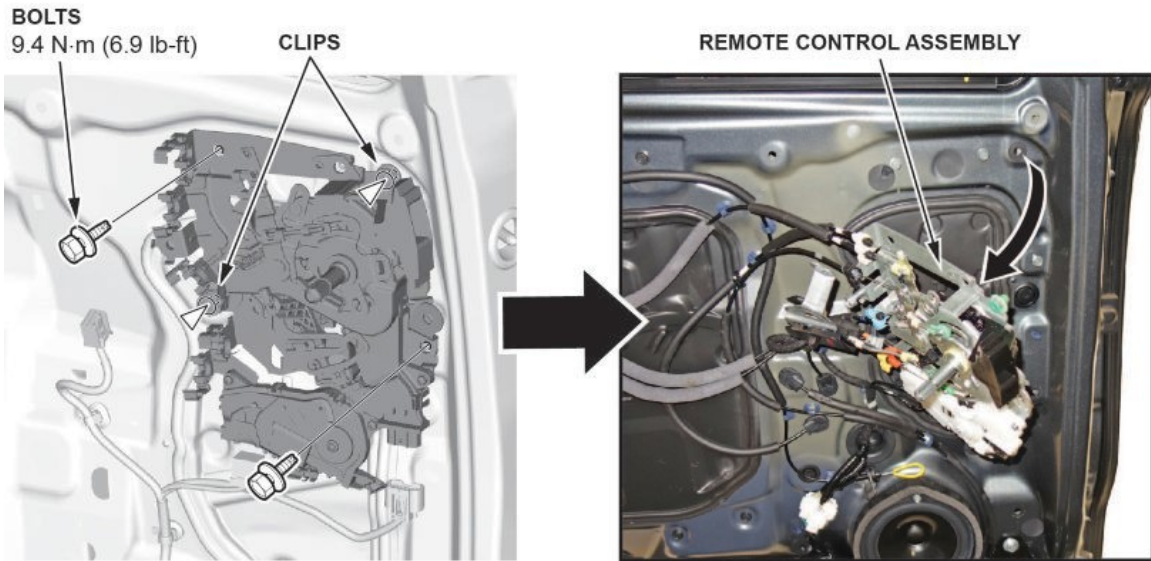

13. Remove sliding door panel barrier B.

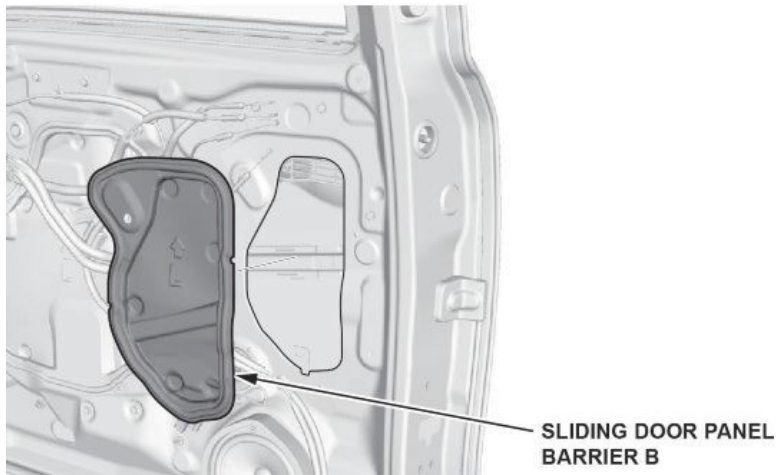

14. Remove sliding door panel plug cap A.

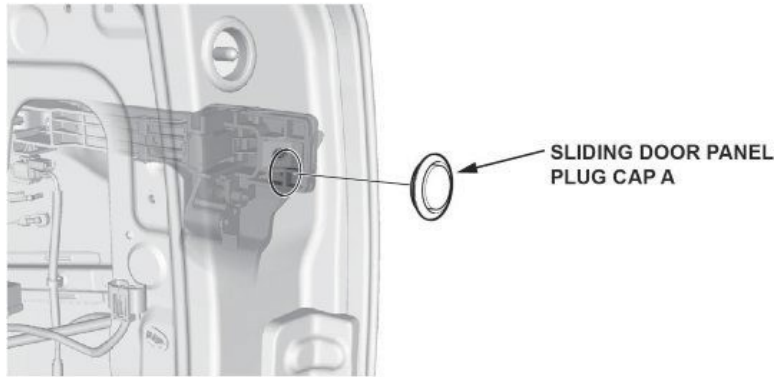

15. Insert a flat-tip screwdriver through the plug opening to detach the bush joint from the cable end fitting.

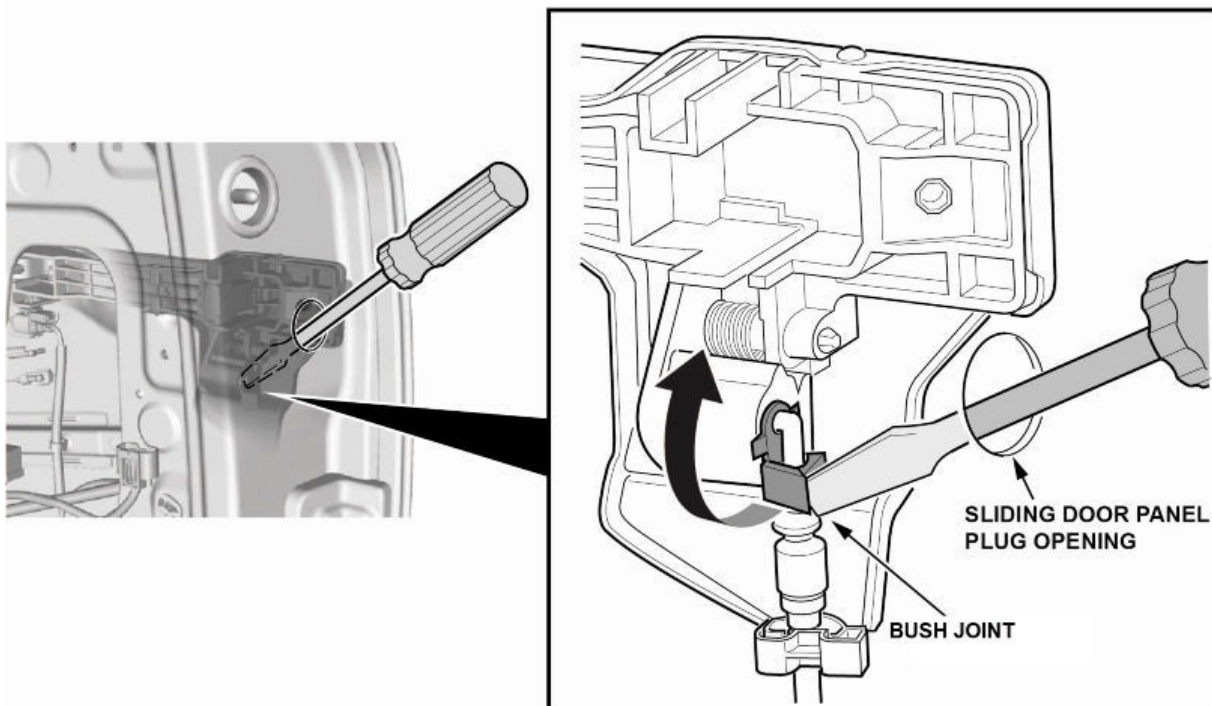

16. Sit in the sliding door opening with both legs in front of the lower roller as shown to avoid straddling the lower roller, then detach the cable holder.

NOTICE

Be careful when getting into position or exiting the vehicle. Avoid accidentally kicking and possibly damaging the sliding door articulating harness.

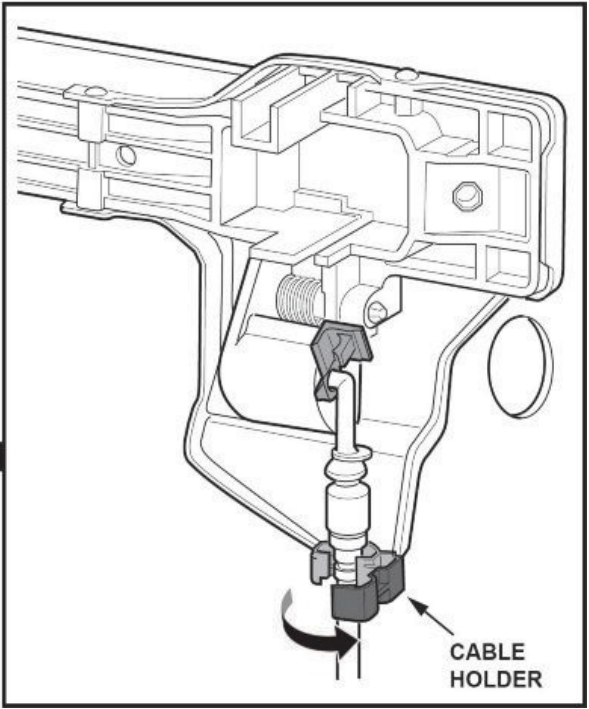

17. Insert a 1/4" extension into the back of the bush joint cavity. While pushing on the extension, insert the needle nose pliers through the plug opening to pull the cable end fitting from the bush joint.

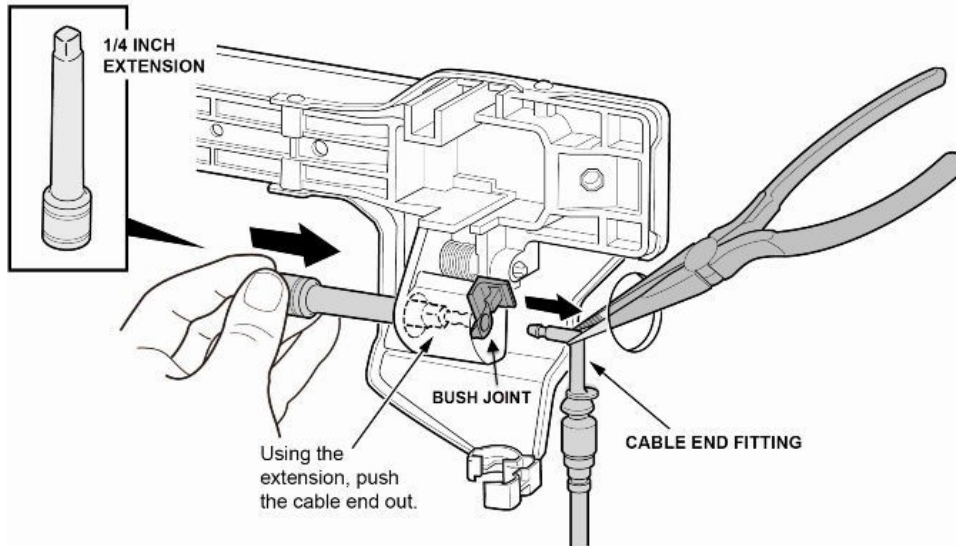

18. Release the exterior handle cable clip and the front door lock cable clip and grommet, then remove the cable from the door.

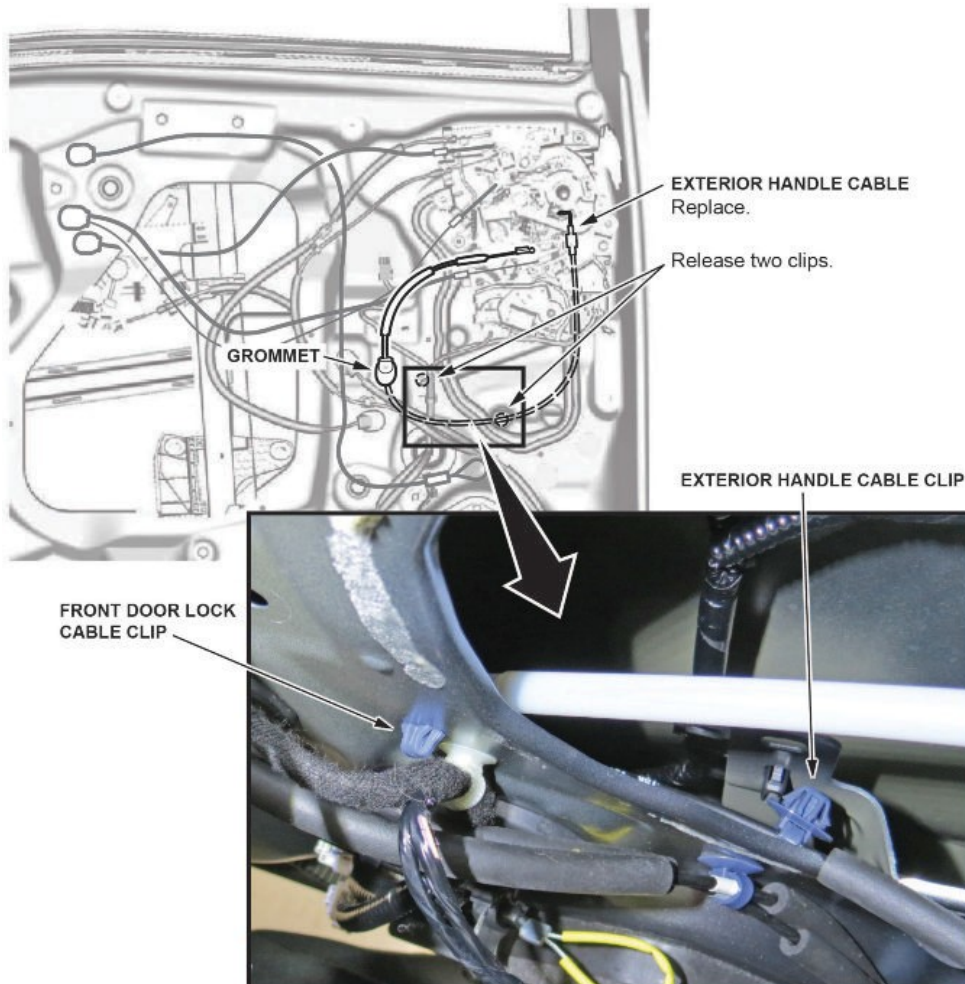

19. Place several clean shop towels into the front most corner of the door cavity to prevent the bush joint from falling into the bottom of the door should it be dropped during removal.

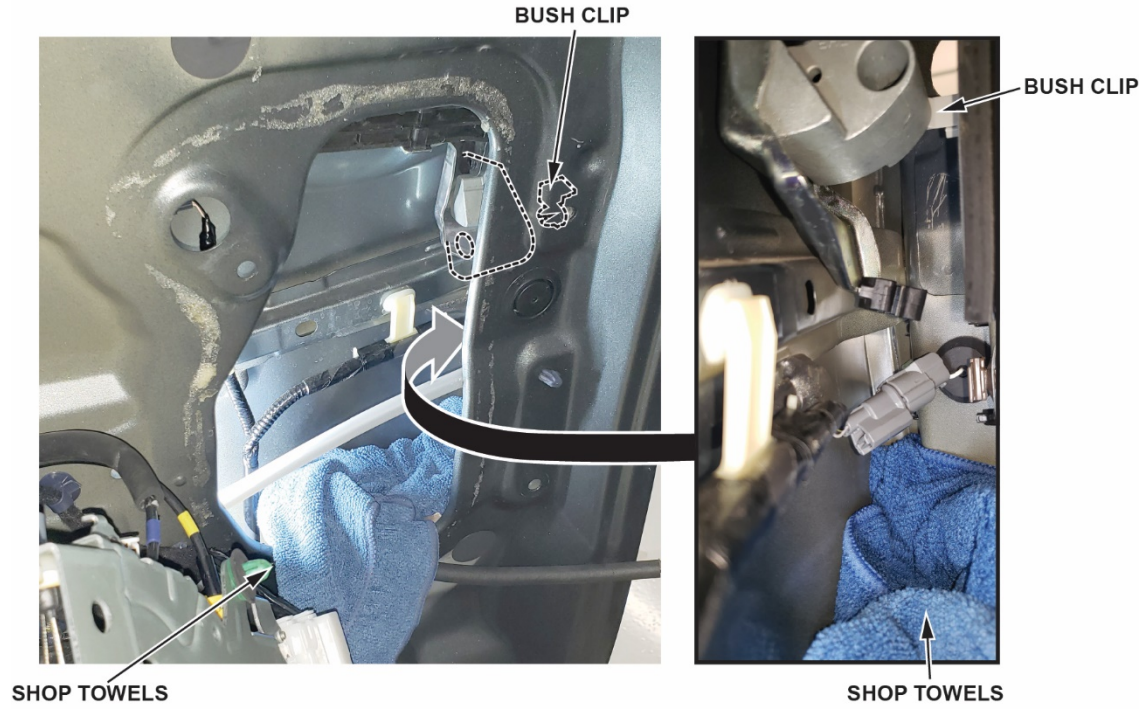

20. Insert 90° needle nose pliers through the plug opening to hold the bush joint. Insert a 1/4" drive, 6 point, 7 mm socket into the back of the bush joint cavity to compress / release the bush joint tabs, and remove the bush joint from the handle base.

NOTE

Be careful not to drop the bush joint into the door.

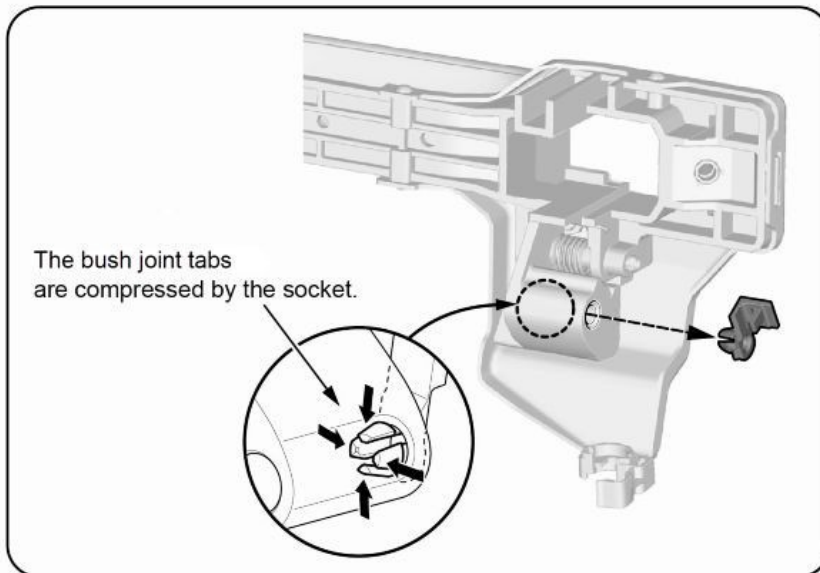
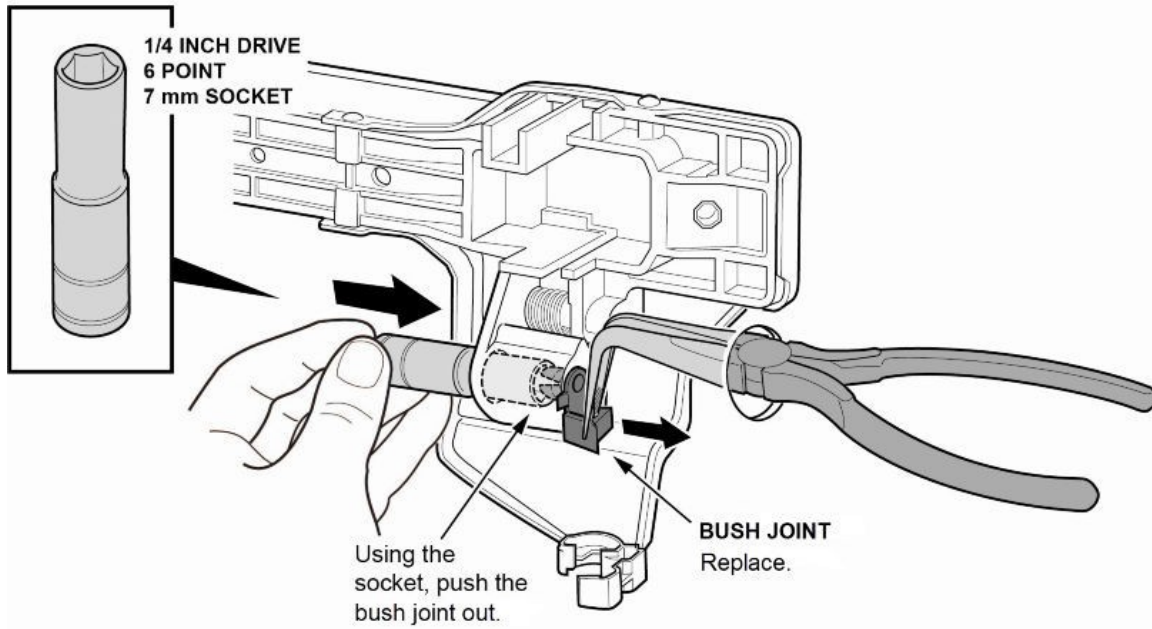

21. Use the 90° needle nose pliers to insert the new bush joint. Make sure it snaps into place and fully sets.

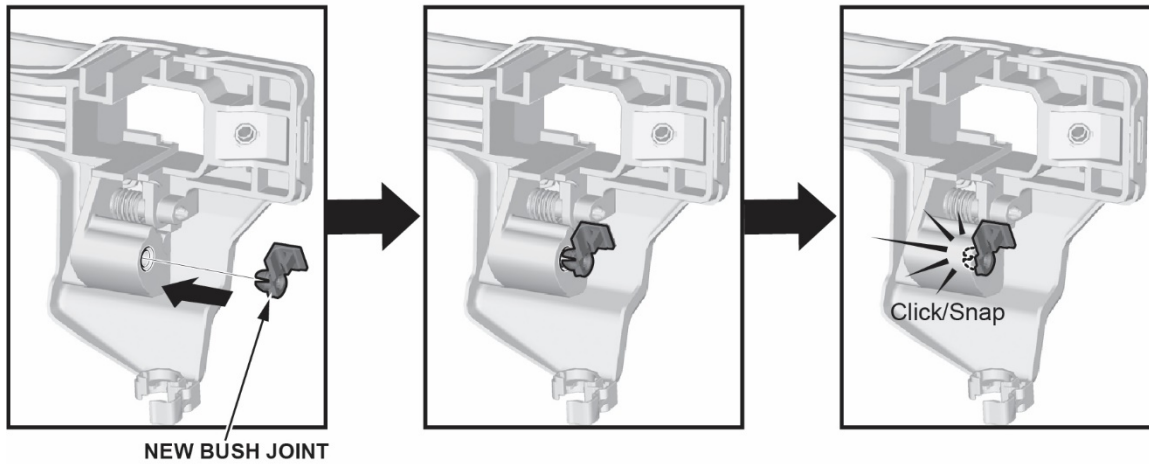

NOTE

Make sure to use the correct cable kit for the sliding door you are working on.

RIGHT CABLE AND BUSH JOINT

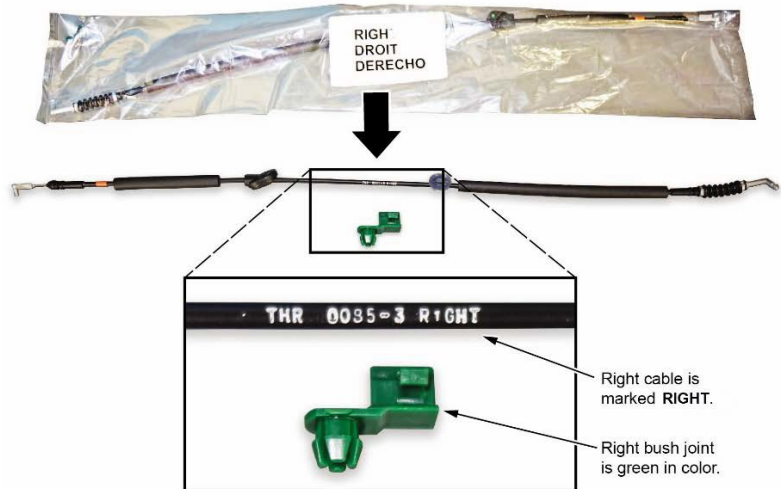

LEFT CABLE AND BUSH JOINT

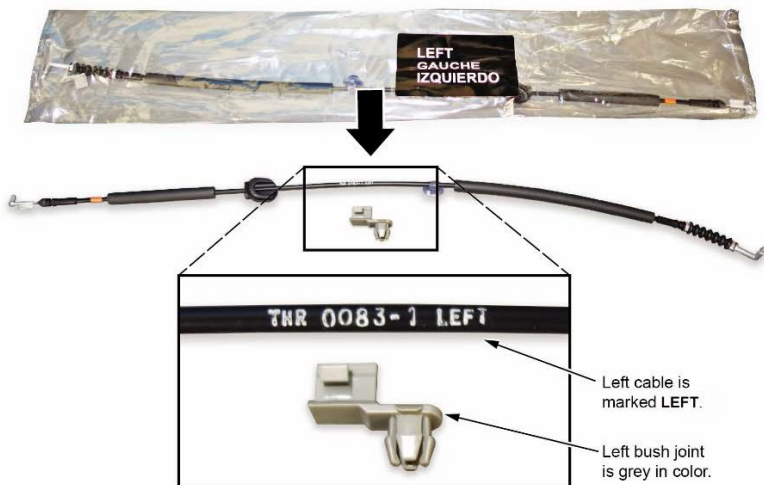

22. Install the new sliding door outer handle cable.

NOTES

- Make sure to use the correct cable kit for the sliding door you are working on.
- Make sure the cables are routed as shown.

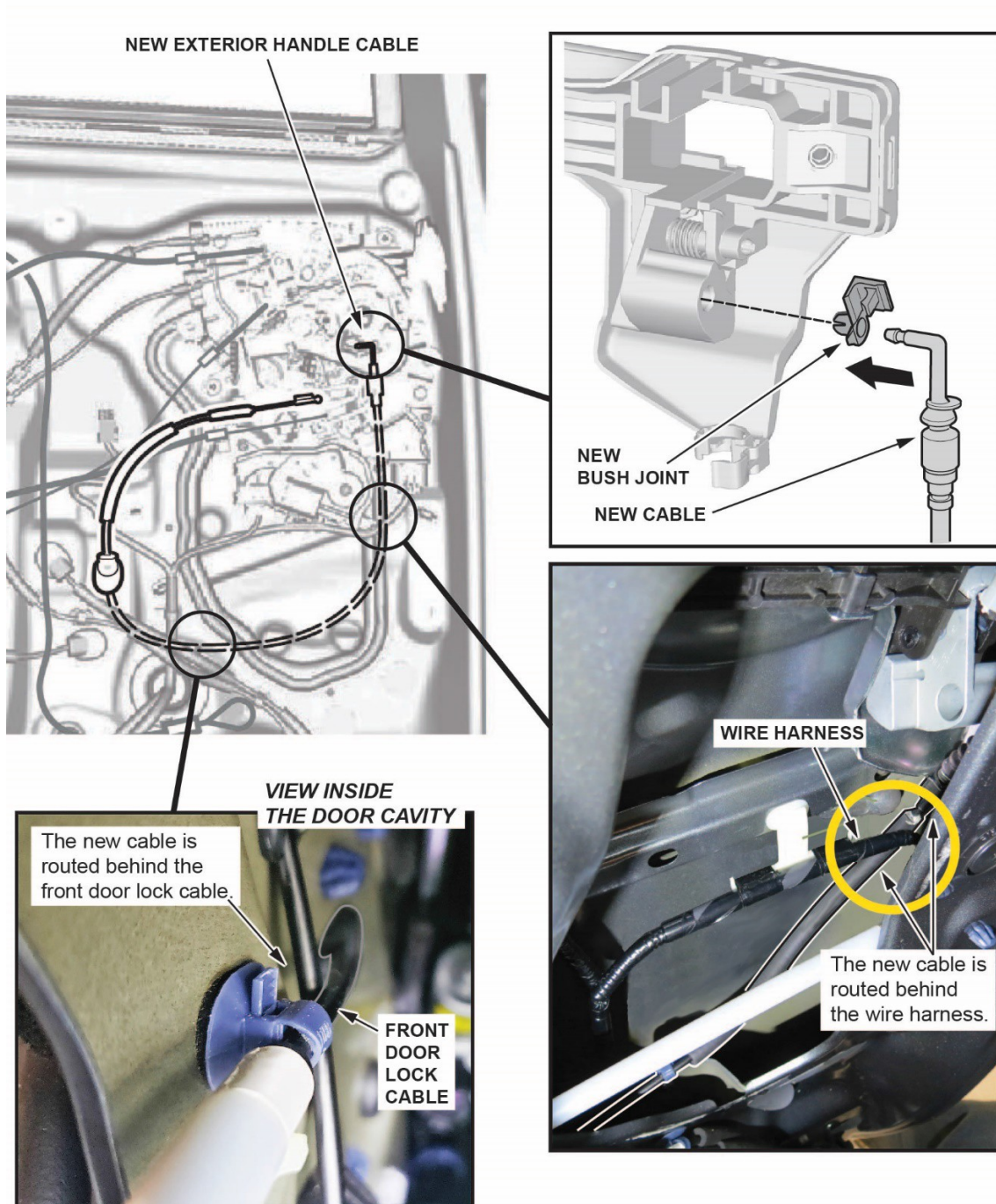

23. Install the new sliding door outer handle cables to the remote control assembly.

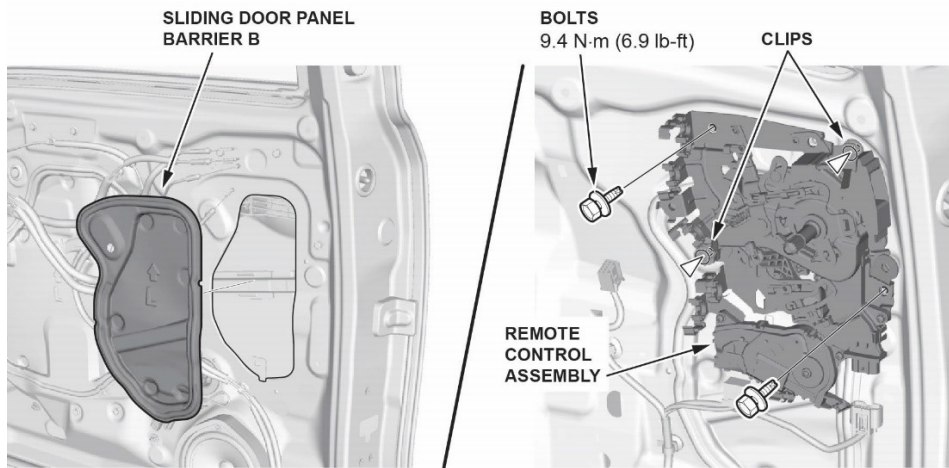

23.1. Remove the shop towels in the door cavity that was placed to prevent objects from falling into the door. Install sliding door panel barrier B, then the remote control assembly.

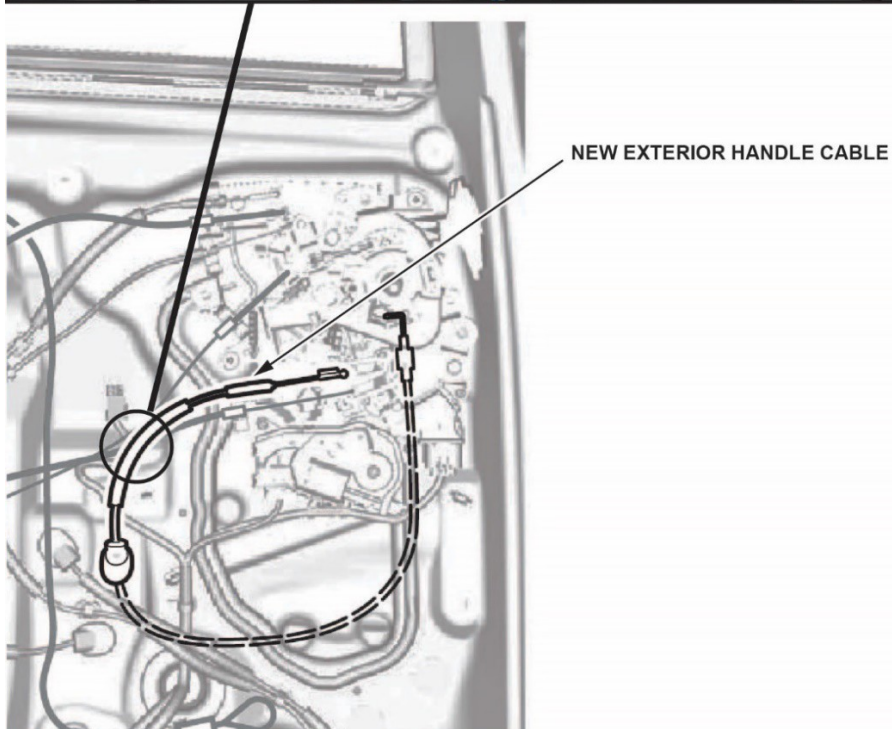
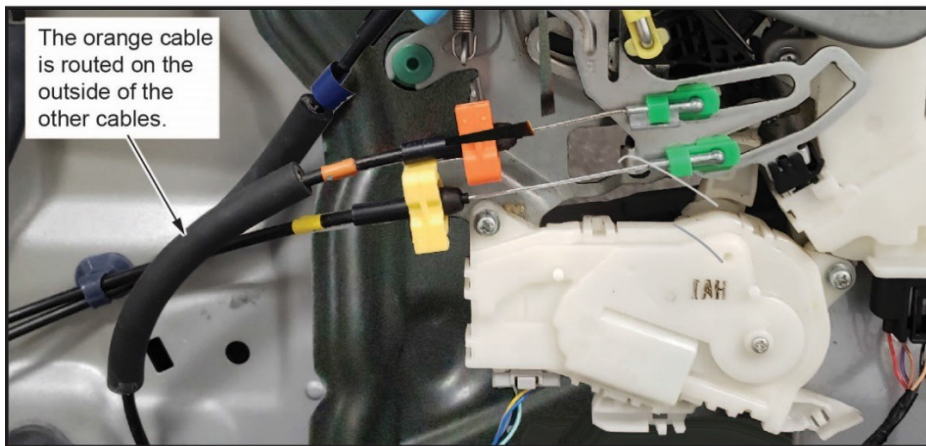

24. Install all of the remaining parts in the reverse order of removal. Tighten all fasteners to the specified torque, and make sure of the following:

- The Inner handle is fully set
- The manual lock knob functions/moves freely
- The sliding door panel plug cap A is installed
- The door liner and lower sub-seal are fully set

NOTE

To prevent miss-setting the door panel, make sure you install it exactly as shown.

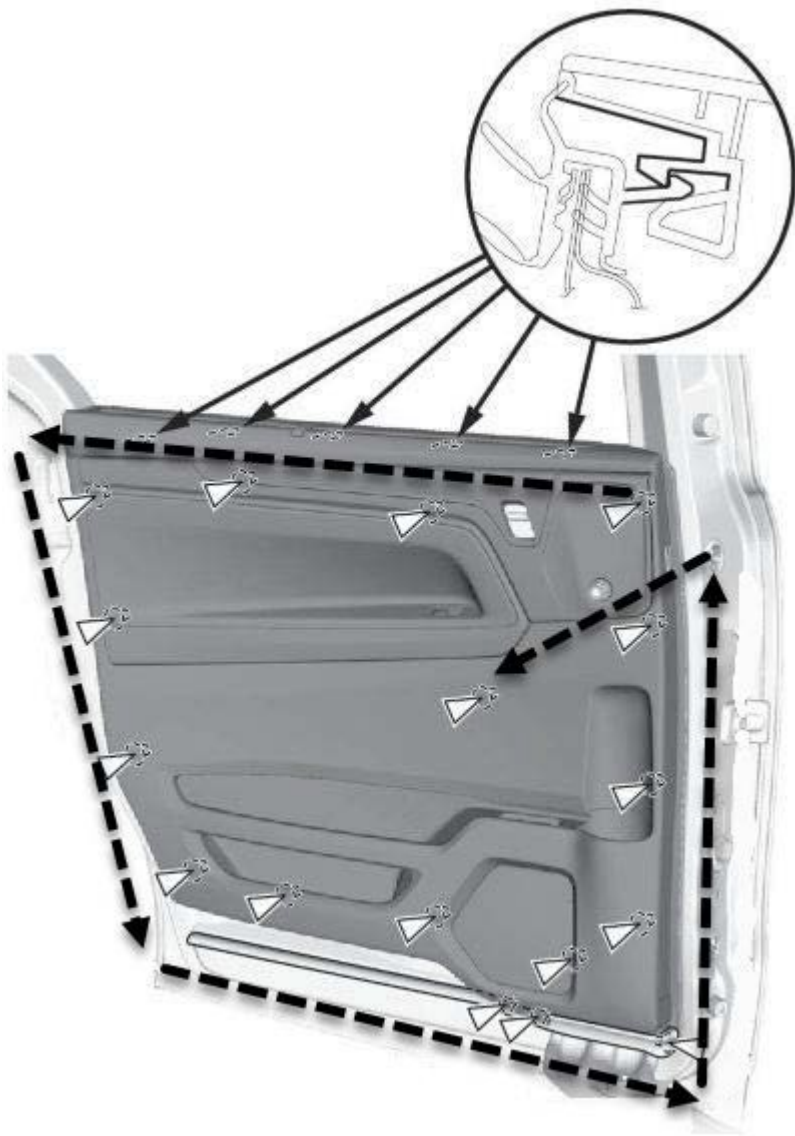

25. Replace the cable and bush joint on the other side following steps 5 thru 24.

26. Connect the battery cables.

26.1. While holding down the terminal, torque both positive and negative clamps to **35-53 lb-in (4-6 N•m)**.

NOTES

- Do not over torque the terminal.
- Always connect the positive side first.

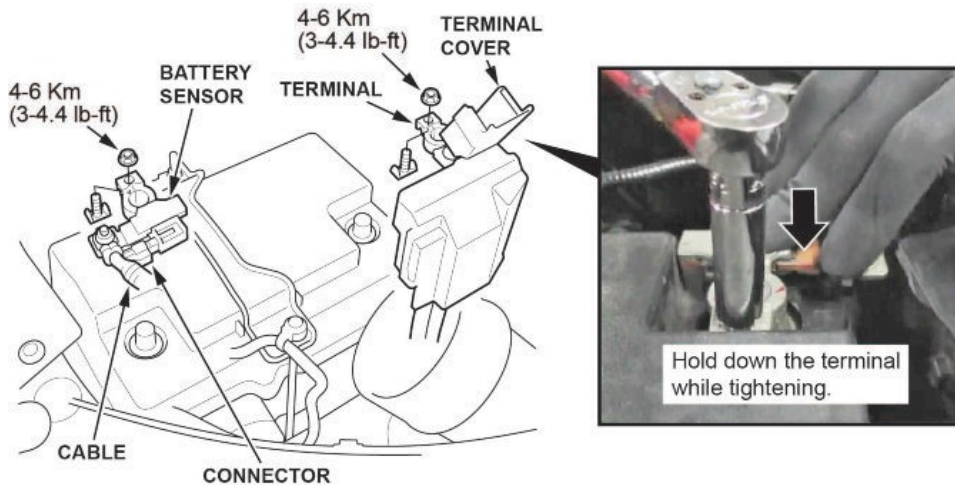

26.2. Make sure the battery terminals are correctly attached as shown.

 **GOOD**



 **NO GOOD**



27. Install the air intake duct.

28. Turn the ignition to ON.

28.1 Press and hold the volume/power knob to exit the anti-theft mode.

28.2 Make sure both sliding door window switches work properly along with the auto up/down feature.

NOTE

If you did not disconnect and connect the battery as stated in steps 4 and 26, the auto up/down feature may not work properly. To restore that feature, do the Resetting the Power Window Control Unit procedure in the service information.

29. Install the second row outer seats.

29.1 Insert the front seat hooks into the front floor strikers.



29.2 After confirming both front hooks are fully inserted into the front strikers, begin to lower the seat, then allow it to drop and lock to the rear strikers.

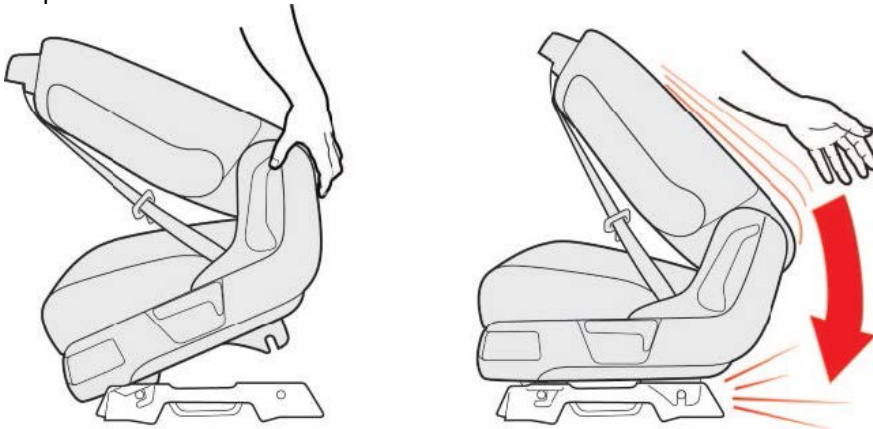

29.3 Raise the seat-back to an upright position, then rock the seat back and forth to confirm both the inner and outer latches are securely locked into position.

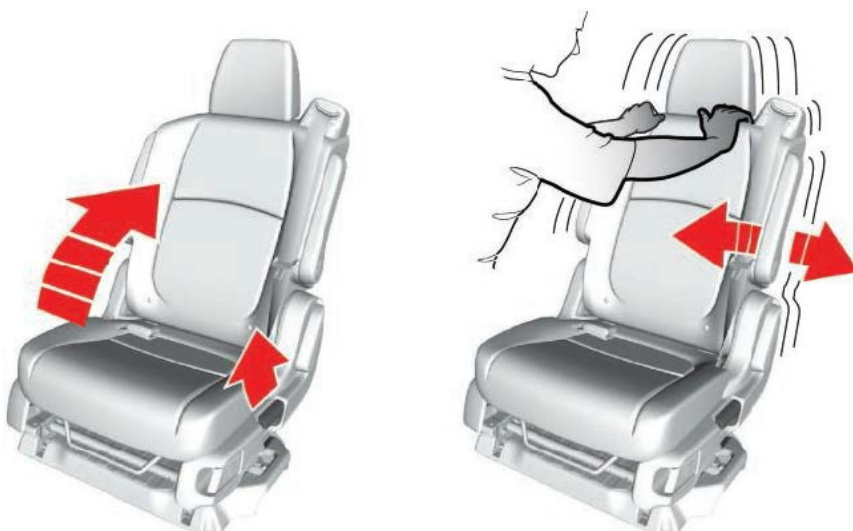

END