

N476NAS1



TECHNICAL BULLETIN

16 NOV 2020

© Jaguar Land Rover North America, LLC

NOTE: The information in Technical Bulletins is intended for use by trained, professional Technicians with the knowledge, tools, and equipment required to do the job properly and safely. It informs these Technicians of conditions that may occur on some vehicles, or provides information that could assist in proper vehicle service. The procedures should not be performed by 'do-it-yourselfers'. If you are not a Retailer, do not assume that a condition described affects your vehicle. Contact an authorized Land Rover service facility to determine whether this bulletin applies to a specific vehicle.

SECTION:

100-00

SUBJECT/CONCERN:

SAFETY RECALL: Door Will Not Latch

AFFECTED VEHICLE RANGE:

MODEL:	MODEL YEAR:	VIN:
Range Rover Sport (LW)	2014-2016	001164-620143
Range Rover (LG)	2013-2016	100107-222955

MARKETS :

USA

CONDITION SUMMARY :**SITUATION:**

An issue has been identified on certain Land Rover vehicles within the listed Affected Vehicle Range where, after Safety Recall N335 was completed, customers have reported a front and/or rear door is unlatched when in the closed position and no reported indication provided of an unlatched condition. Some customers have reported that a door has opened while the vehicle was in motion.

Vehicle doors that are not latched in either the primary or secondary state may, during driving, open. This can increase the risk of a vehicle crash or compromise the safety of vehicle occupants.

ACTION:

Retailers are required to HOLD affected new vehicles that are within your control and refrain from releasing the vehicles for new vehicle sale pending completion of the procedure(s) detailed in this Technical Bulletin. Unsold vehicles should have this performed as part of the Pre-Delivery Inspection (PDI) process but must have it completed prior to vehicle handover to the customer.

Affected vehicles already in the hands of customers should be updated at the next available opportunity.

PARTS INFORMATION:
NOTES:

- Order only the expected percentage demand of parts as identified.
- Use the Vehicle Identification Number (VIN) and the Electronic Parts Catalogue (EPC) to confirm part number(s) necessary to perform repairs.

RANGE ROVER SPORT (LW)

DESCRIPTION	PART NUMBER	QUANTITY	EXPECTED PERCENTAGE DEMAND
Front door - Door trim panel clip	LR036935	10	3%
Front door - Door trim panel clip	LR013135	22	3%
Rear door - Door trim panel clip	LR036935	10	3%
Rear door - Door trim panel clip	LR013135	18	3%

RANGE ROVER (LG)

DESCRIPTION	PART NUMBER	QUANTITY	EXPECTED PERCENTAGE DEMAND
Front door - Door trim panel clip	LR036935	10	3%
Front door - Door trim panel clip	LR013135	20	3%
Rear door - Door trim panel clip	LR036935	10	3%
Rear door - Door trim panel clip	LR013135	18	3%
Rear door - Door trim panel clip - Long wheelbase vehicles only	LR036129	12	3%

DESCRIPTION	PART NUMBER	QUANTITY	EXPECTED PERCENTAGE DEMAND
Rear door - Door trim panel clip - Long wheelbase vehicles only	LR013135	20	3%

WARRANTY INFORMATION:

NOTE:

Use the Jaguar Land Rover claims submission system to make sure that a vehicle is eligible for this program prior to undertaking any rework action.

At the time of confirming a booking for vehicle repair, make sure that all open Recall and Service Actions are identified to make sure the correct parts are available and adequate workshop time is allocated for repairs to be completed at one visit.

Warranty claims must be submitted quoting the Program Code, Option Code 'X', and the relevant SRO(s) and parts information from the tables below. The Option Code(s) that allows for the drive in/drive out allowance may only be claimed if the vehicle is brought back into the workshop for this action alone to be undertaken.

Repair procedures are under constant review and therefore times/prices are subject to change; those quoted here must be taken as guidance only. Use TOPIx to obtain the latest repair time.

Warranty claims must be submitted or payment within 30 calendar days of completion of the repair.

RANGE ROVER SPORT (LW)

DESCRIPTION	SRO	TIME
Door latch - Inline Diagnostic Unit 2 (IDU2) Application - Remote Function Actuator (RFA) software update - No further action required	85.99.10	0.3
Door latch - Front - Modification - Single	99.02.11	0.8
Door latch - Front - Modification - Pair	99.02.12	1.6

DESCRIPTION	SRO	TIME
Door latch - Rear - Modification - Single	99.02.13	0.7
Door latch - Rear - Modification - Pair	99.02.14	1.4
Remove and install spare wheel and tire assembly - If required	05.10.10	0.1
Drive in/drive out	02.02.02	0.2

RANGE ROVER (LG) - Standard Wheelbase

DESCRIPTION	SRO	TIME
Door latch - IDU2 Application - RFA software update - No further action required	85.99.10	0.3
Door latch - Front - Modification - Single	99.02.11	0.8
Door latch - Front - Modification - Pair	99.02.12	1.5
Door latch - Rear - Modification - Single	99.02.13	0.8
Door latch - Rear - Modification - Pair	99.02.14	1.6
Remove and install spare wheel and tire assembly - If required	05.10.10	0.1
Drive in/drive out	02.02.02	0.2

RANGE ROVER (LG) - Long Wheelbase

DESCRIPTION	SRO	TIME
Door latch - IDU2 Application - RFA software update - No further action required	85.99.10	0.3
Door latch - Front - Modification - Single	99.02.11	0.8
Door latch - Front - Modification - Pair	99.02.12	1.5
Door latch - Rear - Modification - Single	99.02.13	1.0
Door latch - Rear - Modification - Pair	99.02.14	1.9

DESCRIPTION	SRO	TIME
Remove and install spare wheel and tire assembly - If required	05.10.10	0.1
Drive in/drive out	02.02.02	0.2

Normal Warranty policies and procedures apply.

CUSTOMER REIMBURSEMENT PROCESS:

If a customer has indicated that they have already paid for this concern as a normal retail repair (vehicle outside warranty period), a copy of the repair invoice must be produced as proof of the repair. The retailer must directly reimburse the customer and a claim for recovery of this cost should be made using the related damage procedure. Claims for related damages can only be made when this bulletin has been paid/accepted.

Claims should be submitted quoting Program Code N476 and by clicking the 'Related Damage' radio button on the claim submission screen. The warranty claim should be submitted using Option Code 'X' as detailed in the table shown below and entering the cost to be reimbursed against the Sundry Code of 'ZZZ999'. All costs should be entered in local currency.

PROGRAM CODE	OPTION CODE	DESCRIPTION	SUNDRY CODE	VALUE
N476	X	Reimbursement to owner	ZZZ999	Retailer entered

A copy of the invoice must be attached to the repair order for Warranty Audit purposes.

A brief comment should be entered in the 'Technician Comments' field on the claim to itemize and explain the charges.

Only vehicles eligible for Recall Action N476 are included in this process. Only one claim per vehicle for related damages will be accepted.

SERVICE INFORMATION:

-
1. Any door latch that does not lock must be investigated and rectified before continuing to the Diagnostic Instruction below (see TOPIx Workshop Manual section 501-14: Diagnosis and Testing - Locks Latches and Entry System). Any components that require renewing as a result of completed investigations are outside the scope of this recall. Normal warranty policy / procedures apply for any repairs outside the scope of the recall.

DIAGNOSTIC INSTRUCTION:

CAUTION:

All ignition ON/OFF requests **MUST** be performed; failure to do so may cause damage to vehicle control modules.

1.

CAUTION:

A Jaguar Land Rover-approved battery support unit must be connected to the vehicle startup battery during diagnosis / module programming.

Connect the Jaguar Land Rover-approved battery support unit to the vehicle startup battery.

2.

NOTE:

The Jaguar Land Rover-approved diagnostic equipment must be loaded with SDD160.01 Software Management Pack v341 (or later).

Connect the Jaguar Land Rover-approved diagnostic equipment to the vehicle and begin a new session.

3.

NOTE:

If required: the Jaguar Land Rover-approved diagnostic equipment will read the VIN for the current vehicle and automatically take the vehicle out of Transit mode.

Follow all on-screen instructions.

4. ■ If the link is not available:

- Select the **Service Functions** session type.
- Select **Run** to perform the '**Inline diagnostic unit 2 diagnostic test - Remote function actuator US campaign**' option.

NOTES:

- During the application, the technician will receive a 'pass' or 'fail' result for each door latch. A failed door latch(es) will require modification AFTER this ENTIRE Diagnostic Instruction has been completed.
 - The Smart Key must be on your person when operating the door handles.
 - If any of the door latch tests ask to operate the door handle more than 5 operations, it is possible that the handle is not being pulled quickly enough. The technician's hand must be inserted behind the handle and the handle pulled within 0.3 seconds to make sure the keyless vehicle motor is cycled.
 - It may be necessary during the IDU2 diagnostic application, to complete a mid-application repair detailed within the application itself, if at any stage it is not possible to latch and lock the door.
 - During the application, if the fuse which requires testing is located in the Central Junction Box (CJB), the IDU2 will require connecting to the startup battery jump posts located under the hood. After opening the hood, the hood latches must be manually latched to allow the vehicle to be locked as required when completing the application.
- Follow all on-screen instructions to complete the task.

-
5. **Only if required:** set the vehicle to Transit mode.
 - 1. Follow the on-screen instructions until the application finishes successfully.
-
6. Exit the current session.
-
7. Disconnect the diagnostic equipment and battery support unit from the vehicle.
-
8. **Only if necessary:** go to the Service Instruction below if any door latch failed the application completed within this Diagnostic Instruction.

SERVICE INSTRUCTION:

NOTES:

- Only remove/modify the door latch(es) that failed the IDU2 application.
- Some variation in the illustrations may occur, but the essential information is always correct.
- Some components shown removed for clarity.

-
1. Remove the failed front and/or rear door latch(es).
 - 1. **Front Door Latch Removal:**see TOPIx Workshop Manual section 501-14: Handles, Locks, Latches and Entry Systems - Removal and Installation - Front Door Latch [steps 1-8].
 - 2. **Rear Door Latch Removal:** see TOPIx Workshop Manual section 501-14: Handles, Locks, Latches and Entry Systems - Removal and Installation - Rear Door Latch [steps 1-6].

Steps 2-8: Door Latch Modification

NOTE:

Only complete steps 2-8 for the door latch that has failed the IDU2 test.

2.

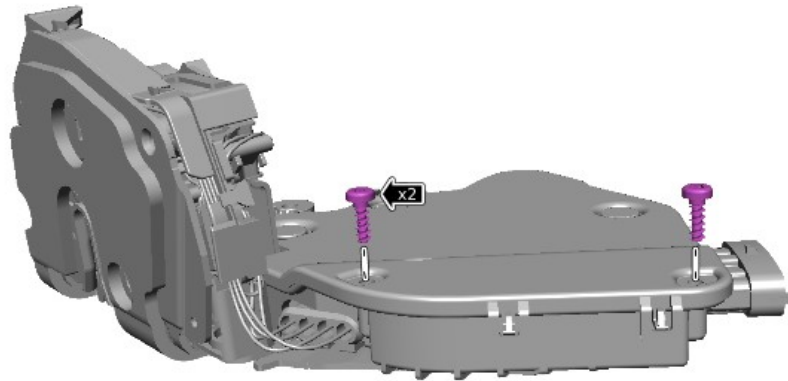

E249343

Remove the 2 retaining screws from the door latch cover.

3.

NOTE:

Only reposition the door latch cover; removal of the cover will cause damage to the door latch.

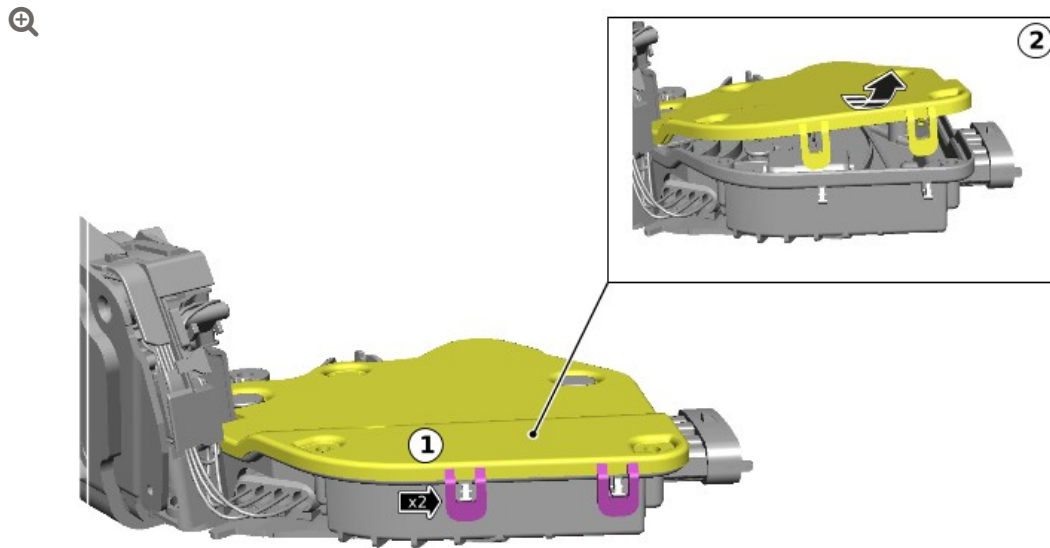

E249345

Access the inside of the door latch.

- 1. Release the 2 door latch cover retaining clips.
- 2. Reposition the door latch cover as shown.

4.

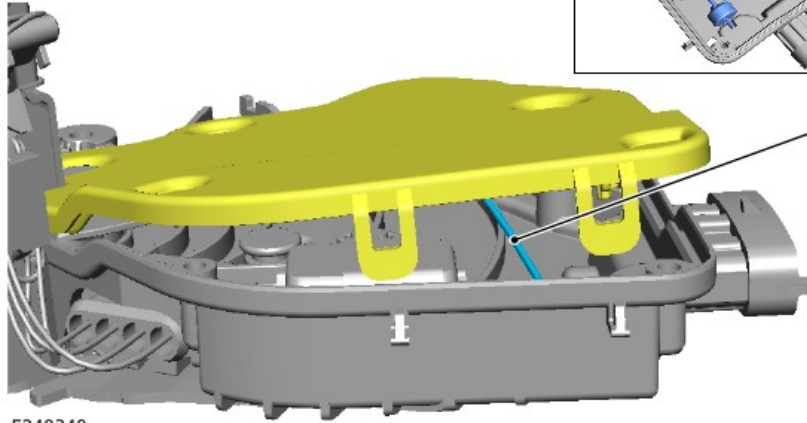

E249349

Locate the keyless vehicle motor cord.

5.

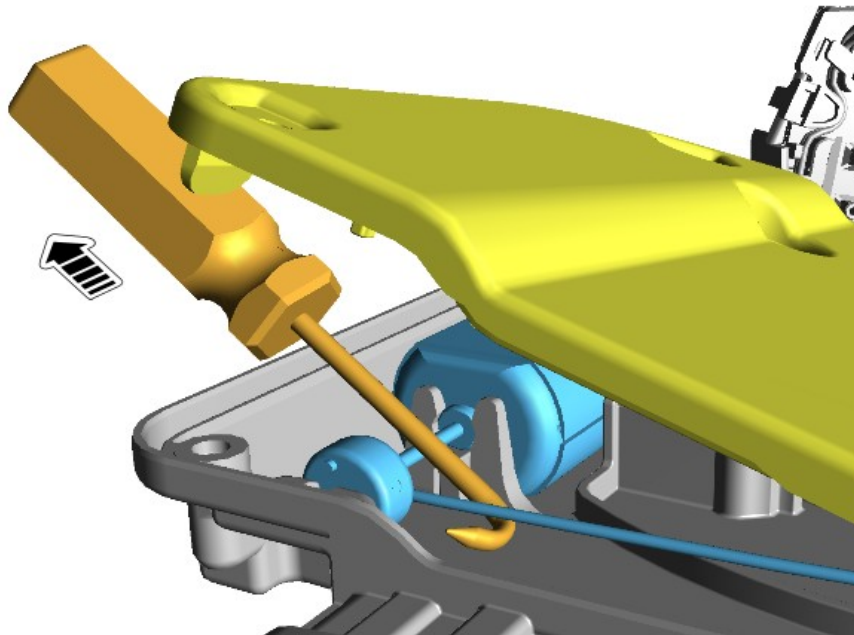

E249364

Use a suitable hook tool to pull the keyless vehicle motor cord as far as it will travel.

6.

NOTES:

- Allow 40-60 mm of cord from the motor spindle before cutting.
- After cutting the keyless vehicle motor cord, make sure the lever returns back the original position.

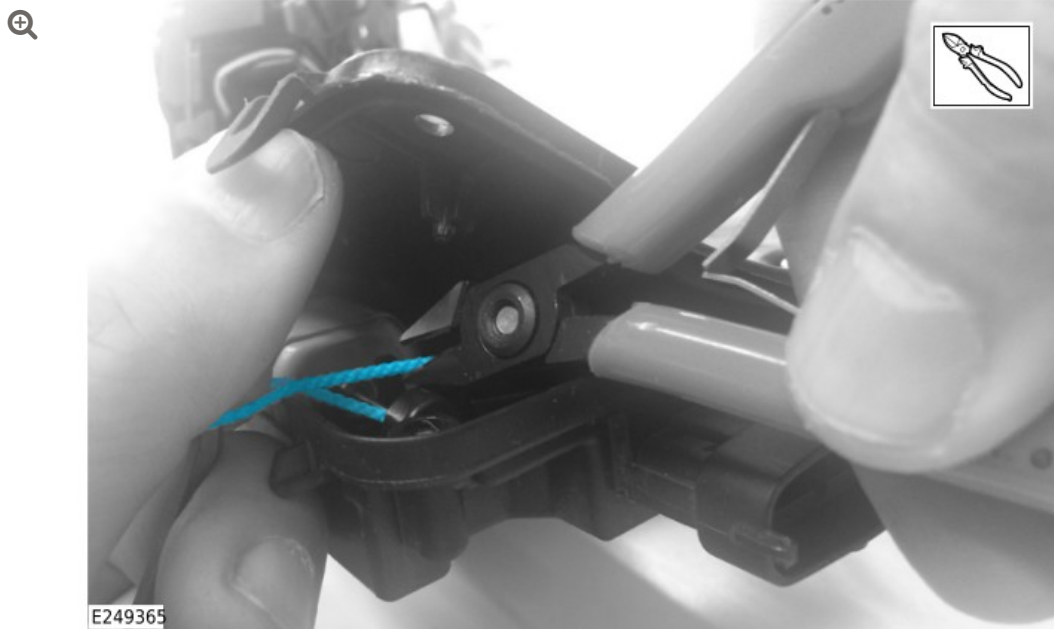

Use a suitable tool to cut the keyless vehicle motor cord.

7.

NOTE:

Make sure the excess keyless vehicle motor cord remains inside the door latch housing before installing the door latch cover.

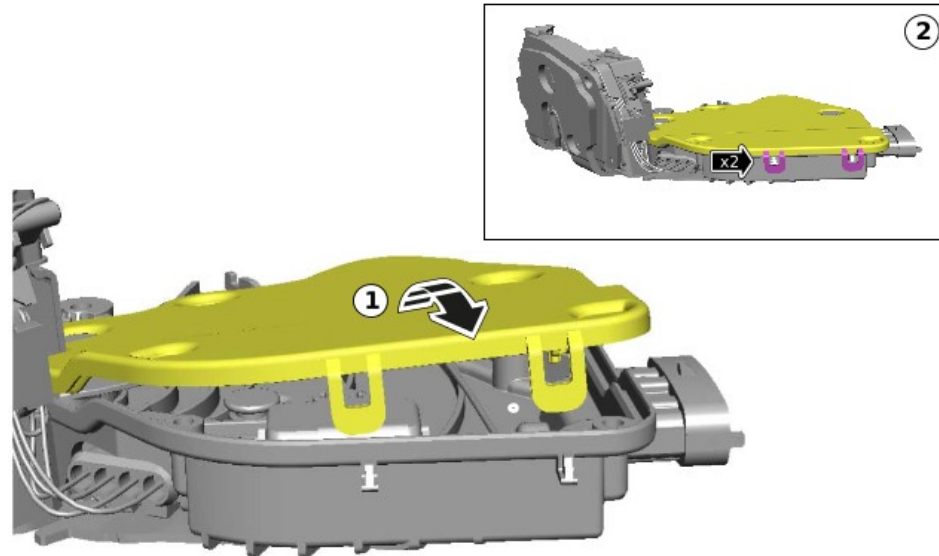

E249348

Install the door latch cover.

- 1. Reposition the door latch cover.
- 2. Secure the 2 door latch cover retaining clips.

8. ■

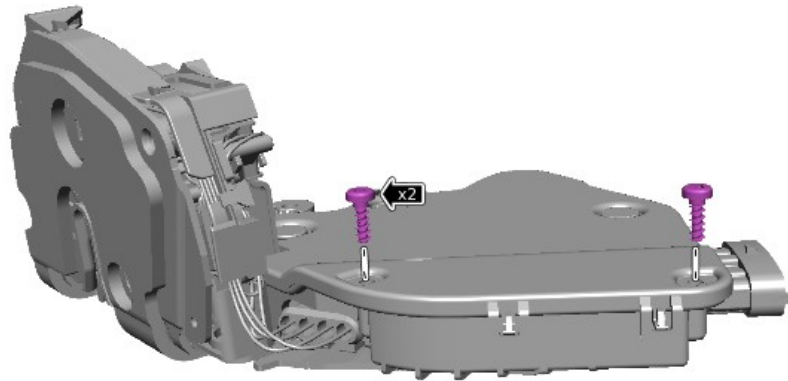

E249343

Install the retaining screws.

- Torque: **1.2 Nm**

-
9. Install the modified front and/or rear door latch(es).
- 1. **Front Door Latch Installation:** see TOPIx Workshop Manual section 501-14: Handles, Locks, Latches and Entry Systems - Removal and Installation - Front Door Latch [**reverse steps 1-8**].
 - 2. **Rear Door Latch Installation:** see TOPIx Workshop Manual section 501-14: Handles, Locks, Latches and Entry Systems - Removal and Installation - Rear Door Latch [**reverse steps 1-6**].
-
10. Repeat steps 1-9 of this Service Instruction for any other front and/or rear door latch that has failed the IDU2 test.