

**July 30, 2021**

Version 4

**Safety Recall: 2018-19 HR-V AWD Fuel Pump Motor**Supersedes 20-052, dated April 27, 2021 to revise the section highlighted in **yellow**.**AFFECTED VEHICLES**

Year	Model	Trim Level	VIN Range
2018–19	HR-V AWD	ALL	Check the iN VIN status for eligibility.

**REVISION SUMMARY****Under REPAIR PROCEDURE, steps 7, 9.1, 9.2, 9.3, 9.4, and 10.4 were revised.****BACKGROUND**

Due to swelling of the fuel pump motor impeller, the fuel pump may seize and stop working. If this occurs, the engine may not start, or the engine could stall while driving, increasing the risk of a crash.

**This service bulletin is only for the HR-V AWD. If working on an HR-V 2WD, go to service bulletin 20-053, Safety Recall: 2018-19 HR-V 2WD Fuel Pump Motor.**

**CUSTOMER NOTIFICATION**

Owners of affected vehicles will be sent a notification of this campaign.

Do an iN VIN status inquiry to make sure the vehicle is shown as eligible.

Failure to repair a vehicle subject to a recall or campaign may subject your dealership to claims or lawsuits from the customer or anyone else harmed as a result of such failure. To see if a vehicle in inventory is affected by this safety recall, do a VIN status inquiry before selling it.

**CORRECTIVE ACTION**

Replace the fuel pump motor.

**PARTS INFORMATION**

NOTE: Due to limited supply, this will be a controlled part and will require a valid VIN when ordering.

Part Name	Part Number	Quantity
Fuel Pump Motor Kit (AWD)	06170-T7L-305	1

**For dealers experiencing a strong fuel smell from storing a fuel pump motor replaced under this service bulletin**, the fuel pump motor may be disposed of immediately in accordance with local regulations. This only applies to the fuel pump motor replaced under this service bulletin. The published retention policy remains in effect for all other parts. If you have any questions about this exception or other parts retention issues, contact the WPI Administrative Office at **937-642-2737**.

**CUSTOMER INFORMATION:** The information in this bulletin is intended for use only by skilled technicians who have the proper tools, equipment, and training to correctly and safely maintain your vehicle. These procedures should not be attempted by "do-it-yourselfers," and you should not assume this bulletin applies to your vehicle, or that your vehicle has the condition described. To determine whether this information applies, contact an authorized Honda automobile dealer.

## TOOL INFORMATION

Tool Name	Tool Number	Quantity
Fuel Nut Wrench (Fuel Sender Wrench)	070AA-T0AA100 or 07AAA-T0AA100	1

## WARRANTY CLAIM INFORMATION

Operation Number	Description	Flat Rate Time	Defect Code	Symptom Code	Template ID	Failed Part Number
3101HK	Replace the fuel pump motor.	1.2 hr	6FE00	K7X00	A20052A	17045-T7X-A01

## REPAIR PROCEDURE

### ⚠ WARNING

Fuel pump motor removal exposes fuel, which can ignite, causing a fire or explosion. This can cause serious injury or death. Always work in a well-ventilated area, and keep sparks or open flames away.

1. Relieve the fuel pressure.
  - 1.1. Remove the fuel fill cap to relieve the pressure in the fuel tank.
  - 1.2. Remove PGM-FI main relay 2 from the under-dash fuse/relay box.

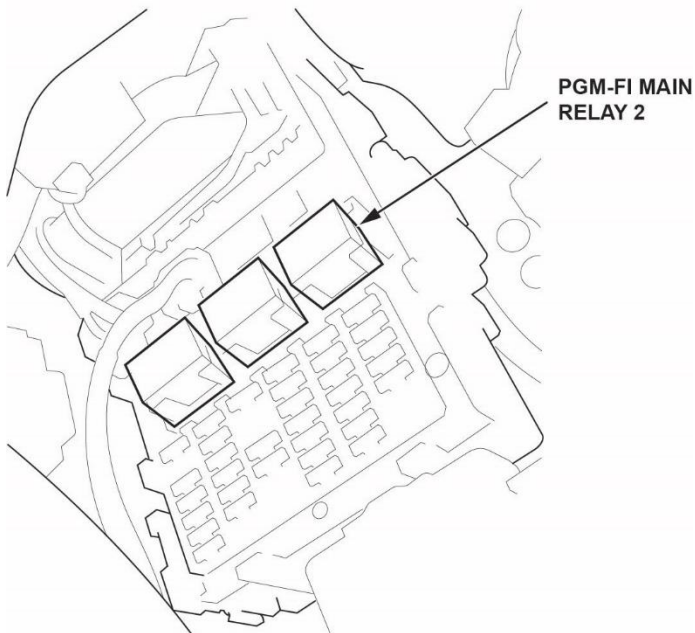

- 1.3. Start the engine, and let it idle until it stalls.
- 1.4. Turn the ignition to OFF.
- 1.5. Install PGM-FI main relay 2.

2. Remove the driver's seat.

2.1. Remove the driver's seat front foot covers (if equipped).

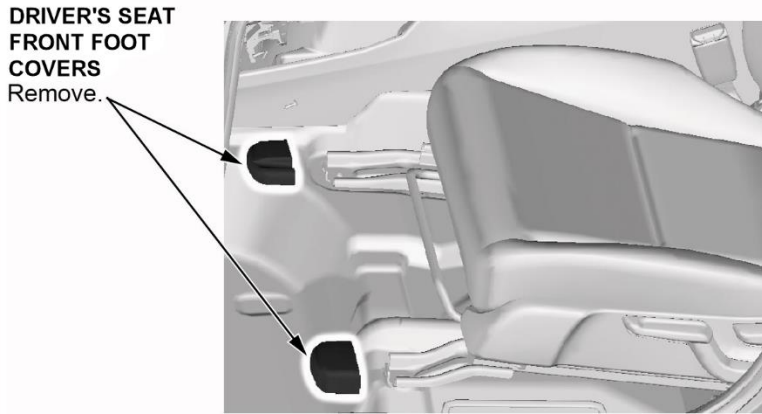

2.2. Remove the driver's seat rear foot covers (if equipped).

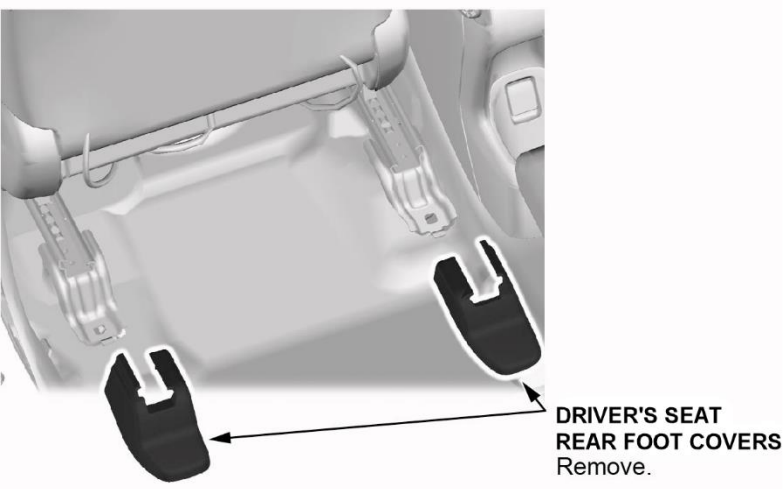

2.3. Remove the driver's seat mounting bolts.

**REAR SIDE**

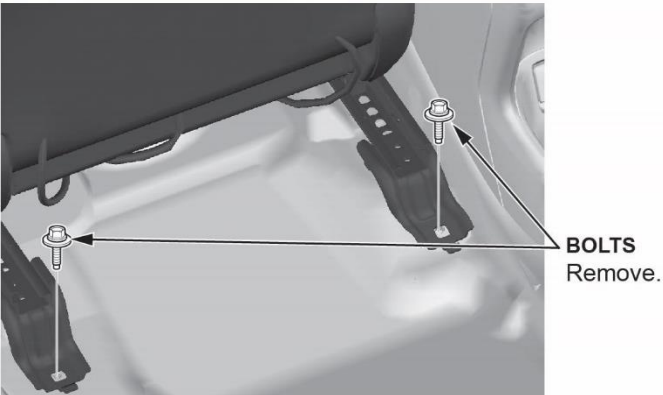

**FRONT SIDE**

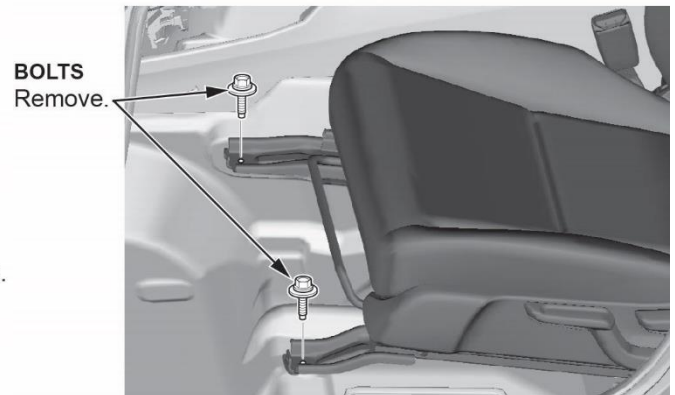

2.4. Disconnect both 12-volt battery terminals.

**NOTICE**

- Always disconnect the negative terminal first.
- To protect the terminal connector from damage, do not hold it when removing the terminal.
- Do not disconnect the 12-volt battery sensor from the cable.

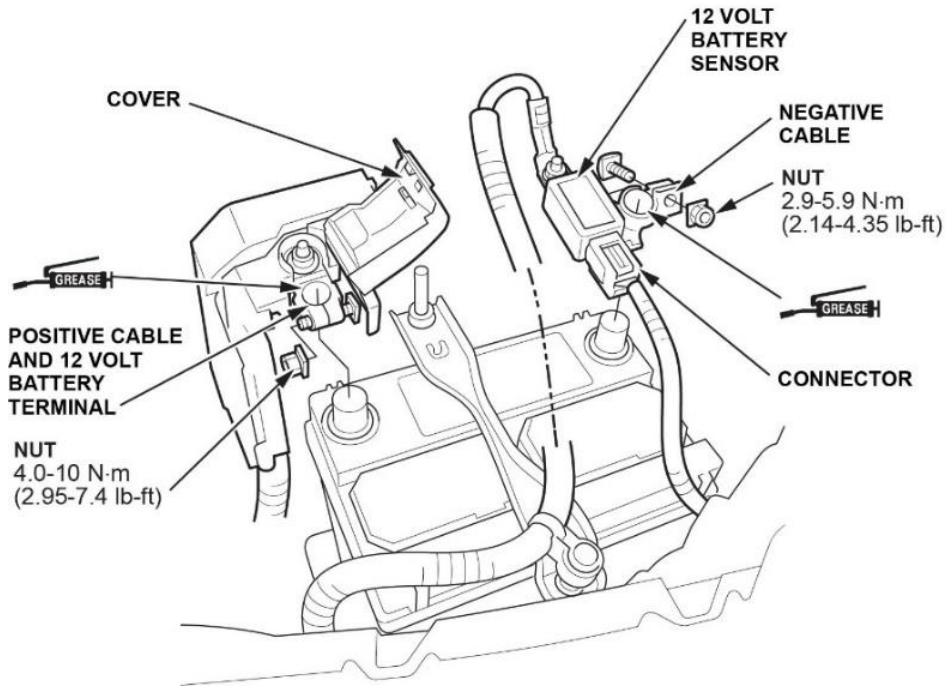

2.5. Remove the harness clip and connectors as shown.

NOTE: The manual seat is shown below, the power seat is similar.

**DRIVER'S SEAT (WITHOUT SEAT POSITION SENSOR)**

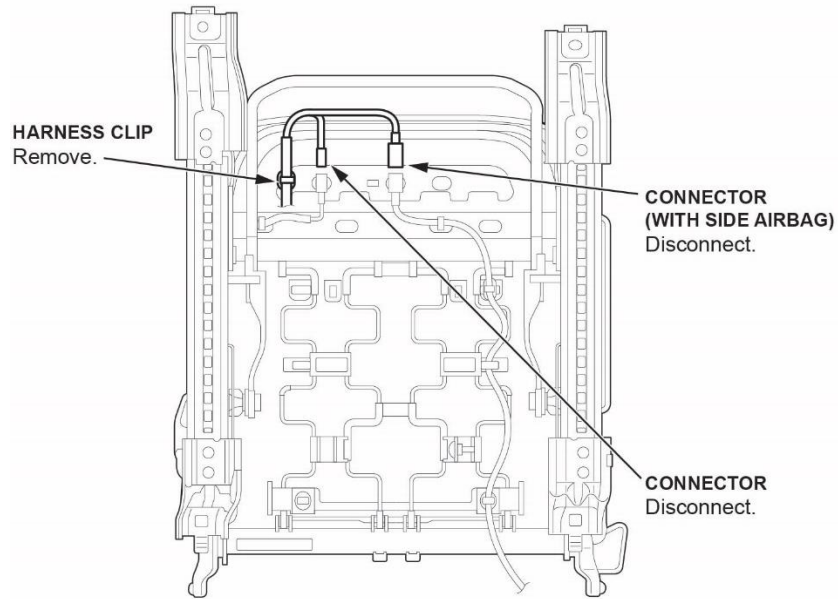

**DRIVER'S SEAT (WITH SEAT POSITION SENSOR)**

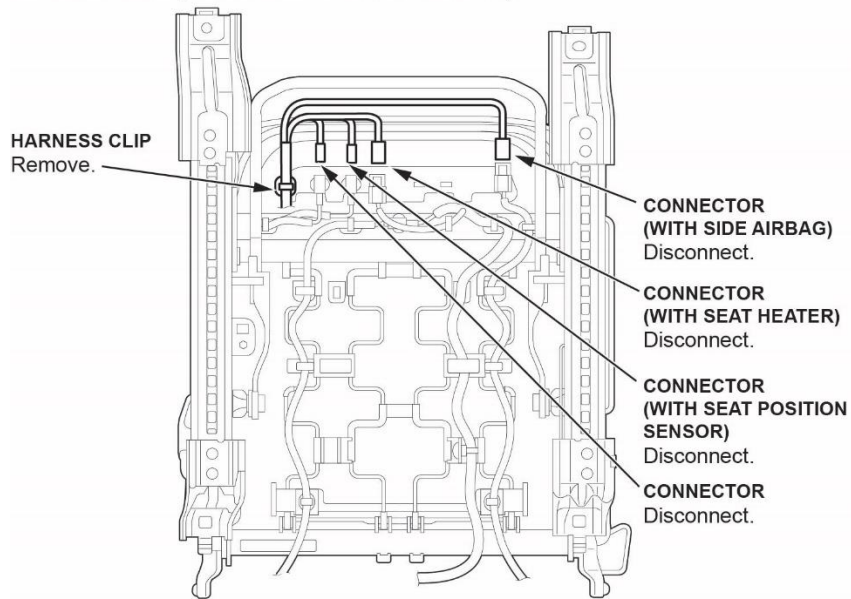

3. Remove the rear heater duct.

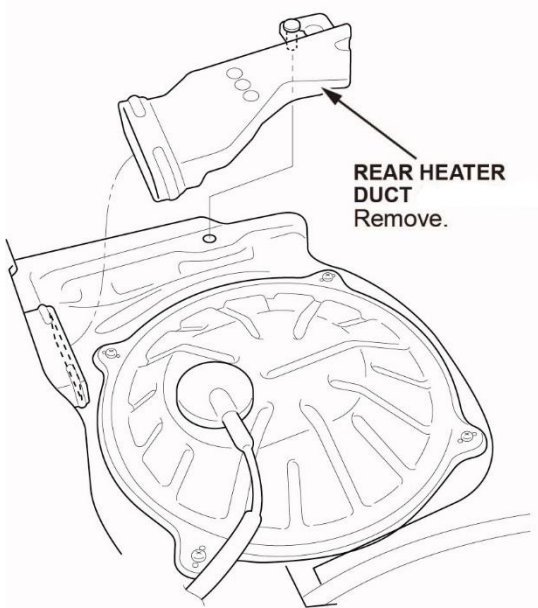

4. Remove the fuel tank unit access panel, and disconnect the connector.

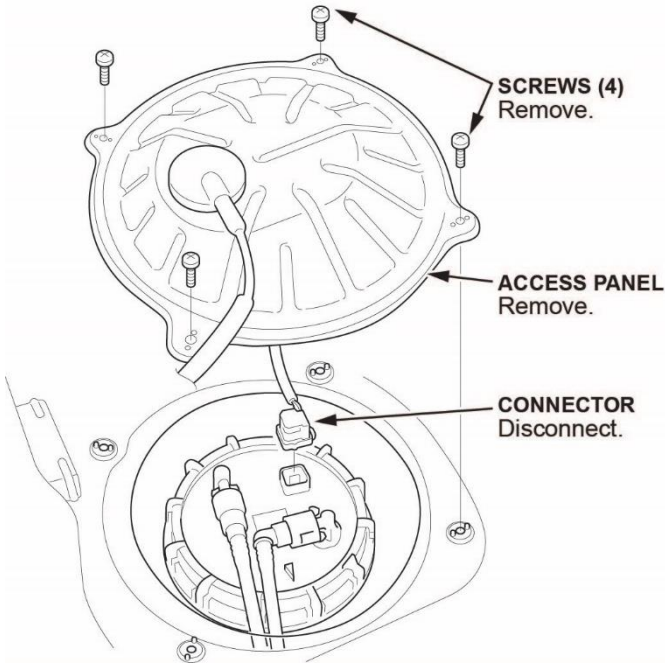

5. Place a rag or shop towel over the quick-connect fittings, and disconnect them.

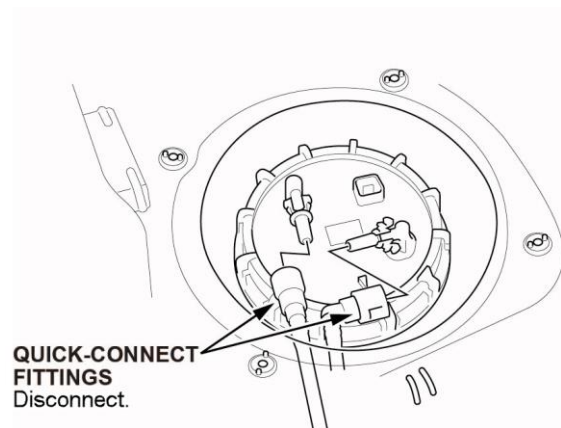

6. Loosen the fuel tank unit locknut using the Fuel Sender Wrench (T/N 070AA-T0AA100 or 07AAA-T0AA100), then remove it.

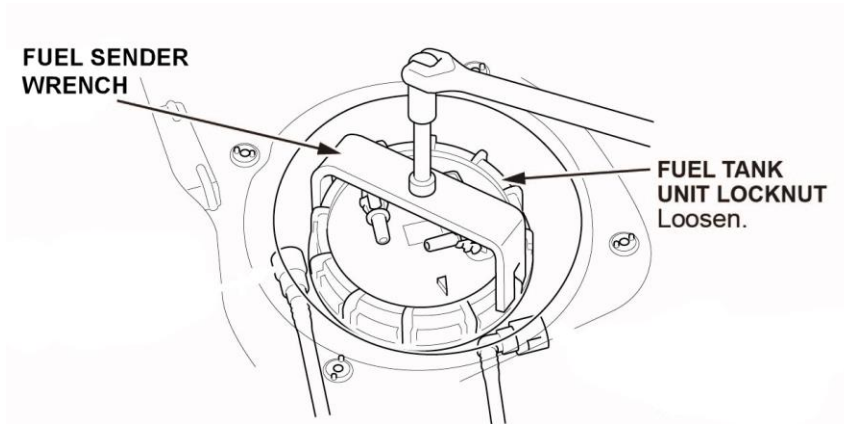

7. Lift the fuel tank unit, and disconnect the transfer tube. Then, remove the fuel tank unit.

**NOTE:**

- After unlocking the fuel tank unit cam lock ring, clean the top of the fuel pump flange and adjacent areas to make sure it's free of dirt, dust, and debris.
- Make sure not to bend or twist the fuel level sensor arm excessively.

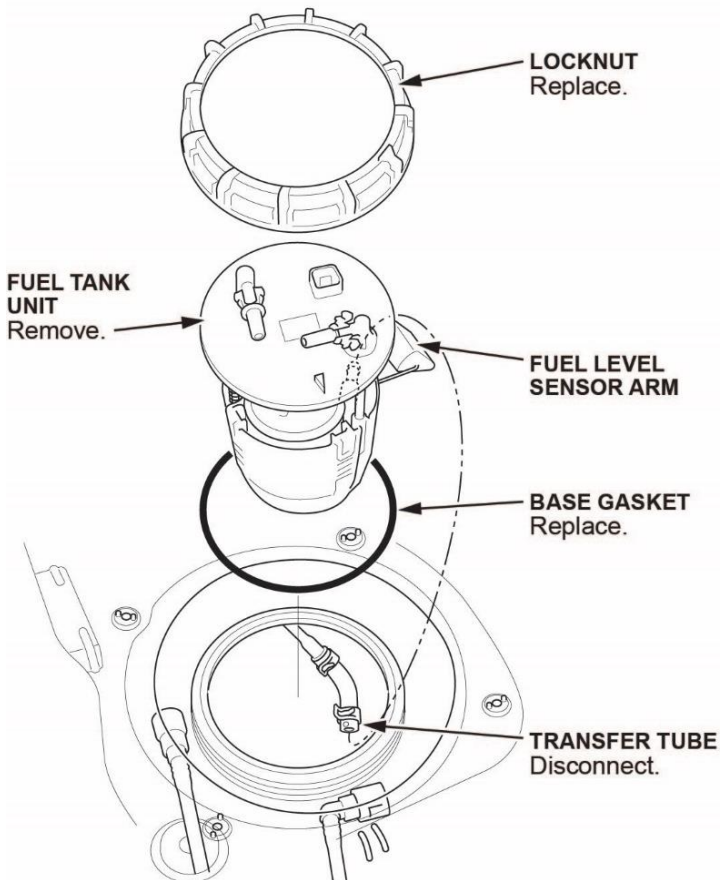

8. Disassemble the fuel tank unit.

8.1. Prepare the fuel tank unit and parts to be replaced.

NOTE: Take a photo of the fuel tube and wire harness, and note their routing for assembly. There are various types of routing.

8.2. Spread the wire harness clamps, and remove the wire harness. Make sure not to damage the wire harness.

NOTICE

Do not spread the clamps too wide. Spreading them too wide may damage them.

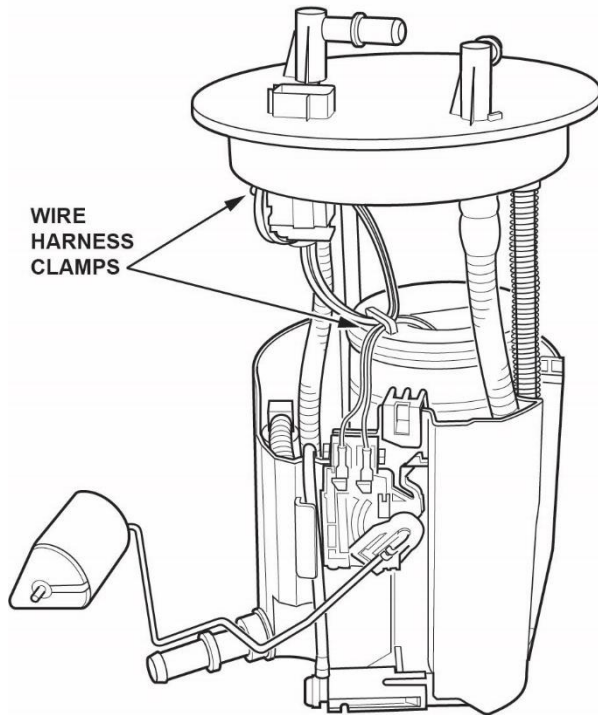



8.3. Remove the fuel level sensor.

- Disconnect the harness.

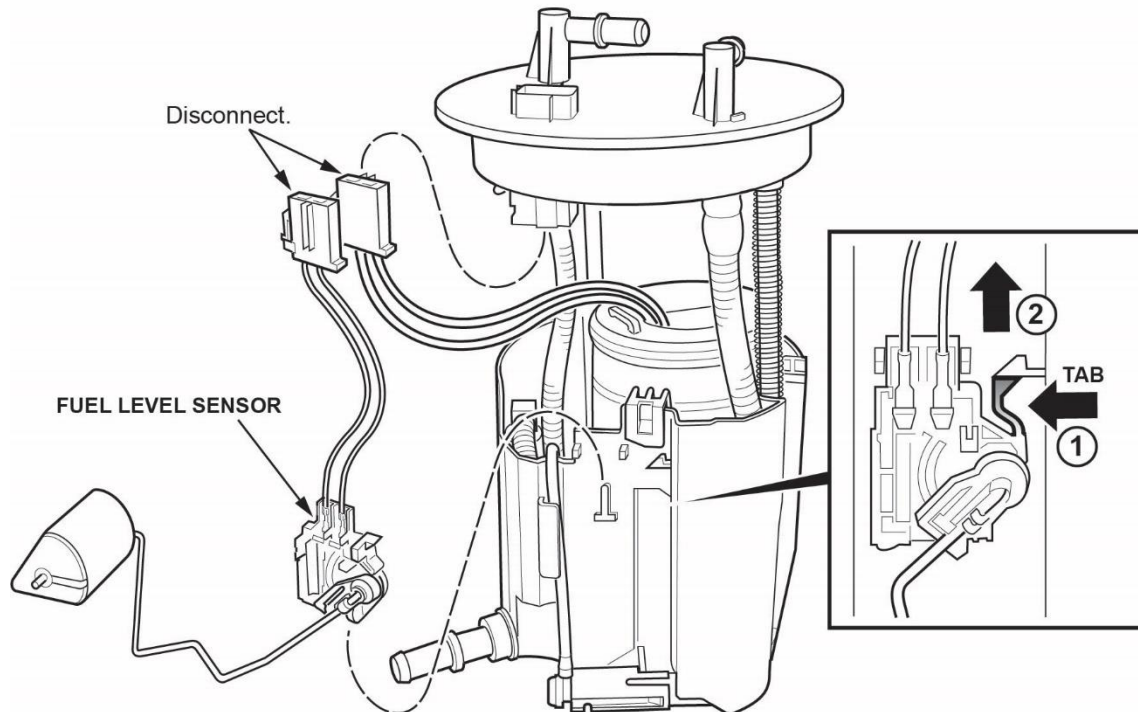

- Press the tab to release the lock (1). Then, push up on the fuel gauge sending unit (2).
- Remove the fuel level sensor from the fuel tank unit.

8.4. Remove the E-ring, and throw it away. Do not use it again.

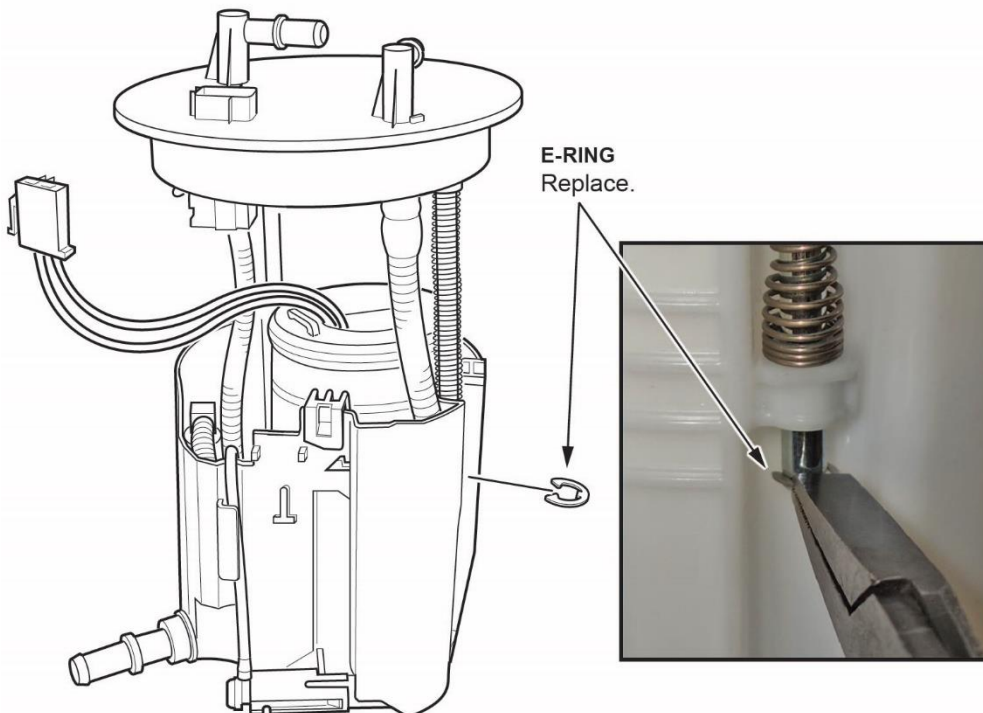

8.5. Use an O-ring pick to disconnect joint A inside the reservoir.

NOTE: If the O-ring remains inside the joint, use a flat-tip screwdriver wrapped in protective tape to remove it. Take care not to damage the O-ring seat section.

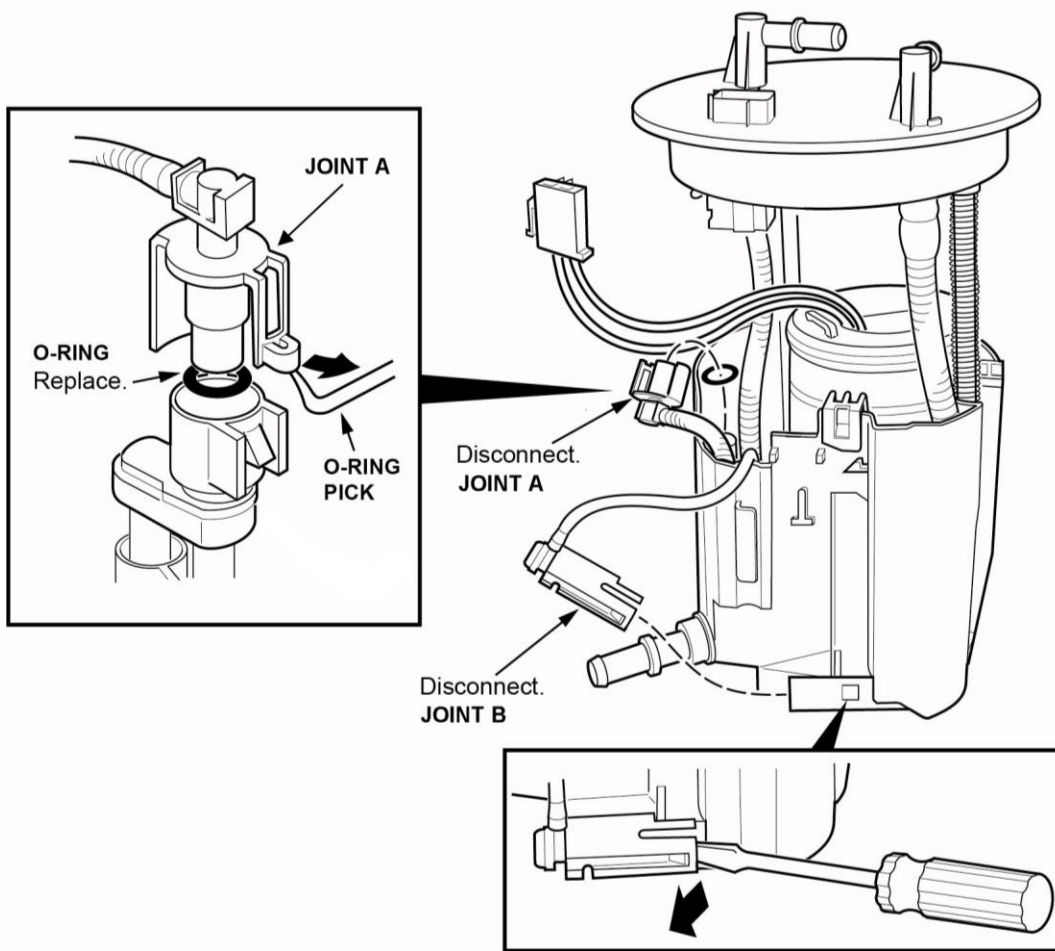

8.6. Disconnect joint B from the bottom of the reservoir.

8.7. Remove the fuel filter assembly from the reservoir by releasing the three clips.

NOTE: The spring may slide off the sliding shaft. Retain this spring. It will be used during assembly.

**NOTICE**

Do not spread the clips too wide. Spreading them too wide may damage them.

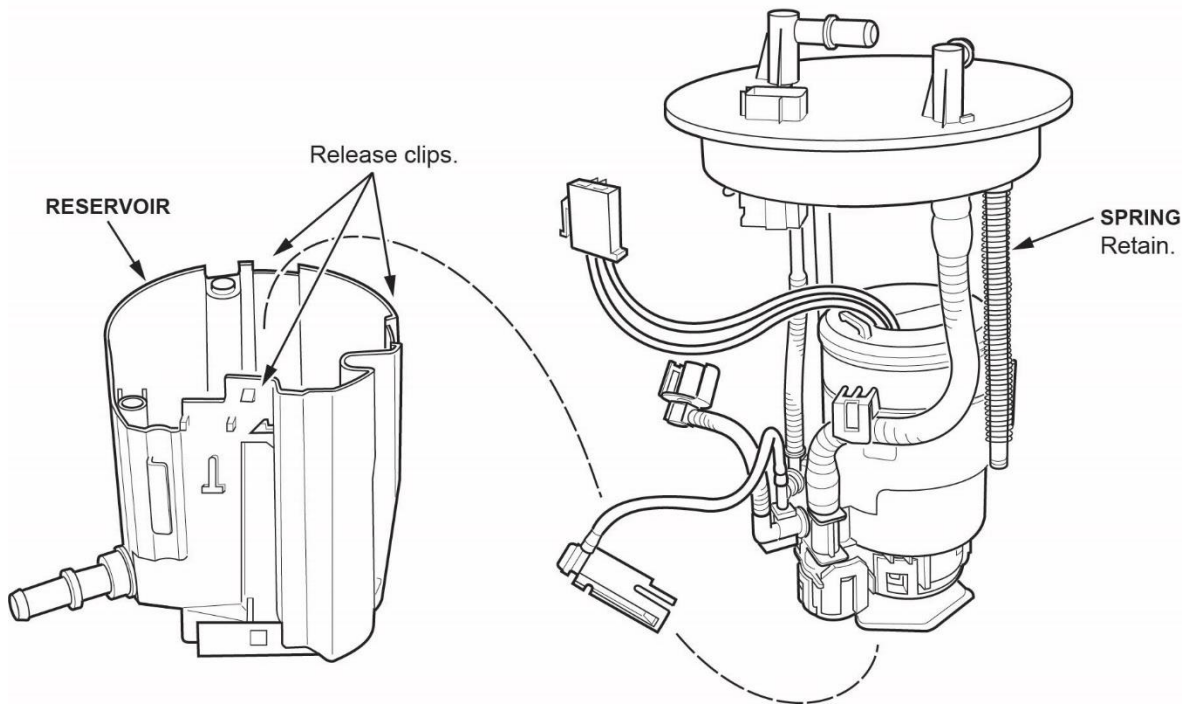

8.8. Remove the fuel pump assembly from the fuel filter.

- Release the three clips at the base of the fuel pump assembly.
- Pull the fuel pump assembly out of the fuel filter.
- If the O-ring remains on the fuel filter, use a flat-tip screwdriver wrapped in protective tape to remove it. Take care not to damage the O-ring seat section.

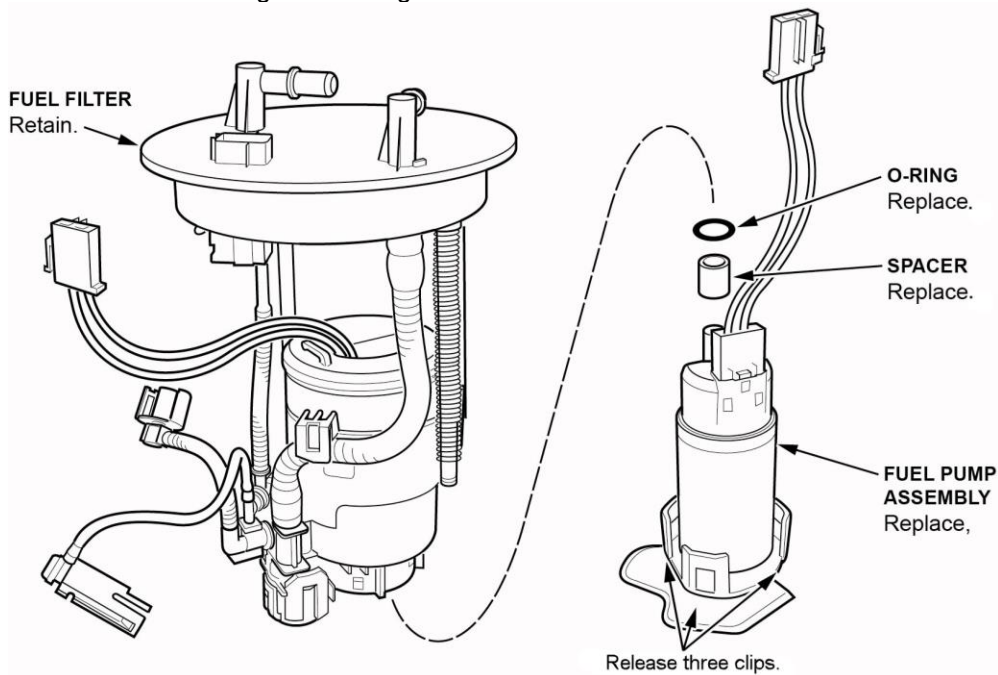

9. Assemble the fuel tank unit.

9.1. Install the new spacer on the new fuel pump motor.

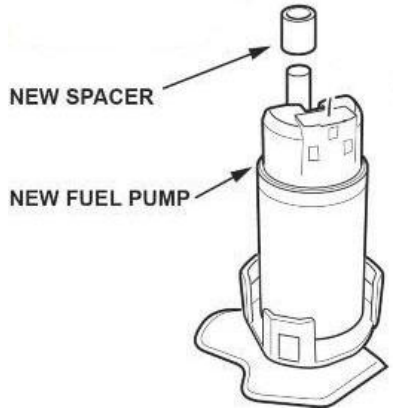

9.2. Install the new O-ring, then lubricate the outside edge of it, using only clean engine oil.

**NOTE:** Do not pinch the O-ring during installation.

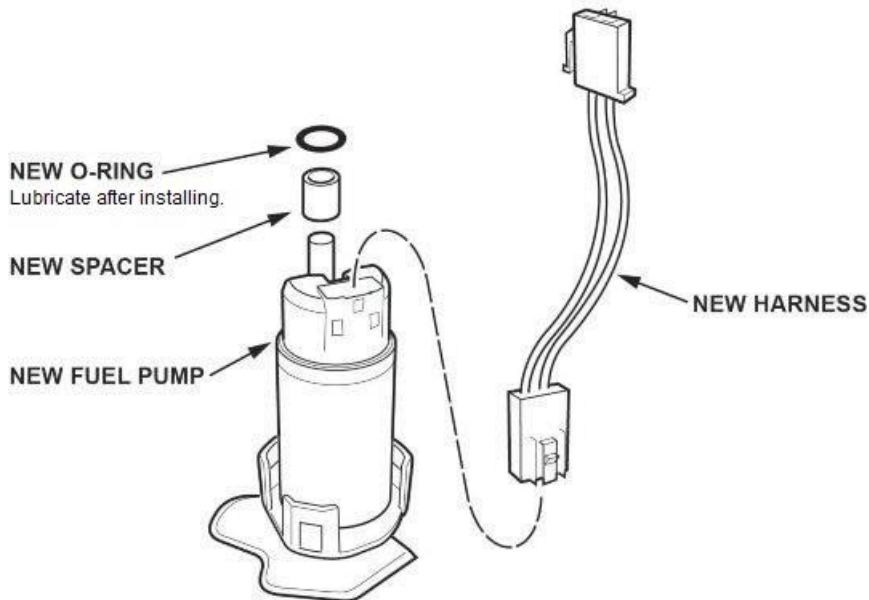

9.3. Install the new harness and make sure the connection is secure and the connectors are firmly locked into place.

9.4. Place the fuel pump on a bench, then install the filter to the fuel pump.

**NOTE:** If the fuel pump does not engage into the fuel filter and re-insertion is necessary, confirm that the O-ring is seated on the fuel pump before repeating installation.

9.5. Install the fuel filter assembly to the reservoir.

- Install a new O-ring on joint A before connecting it.
- Coat the O-ring with clean engine oil; do not use any other oil or fluid.
- Do not pinch the O-ring during installation.
- Install the spring into the sliding shaft, and make sure it is lined up when installing the fuel filter.

NOTE:

- Make sure the fuel tube is routed **exactly** as shown in the photo taken before disassembly.
- Make sure the three clips are fully engaged.

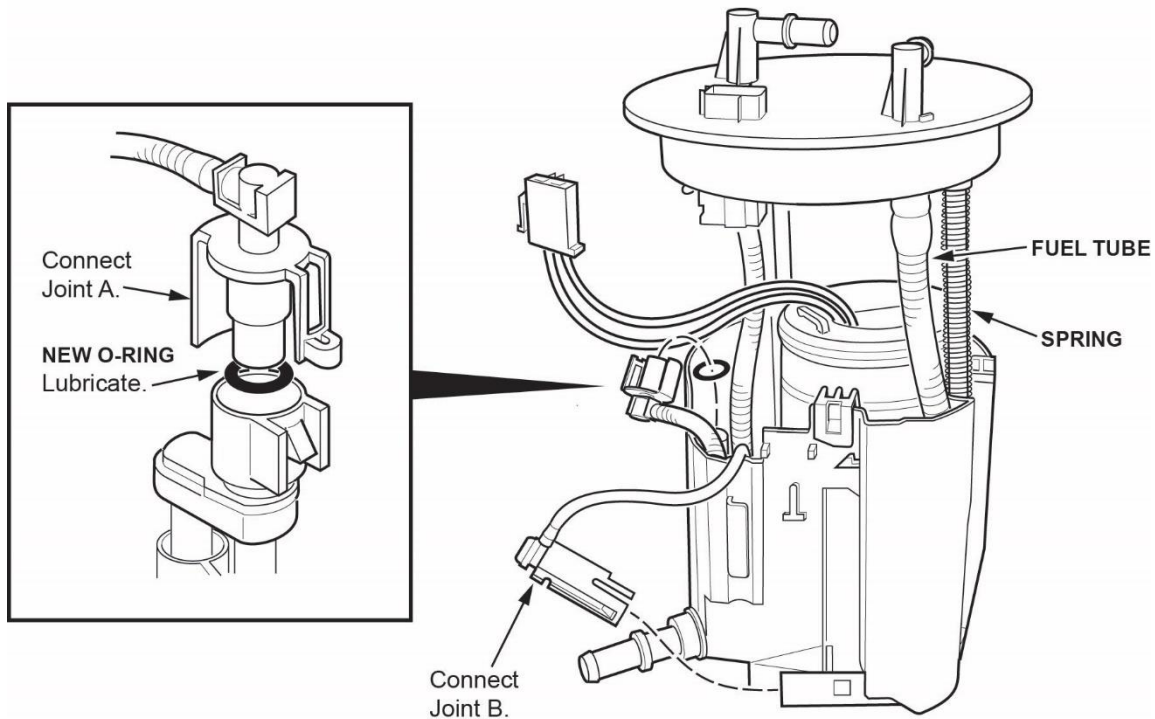

9.6. Connect joint B.

9.7. Install the new E-ring.

NOTE: After installation, make sure the E-ring can be rotated with your finger. If it cannot be rotated, the E-ring may not be fully seated or may be incorrectly installed.

9.8. Install the fuel level sensor to the reservoir. Make sure the lock is engaged.

NOTE: When installing the fuel level sensor, make sure the connection is secure and the connector is firmly locked into place. Be careful not to bend or twist it excessively.

9.9. Install the wiring harness to the clamps.

NOTE:

- Clip in the smaller harness wires followed by the larger wires.
- Make sure not to damage the wire harness.
- Make sure the wire harness is routed **exactly** as shown in the photo taken before disassembly.
- Do not spread the clamps too wide. Spreading them too wide may damage them.

**HARNESS ROUTING**

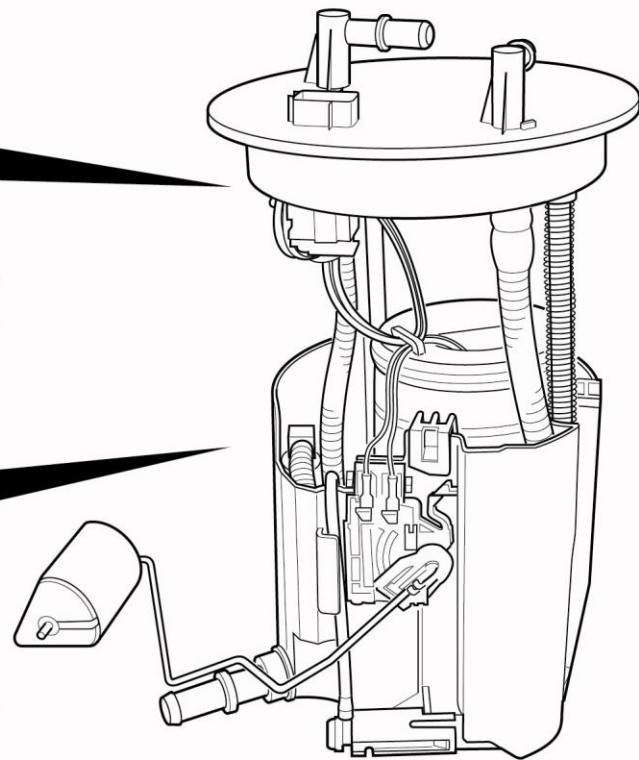
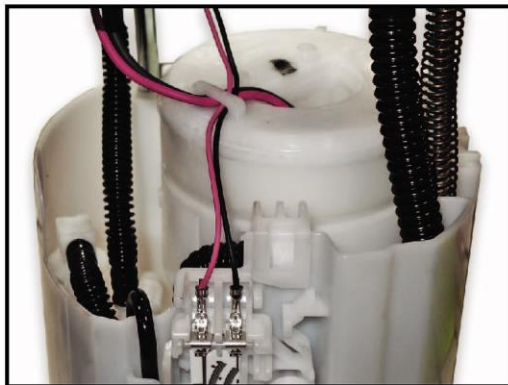
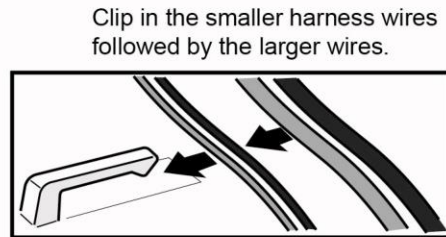

9.10. While compressing the fuel tank unit, make sure the movement is smooth and the fuel tube and wiring harness do not pinch or bind.

- Make sure the wire harness is not stretched.
- Make sure the fuel tube is not pinched.

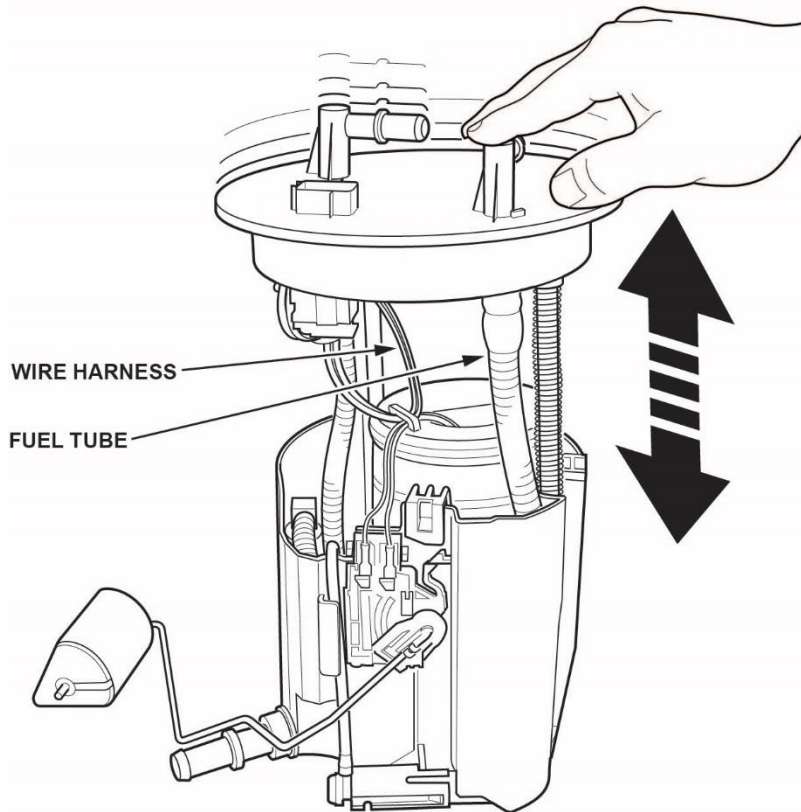

10. Install the fuel tank unit.

10.1. Clean the seal surfaces on the fuel tank unit and gasket groove on the fuel tank.

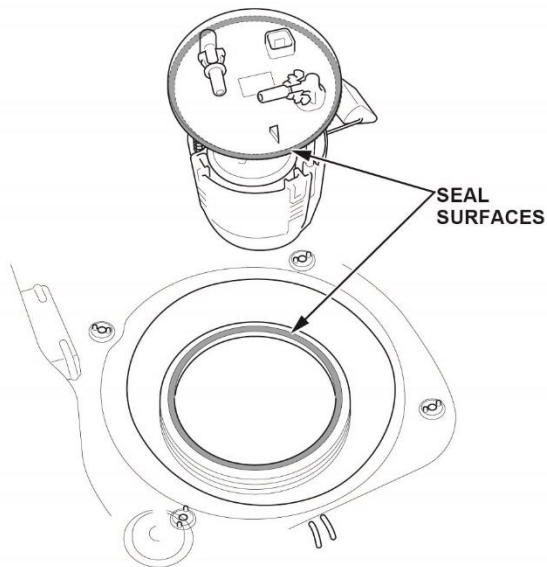

10.2. Carefully install a new base gasket to the gasket groove on the fuel tank as shown.



BASE GASKET

FUEL TANK

10.3. Connect the transfer tube to the fuel tank unit.

NOTE: Make sure the transfer tube clamp is positioned as shown.

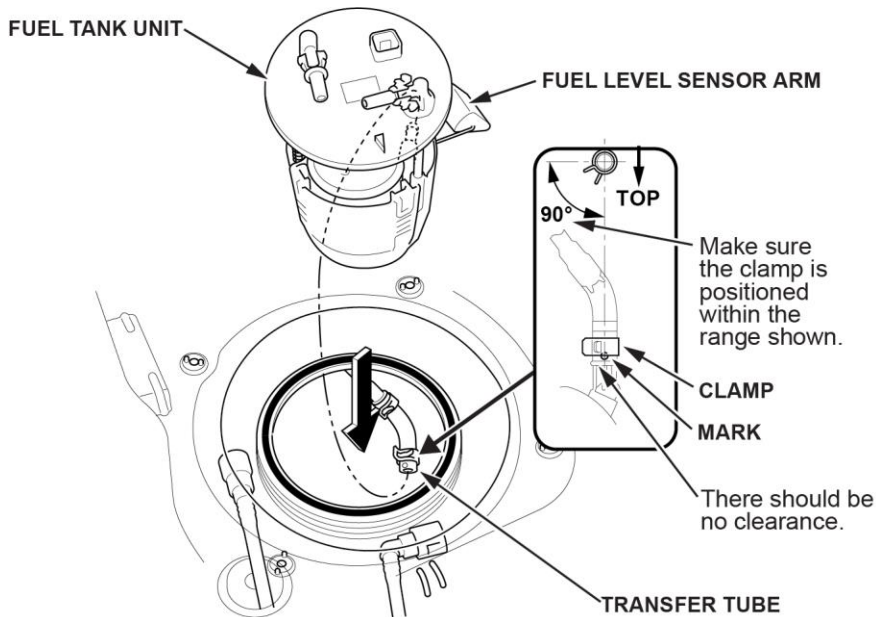

FUEL TANK UNIT

FUEL LEVEL SENSOR ARM

90°

TOP

Make sure the clamp is positioned within the range shown.

CLAMP

MARK

There should be no clearance.

TRANSFER TUBE

10.4. Partially insert the fuel tank unit into the fuel tank.

NOTE:

- Before installing the new O-ring, clean the fuel tank around the fuel pump opening where the O-ring will seat. The tank opening must be free of dirt, dust, and debris.
- Be careful not to damage the new base gasket.
- Do not coat the base gasket with any oil.
- Make sure not to bend or twist the fuel level sensor arm excessively.



10.5. Line up the marks on the fuel tank and fuel tank unit as shown, then insert the fuel tank unit.

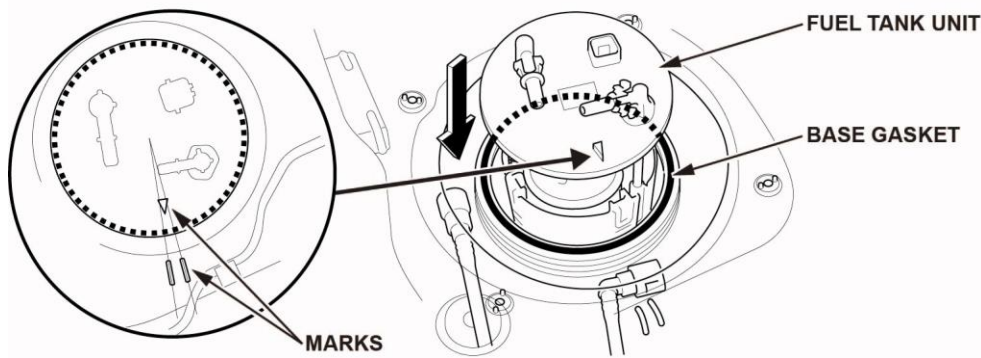

10.6. While pushing down the fuel tank unit, make sure the fuel tank unit is flat against the base gasket. To avoid a fuel leak and/or damaging the gasket, make sure the base gasket is not pinched. Do this either visually and/or by hand.

10.7. Push down firmly on the locknut at the 3 o'clock mark to make sure the threads on the fuel tank opening are properly engaged.

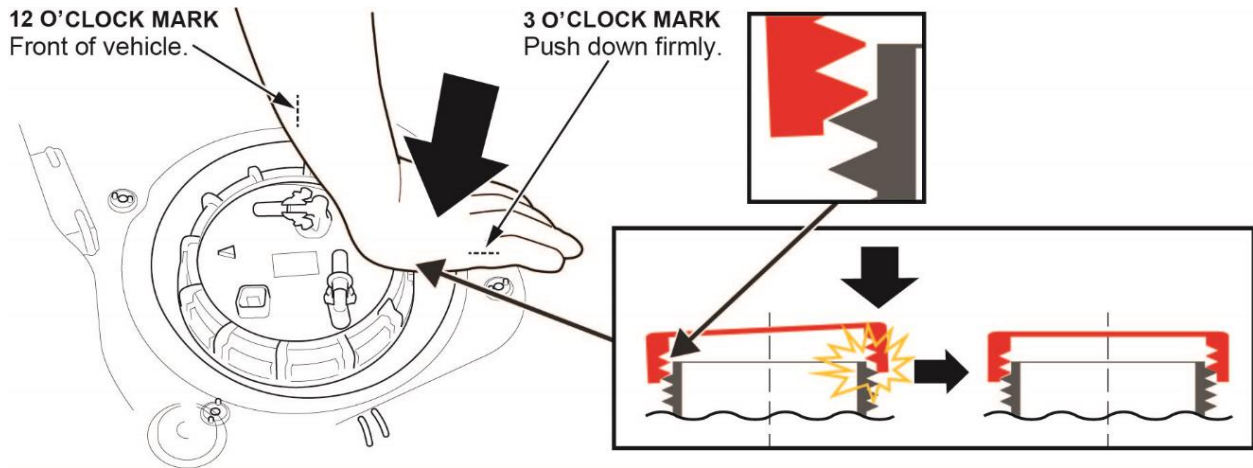

10.8. Rotate the locknut clockwise 195 degrees from the thread starting point.

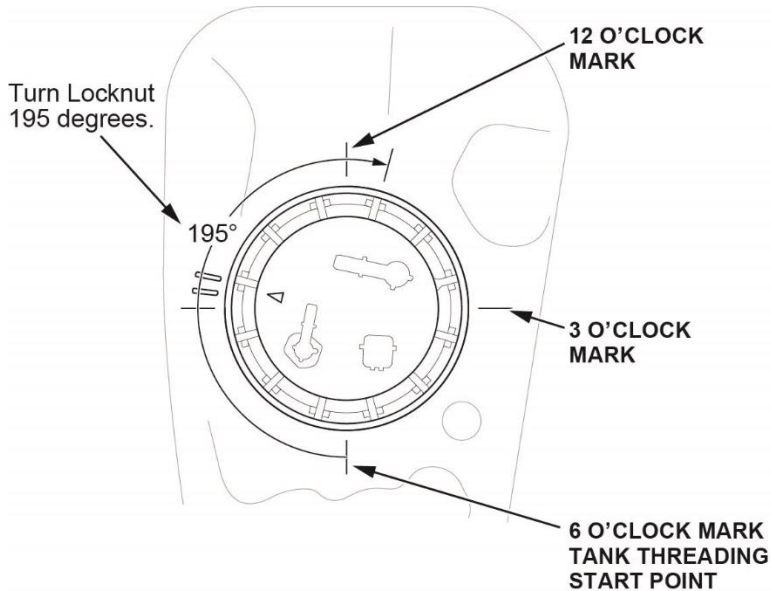

11. Tighten the fuel tank unit locknut.

**NOTICE**

If the locknut is not properly installed, the fuel tank can be damaged and will require replacement.

11.1. While pushing down the fuel tank unit, tighten the new fuel tank unit locknut with a new locknut plate by hand.

11.2. Tighten the fuel tank unit locknut to the specified torque using the fuel sender wrench.

NOTE: After tightening, make sure the marks are still lined up.

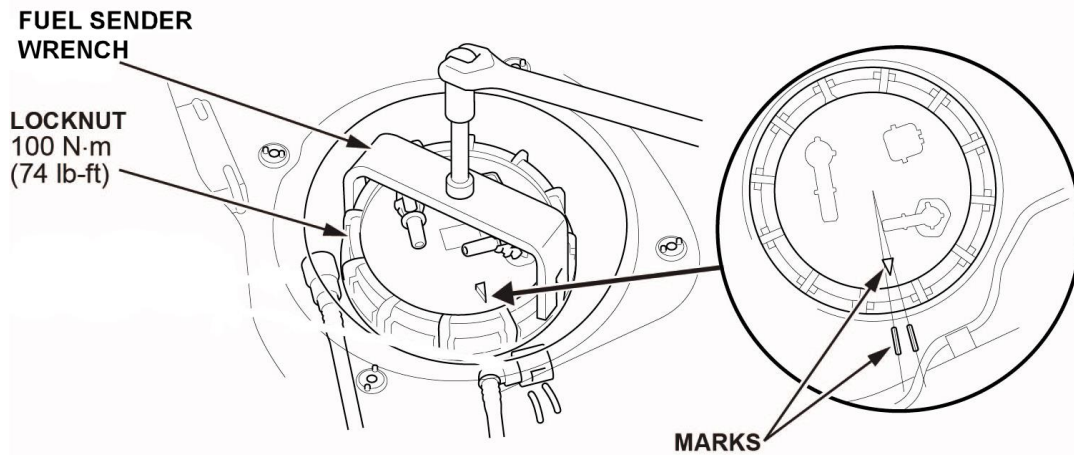

12. Remove the quick-connect fitting retainers on the fuel tank unit, then install the new retainers to the quick-connect fittings as shown.

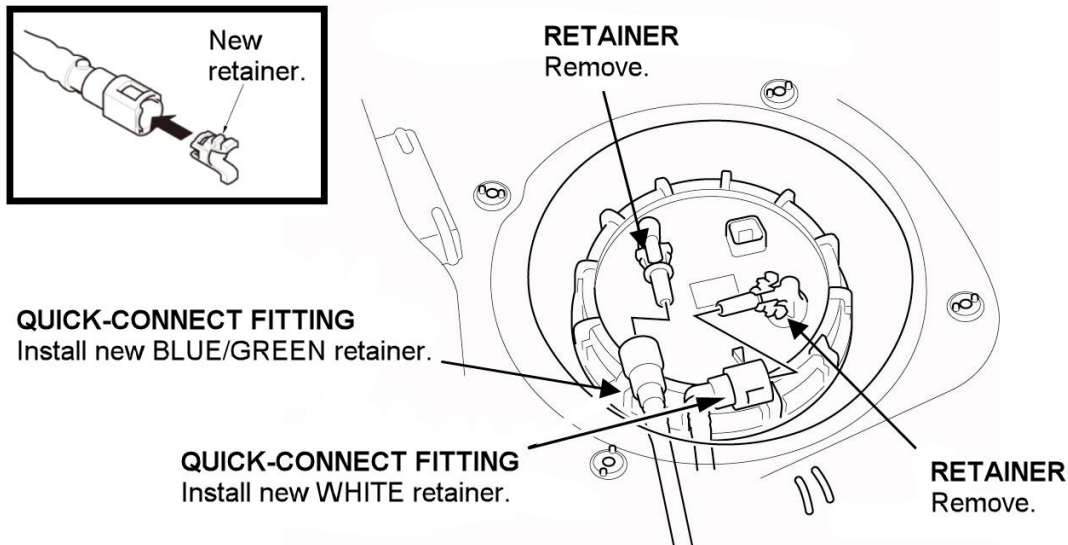

13. Connect the quick-connect fittings to the fuel tank unit.

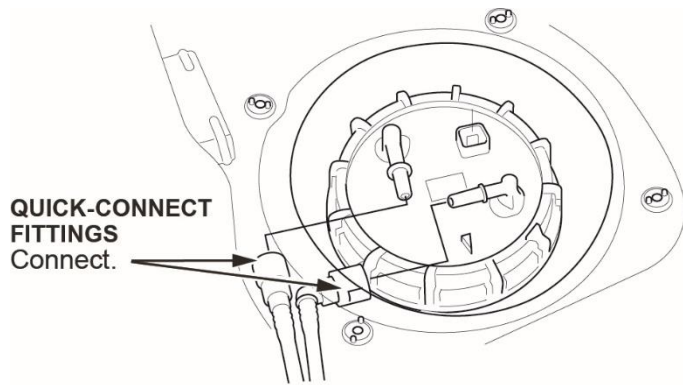

14. Connect the fuel tank unit connector.

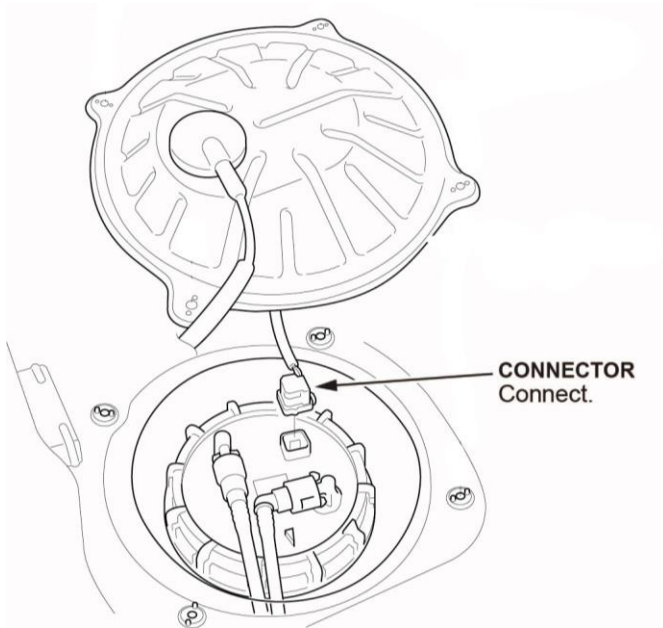

15. Connect the 12-volt battery terminals.

16. Check for fuel leaks by turning the ignition to ON, but do not turn the engine on. After the fuel pump runs for about **2 seconds**, the fuel line will be pressurized. Repeat this two or three times, then make sure there is no fuel leakage.

17. Install the fuel tank unit access panel.

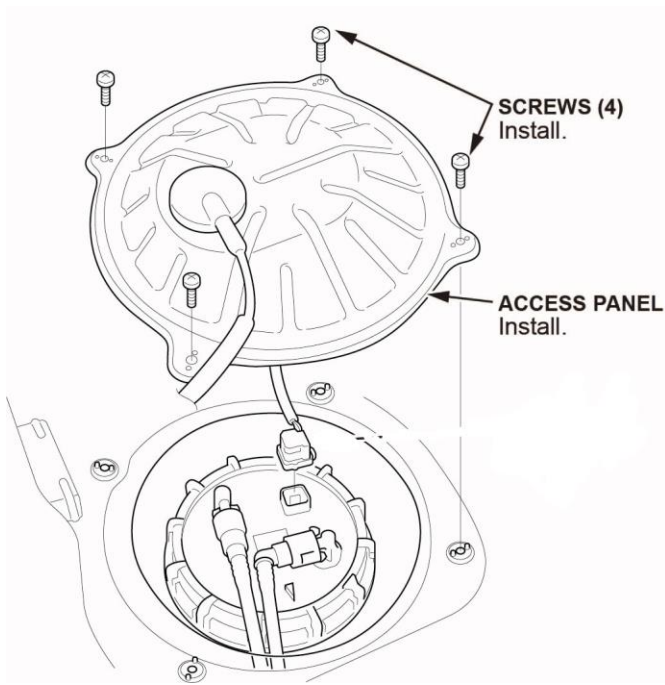

18. Install the remaining parts in the reverse order of removal.

19. Clear all DTCs using an i-HDS.

20. *California residents only:* Fill out a Vehicle Emissions Recall – Proof of Correction certificate, and use **K7X** as the recall number. Have the service advisor give the certificate to your customer, and advise him or her to keep it as proof that the recall was completed. Your customer will need to submit this certificate to the DMV only if the DMV requests it. If you need more certificates, use reorder number **Y0657**.

**Vehicle Emission Recall - Proof of Correction**

License Number	Make	Year Model	Body Type	Vehicle Identification Number

Manufacturer \_\_\_\_\_ Recall Number **K7X**

The above described vehicle has been repaired, modified and/or equipped with new emission control devices to meet applicable California Emission Control Laws.

Dealer's Name \_\_\_\_\_ Address, City, State and Zip \_\_\_\_\_

Date \_\_\_\_\_ Dealership's Authorized Signature \_\_\_\_\_

X

Return this certificate to DMV only when required - otherwise retain for your records.

Y0657 ACL 24832 (0212)

END