

July 30, 2021

Version 3

Safety Recall: 2018-19 Accord Fuel Pump MotorSupersedes 20-043, dated June 19, 2020, to revise the information highlighted in **yellow**.**AFFECTED VEHICLES**

Year	Model	Trim Level	VIN Range
2018-19	Accord	2.0L	Check the iN VIN status for eligibility.

REVISION SUMMARY

Under REPAIR PROCEDURE, steps 6.2, 7, 9.1, 9.2 and 9.3 were revised.

BACKGROUND

Due to swelling of the fuel pump motor impeller, the fuel pump may seize and stop working. If this occurs, the engine may not start, or the engine could stall while driving, increasing the risk of a crash.

CUSTOMER NOTIFICATION

Owners of affected vehicles will be sent a notification of this campaign.

Do an iN VIN status inquiry to make sure the vehicle is shown as eligible.

Some vehicles affected by this campaign may be in your new or used vehicle inventory.

Failure to repair a vehicle subject to a recall or campaign may subject your dealership to claims or lawsuits from the customer or anyone else harmed as a result of such failure. To see if a vehicle in inventory is affected by this safety recall, do a VIN status inquiry before selling it.

CORRECTIVE ACTION

Replace the fuel pump motor.

CUSTOMER INFORMATION:The information in this bulletin is intended for use only by skilled technicians who have the proper tools, equipment, and training to correctly and safely maintain your vehicle. These procedures should not be attempted by "do-it-yourselfers," and you should not assume this bulletin applies to your vehicle, or that your vehicle has the condition described. To determine whether this information applies, contact an authorized Honda automobile dealer.

PARTS INFORMATION

NOTE: Due to limited supply, this will be a controlled part and will require a valid VIN when ordering.

Part Name	Part Number	Quantity
Fuel Pump Motor Kit	06170-TVC-306	1

For dealers experiencing a strong fuel smell from storing a fuel pump motor replaced under this service bulletin, the fuel pump motor may be disposed of immediately in accordance with local regulations. This only applies to the fuel pump motor replaced under this service bulletin. The published retention policy remains in effect for all other parts. If you have any questions about this exception or other parts retention issues, contact the WPI Administrative Office at **937-642-2737**.

TOOL INFORMATION

Part Name	Tool Number	Quantity
Fuel Sender Wrench	070AA-TLA0100	1

WARRANTY CLAIM INFORMATION

Operation Number	Description	Flat Rate Time	Defect Code	Symptom Code	Template ID	Failed Part Number
3101HK	Replace the fuel pump motor.	1.2 hr	6FE00	F7I00	A20043A	17045-TVC-A03

REPAIR PROCEDURE

⚠ WARNING

Fuel pump motor removal exposes fuel, which can ignite, causing a fire or explosion.

This can cause serious injury or death.

Always work in a well-ventilated area and keep sparks or open flames away.

1. Relieve the fuel pressure.
 - 1.1. Insert the emergency fuel fill funnel into the fuel filler neck to relieve the pressure in the fuel tank.
- NOTE: The emergency fuel fill funnel is in the trunk tool box.

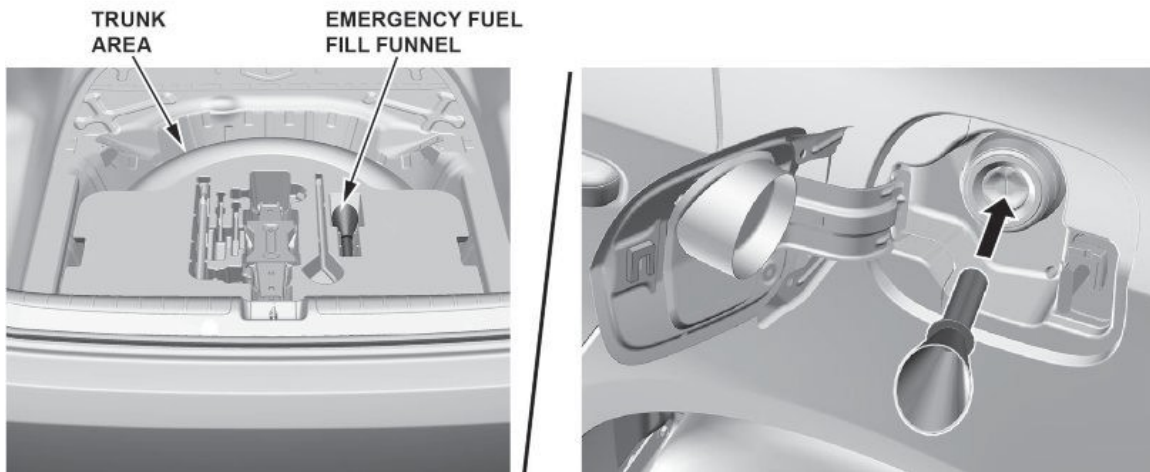

1.2. Remove PGM-FI main relay 2.

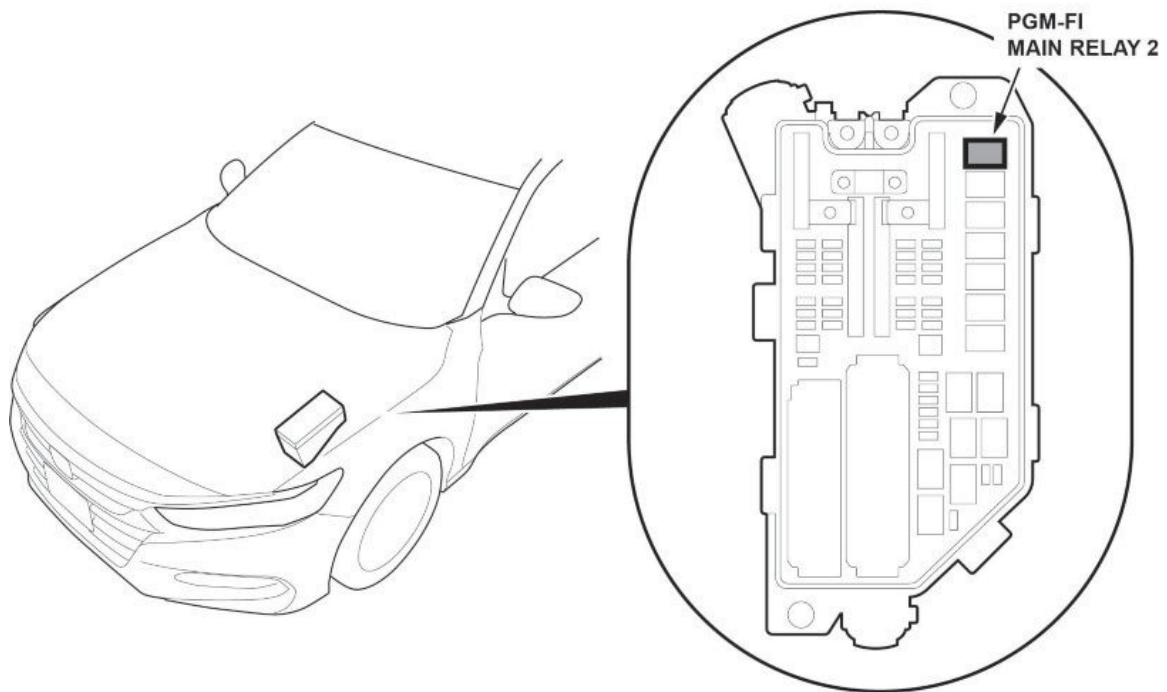

1.3. Start the engine, and let it idle until it stalls.

1.4. Turn the ignition to OFF.

1.5. Install PGM-FI main relay 2.

2. Disconnect both 12-volt battery terminals.

NOTE:

- Always disconnect the negative terminal first.
- To protect the terminal connector from damage, do not hold it when removing the terminal.
- Do not disconnect the 12-volt battery sensor from the cable.

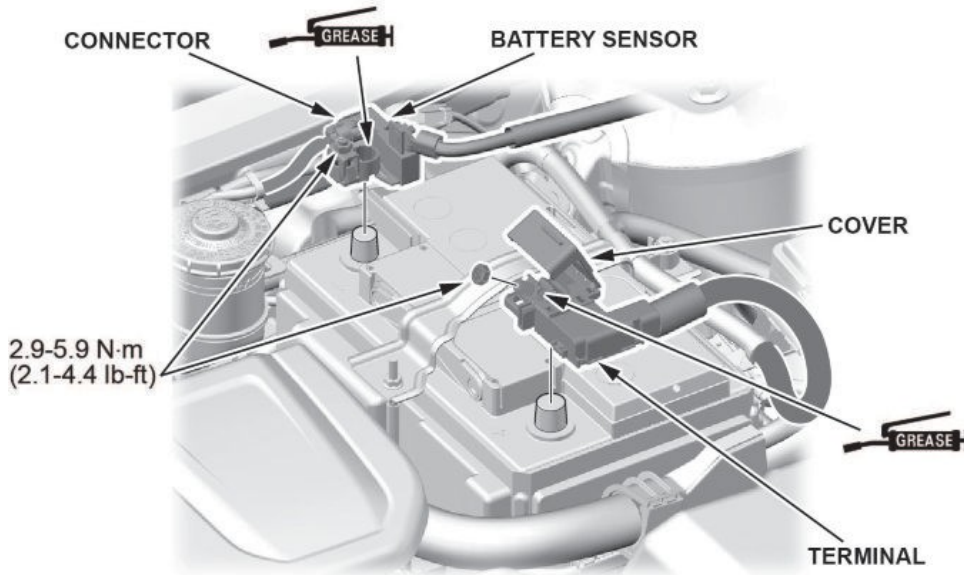

3. Remove the rear seat cushion.

3.1. Remove the trunk floor cover.

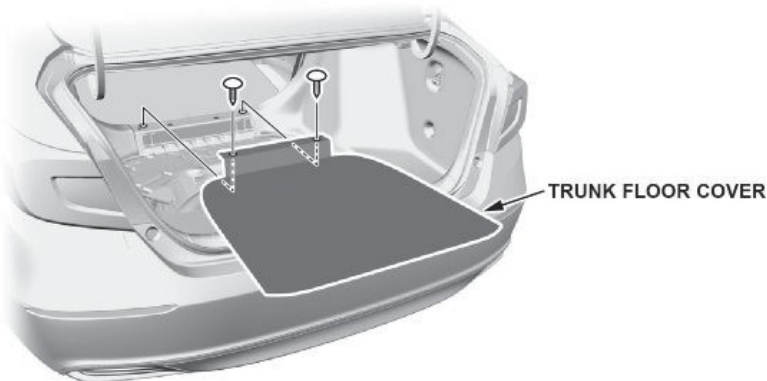

3.2. Fold down the left and right-rear seat-backs.

3.3. Remove the clip, then turn over the rear seat-back cover.

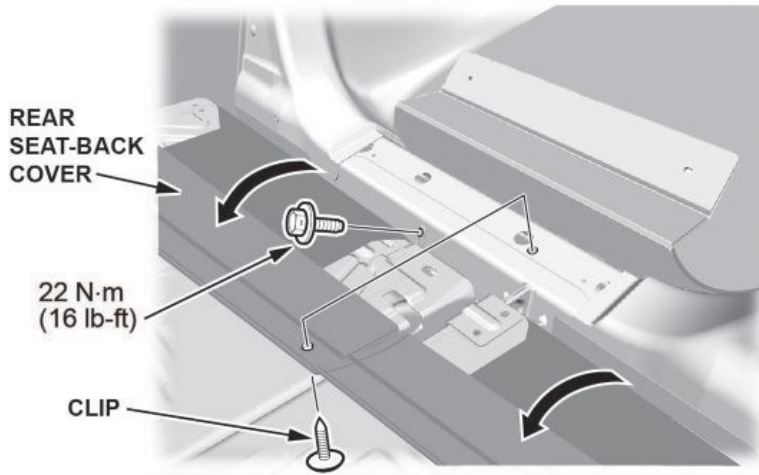

3.4. Remove the bolt.

3.5. Fold up the left and right-rear seat-backs.

3.6. While pushing down on the seat cushion, pull the seat hook handles to release the hooks.

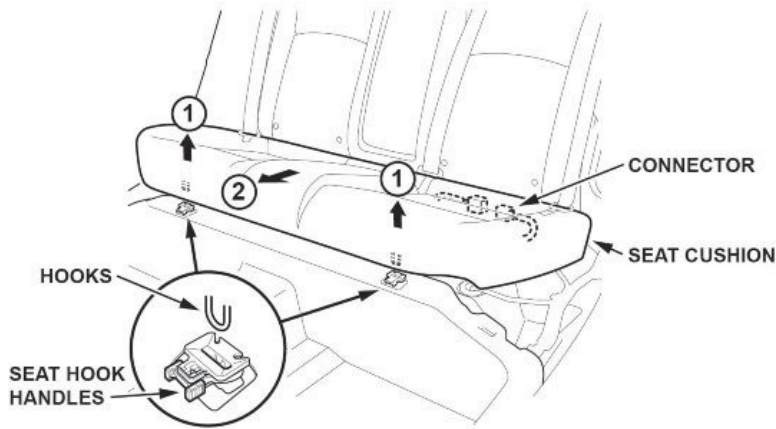

3.7. *With rear seat heaters:* Disconnect the connector.

3.8. Remove the rear seat cushion.

4. Remove the fuel tank unit access panel and connector.

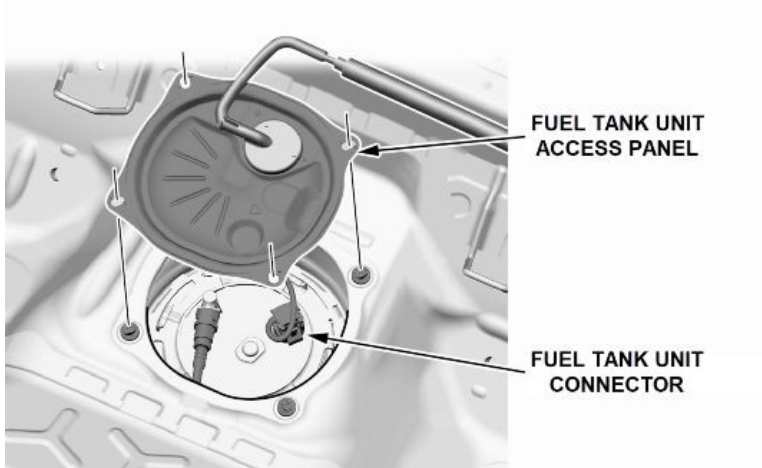

5. Place a rag or shop towel over the quick-connect fitting, and disconnect it.

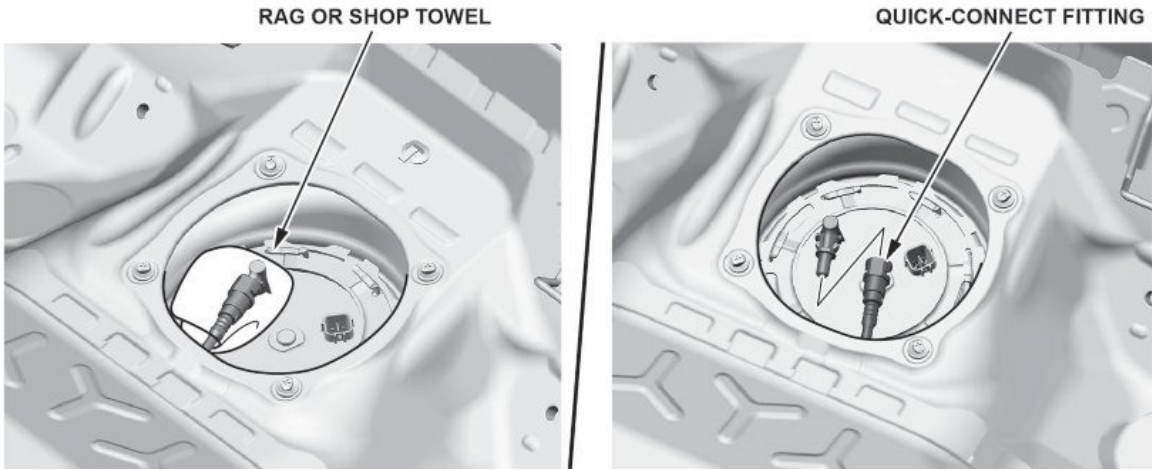

6. Unlock the fuel tank unit cam lock ring using the fuel sender wrench (070AA-TLA0100).

6.1. Set the fuel sender wrench as shown.

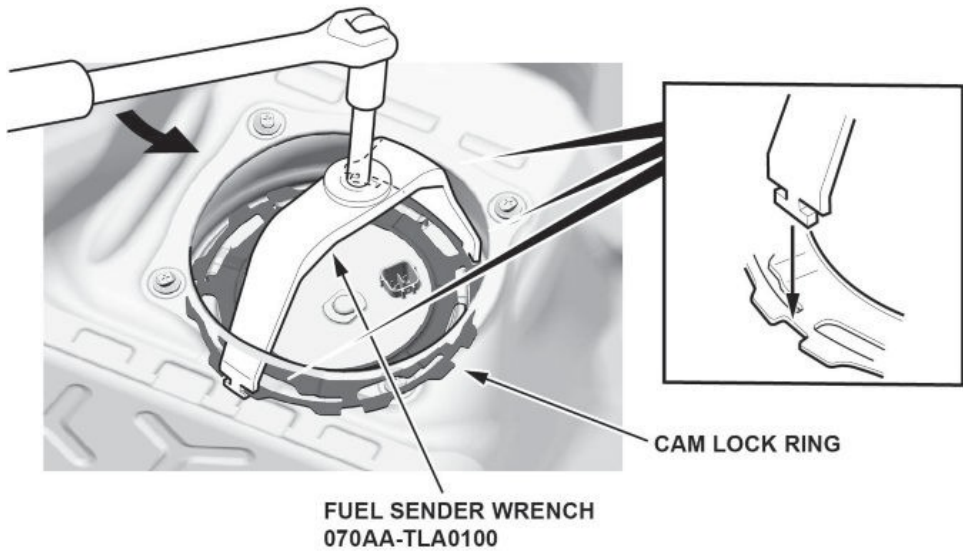

6.2. Turn the fuel tank unit cam lock ring counterclockwise.

NOTE: After unlocking the fuel tank unit cam lock ring, clean the top of the fuel pump flange and adjacent areas to make sure it's free of dirt, dust, and debris.

7. Remove the fuel tank unit.

NOTE:

- After removing the fuel pump unit, clean the fuel tank around the fuel pump opening.
- After removing the fuel pump O-ring, clean the fuel tank around the O-ring opening and make sure it's free of dirt, dust, and debris.

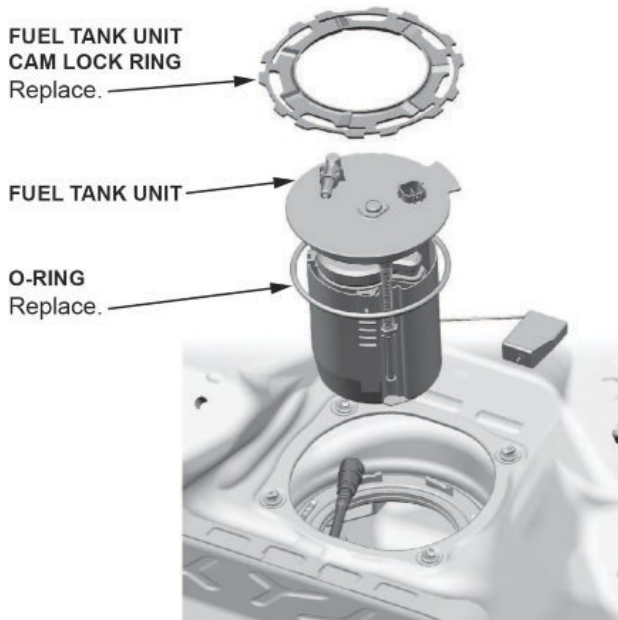

8. Disassemble the fuel tank unit.

8.1. Prepare the fuel pump and parts to be replaced.

NOTE: Take a photo of the fuel tube and wire harness, and note their routing for assembly. There are various types of routing.

8.2. Spread the wire harness clamps, and remove the wire harness.

NOTE:

- Make sure not to damage the wire harness.
- Do not spread the clamps too wide. Spreading the clamps too wide may damage them.

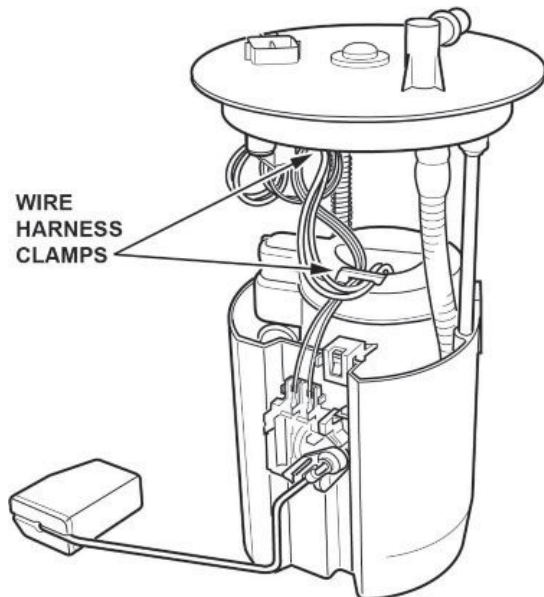

8.3. Remove the fuel level sensor.

- Disconnect the harnesses.

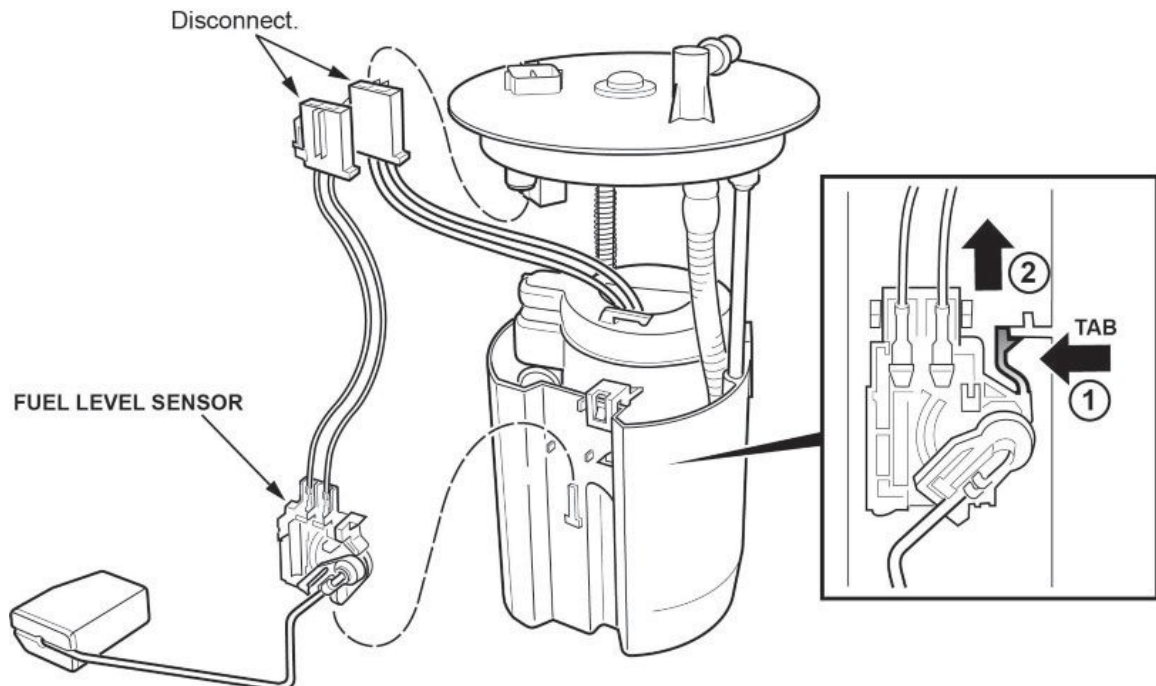

- Press the tab to release the lock (1). Then, push up on the fuel gauge sending unit (2).
- Remove the fuel level sensor from the fuel tank unit.

8.4. Remove the E-ring, and throw it away. Do not use it again.

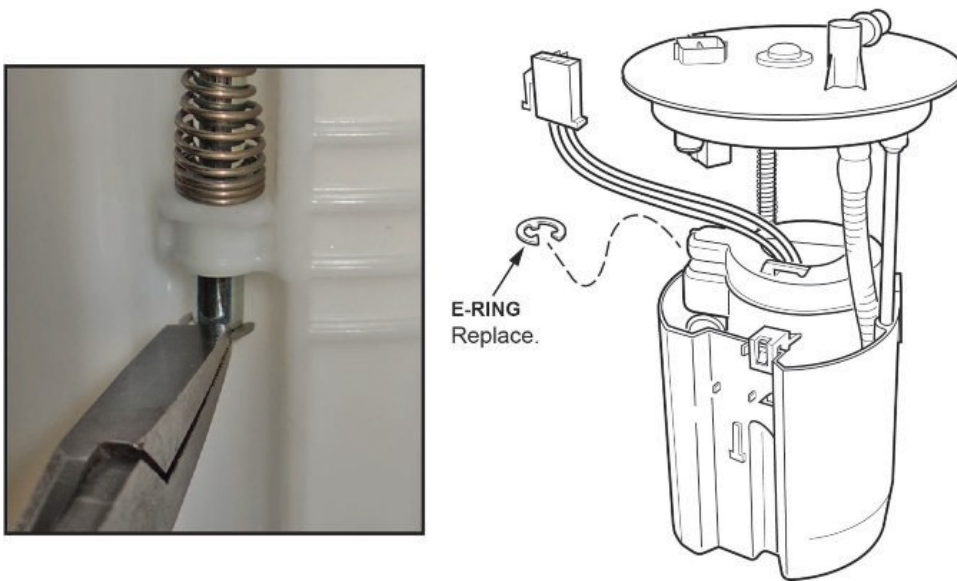

8.5. Remove the fuel filter assembly from the reservoir by releasing the three clips.

NOTE:

- Do not spread the clips too wide. Spreading them too wide may damage them.
- If the O-ring remains on the fuel filter, use a flat-tip screwdriver wrapped in protective tape to remove it. Take care not to damage the O-ring seat section.
- The spring may slide off the sliding shaft. Retain this spring. It will be used during assembly.

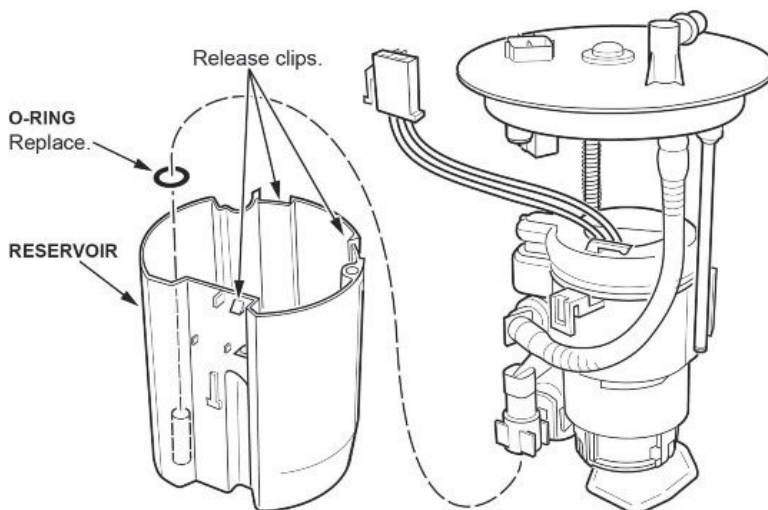

8.6. Remove the fuel pump assembly from the fuel filter.

- Release the three clips at the base of the fuel pump assembly.
- Pull the fuel pump assembly out of the fuel filter.
- If the O-ring remains on the fuel filter, use a flat-tip screwdriver wrapped in protective tape to remove it. Make sure not to damage the O-ring seat section.

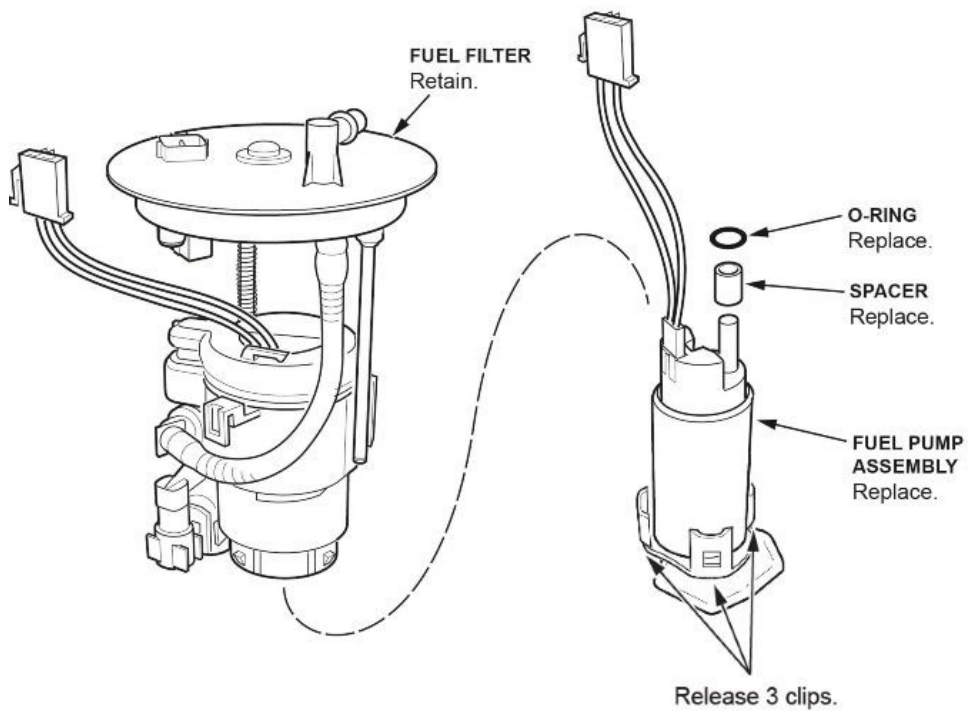

9. Assemble the fuel tank unit.

9.1. Install the new spacer on the new fuel pump motor.

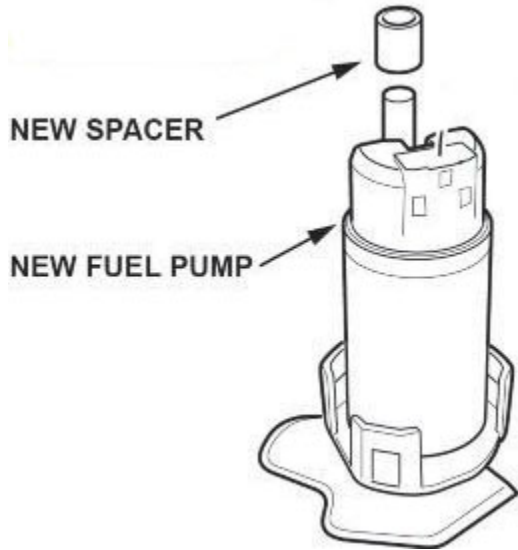

9.2. Install the new O-ring, then lubricate the outside edge of it, using only clean engine oil.

NOTE: Do not pinch the O-ring during installation.

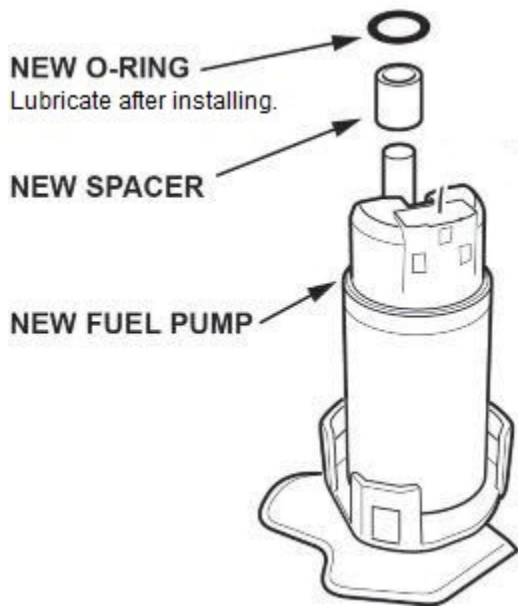

9.3. Install the new harness and make sure the connection is secure and the connectors are firmly locked into place.

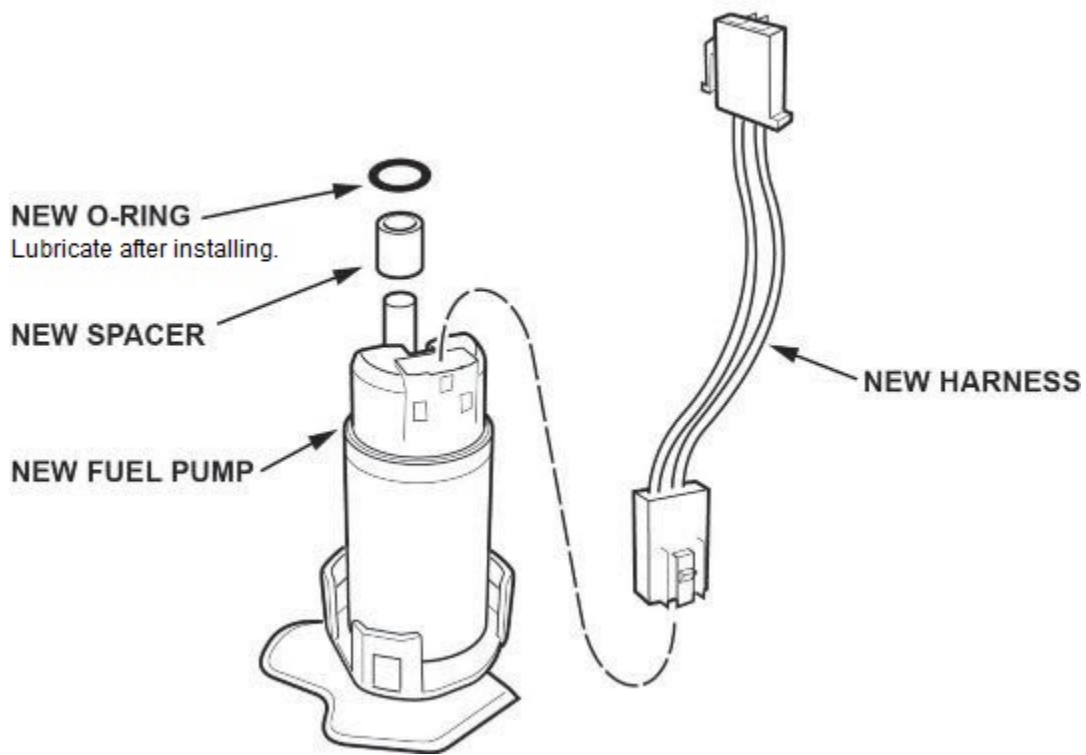

9.4. Place the fuel pump on a bench, then install the filter to the fuel pump.

NOTE: If the fuel the pump does not engage into the fuel filter in one step, confirm that the O-ring is still set before repeating fuel pump installation.

9.5. Install the fuel filter assembly to the reservoir.

- Insert the spring to the sliding shaft and make sure it is aligned when installing the fuel filter.

NOTE:

- Make sure the fuel tube is routed **exactly** as shown in the photo taken before disassembly.
- Make sure the three clips are fully engaged.

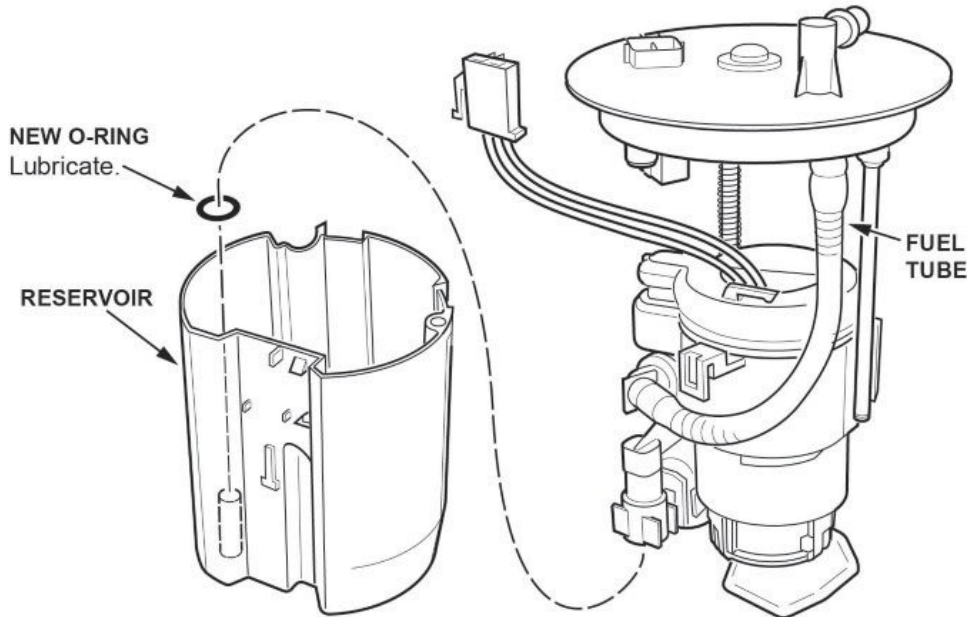

9.6. Install the new E-ring.

NOTE: After installation, make sure the E-ring can be rotated with your finger. If it cannot be rotated, the E-ring may not be fully seated or may be incorrectly installed.

9.7. Install the fuel level sensor to the reservoir. Make sure the lock is engaged.

NOTE: When installing the fuel level sensor, make sure the connection is secure and the connector is firmly locked into place. Be careful not to bend or twist it excessively.

9.8. Install the wiring harness to the clamps.

NOTE:

- Clip in the smaller harness wires followed by the larger wires.
- Make sure not to damage the wire harness.
- Make sure the wire harness is routed **exactly** as shown in the photo taken before disassembly.
- Do not spread the clamps too wide. Spreading them too wide may damage them.

HARNESS ROUTING:

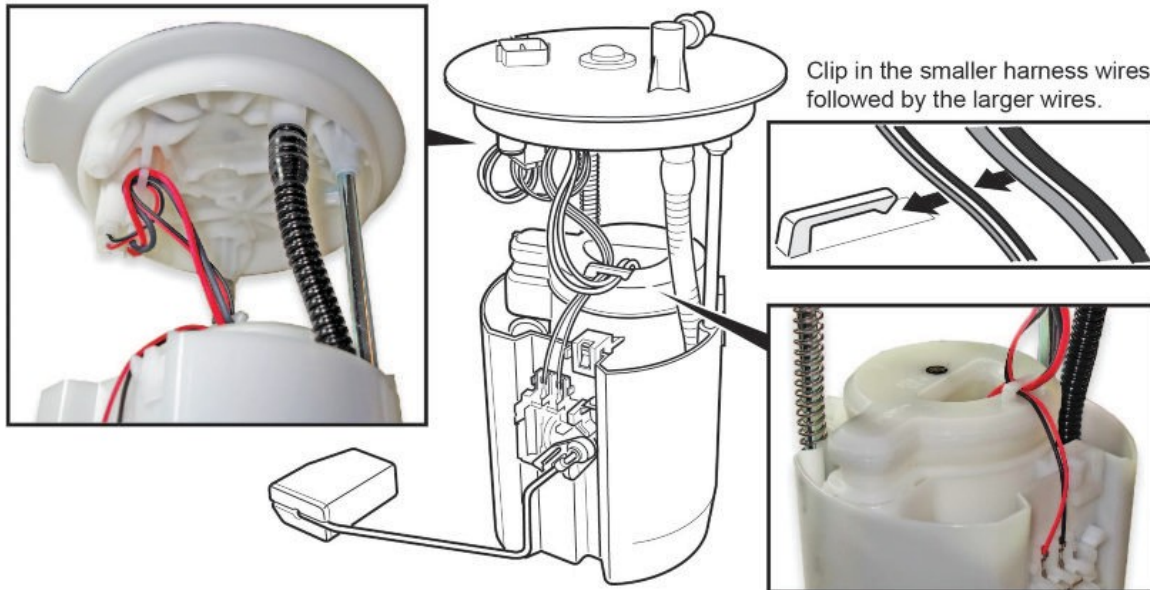

9.9. While compressing the fuel tank unit, make sure the movement is smooth and the fuel tube and wiring harness do not pinch or bind.

- Make sure the wire harness is not stretched.
- Make sure the fuel tube is not pinched.

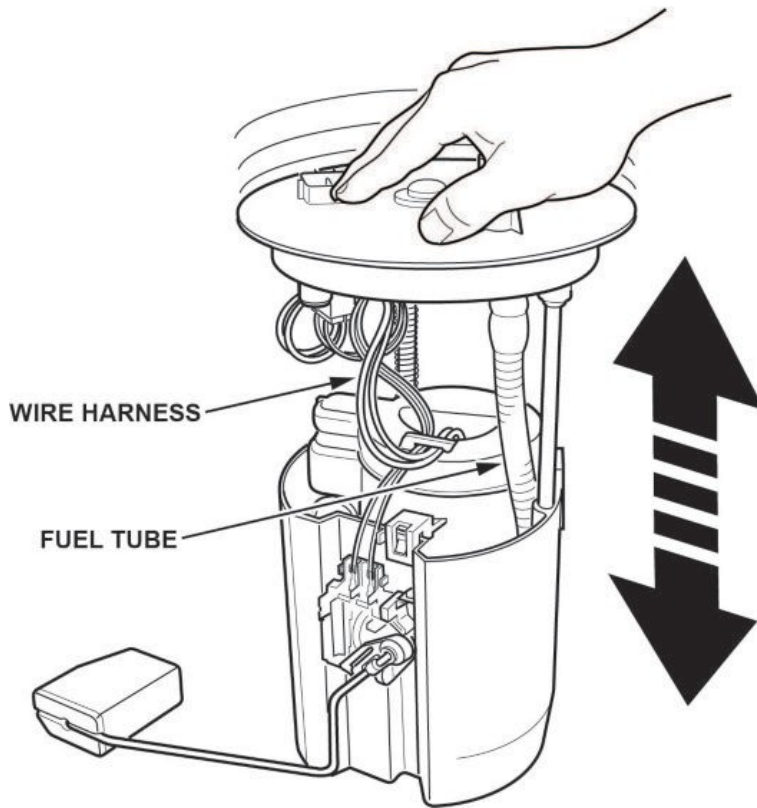

10. Install the fuel tank unit.

10.1. Partially insert the fuel tank unit into the fuel tank with a new O-ring.

NOTE:

- Be careful not to damage the new O-ring.
- Do not coat the O-ring with any oil.



10.2. Line up the tab of the fuel tank unit as shown, and temporarily insert the new fuel tank unit cam lock ring.

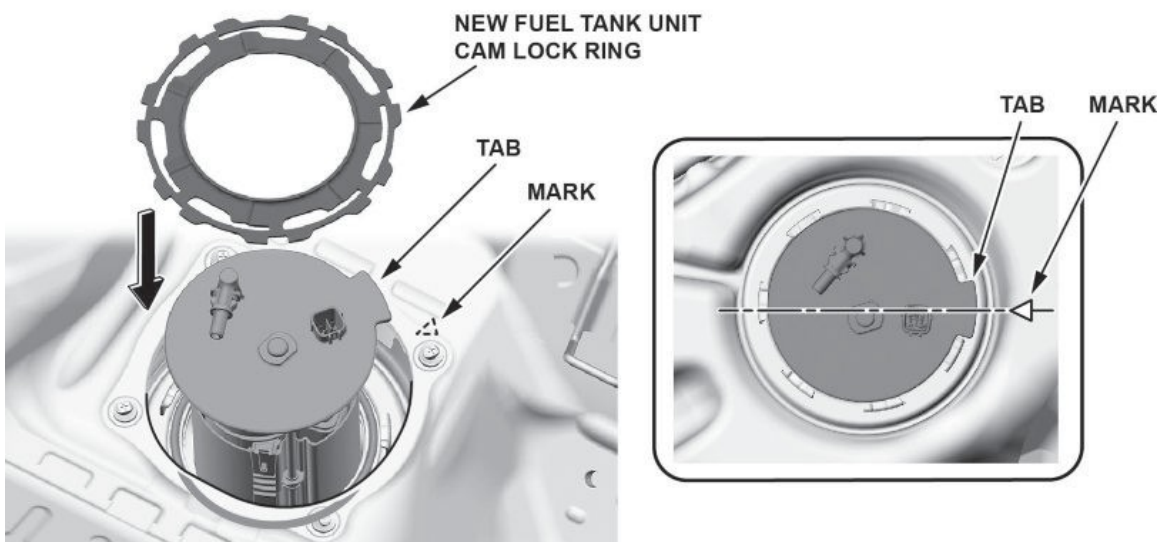

11. Lock the fuel tank unit cam lock ring.

NOTICE

If the cam lock ring is not properly installed, the fuel tank can be damaged and will require replacement.

11.1. Rotate the fuel tank unit cam lock ring, and slide the fuel tank unit cam lock tabs to the positioning edge as shown, by hand.

NOTE: Make sure the fuel tank unit cam lock ring is not floating.

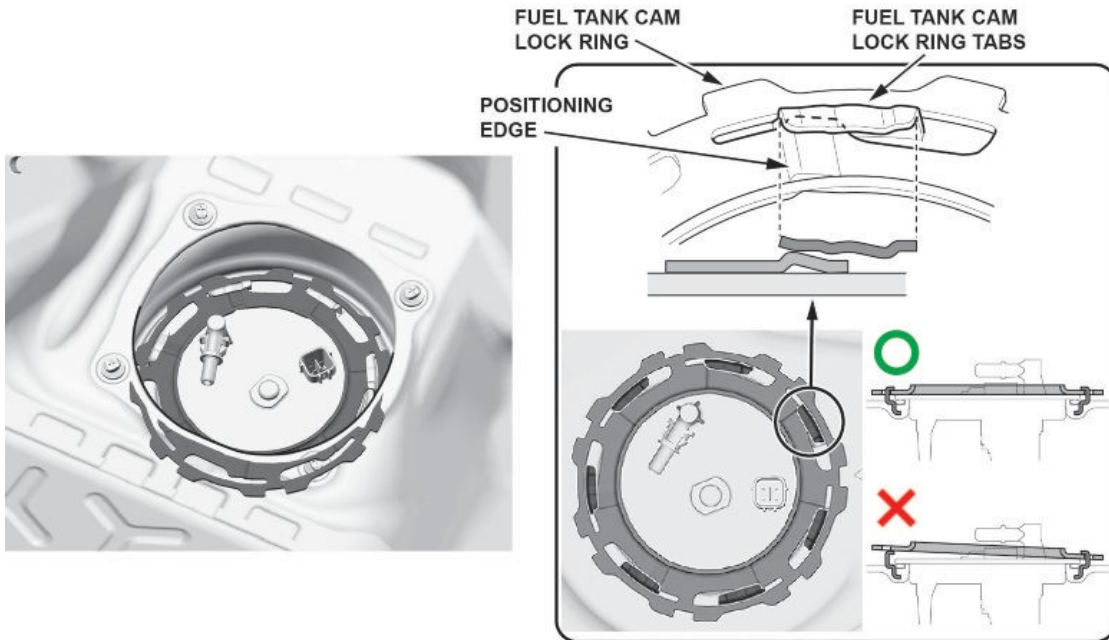

11.2. Turn the fuel tank unit cam lock ring clockwise using the fuel sender wrench.

NOTE:

- Keep the fuel sender wrench from floating.
- Securely set the positioning edge of the fuel tank at the fuel tank unit cam lock ring tabs on the fuel tank unit cam lock ring as shown.

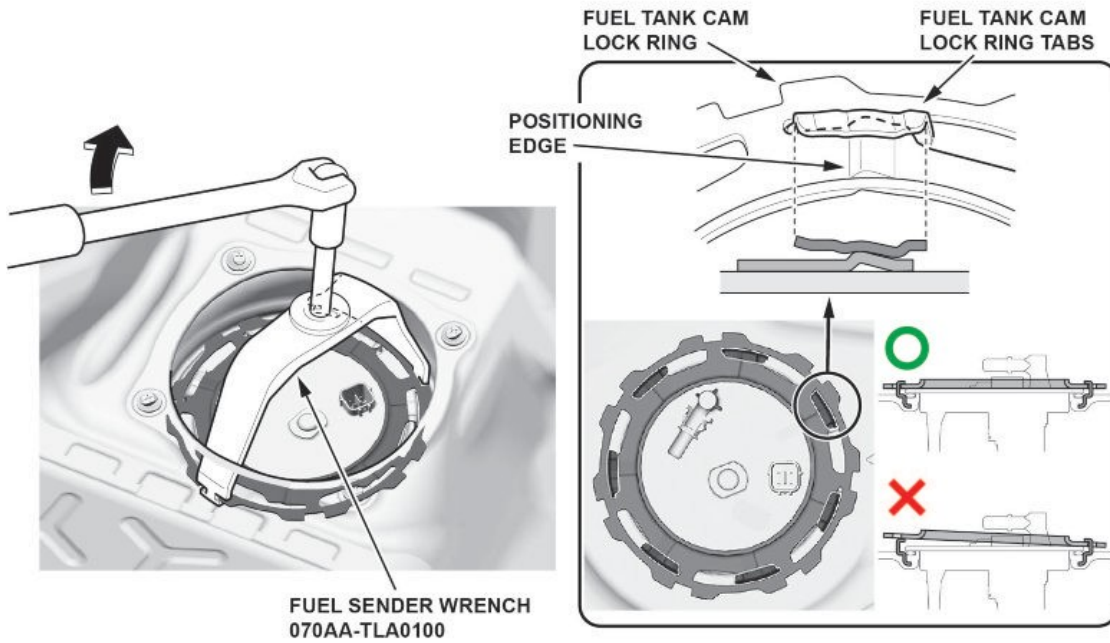

12. Install the new retainer to the quick-connect fitting.

13. Connect the fuel line quick-connect fitting.

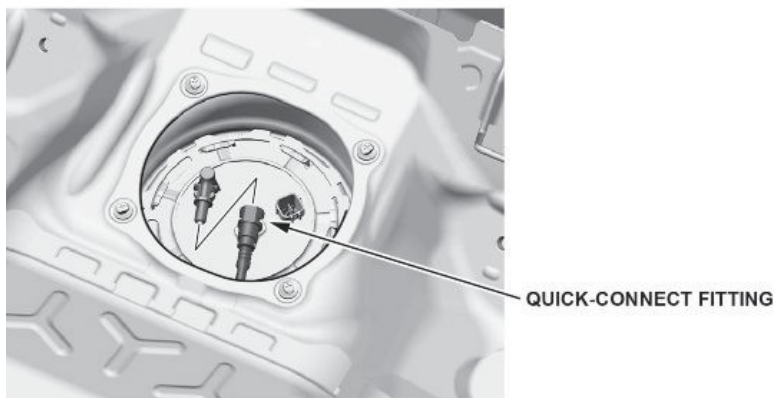

14. Connect the fuel tank unit connector.

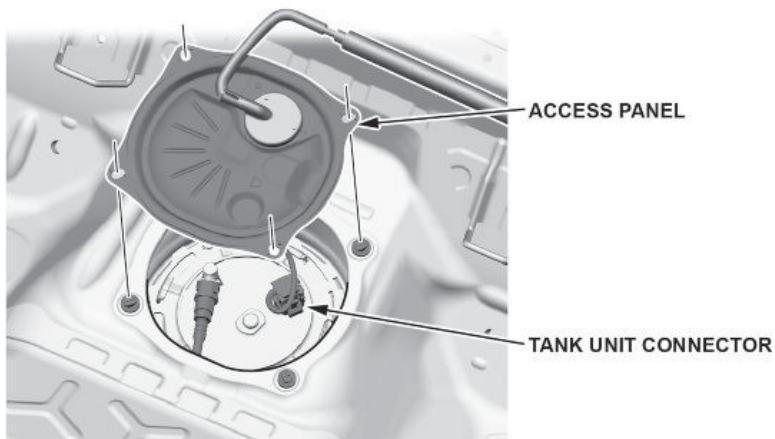

15. Check for fuel leaks.

15.1. Turn the ignition to ON, but do not start the engine. After the fuel pump runs for about **2 seconds**, the fuel line will be pressurized. Repeat this two or three times, then make sure there is no fuel leakage.

16. Install the fuel tank unit access panel.

17. Install the remaining parts in the reverse order of removal.

18. Clear all DTCs using an i-HDS.

19. Do the VSA Sensor Neutral Position Memorization procedure.

20. *California residents only.* Fill out a Vehicle Emissions Recall – Proof of Correction certificate, and use **F7I** as the recall number. Have the service advisor give the certificate to your customer, and advise him or her to keep it as proof that the recall was completed. Your customer will need to submit this certificate to the DMV only if the DMV requests it. If you need more certificates, use reorder number **Y0657**.

A form titled "Vehicle Emission Recall - Proof of Correction" with fields for License Number, Make, Year Model, Body Type, and Vehicle Identification Number. The Recall Number field is circled and contains the text "F7I". The form also includes a section for the Dealer's Name and Address, City, State and Zip, and a section for the Date and Dealership's Authorized Signature. A note at the bottom states: "Return this certificate to DMV only when required - otherwise retain for your records." The form number Y0657 and the code ACL 24832 (0212) are visible at the bottom.

END