

August 6, 2021

Version 4

## Safety Recall: 2019 RLX Fuel Pump Motor

Supersedes 20-028, dated June 19, 2020, to revise the information highlighted in **yellow**.

### AFFECTED VEHICLES

Year	Model	Trim Level	VIN Range
2019	RLX (except Sport Hybrid)	ALL	Check the iN VIN status for eligibility.

### REVISION SUMMARY

Under REPAIR PROCEDURE, steps 7, 9.1, 9.2, 9.3, 9.4, and 10.1 were revised.

### BACKGROUND

Due to swelling of the fuel pump motor impeller, the fuel pump may seize and stop working. If this occurs, the engine may not start, or the engine could stall while driving, increasing the risk of a crash.

### CLIENT NOTIFICATION

Owners of affected vehicles will be sent a notification of this campaign.

Do an iN VIN status inquiry to make sure the vehicle is shown as eligible.

Some vehicles affected by this campaign may be in your new or used vehicle inventory.

Failure to repair a vehicle subject to a recall or campaign may subject your dealership to claims or lawsuits from the client or anyone else harmed as a result of such failure. To see if a vehicle in inventory is affected by this safety recall, do a VIN status inquiry before selling it.

### CORRECTIVE ACTION

Replace the fuel pump motor.

**CLIENT INFORMATION:** The information in this bulletin is intended for use only by skilled technicians who have the proper tools, equipment, and training to correctly and safely maintain your vehicle. These procedures should not be attempted by "do-it-yourselfers," and you should not assume this bulletin applies to your vehicle, or that your vehicle has the condition described. To determine whether this information applies, contact an authorized Acura automobile dealer.

## PARTS INFORMATION

NOTE: Due to limited supply, this is a controlled part and will require a valid VIN when ordering.

Part Name	Part Number	Quantity
Fuel Pump Motor Kit	06170-TY2-306	1

**For dealers experiencing a strong fuel smell from storing a fuel pump motor replaced under this service bulletin**, the fuel pump motor may be disposed of immediately in accordance with local regulations. This only applies to the fuel pump motor replaced under this service bulletin. The published retention policy remains in effect for all other parts. If you have any questions about this exception or other parts retention issues, contact the WPI Administrative Office at **937-642-2737**.

## TOOL INFORMATION

Part Name	Tool Number	Quantity
Denso Fuel Module Separator Set	07AAF-T5RA100	1
Fuel Sender Wrench	07AAA-S0XA100	1

## WARRANTY CLAIM INFORMATION

Operation Number	Description	Flat Rate Time	Defect Code	Symptom Code	Template ID	Failed Part Number
3101HK	Replace the fuel pump motor.	1.1 hr	6FE00	R7C00	B20028A	17045-TY2-A00

## REPAIR PROCEDURE

### ⚠ WARNING

Fuel pump motor removal exposes fuel, which can ignite, causing a fire or explosion.

This can cause serious injury or death.

Always work in a well-ventilated area and keep sparks or open flames away.

1. Relieve the fuel pressure.
  - 1.1. Remove the emergency fuel funnel from the case, then insert it into the fuel filler neck to relieve the pressure in the fuel tank.

NOTE: The emergency fuel funnel is in the trunk tool box.

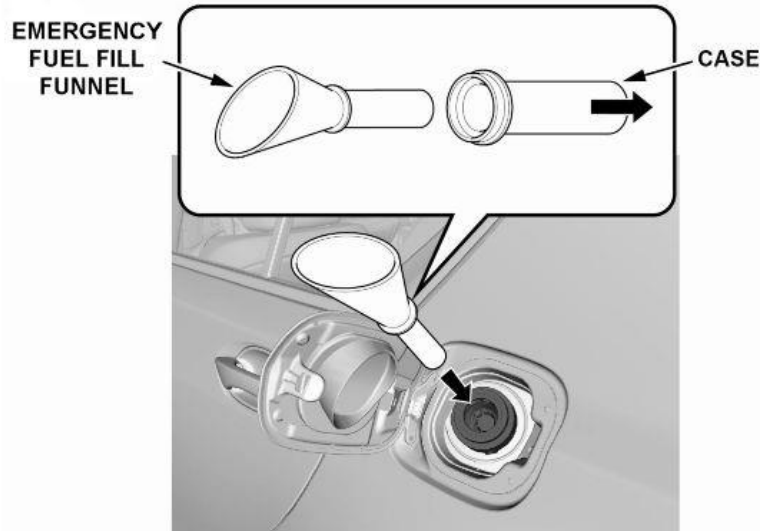

1.2. Remove PGM-FI main relay 2 from the driver's under-dash fuse/relay box.

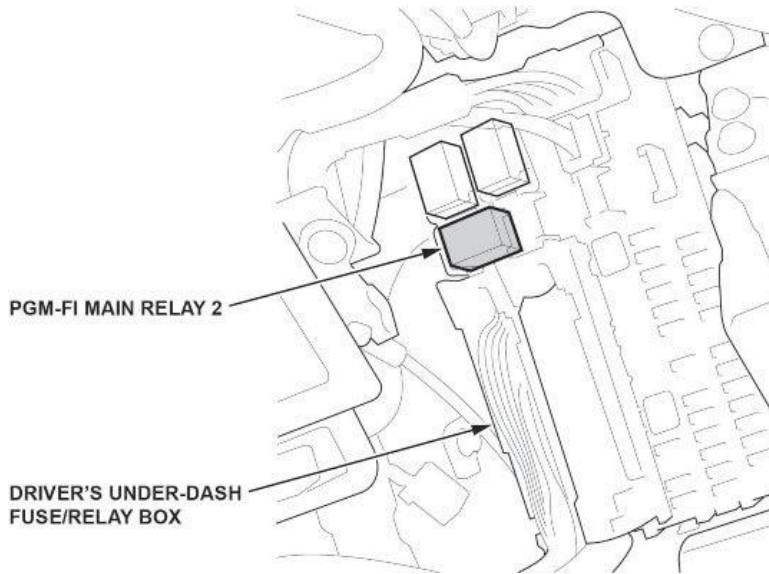

1.3. Start the engine, and let it idle until it stalls.

1.4. Turn the ignition to OFF.

1.5. Install PGM-FI main relay 2.

2. Disconnect both 12-volt battery terminals.

**NOTICE**

- Always disconnect the negative terminal first.
- To protect the terminal connector from damage, do not hold it when removing the terminal.
- Do not disconnect the 12-volt battery sensor from the cable.

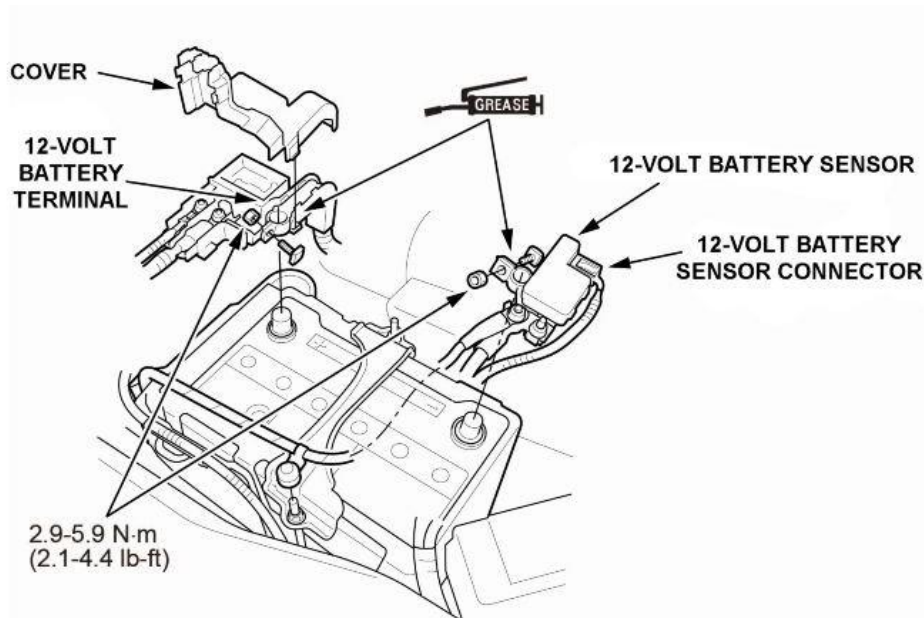

3. Remove the rear seat cushion.
  - 3.1. Remove the bolt between the rear seat-back and the rear seat cushion.

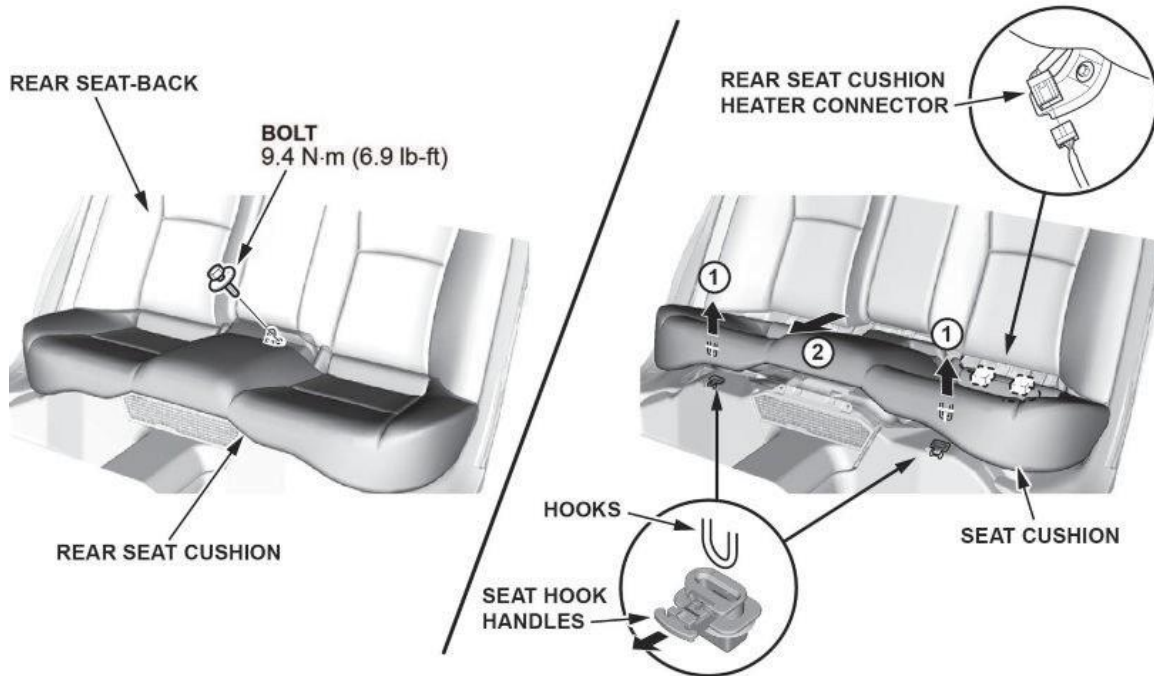

- 3.2. While pushing down on the seat cushion, pull the seat hook handles to release the hooks.
  - 3.3. *With rear seat cushion heater.* Disconnect the rear seat cushion heater connector.
  - 3.4. Remove the rear seat cushion.
4. Remove the fuel tank unit access panel, and disconnect the fuel tank unit connector.

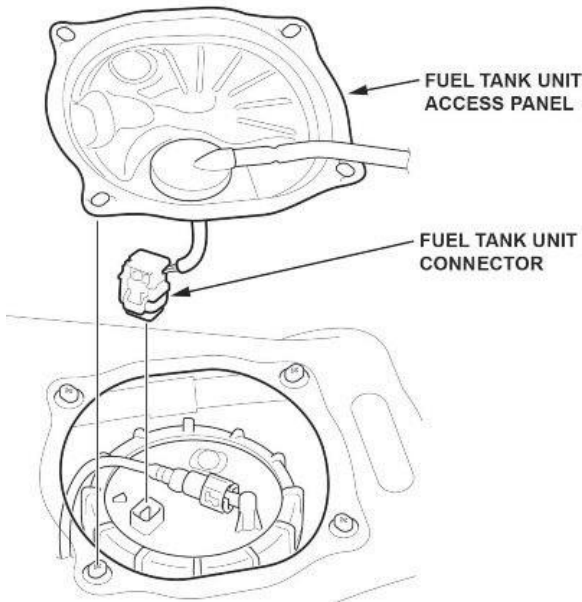

5. Place a rag or shop towel over the quick-connect fitting, and disconnect it.

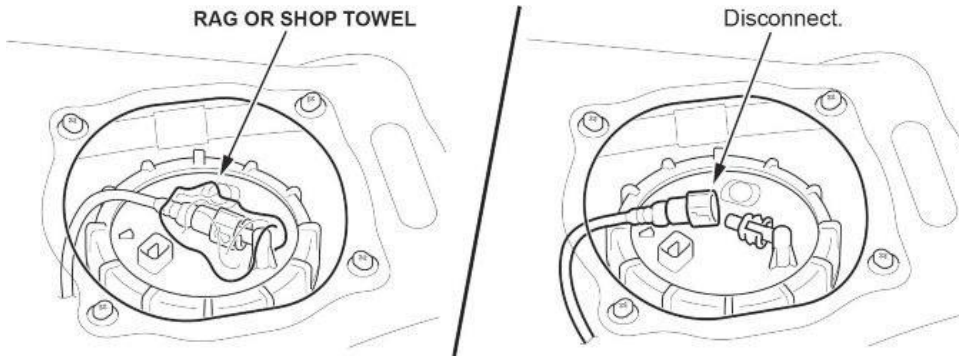

6. Unlock the fuel tank unit locknut using the fuel sender wrench (T/N 07AAA-S0XA100).

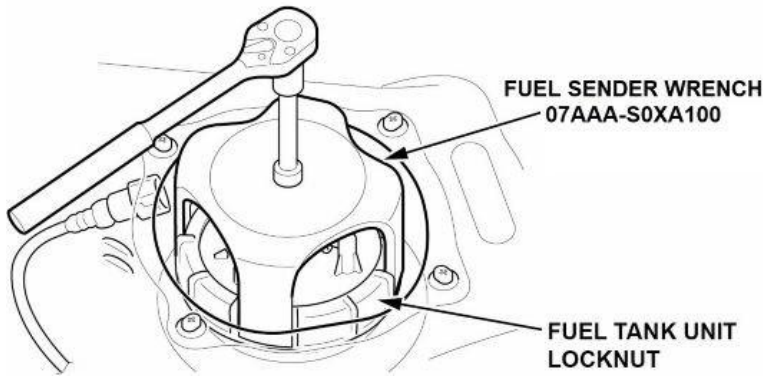

7. Remove the fuel tank unit locknut, and remove the fuel tank unit.

**NOTE:**

- After unlocking the fuel tank unit cam lock ring, clean the top of the fuel pump flange and adjacent areas to make sure it's free of dirt, dust, and debris.
- Make sure not to bend or twist the fuel level sensor arm excessively.

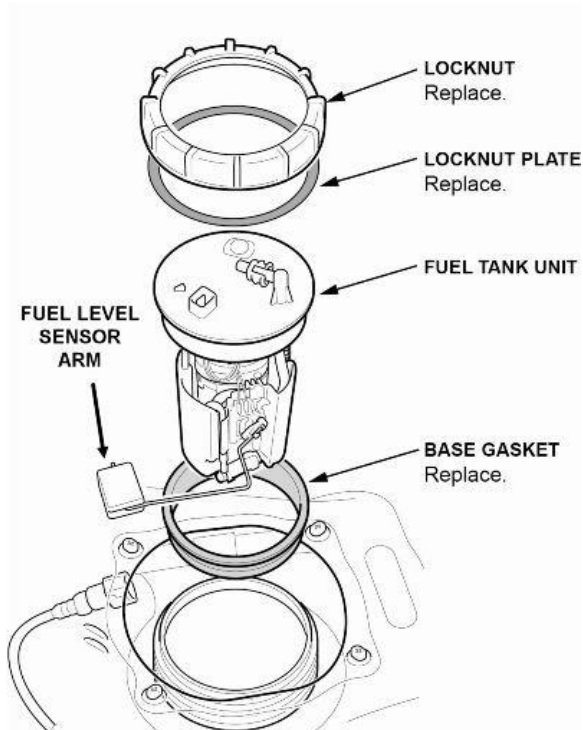

8. Disassemble the fuel tank unit.

8.1. Prepare the fuel tank unit and parts to be replaced.

NOTE: Take a photo of the fuel tube and wire harness, and note their routing for assembly. There are various types of routing.

8.2. Spread the wire harness clamps, and remove the wire harness. Make sure not to damage the wire harness.

**NOTICE**

Do not spread the clamps too wide. Spreading them too wide may damage them.

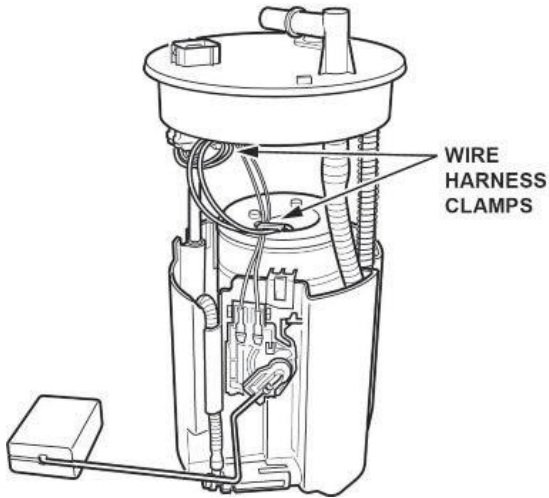

8.3. Remove the fuel level sensor.

- Disconnect the harnesses.

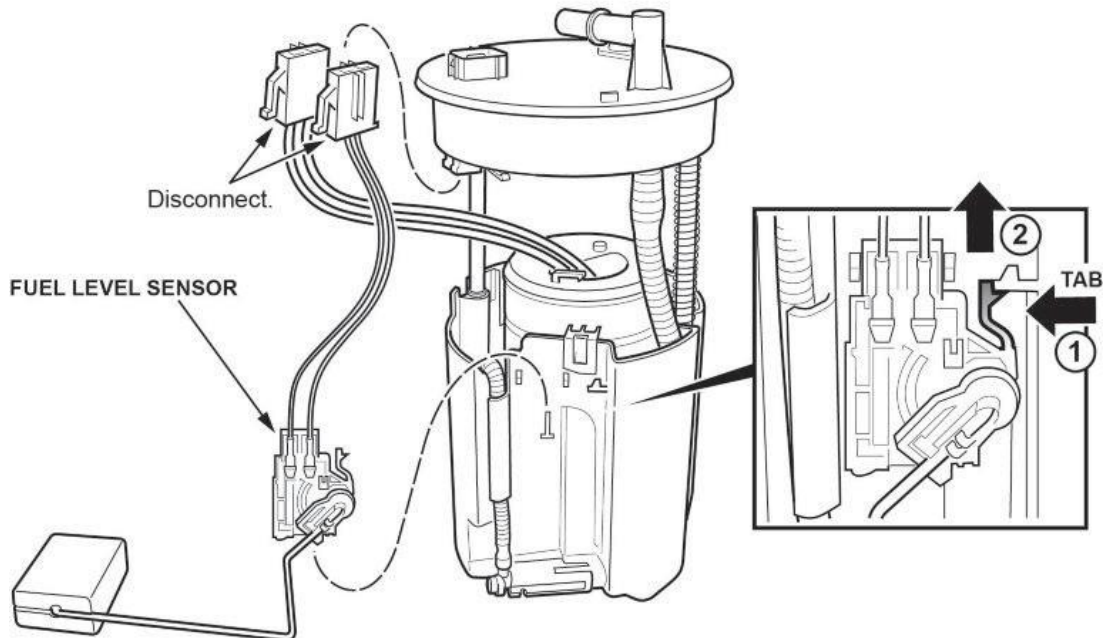

- Press the tab to release the lock (1). Then, push up on the fuel gauge sending unit (2).
- Remove the fuel level sensor from the fuel tank unit.

8.4. Remove the E-rings, and throw them away. Do not use them again.

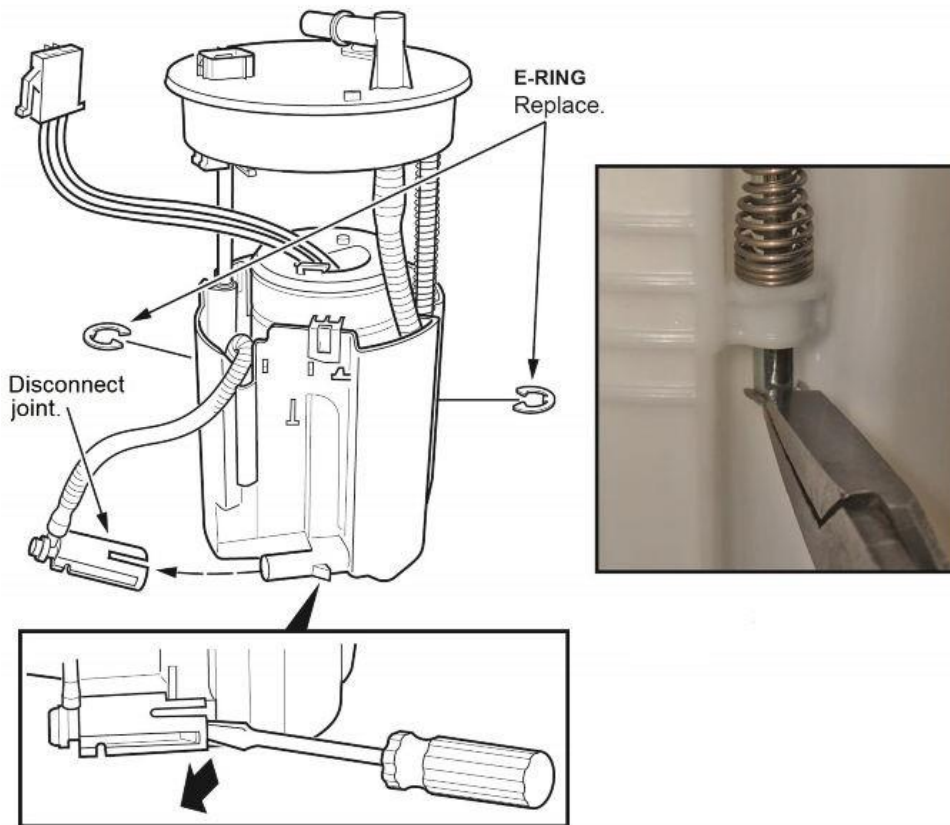

8.5. Disconnect the joint at the bottom of the reservoir.

8.6. Remove the fuel filter assembly from the reservoir by releasing the three clips.

**NOTE:**

- Use the clip release tools on two of the clips.
- The spring may slide off the sliding shaft. Retain this spring. It will be used during assembly.

**NOTICE**

Do not spread the clips too wide. Spreading them too wide may damage them.

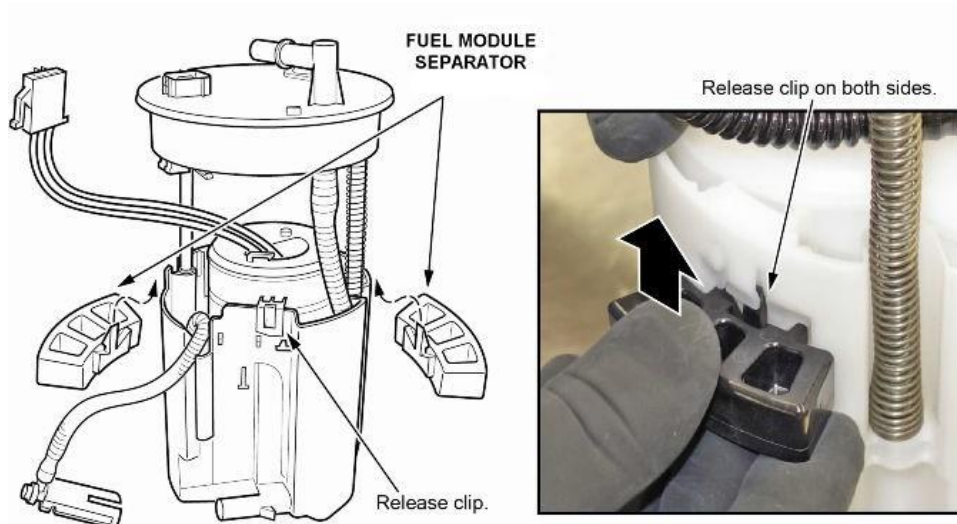



- 8.7. Remove the fuel pump assembly from the fuel filter.
- Release the three clips at the base of the fuel pump assembly.
  - Pull the fuel pump assembly out of the fuel filter.

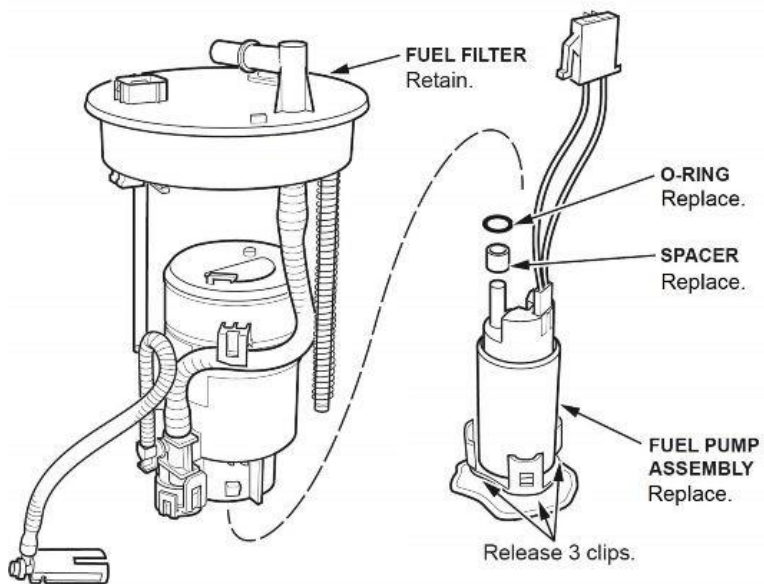

9. Assemble the fuel tank unit.

- 9.1. **Install the new spacer on the new fuel pump motor.**

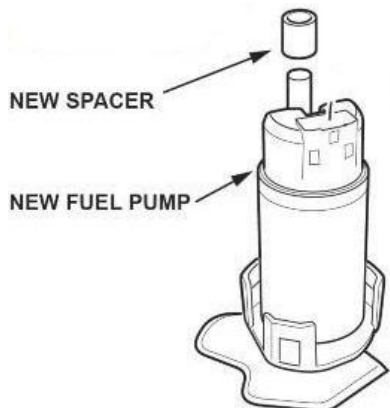

9.2. Install the new O-ring, then lubricate the outside edge of it, using only clean engine oil.

**NOTE:** Do not pinch the O-ring during installation.

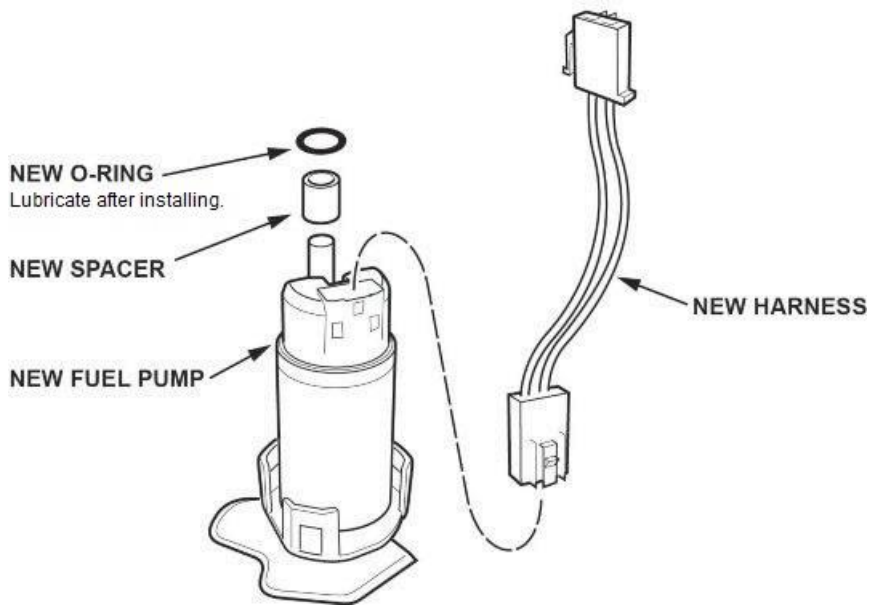

9.3. Install the new harness and make sure the connection is secure and the connectors are firmly locked into place.

9.4. Place the fuel pump on a bench, then install the filter to the fuel pump.

**NOTE:** If the fuel pump does not engage into the fuel filter and re-insertion is necessary, confirm that the O-ring is seated on the fuel pump before repeating installation.

9.5. Install the fuel filter assembly to the reservoir.

NOTE:

- Insert the spring into the sliding shaft, and make sure it is lined up when installing the fuel filter.
- Make sure the fuel tube is routed **exactly** as shown in the photo taken before disassembly.
- Make sure the three clips are fully engaged.

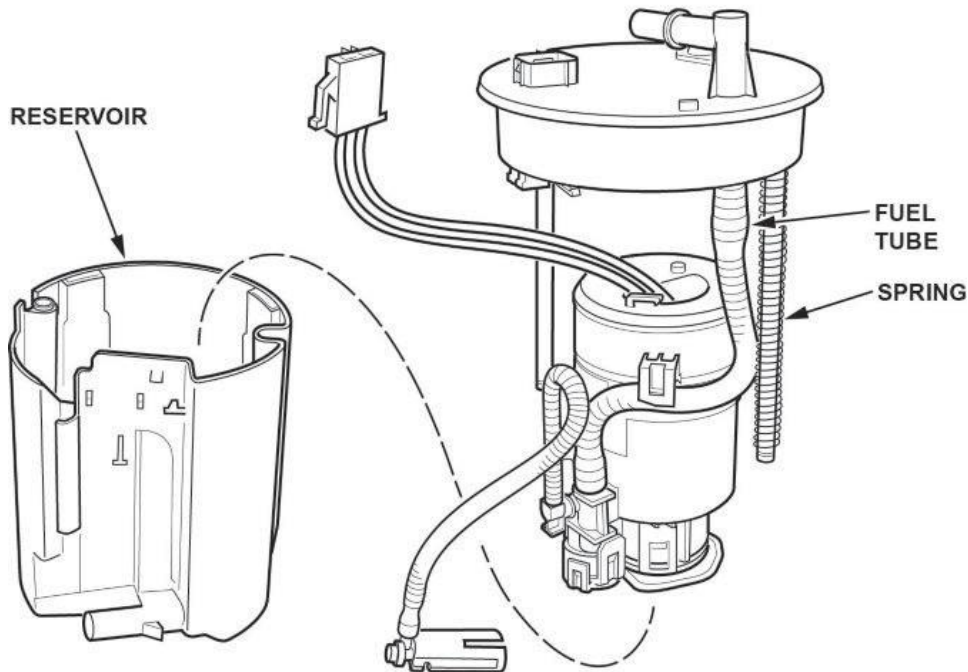

9.6. Install the new E-rings.

NOTE: After installation, make sure the E-rings can be rotated with your finger. If they cannot be rotated, the E-rings may not be fully seated or may be incorrectly installed.

9.7. Install the fuel level sensor to the reservoir. Make sure the lock is engaged.

NOTE: When installing the fuel level sensor, make sure the connection is secure and the connector is firmly locked into place. Be careful not to bend or twist it excessively.

9.8. Install the wiring harness to the clamps.

NOTE:

- Clip in the smaller harness wires followed by the larger wires.
- Make sure not to damage the wire harness.
- Make sure the wire harness is routed **exactly** as shown in the photo taken before disassembly.
- Do not spread the clamps too wide. Spreading them too wide may damage them.

**HARNESS ROUTING:**



9.9. While compressing the fuel tank unit, make sure the movement is smooth and the fuel tube and wiring harness do not pinch or bind.

- Make sure the wire harness is not stretched.
- Make sure the fuel tube is not pinched.

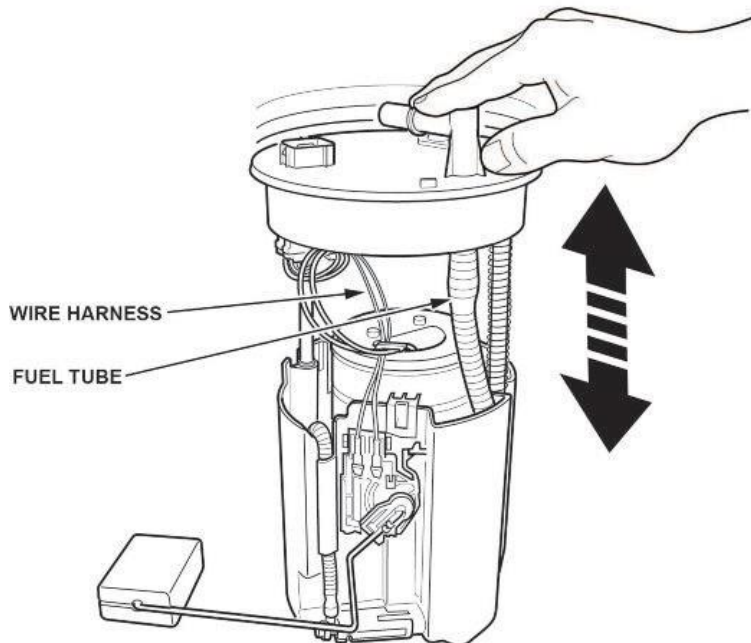

10. Install the fuel tank unit.

10.1. Partially insert the fuel tank unit into the fuel tank with a new base gasket.

NOTE:

- Before installing the new O-ring, clean the fuel tank around the fuel pump opening where the O-ring will seat. The tank opening must be free of dirt, dust, and debris.
- Be careful not to damage the new base gasket.
- Be careful not to bend the fuel gauge sending unit arm.
- Do not coat the base gasket with any oil.

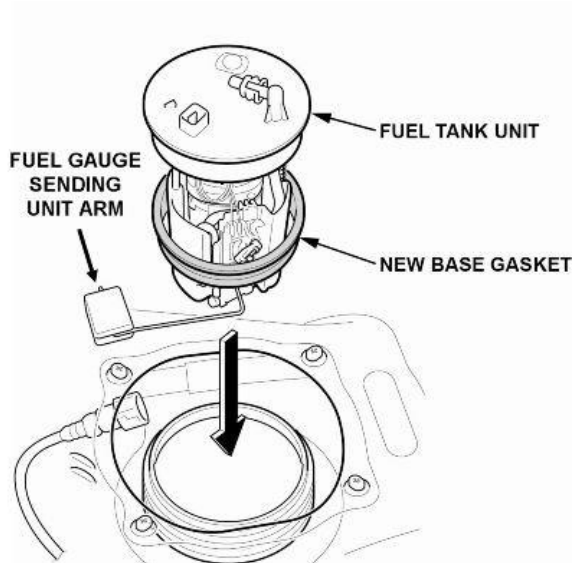

10.2. Line up the marks on the fuel tank and fuel tank unit, then insert the fuel tank unit into the fuel tank.

NOTE: To avoid a fuel leak, visually or by hand, make sure the base gasket is not pinched.

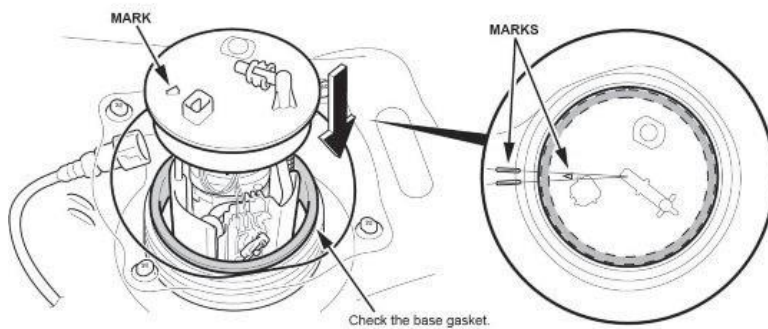

11. Tighten the fuel tank unit locknut.

**NOTICE**

If the locknut is not properly installed, the fuel tank can be damaged and will require replacement.

11.1. Hold the fuel tank unit vertically, and tighten a new fuel tank unit locknut with a new locknut plate by hand.

NOTE: Before tightening, line up the mark on the locknut to the start of the thread.

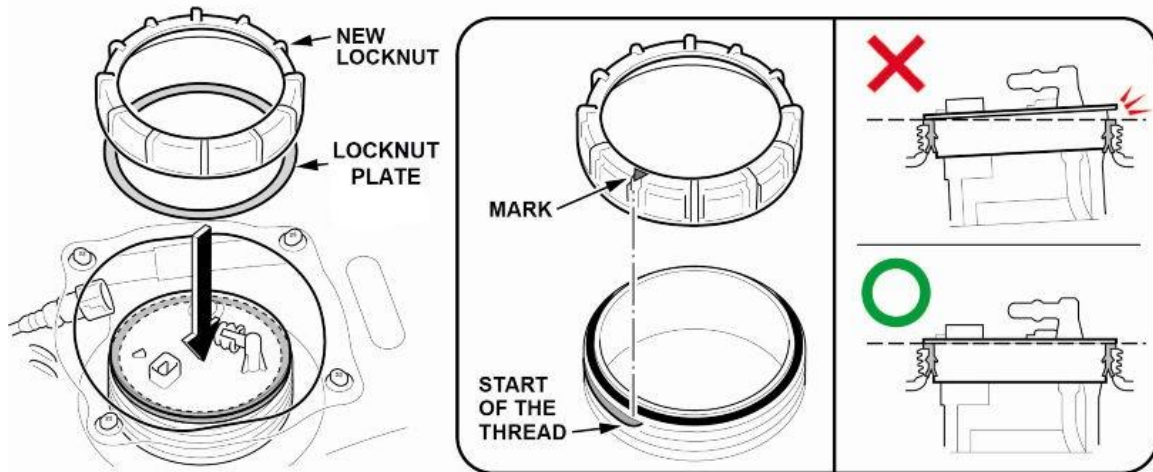

11.2. Tighten the fuel tank unit locknut to the specified torque using the fuel sender wrench.

NOTE:

- After tightening, make sure the marks are still lined up.
- Visually or by hand, make sure the base gasket is not pinched.

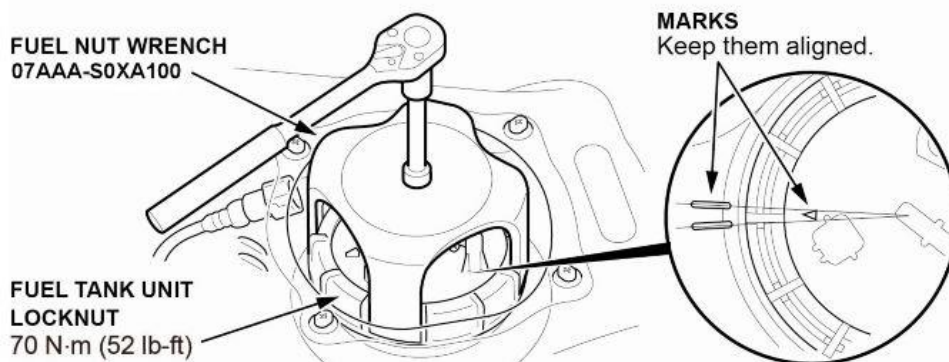

12. Install the new retainer to the quick-connect fitting.

13. Connect the fuel line quick-connect fitting and fuel tank unit connector.

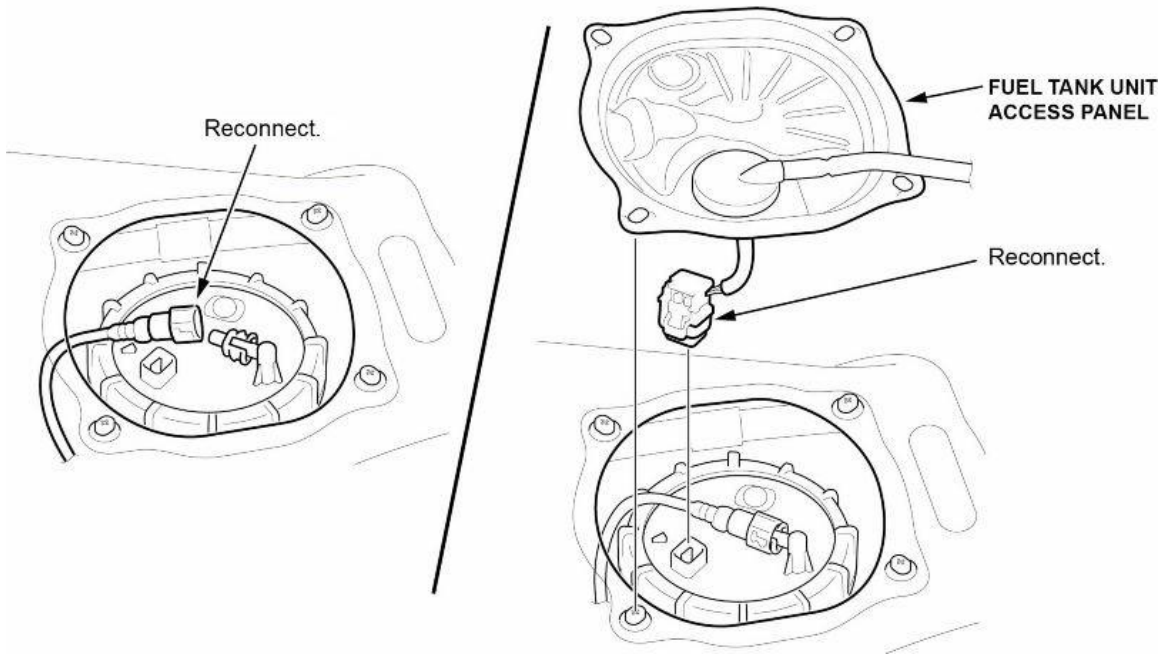

14. Connect the 12-volt battery terminals.

15. Check for fuel leaks.

15.1. Turn the ignition to ON, but do not turn the engine on. After the fuel pump runs for about **2 seconds**, the fuel line will be pressurized. Repeat this two or three times, then make sure there is no fuel leakage.

16. Install the fuel tank unit access panel.

17. Install the remaining parts in the reverse order of removal.

18. Clear all DTCs using an i-HDS.

19. *California residents only:* Fill out a Vehicle Emissions Recall – Proof of Correction certificate, and use **R7C** as the recall number. Have the service consultant give the certificate to your client, and advise him or her to keep it as proof that the recall was completed. Your client will need to submit this certificate to the DMV only if the DMV requests it. If you need more certificates, use reorder number **Y0657**.

Vehicle Emission Recall - Proof of Correction				
License Number	Make	Year Model	Body Type	Vehicle Identification Number
Manufacturer			Recall Number <b>R7C</b>	
The above described vehicle has been repaired, modified and/or equipped with new emission control devices to meet applicable California Emission Control Laws.				
Dealer's Name		Address, City, State and Zip		
Date	Dealership's Authorized Signature			
	X			
Return this certificate to DMV <u>only</u> when required - otherwise retain for your records.				

Y0657 ACL 24832 (0212)

END