

REPLACES: Please discard bulletin MC20-02 dated June 5, 2020.

TITLE: ENGINE BACKFIRE

RECALL

THIS BULLETIN IS OF THE HIGHEST PRIORITY AND MUST BE ACTED UPON IMMEDIATELY TO ENSURE CUSTOMER SAFETY.

Eligibility

Eligible Units

Year	Model	Model Codes
2019	NINJA® ZX™ -10R ABS	ZX1002EKF
	NINJA ZX-10R ABS KRT Edition	ZX1002EKFA
	NINJA ZX-10R ABS KRT Edition	ZX1002EKFAL
	NINJA ZX-10R ABS	ZX1002EKFL
	NINJA ZX-10R	ZX1002FKF
	NINJA ZX-10R KRT Edition	ZX1002FKFA
	NINJA ZX-10R KRT Edition	ZX1002FKFAL
	NINJA ZX-10R	ZX1002FKFL
	NINJA ZX-10RR	ZX1002GKFL
2020	NINJA ZX-10R ABS	ZX1002ELF
	NINJA ZX-10R ABS KRT Edition	ZX1002ELFAL
	NINJA ZX-10R ABS	ZX1002ELFL
	NINJA ZX-10R KRT Edition	ZX1002FLFA
	NINJA ZX-10R KRT Edition	ZX1002FLFAL

Verify eligibility using VIP in K-Dealer before starting the repair.

Please check VIP (Vehicle Information Portal) in K-Dealer for other possible repair campaigns for eligible units.

Subject

On affected units, the engine could backfire while shifting under high engine loads when KQS (Kawasaki Quick Shifter) is activated, potentially resulting in damage to the air suction valve(s). Continued use could result in additional damage to surrounding parts caused by blow back of high temperature exhaust gas and creating the potential for a fire.

Kawasaki Action

Initiate Campaign:

Kawasaki has initiated a Recall campaign to repair all eligible units. The repair consists of reprogramming the ECU and replacing the air suction valve(s). A physical inspection of the area around the air suction valve assembly must also be carried out and repairs completed if required.

Notify Registered Owners:

Kawasaki is sending a Recall letter to all registered owners of eligible units. A copy of the letter is printed on page 13 of this bulletin.

Dealer Action

Repair Eligible Units:

Repair all eligible units including sold units in the field and unsold units in your dealership inventory prior to delivery to the retail purchaser. It is the obligation of authorized Kawasaki retail Dealers to repair eligible units in Dealer's possession prior to retail sale. Failure to comply with this obligation to repair all units eligible for Recall or FDM campaigns by the Dealer constitutes a breach of the Dealer Sales and Service Agreement. Refer to Service Policies bulletin SP 08-01. Refer to the Repair Procedure section of this bulletin for details.

IMPORTANT NOTE:

- o *It's the law! Under the U.S. National Highway Traffic Safety Administration (NHTSA), Federal Law 49 U.S.C. Section 30120(i) requires dealers to perform Recall repairs before delivering any vehicle affected by the Recall to a purchaser.*

Document Completed Repairs:

Federal law requires manufacturers to maintain accurate follow-up records on repairs performed on eligible units. Dealers MUST submit a Warranty Claim for each repair. Refer to the Warranty Information section of this bulletin for details.

NOTE:

- o *If you fail to submit a Warranty Claim for a new unit that is subsequently sold and registered, the new owner will receive the Recall letter requesting the return of the vehicle to you for repair.*

Submit Product Registration:

Submit the product registration to Kawasaki via K-Dealer immediately after retail sale of any eligible unit. Be sure to supply the correct customer name and mailing address. Kawasaki uses the product registration information for customer notification. Also, if you know that the customer has moved, please submit a Customer Update via K-Dealer.

Parts Information

Repair Kit Part Number:

Install repair parts only on vehicles that have been ridden. Unsold units that have not been ridden do not need repair parts

Order parts to complete the Recall through K-Dealer as outlined in Service Bulletin SP15-03.

Kit, Reed Valve, MC20-02 P/N 99999-0766		
Ref	Contents	Qty
1	Bolt	4
2	Valve	2



REPAIRS REQUIRED BASED ON RIDING HISTORY OF VEHICLE

- ★ If the unit has never been ridden, perform the ECU reprogramming only.
- ★ If the unit has been ridden, perform the ECU reprogramming, valve replacement and inspection.

Special Tool Requirements

This repair procedure requires the following special tools

- KVCS Kit
- Computer or laptop with KVCS installed
- Internet connection

ECU Reprogramming

IMPORTANT NOTES:

- o *The vehicle's battery voltage must be greater than 10.5 Volts to perform this procedure. Do not attempt to reprogram the ECU if the battery voltage is below 10.5 Volts. Charge the battery as required.*
- o *This procedure requires an internet connection and a computer with KVCS installed.*

- Connect cable **57001-1843** to the K-VCI device.



- Confirm the **power switch** on the K-VCI device to the **OFF** position.



- Connect K-VCI device to vehicle's white, **six pin coupler**, using cable **57001-1843**.



- Slide the **power switch** on the K-VCI device to the **ON** position.



ECU Reprogramming (cont'd)

- Once the vehicle, K-VCI and computer are connected turn on the ignition.
- Wait 10 seconds.



- Launch the KVCS software and click the ECU Reprogramming icon on the main menu screen.



- Click the "Next" button.

Vehicle ECU Data

ECU P/No : 21175-1558
CalID : 49245-1567
VIN : ML5EX650MMDA00090

ECU P/No : 21175-1558 Compatible Model List

Model	Model Year	Specification
ER650K	20-	EU
EX650M	20-	EU

Search History Next

- Verify the reprogramming data with the data in the applicable repair campaign then click the "DL" button.

Vehicle ECU Data

ECU P/No. : 21175-1558
CalID : 49245-1567

Model Year :
Model name :

1 Items of applicable reprogramming data found.

Reprogramming Data

ECU P/No.	CalID	Comment	Registration Date
21175-1554	49245-1556	Full Power	2021/03/02

Notes DL

Eligible ECU P/No. 21175-1554 , 21175-1558

- Enter the last 5 digits of the VIN.
- The mileage will be entered automatically if the ECU is capable of doing so.
- Click on the "Continue" button.

NOTE:

- If the VIN entered does not match the VIN registered in the ECU, the entire VIN must be manually entered to ensure the ECU reprogramming history is accurate. If they still do not match, enter the entire VIN again.

A VIN (Frame Number)

ECU may have been replaced. Be sure to enter the actual VIN stamped on the vehicle frame. Reprogramming can be done even if the VINS do not match.

VIN (Last 5 digits) ML5EX650MMDA

Mileage 10893 km

Continue

ECU Reprogramming (cont'd)

- Enter activation code **DAJ883A** then click on the “Certification” button.

ECU P/No. : 21175-1554
CalID : 49245-1556
Applicable ECU Part Number : 21175-1554,21175-1558
Comment : Full Power
Notes :
Registration Date : 2021/03/02

Activation Code : [XXXXXXXX] x

Certification

- Click on the “Download” button.

Registration Date : 2021/03/02

Activation Code : XXXXXXXX ✓

Download X Cancel

- Wait for the download to complete.

ECU Reprogramming

ECU P/No. : 21175-1118
CalID : 49245-0943
Eligible VIN : J1234567890123456
Download Date : 2021-02-05 10:28:23
Activation Code : N/A

Progress bar: [██████████] [██████████]

Continue

- Click on the “Next” button once the download is complete to start reprogramming the ECU.

Download completed. Click "Next" to start ECU Reprogramming.

Old			New	
ECU PIN	21175-1558	▶▶▶	ECU PIN	21175-1554
Cal ID	49245-1567		Cal ID	49245-1556

ECU icons

Cancel **Next**

ECU Reprogramming (cont'd)

- Wait for the reprogramming to finish.

CAUTION:

- o Do not disconnect any of the connections during reprogramming.
- o Do not turn off the K-VCI device during reprogramming.
- o Do not shut down KVCS during the reprogramming.

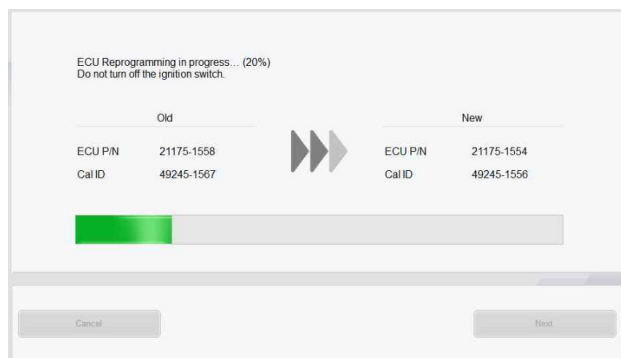

- Once the reprogramming is complete, enter **MC20-02** in the comment field.



- Click on the “Upload” button.

- Click on the “Report” button [R] to generate a reprogramming report if desired.
- Click on the “Home” button [H] to complete the reprogramming process.
- Turn the ignition key off.
- Close KVCS.
- Remove cables and K-VCI device.

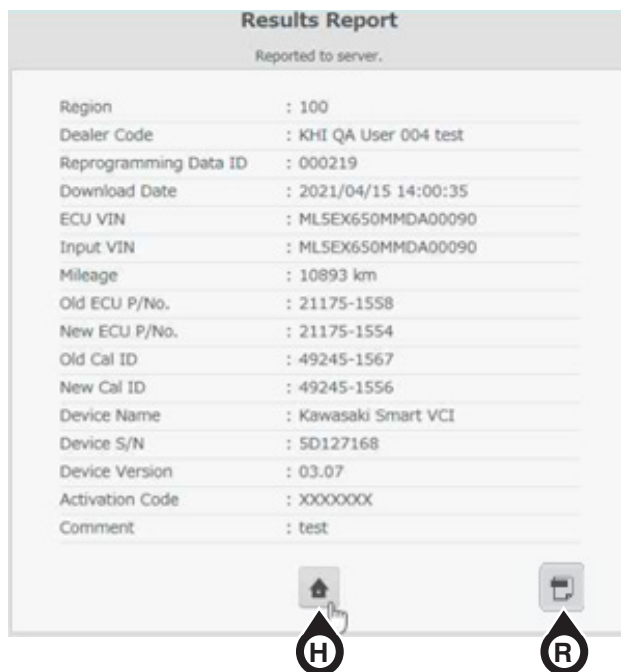

ECU REPROGRAMMING IS NOW COMPLETE

- Proceed to the **Warranty Section** on page 12 if the vehicle has **never been ridden**.
- Proceed to the **Remove & Replace Reed Valve** section on page 7 if the vehicle has been **ridden**.

Remove & Replace Reed Valves

REMOVE & REPLACE REED VALVES ONLY ON VEHICLES THAT HAVE BEEN RIDDEN.

- Remove the seat, tail cover, tank cover and fuel tank as outlined in service manual 99832-0011-01.

Remove Air Cleaner Housing

- Disconnect:
 - Secondary Fuel Hose
 - Intake Air Temp Sensor Connector [A]
 - IMU Connector [B]
 - Secondary Fuel Injector Connectors [C]
- Remove :
 - Turn signal relay [D],
 - Radiator fan relay [E]
 - ESD (Electronic Steering Damper) ECU [F]
- Free the clamps [G] from the air cleaner housing.
- Remove Connector Bracket [A]
- Slide the clamps.
- Disconnect:
 - Air Cleaner Drain Hose [B]
 - Breather Hose [C]
- Loosen air cleaner housing clamp bolts [D].

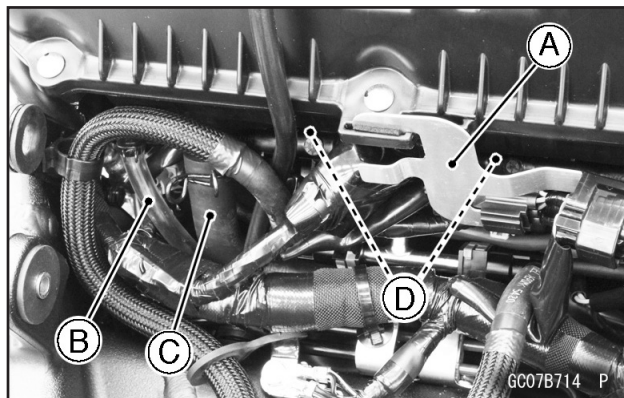
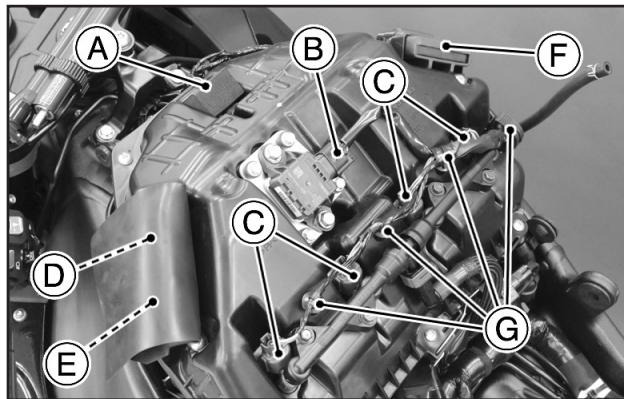

- Remove bolts [A].
- Free bracket [B].
- Remove bolt [C] and washer.

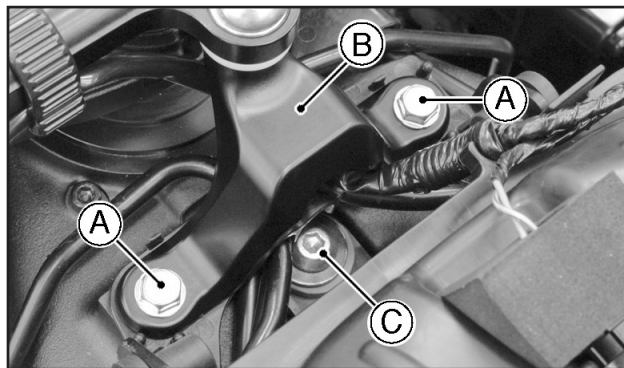

- Disconnect the air switching valve hose [A].
- Remove the air cleaner housing.

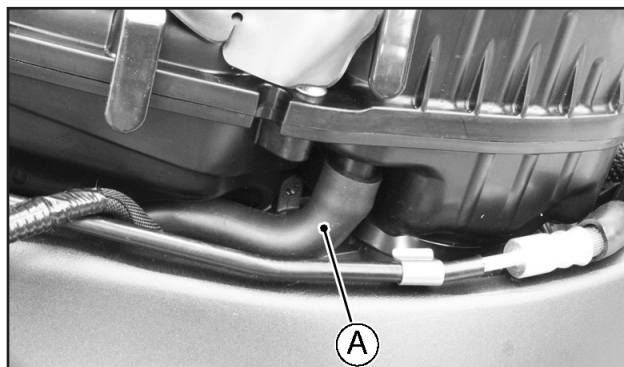

Remove & Replace Reed Valves (cont'd)

Remove Air Switching Valve

NOTICE

Never drop the air switching valve especially on a hard surface. Such a shock to the air switching valve can damage it.

- Disconnect connector [A].
- Disconnect hoses [B] from the air suction valve covers.
- Remove the air switching valve [C].

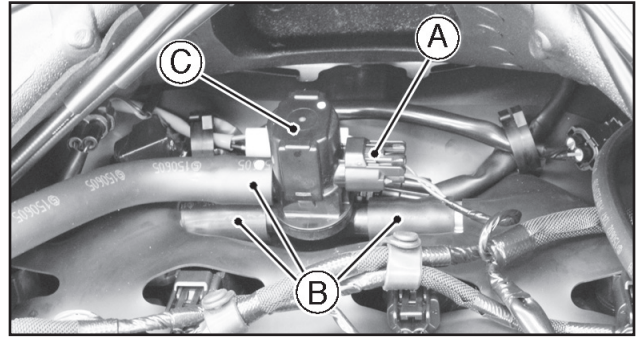

Remove Air Suction Valve

- Open clamps [A].
 - Roll up the front side of the heat insulation rubber plate [B].
-
- Remove and discard air suction valve cover bolts [A].
 - Remove and retain air suction valve cover [B].
 - Repeat for valve on the other side of the engine.
-
- Remove and discard air suction valves from both sides of the engine.
 - Install new air suction valves [A] on both sides of the engine with the reed stopper facing downwards and the white mark [B] toward the rear.
-
- Install the air suction valve covers [A] on the air suction valve [B].
 - Remove the locking agent from the air suction valve cover bolt holes with a thread chaser or a tap
 - Install new air suction valve cover bolts [C], and tighten to 89 in·lb (1.0 kgf·m, 10 N·m).

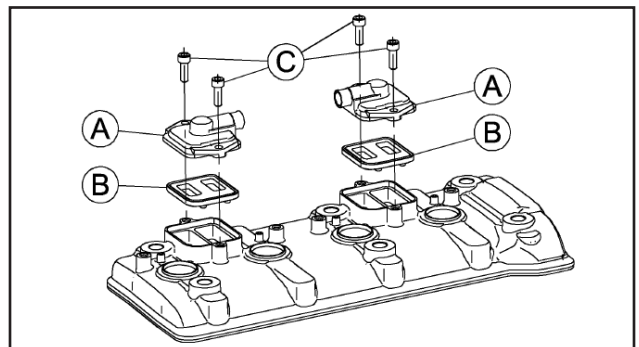
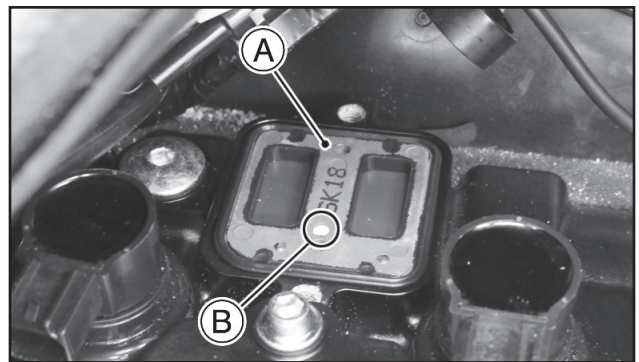
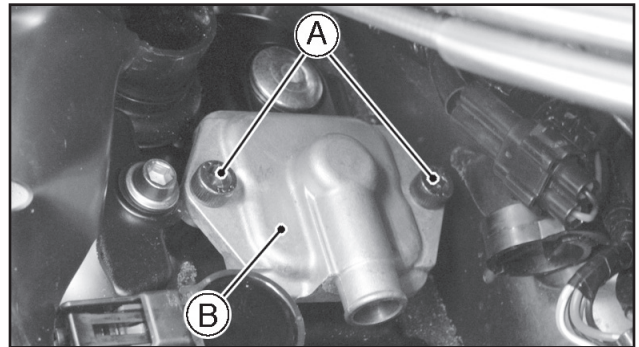
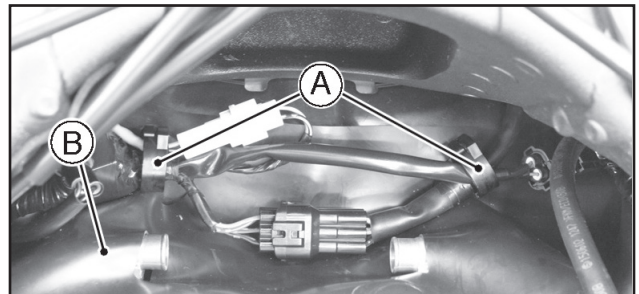

Remove & Replace Reed Valves (cont'd)

Remove Air Suction Valve

- Inspect Parts around the Air Switching Valve and hoses.
- Visually inspect Air Switching Valve [A] and Tubes [B], [C], [D], to include inner and outer areas of the tube.
 - ★ If any of these parts have heat or fire damage, replace them with new parts.

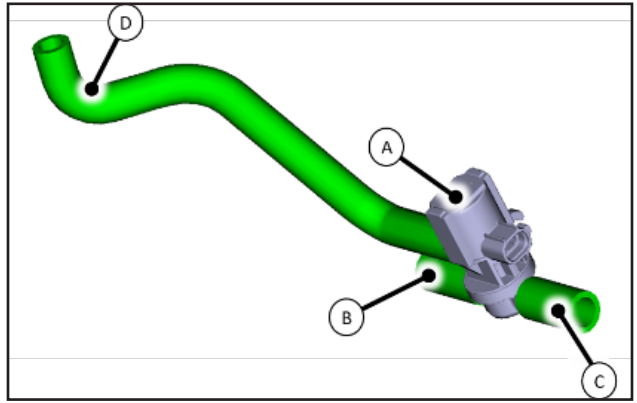

Description	Part No.
Air Suction Valve [A]	Call Dealer Care for Authorization to Replace Parts
Tube [B]	
Tube [C]	
Tube [D]	

- Visually inspect the following parts:
 - Radiator Fan Motor Lead Connector [A],
 - Front Brake Switch Lead Connector [B],
 - Right Housing Assy Control Lead Connector [C],
 - Ignition Coil [D],
 - Harness, Heat Insulation Rubber Plate...etc
- ★ If any of these parts have heat or fire damage, replace them with new parts.

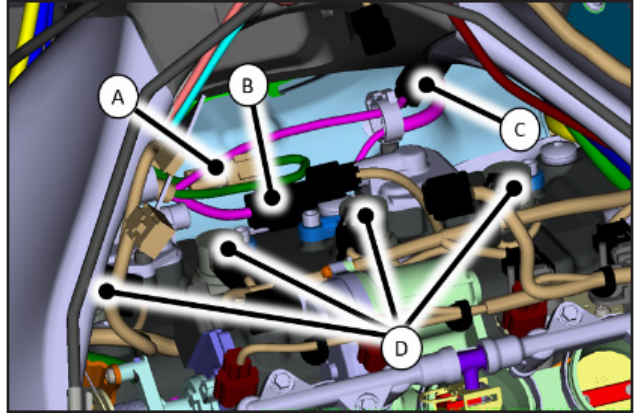

Description	Part No.
Radiator Assembly	Call Dealer Care for Authorization to Replace Parts
Front Brake Switch	
Right-Housing-Assy-Control	
Coil-Assembly-Ignition	
Heat Insulation Rubber Plate	
Harness	
Other Parts not Listed	

Remove & Replace Reed Valves (cont'd)

- Visually inspect the following for damage:
 - Front side of Air Cleaner Housing [A]
 - installation point of air switching valve hose [B]
 - Secondary Fuel Injector [C] for any damage.

★ If any of these parts have heat or fire damage, replace them with new parts.

Description	Part No.
Air Cleaner Housing	Call Dealer Care for Authorization to Replace Parts
Pad	
Secondary Fuel Injector	

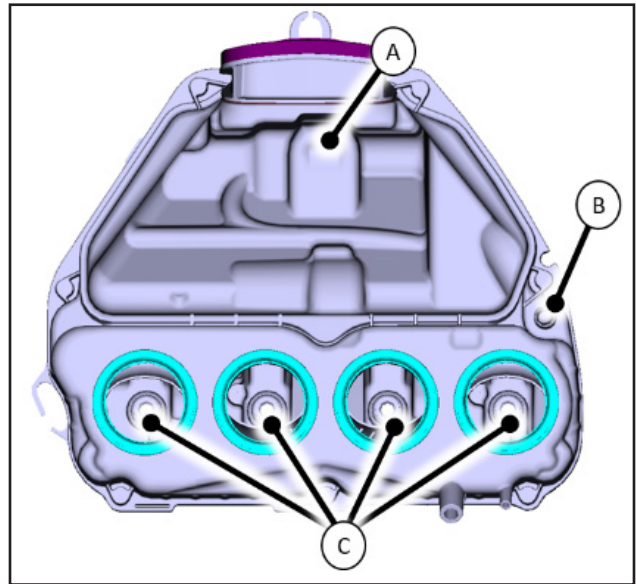

Air Switching Valve Installation

- Install air switching valve [A] with hose [B] as shown.
 - Front [C]
 - Left Side View [D]
 - Yellow Paint [E]

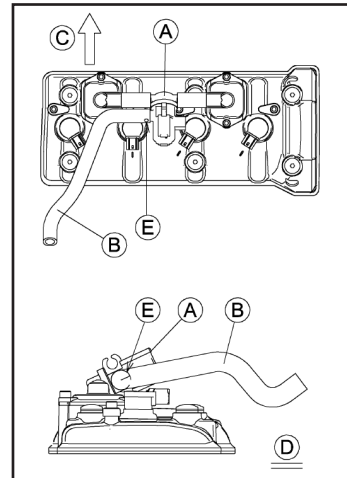

Air Cleaner Housing Installation

- Be sure to install the pad [A].

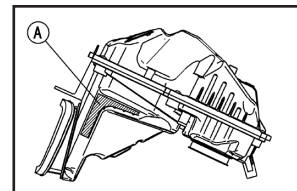

- Install the air cleaner housing clamps [A] so that their bolt heads [B] face inward.
- Install the air cleaner housing [C] to the throttle body assy.
 - Collar [D]
 - Damper [E]
 - Washer [F]
- Be sure the air cleaner housing is inserted to the throttle body assy securely.
- Be sure the hoses are routed correctly and properly installed.
- Tighten air cleaner housing clamp bolts [B] & [G] to 18 in·lb (0.20 kgf·m, 2.0 N·m).

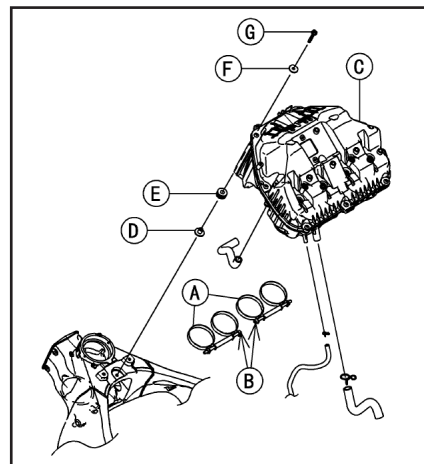

Remove & Replace Reed Valves (cont'd)

- Run the leads and hoses correctly. (See Cable, Wire, and Hose Routing)
 - Rubber Cover (Wrap the turn signal relay and radiator fan relay.) [1]
 - Turn Signal Relay and Radiator Fan Relay [2]
 - Clamps (Hold the secondary fuel injector connector. Install them to the air cleaner housing.) [3]
 - IMU [4]
 - Fuel Tank Breather Hose [5]
 - Clamp (Hold the main harness. Close it after installing the fuel tank breather hose.) [6]
 - Run the fuel tank breather hose in outside of the main harness. [7]
 - Run the fuel tank drain hose to the inside of the breather hose. Run it in front of the fuel hose. [8]
 - Clamp (Hold the fuel hose. After holding the hose with the clamp, take the hose forward and install the fuel tank.) [9]
 - Breather Hose [10]
 - Fuel Tank Drain Hose [11]
 - Fuel Hose [12]
 - Clamp (Hold the secondary fuel injector leads and fuel tank breather hose. Position the hose joint under the clamp. Run the fuel tank breather hose in front of the main harness.) [13]
 - Position the corrugate tube in the clamp. [14]
 - Run the fuel tank breather hose between the rubber boot and air cleaner housing. [15]
 - US and L Models [16]

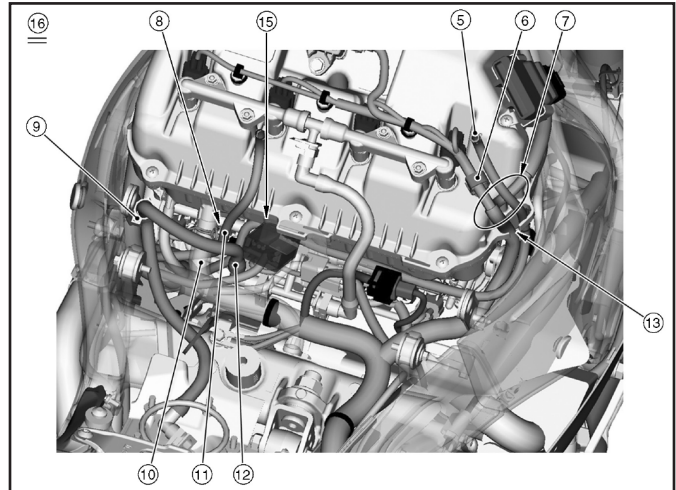
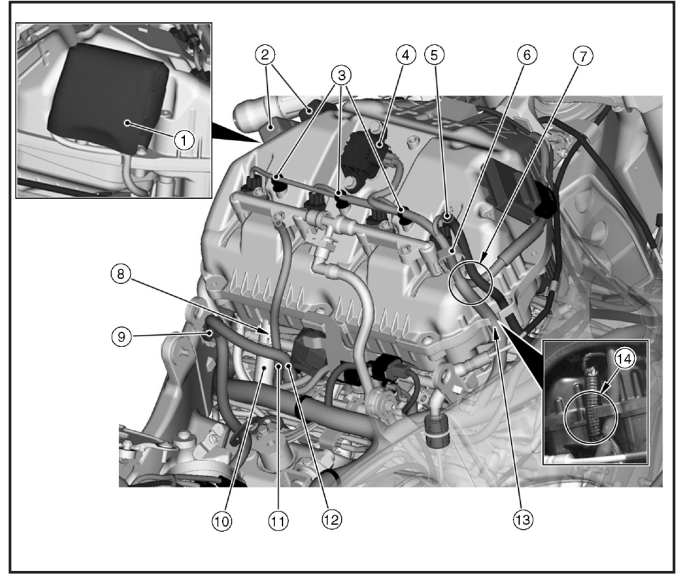

- Install removed parts.
- Start the engine to verify that the engine light is not flashing after completing all repairs.

CALL KAWASAKI DEALER CARE AT (800) 854-3800 FOR AUTHORIZATION OF ADDITIONAL TIME REQUIRED TO COMPLETE REMOVAL AND REPLACEMENT OF DAMAGED PARTS.

Warranty Information

This is a safety Recall campaign. Repair is authorized regardless of ownership or warranty status.

Repairs **MUST BE PERFORMED IMMEDIATELY ON ALL ELIGIBLE UNITS** in the field and during initial assembly and preparation if the inspection reveals a damaged brake hose or sensor wire.

See the Warranty Policies and Procedures Manual (claim type 3 information) for detailed instructions when submitting the Warranty Claim.

	Reprogram Only	Reprogram & Replace Reed Valves	Reprogram & Replace Reed Valves & Replace Heat Damaged Parts
Job Code	22527	22528	22529
Flat Rate Time	0.3	1.4	1.4
Claim Type	3	3	3
Part Number	99999-0766	99999-0766	99999-0766
Description	Kit, Reed Valve MC20-02	Kit, Reed Valve MC20-02	Kit, Reed Valve MC20-02
Quantity	0	1	1
Additional Parts	N/A	N/A	Call Dealer Care at (800) 854-3800 for additional time authorization to remove and replace heat damaged parts

Repair Verification

- Make a white paint mark on the rear edge of the ECU found under the tool kit as shown below to serve as repair verification.

NOTE:

- o *Repair verification is an essential part of the repair procedure. Along with the physical repair verification, check VIP (Vehicle Information Portal) in K-Dealer for other possible repair campaigns for eligible units.*

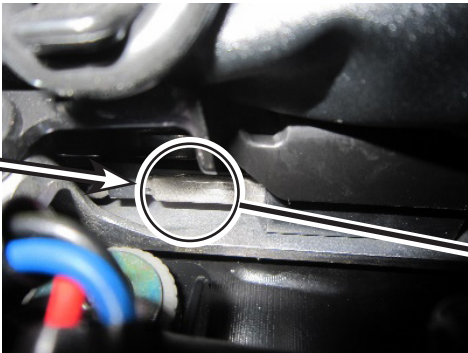
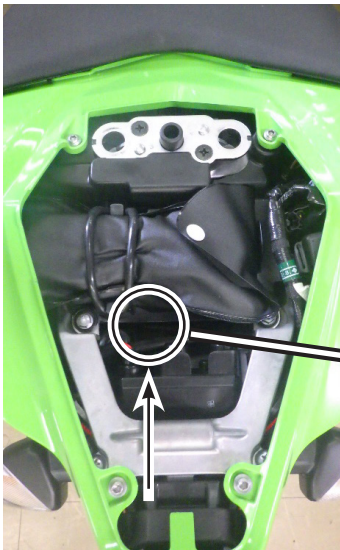

NOTE:

- o ECU removed for clarity only. Do not remove from vehicle.

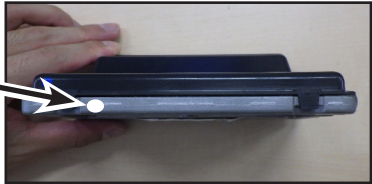

2019 & 2020 NINJA® ZX™-10R, 10RR, 10R ABS, & 10R ABS, & 10R KRT EDITION, ABS KRT EDITION ENGINE BACKFIRE

IMPORTANT SAFETY RECALL NHTSA RECALL NO. 20V-307

Dear Kawasaki Motorcycle Owner:

This notice is sent to you in accordance with the National Traffic and Motor Vehicle Safety Act. Kawasaki Motors Corp., U.S.A., has decided that a defect which relates to motor vehicle safety exists in certain 2019 & 2020 NINJA® ZX™-10R, 10RR, 10R ABS, & 10R KRT EDITION, ABS KRT EDITION models.

The reason for this notice:

On affected units, the engine could backfire while shifting under high engine loads when KQS (Kawasaki Quick Shifter) is activated, potentially resulting in damage to the air suction valve(s). Continued use could result in additional damage to surrounding parts caused by blow back of high temperature exhaust gas and creating the potential for a fire. Our records indicate that you have purchased one of these units.

What Kawasaki and your dealer will do:

Kawasaki has authorized your dealer to reprogram the ECU (Engine Control Unit) on your motorcycle and replace the air suction valve(s). A physical inspection of the area around the air suction valve assembly will also be carried out and repairs completed if required. All repairs will be performed free of charge. The actual repair will take up to one and a half hours but may take longer due to scheduling at the dealership and the time needed to obtain required parts.

What should you do to ensure your safety?

Please call your Kawasaki dealer to schedule an appointment to have your motorcycle inspected and repaired as required. Please have your Vehicle Identification Number (VIN) ready when calling. To locate the nearest authorized Kawasaki motorcycle dealer, please visit www.kawasaki.com and click on the "LOCATE DEALER" link.

If you need help:

If you have questions or concerns that your dealer is not able to resolve, please contact Kawasaki Customer Care at (866) 802-9381 (toll-free) between 7:00 a.m. and 4:00 p.m. PT Monday through Friday. Please have your Vehicle Identification Number ready when calling.

If your dealer fails or is unable to remedy this defect without charge within a reasonable amount of time (60 days after your first attempt to obtain remedy), you may submit a written complaint to the Administrator, National Highway Traffic Safety Administration, 1200 New Jersey Ave. S.E., Washington, D.C. 20590, or call the toll-free Vehicle Safety Hotline at 1(888) 327-4236 (TTY: 1-800-424-9153); or go to <http://www.safercar.gov>.

If you received this notice in error:

Our records indicate you are the current owner of the motorcycle described in this letter. If you no longer have the vehicle described in this letter, please help us to update our records at www.kawasaki.com by clicking on "OWNER CENTER => OWNER SUPPORT => UPDATE OWNER INFO" or by calling Kawasaki toll free at (866) 802-9381. Federal regulation requires that any vehicle lessor receiving this recall notice must forward a copy of this notice to the lessee within ten days.

Reimbursement:

If you have experienced the failure described above prior to receiving this letter and have paid to have it corrected, you may be eligible for full or partial reimbursement for your documented cost of repair(s). To apply for reimbursement, please send copies of current owner and VIN information along with copies of repair orders and payment confirmation to the following address:

Kawasaki Motors Corp., U.S.A.
ATTN: Customer Care
P.O. Box 25252
Santa Ana, California 92799-5252

Please note the following conditions for reimbursement:

Claims may be excluded if proper documentation is not included. Current owner and VIN information along with copies of repair orders and payment confirmation must be provided.

We are sorry for any inconvenience this may cause, but we have taken this action in the interest of your safety and your continued satisfaction with your Kawasaki motorcycle.

Sincerely,

Kawasaki Motors Corp., U.S.A.