

Product Safety Recall

N202303140 Brake Line Routing



Release Date: May 2020

Revision: 00

Revision Description: This bulletin is being revised to update the service procedure. Please discard all previous copies of bulletin N202303140.

Attention: It is a violation of Federal law for a dealer to deliver a new motor vehicle or any new or used item of motor vehicle equipment (including a tire) covered by this notification under a sale or lease until the defect or noncompliance is remedied.

Dealers were notified of this safety recall and the pass or fail functional inspection procedure on April 3, 2020. This bulletin contains an inspection procedure for both dealer inventory and customer vehicles. Vehicles that pass this inspection procedure can be delivered and closed using the “Inspect Brake Pipe Clips – Inspection Passed-No Further Action Required” labor code 9104672. For those vehicles that do not pass functional inspection, once the service procedure contained in this revised bulletin has been performed on the vehicle, it can be released from stop delivery and the vehicle can be delivered to the customer.

All involved vehicles that are in dealer inventory must be held and not delivered to customers, dealer traded, or used for demonstration purposes until the repair contained in this bulletin has been performed on the vehicle.

ONLY Chevrolet Medium Duty dealers can complete this recall repair.

Make	Model	Model Year		RPO	Description
		From	To		
Chevrolet	Low Cab Forward 4500	2019	2019		

Involved vehicles are marked Open on the Investigate Vehicle History screen in GM Global Warranty Management system. This site should always be checked to confirm vehicle involvement prior to beginning any required inspections and/or repairs.

Condition	Isuzu Motors Limited, manufacturer of 2019 Chevrolet Low Cab Forward 4500 medium duty vehicles has decided that a defect, which relates to motor vehicle safety, exists in these vehicles. In some of the affected vehicles, the brake line clip(s) for the rear driver side brake line (which is routed inside the passenger side frame rail) may have been incorrectly installed, potentially allowing the brake line to make contact with a grounding bolt. Repeated contact with the bolt could compromise the rear driver side brake line, leading to a loss of brake fluid and resulting in a drop in the hydraulic brake pressure and a reduction or loss of the rear driver side braking performance. All of the remaining brakes (front, passenger side rear and parking brake) will continue to operate normally. If the rear driver side brake fails, the braking performance of the vehicle can be reduced, increasing the risk of a crash.
Correction	Dealers will inspect the brake line mounting clips of affected vehicles in their inventory (if applicable) to determine if the brake line clip(s) were installed correctly per the inspection procedure provided in this bulletin. This service will be performed free of charge. If the clips are not installed correctly, the brake line will have to be replaced.

Parts

Quantity	Part Name	Part No.
1	Pipe Asm, 4/5/6 Way	98382769
6	Clip; Pipe L	94316410
2	Clip; Pipe, Brk	97326158
1	Clip; Brake & Clutch Pipe	94146043

Important: Parts should only be ordered when inspection determines that it is necessary to replace.

It is estimated that only 54 involved vehicles will require parts replaced. **Due to the small number of vehicles anticipated that will need this fix and the limited initial parts availability, dealers are encouraged not to order these parts for use as shelf stock.**

Reminder: Parts may be removed from Retail Inventory Management (RIM). Dealers should review the affected parts to confirm RIM managed status. Parts may have quantity limiters in effect.

Product Safety Recall

N202303140 Brake Line Routing



Warranty Information

Labor Operation	Description	Labor Time	Trans. Type	Net Item
9104672	Inspect Brake Pipe Clips – Inspection Passed-No Further Action Required	0.3	ZFAT	N/A
9105085	Rear Driver Side Brake Line Replacement	1.4	ZFAT	N/A
	Add Time: Inspection (if not previously claimed)	0.3		
9105144	Floor Plan Reimbursement – NEW INVENTORY ONLY	N/A	ZFAT	*
9105145	Working Capital Assistance Program Reimbursement – USED INVENTORY ONLY	N/A	ZFAT	**

Floor Plan Reimbursement – NEW INVENTORY ONLY

* **USA Only** – For vehicles eligible for floor plan reimbursement, the amount should be submitted in Net Item/Miscellaneous. This amount should represent the product of the vehicle's average daily interest rate (see table below) multiplied by the actual number of days the vehicle was in dealer inventory and not available for sale. This reimbursement is limited to the number of days from the date of the stop delivery message (April 3, 2020) to the date the repair is completed, and the vehicle is ready for sale (not to exceed 45 days):

Vehicle	Floor Plan Reimbursement Amount
	USA
2019 Chevrolet Low Cab Forward 4500	\$4.81

Working Capital Assistance Program (WCAP) Reimbursement – USED INVENTORY ONLY

Note: USA Only - To avoid having to "H" route the WCAP transaction for approval, it must be submitted prior to the repair transaction.

Important: The WCAP ZSET transaction labor code, 9800051, provided in the dealer message sent on May 12, 2020 (USA), must have been submitted prior to the submittal of the ZFAT transaction labor code or the claim will reject.

** **USA Dealers Only** - For vehicles eligible under the Working Capital Assistance Program, the amount should be submitted in Net Item/Miscellaneous. This amount has been calculated to a daily value for the days that the vehicle was in used dealer inventory and not available for sale. This reimbursement is limited to the number of days from the date of the stop sale/stop delivery order (April 3, 2020) to the date the inspection or repair closed the recall bulletin. (not to exceed 45 days).

Vehicle	Working Capital Assistance Reimbursement Amount
	USA
2019 Chevrolet Low Cab Forward 4500	\$19.93

Service Procedure

1. Shift vehicle to park, turn off engine, set parking brake, and block rear wheels.

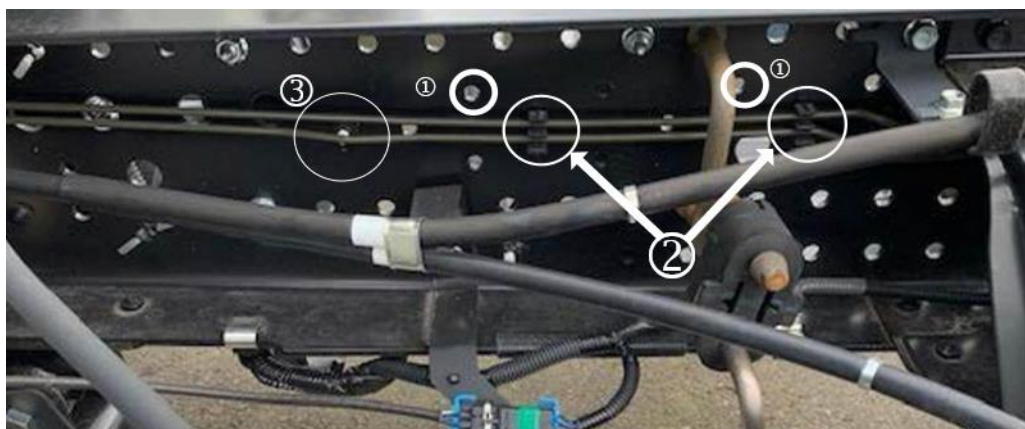

5577618

Product Safety Recall

N202303140 Brake Line Routing



2. Inspect for the proper brake pipe clip placement on the inside of the Right Hand Frame Channel, directly above the Number 1 Oxygen Sensor Connector Bracket. If the pipe clip has been installed in the correct location (1), no further action required. If the pipe clip is installed in the incorrect location (2), with brake line to grounding bolt interference, proceed to Step 3.
3. Remove the front lower grille. Remove the ABS module cover.

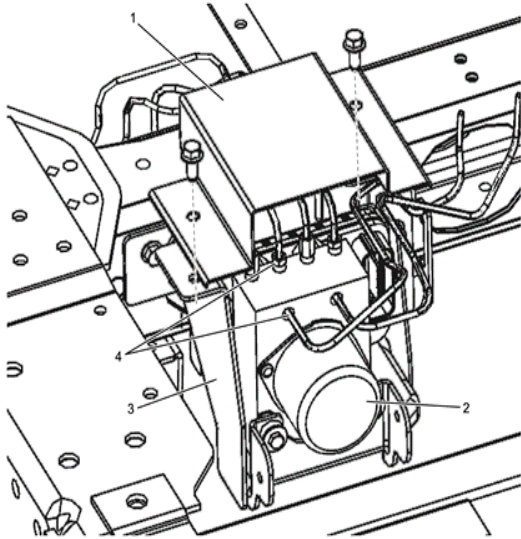

5587402

4. Remove the ABS module cover.
5. Tilt the cab upwards and install safety pin.



5587405

6. Remove the tie straps shown above holding the PCV vent line to the air cleaner outlet duct. Set aside the tie straps for reuse later.

Product Safety Recall N202303140 Brake Line Routing

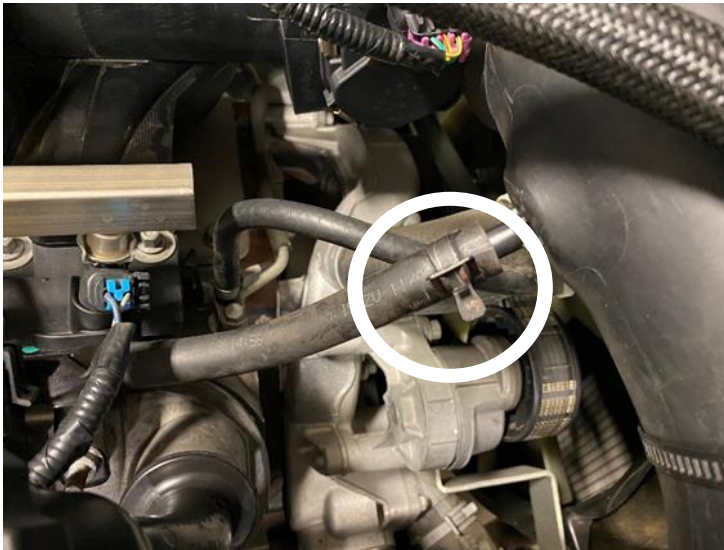

5587407

7. Disconnect the PCV hose from the air intake duct.
8. Remove the two (2) bolts, two (2) hose clamps, and the MAF Sensor wire clamp to remove the complete Air Intake Duct Assembly. Set aside for reuse later.

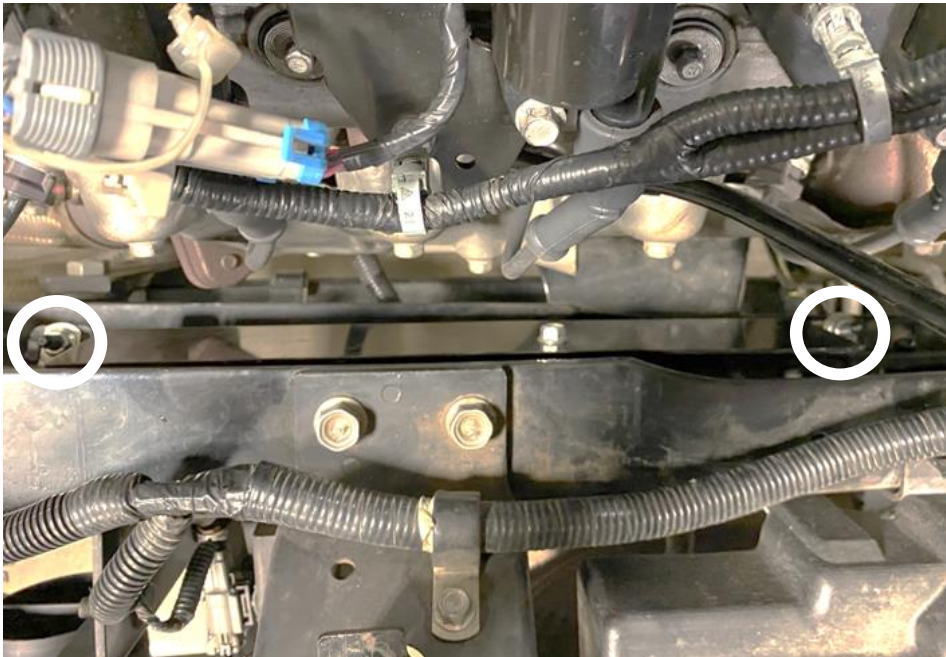

5587409

9. Remove the two nuts holding the shift and parking brake cable clamps onto the right side frame mounted heat shield shown above. Remove the clamps from the studs but leave the clamps wrapped around the cables.

Product Safety Recall

N202303140 Brake Line Routing



5587410

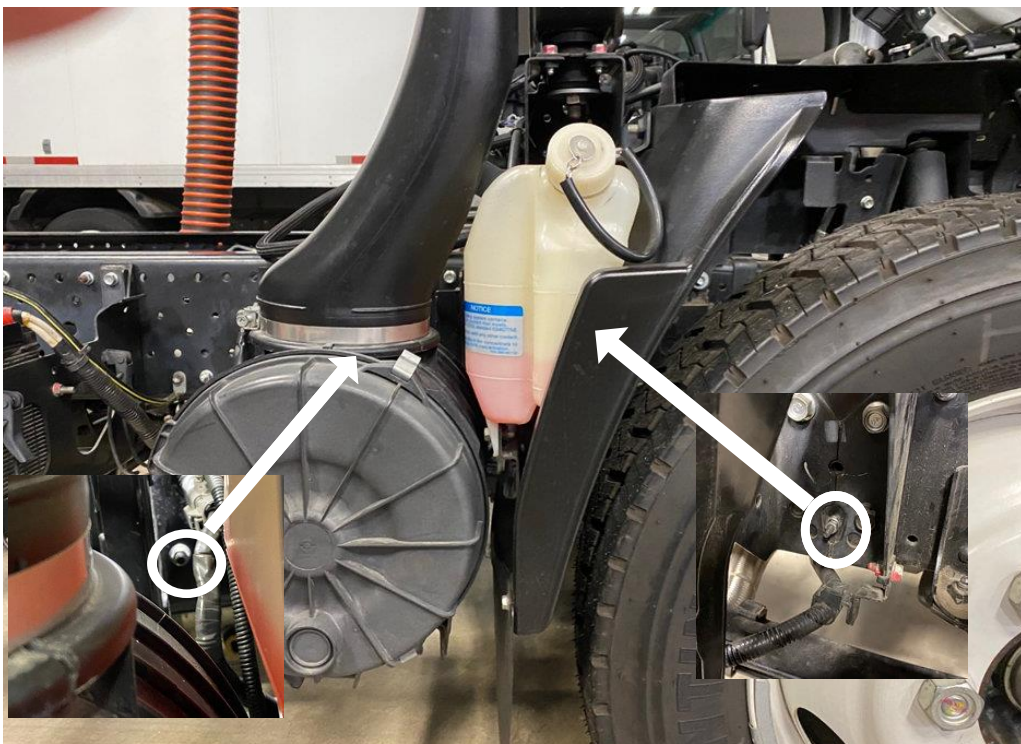

5587411

10. Remove the right side frame mounted heat shield by taking off one 12mm bolt from inside the frame rail. Then remove the one 12mm nut on the outside of the frame rail, along with the one 10mm nut and lock washer on the outside of the frame rail. Move the heat shield to the rear and downward to remove it from the frame. Set aside for later reuse.

Product Safety Recall

N202303140 Brake Line Routing

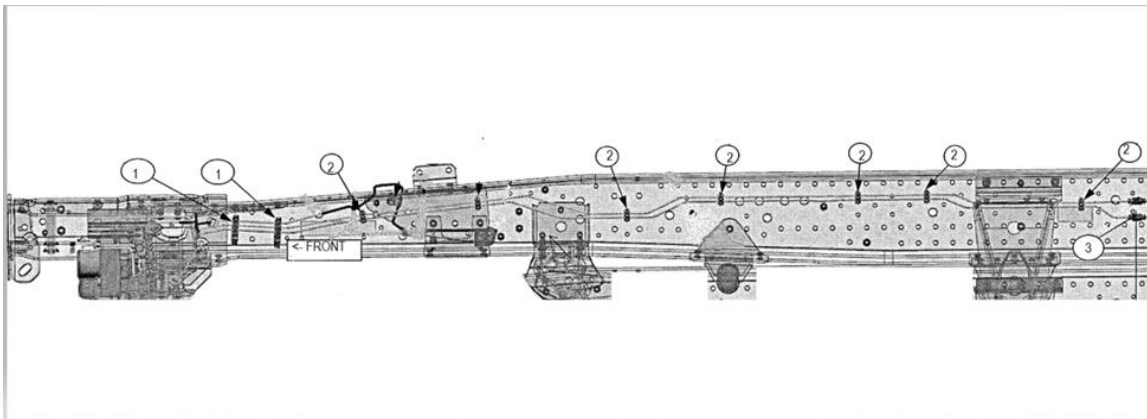

5587414

- (1) Large White Pipe Clip
- (2) Small Grey or Black Pipe Clip
- (3) Brake Pipe Union Joint

11. Make note of the proper type and locations for the 7 plastic clips securing the brake line. Use a paint pen or caulk to draw a circle around each clip hole on the outside of the frame. (See Figure 9.)

Important: Do not scratch the brake pipes when removing the plastic clips.



5587415

- 12. Remove the brake line separator clip directly behind the ABS EHCU shown above. The clip can be broken while removing it, as it will be replaced with a new clip.
- 13. Remove the 7 plastic clips securing the brake lines the brake lines to the frame one at a time. The clips may be broken when removing them. Replace each clip with the same type of new clip as each old one is removed. Ensure that each new clip is installed in the correct location with the correct (original) orientation. Ensure that the pipe clip that was originally installed in the incorrect location is newly installed in the proper location. (See Figures 1 and 2.).
- 14. Snap the two (2) upper brake lines into the clips in their original location on the two (2) white clips. Continue to snap the upper brake line into the remaining five (5) clips in its original location on each one.

Note: Do not snap the lowest brake line into any of the clips at this point, as this is the brake line that is being replaced.

- 15. Place drip pans underneath the ABS EHCU and the Brake Line Union Fitting half way down the right side of the frame.

Product Safety Recall

N202303140 Brake Line Routing

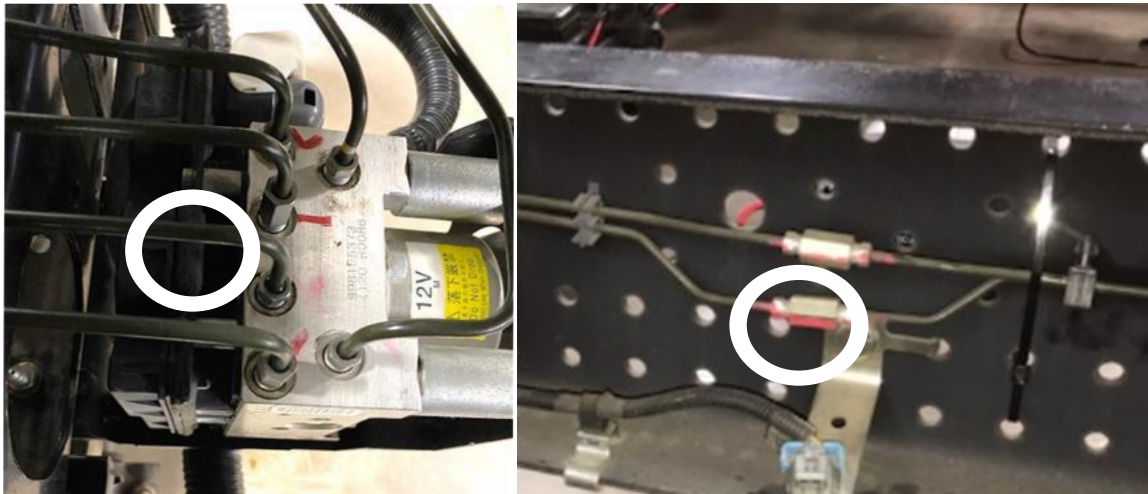

16. Use a 10mm line wrench to loosen the flare nuts for the Right Hand Side, Bottom brake line at the ABS EHCU and the Brake Line Union Fitting (hold the union fitting with a 14mm open end wrench as necessary).
17. Use a 10mm open end wrench to remove the flare nuts from the ABS Actuator and the Union Fitting.
18. Remove the safety pin and lower the cab.
19. Remove the brake line by carefully bringing it forward from the ABS Actuator through the opening where the front grill was removed.
20. With the cab still lowered, insert the new brake line/pipe assembly through the open area of the removed grill. Reverse the process that was used in Step 18 to carefully route the pipe into position. Do not bend or kink the pipe. Ensure that the pipe is properly routed inside the frame channel before attaching it to any clips, the ABS EHCU, or the Union Fitting.
21. Raise the cab and install the safety pin.
22. Start each of the 10mm flare nuts on the new pipe assembly a few turns by hand into the ABS Actuator and the Union Fitting. Snap the new brake line/pipe assembly into the 8 frame mounted clips in the appropriate slot.
23. Use a 10mm open end wrench to tighten the 10mm flare nuts down snugly into the ABS Actuator and the Union Fitting.
24. Use a 10mm crow's foot and a torque wrench to tighten both flare nuts to 16 N•m (12 lb ft). Use a 14mm open end wrench to hold the Union Fitting steady while tightening the flare nut as necessary.
25. Attach new plastic separating clip on the brake lines near the rear of the ABS EHCU. Position the new clip in the same location as it was before removing it in Step 11. (See Figure 10).
26. Install the ABS Module cover (2 bolts). Tighten the bolts to 20 N•m (15 lb ft).
27. Install the frame mounted heat shield removed in Step 10. Tighten the 12 mm nut and bolt to 16 N•m (12 lb ft). Tighten the 10mm nut to 6 N•m (53 lb in).
28. Install the two (2) clamps holding the brake and shifter cables to the right hand frame heat shield. Install the two (2) 12mm nuts in place on the clamp studs and tighten the nuts to 16 N•m (12 lb ft). (See Figure 6).
29. Install the Air Intake Duct Assembly. Install the two (2) 12mm mounting bolts and tighten to 16 N•m (12 lb ft). Tighten the two (2) hose clamps on either end of the Intake Tube Assembly. Install the MAF Sensor wire clamp back into the Air Intake Duct.
30. Install the tie straps (4) holding the PCV vent line to the Air Intake Duct. (See Figure 2).
31. Remove the safety pin and lower the cab.
32. Install the front lower grill (1 Phillips screw and clips).

Caution: Air bleeding without starting the engine will result in damage to the brake booster. Be sure to remove the ABS 60A [FL-11] fuse. Be sure to replace the fuse when the air bleeding procedure is complete.

Product Safety Recall

N202303140 Brake Line Routing

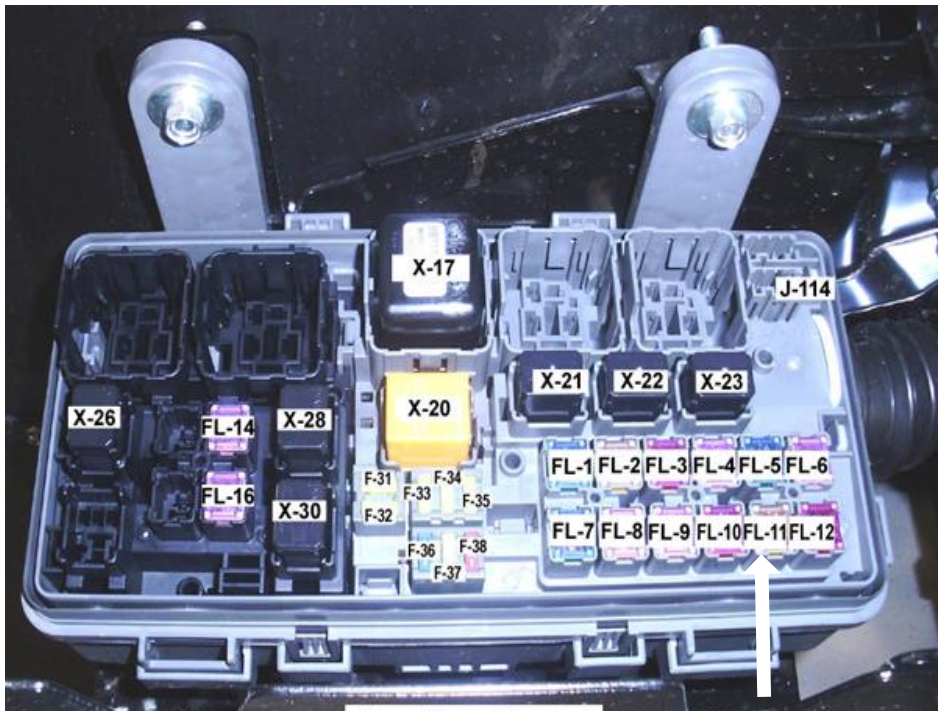

5587418

33. Remove the ABS FL-11 Fuse.



5587419

34. Fill the reservoir with recommended brake fluid and keep at least one-half full of fluid during the bleeding operation.
35. Remove the bleeder screw valve cap at the Left-Rear Wheel.

Product Safety Recall

N202303140 Brake Line Routing

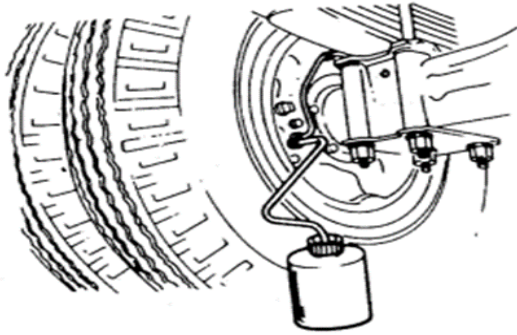

5587420

36. Place a 10mm box end wrench over the bleeder screw, attach a hose over the screw and allow the end to hang in a glass jar containing enough brake fluid to cover the end of the hose.
37. Start the engine.

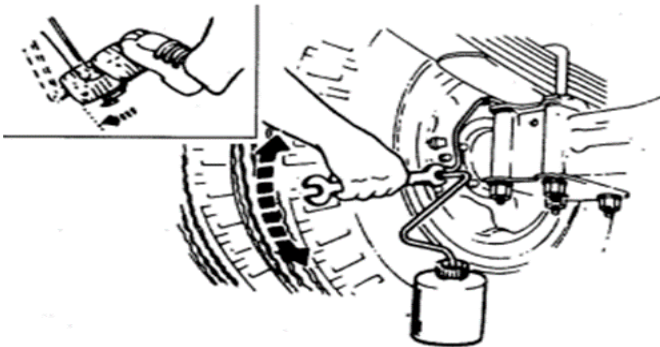

5587422

38. Open the bleeder screw about one-half turn and fully depress the brake pedal. Observe flow from the hose.
39. Close the bleeder screw as soon as bubbles stop and the fluid flows in a solid stream. Release the brake pedal after closing the bleeder screw.
40. Replace the bleeder cap.
41. Turn off the engine.
42. Tilt the cab upwards and install the safety pin.
43. Inspect for leaks on the brake line/pipe just replaced. Use a shop towel and solvent to remove any residual brake fluid.
44. Lower the cab and properly secure the tilt lock mechanism.
45. Reinstall the ABS fuse previously removed.
46. Ensure the brake fluid reservoir is properly filled.
47. Start the engine and inspect for any brake or ABS warning lights.
48. With the engine running, check for proper pedal height and pressure while depressing the brake pedal. Carefully check the brake operation at low speed for before test driving.

Product Safety Recall

N202303140 Brake Line Routing



Dealer Responsibility – For USA & Export (USA States, Territories, and Possessions)

It is a violation of Federal law for a dealer to deliver a new motor vehicle or any new or used item of motor vehicle equipment (including a tire) covered by this notification under a sale or lease until the defect or noncompliance is remedied.

The US National Traffic and Motor Vehicle Safety Act provides that each vehicle that is subject to a recall of this type must be adequately repaired within a reasonable time after the customer has tendered it for repair. A failure to repair within sixty days after tender of a vehicle is prima facie evidence of failure to repair within a reasonable time. If the condition is not adequately repaired within a reasonable time, the customer may be entitled to an identical or reasonably equivalent vehicle at no charge or to a refund of the purchase price less a reasonable allowance for depreciation. To avoid having to provide these burdensome remedies, every effort must be made to promptly schedule an appointment with each customer and to repair their vehicle as soon as possible. In the recall notification letters, customers are told how to contact the US National Highway Traffic Safety Administration if the recall is not completed within a reasonable time.

Dealer Responsibility – All

All new, used, GM Certified Used, courtesy transportation vehicles, dealer shuttle vehicles, etc. in dealers' possession and subject to this recall must be held and inspected/repaired per the service procedure of this bulletin before customers take possession of these vehicles. Involved vehicles must be held and not delivered to customers, dealer-traded, released to auction, used for demonstration, or any other purpose.

All GM Certified Used vehicles currently in the dealers' inventory within the Certified Pre-Owned Inventory System (CPOIS) will be de-certified and must be held and remedied per the service procedure in this bulletin. Upon submitting an accepted/paid warranty transaction in the Global Warranty Management (GWM) system, the vehicle can be re-certified for sale within the CPOIS system, or once again be used in the CTP program.

Dealers are to service all vehicles subject to this recall at no charge to customers, regardless of mileage, age of vehicle, or ownership, from this time forward.

Customers who have recently purchased vehicles sold from your vehicle inventory, and for which there is no customer information indicated on the dealer listing, are to be contacted by the dealer. Arrangements are to be made to make the required correction according to the instructions contained in this bulletin. A copy of the customer letter is provided in this bulletin for your use in contacting customers. Recall follow-up cards should not be used for this purpose, since the customer may not as yet have received the notification letter.

In summary, whenever a vehicle subject to this field action enters your vehicle inventory you must take the steps necessary to ensure the program correction has been made before selling the vehicle. In addition, for vehicles entering your facility for service, you are required to ensure the customer is aware of the open field action and make every reasonable effort to implement the program correction as set forth in this bulletin prior to releasing the vehicle.

Dealer Reports

For dealers with involved vehicles, a listing with involved vehicles has been prepared and will be provided to U.S. and Canadian dealers through the GM GlobalConnect Recall Reports or sent directly to export dealers. The listing may contain customer names and addresses obtained from Motor Vehicle Registration Records. The use of such motor vehicle registration data for any purpose other than follow-up necessary to complete this recall is a violation of law in several states/provinces/countries. Accordingly, you are urged to limit the use of this report to the follow-up necessary to complete this recall.

Customer Notification

USA & Canada - General Motors will notify customers of this recall on their vehicle. (see copy of customer letter included with this bulletin).

GM bulletins are intended for use by professional technicians, NOT a "do-it-yourselfer". They are written to inform these technicians of conditions that may occur on some vehicles, or to provide information that could assist in the proper service of a vehicle. Properly trained technicians have the tools, equipment, safety instructions, and know-how to do a job properly and safely. If a condition is described, **DO NOT** assume that the bulletin applies to your vehicle, or that your vehicle will have that condition. See your dealer for information on whether your vehicle may benefit from the information.



**We Support
Voluntary Technician
Certification**



IMPORTANT SAFETY RECALL

May 2020

This notice applies to your vehicle, VIN: _____

Dear General Motors Customer:

This notice is sent to you in accordance with the National Traffic and Motor Vehicle Safety Act.

General Motors has decided that a defect, which relates to motor vehicle safety, exists in certain 2019 model year Chevrolet Low Cab Forward 4500 vehicles. As a result, GM is conducting a safety recall. We apologize for this inconvenience. However, we are concerned about your safety and continued satisfaction with our products.

IMPORTANT

- Your vehicle is involved in GM safety recall N202303140.
- Schedule an appointment with your GM dealer.
- This service will be performed for you at **no charge**.

Why is your vehicle being recalled?

Isuzu Motors Limited, manufacturer of 2019 Chevrolet Low Cab Forward 4500 medium duty vehicles has decided that a defect, which relates to motor vehicle safety, exists in these vehicles. In some of the affected vehicles, the brake line clip(s) for the rear driver side brake line (which is routed inside the passenger side frame rail) may have been incorrectly installed, potentially allowing the brake line to make contact with a grounding bolt. Repeated contact with the bolt could compromise the rear driver side brake line, leading to a loss of brake fluid and resulting in a drop in the hydraulic brake pressure and a reduction or loss of the rear driver side braking performance. All of the remaining brakes (front, passenger side rear and parking brake) will continue to operate normally. If the rear driver side brake fails, the braking performance of the vehicle can be reduced, increasing the risk of a crash.

What will we do?

Your GM dealer will inspect the brake line mounting clips to determine if the brake line clip(s) were installed correctly. If the clips are not installed correctly, the brake line will have to be replaced. This service will be performed for you at **no charge**. Because of service scheduling requirements, it is likely that your dealer will need your vehicle longer than the actual inspection and service correction time of approximately two hours.

Do you have questions?

If you have questions or concerns that your dealer is unable to resolve, please contact the appropriate Customer Assistance Center at the number listed below.

Division	Number	Text Telephones (TTY)
Puerto Rico – English	1-800-496-9992	
Puerto Rico – Español	1-800-496-9993	
Virgin Islands	1-800-496-9994	
GM Medium Duty Truck	1-800-862-4389	

If after contacting your dealer and the Customer Assistance Center, you are still not satisfied we have done our best to remedy this condition without charge and within a reasonable time, you may wish to write the Administrator, National Highway Traffic Safety Administration, 1200 New Jersey Avenue, SE, Washington, DC 20590, or call the toll-free Vehicle Safety Hotline at 1.888.327.4236 (TTY 1.800.424.9153), or go to <http://www.safercar.gov>. The National Highway Traffic Safety Administration Campaign ID Number for this recall is 20V193.

Federal regulation requires that any vehicle lessor receiving this recall notice must forward a copy of this notice to the lessee within ten days.

Product Safety Recall
N202303140 Brake Line Routing



Maryann L. Combs
Vice President
Global Vehicle Safety

GM Recall: N202303140