



SIB 72 03 20

2020-03-18

RECALL 20V-XXX: FRONT SEAT BELT BUCKLES

Please perform the procedure outlined in this Service Information on all affected vehicles before customer delivery. In the event the customer has already taken delivery of the vehicle, please perform the procedure the next time the vehicle is in the shop.

This Service Information Bulletin (Revision 1) replaces SI B72 03 20 **dated March 2020**.

What's New (Specific text highlighted):

Entire content except Model, Affected Vehicles, Situation

MODEL

E-Series	Model Description	Production Date
F91	M8 Convertible	February 11, 2020 – March 4, 2020
F92	M8 Coupe	February 11, 2020 – March 2, 2020
F93	M8 Gran Coupe	February 7, 2020 – March 4, 2020
F97	X3 M Sports Activity Vehicle	January 15, 2020 – February 14, 2020
F98	X4 M Sports Activity Coupe	January 15, 2020 – February 14, 2020
G01	X3 Sports Activity Vehicle	January 15, 2020 – February 17, 2020
G02	X4 Sports Activity Coupe	January 15, 2020 – February 17, 2020
G14	8 Series Convertible	February 7, 2020 – March 4, 2020
G15	8 Series Coupe	February 10, 2020 – March 4, 2020
G16	8 Series Gran Coupe	January 29, 2020 – March 4, 2020
G20	3 Series Sedan	January 28, 2020 – February 18, 2020

AFFECTED VEHICLES

Vehicles which require this Recall Campaign to be completed will show it as "Open" when checked either in AIR, the "Service Menu" of DCSnet (Dealer Communication System), ISPA Next or Warranty Vehicle Inquiry.

SITUATION

BMW AG is conducting a Voluntary Safety Recall (effective March 13, 2020) on certain Model Year 2020 BMW vehicles that were produced between January 15, 2020 and March 4, 2020. The issue involves the hall sensor within the driver and/or passenger front seat safety belt buckle.

CAUSE

Within the safety belt, the hall effect sensor for the safety belt buckle status may read incorrectly.

CORRECTION

Perform a stress test on each front seat's safety belt buckle.

If the hall sensor fails to remain within 3 mm of the underside of the safety belt buckle after the test, the buckle assembly must be replaced.

PROCEDURE

1. Place the front seat height at the lowest position.

2. Bend the buckle head 5 times towards the seat cushion to create a 90-degree bend of the buckle cable.

The safety belt is shown latched into the buckle but is not necessary. The belt end simply increases leverage.



Inspect the bottom of the buckle. If needed for better access, bend the buckle forward. The hall switch connection is at the arrow.



Verify visually if the hall switch remains in the correct position.



If there is a visual gap between the hall switch assembly and the buckle, replace the part.

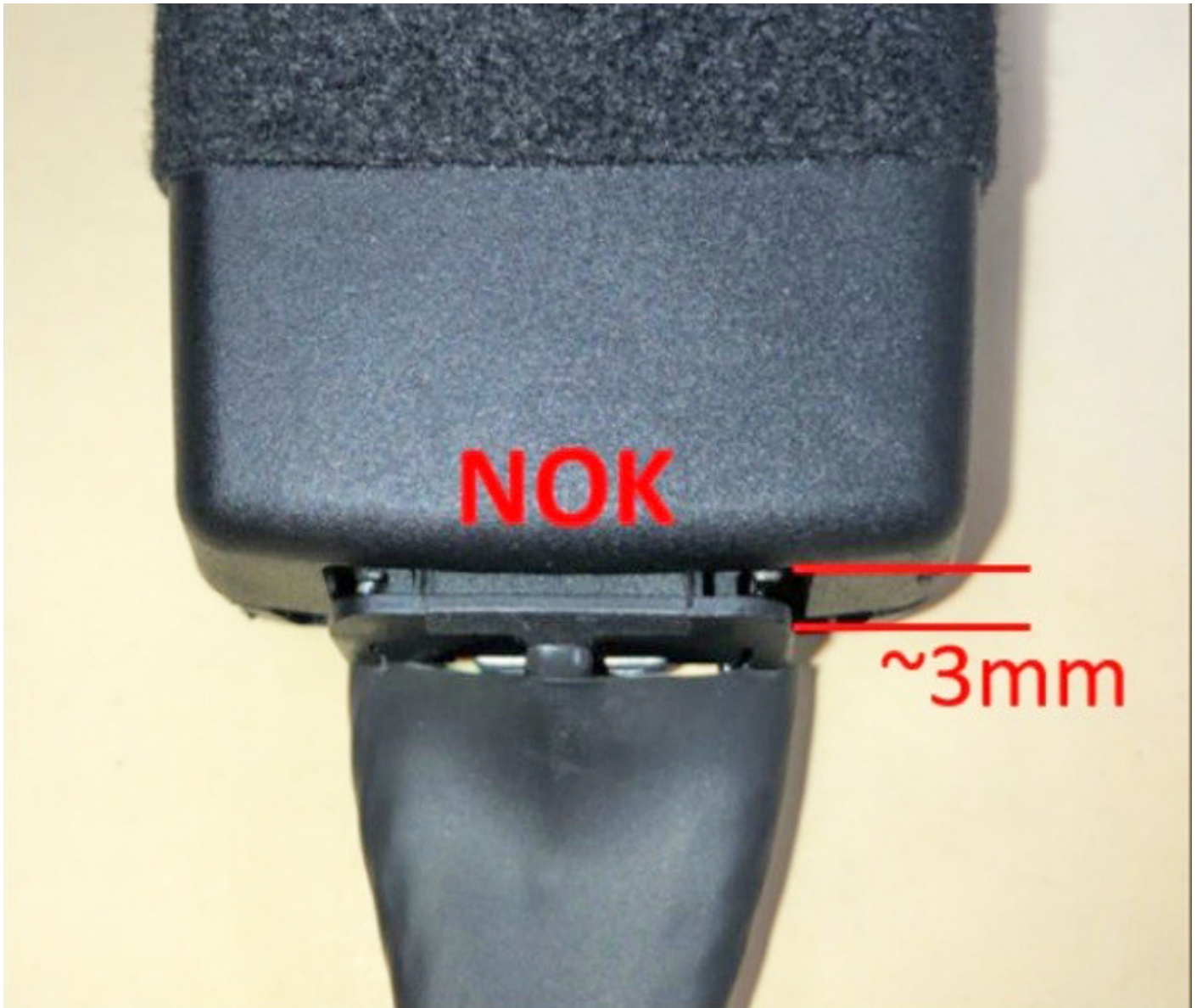

3. Perform the test on the other front buckle.

Side-by-side comparison:

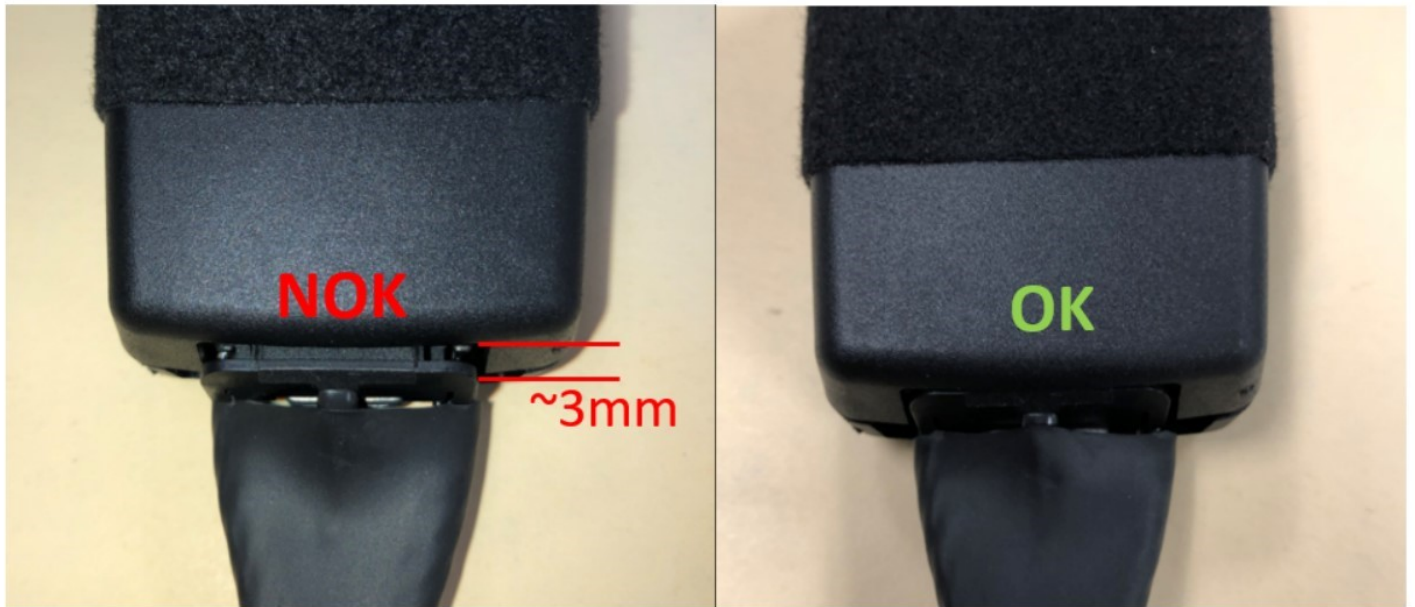

Attachments are enclosed for the models' AIR repair procedures as guidelines. Refer to AIR for the latest repair versions and tightening torque values.

PARTS INFORMATION

Only use and invoice the part numbers below that apply.

Performing a part number look-up in ETK (EPC) by VIN or model in place of using/invoicing the following part numbers may result with the wrong part numbers being invoiced and installed, this could delay the payment of claim.

Part Number	Description	Quantity
72 11 7 414 301	Seat Belt Buckle, front	Max of 2 for all vehicles
AND		
07 14 9 321 690	Screw M10x28	8 for all vehicles
AND		
72 11 9 909 471	Screw M10x16	4 (G01, G02, F97, F98)
OR		
07 11 9 908 419	Screw M10x16	4 (G20, G14, G15, G16, F91, F92, F93)

WARRANTY INFORMATION

Vehicles that Passed Recall/Delivery Stop Inspection Procedure

You will need to have the repair order (RO) number and the RO close date to retail (RDR) an affected vehicle that **passed** the inspection.

B72 03 20: Recall Flat Rate Labor Operation Codes – Current Status

The special flat rate labor operation codes (Main and Plus) for this Recall/Delivery Stop repair will be available shortly.

Temporary labor operation code 72 99 000, below, is only a place holder for repair order invoicing an **inspection, no repair is necessary** work procedure on an affected vehicle.

Please DO NOT USE temporary labor operation code 72 99 000 for claim submission.

Vehicles that do not pass the inspection cannot be retailed until the final repair and claim information is available and performed.

The special Defect Code and the corresponding special flat rate labor operation code, when these labor codes become available, **must** be used for this Recall claim submission.

Defect Code:	0072130200	
---------------------	-------------------	--

Completion before the first vehicle delivery to a customer or the vehicle is already in the workshop

Work Pkg	Labor Operation	Description:	Labor Allowance
T1	72 99 000	Perform stress test on the safety belt buckles (No repair is necessary) (Plus work, do not use labor op 72 99 000 for claim submission)	3 FRU

Or:

The vehicle arrives at your center and this Recall Campaign shows open (No other Main work will be performed/claimed during this workshop visit)

Work Pkg	Labor Operation	Description:	Labor Allowance
T2	72 99 000	Perform stress test on the safety belt buckles (No repair is necessary) (Main work, do not use labor op 72 99 000 for claim submission)	4 FRU

Supporting Materials

[picture_as_pdf B720320_G14 F91 REP.pdf](#)

[picture_as_pdf B720320_G20 REP.pdf](#)

[picture_as_pdf B720320_G02 F98 REP.pdf](#)

[picture_as_pdf B720320_G15 F92 REP.pdf](#)

[picture_as_pdf B720320 Recall Notice.pdf](#)

[picture_as_pdf B720320_2020-VariousModels-SafetyBeltBuckleSensor-QA-\(13Mar2020\).pdf](#)

[picture_as_pdf B720320_G01 F97 REP.pdf](#)

[picture_as_pdf B720320_G16 F93 REP.pdf](#)

SAFETY RECALL NOTICE

To: All Center Operators, Sales Managers, Service Manager, Parts Manager and Warranty Processor

RE: Recall 20V-xxx: Front Seat Belt Buckles – B72 03 20

BMW AG is conducting a Voluntary Safety Recall (effective March 13, 2020) on certain Model Year 2020 BMW vehicles that were produced between January 15, 2020 and March 4, 2020.

Please be reminded that it is a violation of federal law (The Safety Act) for you to sell, lease or deliver any new motor vehicle covered by this notification until the recall repair has been performed. This means that centers may not legally deliver new motor vehicles to consumers until they are fixed or use/sell replacement equipment/parts subject to this recall. Note also that substantial civil penalties apply to violations of the Safety Act.

Also, you should not sell, lease or deliver any Certified Pre-Owned or used vehicles subject to a safety recall until the repair is completed.

Please follow any special instructions that we provide to you for the return or disposition of recall parts.

We appreciate all your assistance with this Recall.

**Front Seat Safety Belt Buckle Sensor
Safety Recall 20V-xyz
Model Year 2020
BMW 3 Series, 8 Series, X3 SAV, X4 SAC
*Last Updated 03/13/2020***

- Q1. Which BMW Group models in the US are potentially affected by this Safety Recall?**
Certain Model Year 2020 BMW 3 Series, 8 Series (including M8), X3/X3M SAV, and X4/X4M SAC vehicles in the US, produced between January and March 2020, are potentially affected.
- Q2. What is the specific issue?**
The driver and passenger front seat safety belt buckles have a sensor to detect whether or not the belt is buckled. Potentially affected vehicles may have an incorrect buckle sensor. In such a case, the system may erroneously detect a belted condition as unbelted and display the safety belt warning symbol in the instrument cluster.
- Q3. Why are other BMW Group vehicles not included in this Safety Recall?**
Other vehicles were equipped with the appropriate front seat safety belt buckle sensors.
- Q4. How did BMW Group become aware of this issue?**
BMW Group became aware of this issue through its quality control procedures.
- Q5. Can I determine if this issue exists in my vehicle?**
No.
- Q6. Can I continue to drive my vehicle (before I receive my letter)?**
Yes. However, when you receive a letter requesting you to make an appointment to have this Safety Recall performed by an authorized BMW center, please do so as soon as possible. If you are not the only driver of this vehicle, please advise all other drivers of this important information.
- Q7. How will my vehicle be repaired?**
The front seat safety belt buckles will be inspected and, if necessary, replaced for free and can take approximately one hour.
- Q8. Is BMW Group aware of any accidents or injuries in the US, involving these BMW Group vehicles associated with this Safety Recall?**
No.
- Q9. How will I be informed of this Safety Recall?**
You will receive a letter in May via First Class mail advising you of this Safety Recall and to schedule an appointment with an authorized BMW center to have this Safety Recall performed. You can locate your nearest authorized BMW center at www.bmwusa.com/dealer. To ensure the BMW Group has your most recent contact and vehicle information, please register your BMW vehicle at www.bmwusa.com/myBMW. Registration is free, and will give you access to factory initiated campaigns and other information specific to your vehicle.
- Q10. Do I have to wait for my letter to have my vehicle serviced?**
Yes. BMW is in the process of ensuring that the necessary tools, parts, and procedures are available prior to contacting you to schedule an appointment with your authorized BMW center to have this important Safety Recall performed. For the latest updates to this Safety Recall, please visit www.bmwusa.com/recall.

BMW Group - AIR: 2020-03-13 / 15:25

Dealer: -/-

Model: X3 XDRIV A

Development code: G01

Model code: TY63

Lead type: TY63

Replacing the lower strap, left front (after vehicle diagnosis) »

Preliminary work

Remove front seat

Further information is available.

WARNING

Pyrotechnic components.

Danger! Immobilization period-threatening injuries!

- All work on pyrotechnic parts may be carried out by technically experienced and appropriately trained personnel only.
- Replace any damaged part or ones that have been dropped.
- For additional information see: 72 00 Safety regulations on handling components with gas generators.

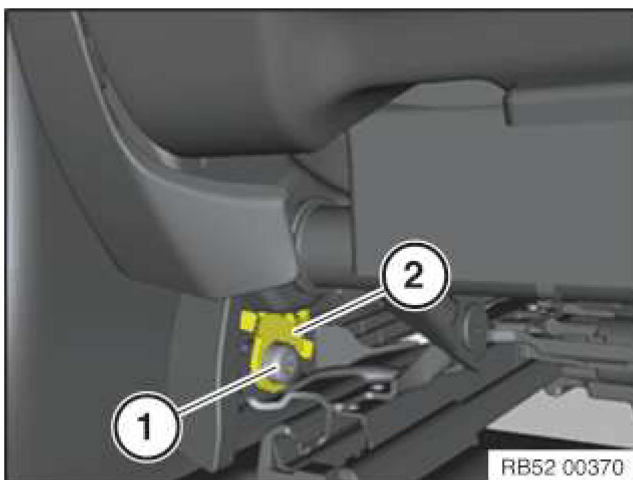

- Adjust the front seat completely to the front and top.
- Loosen screw (1).
- Remove end lining (2).

- Loosen screws (1).

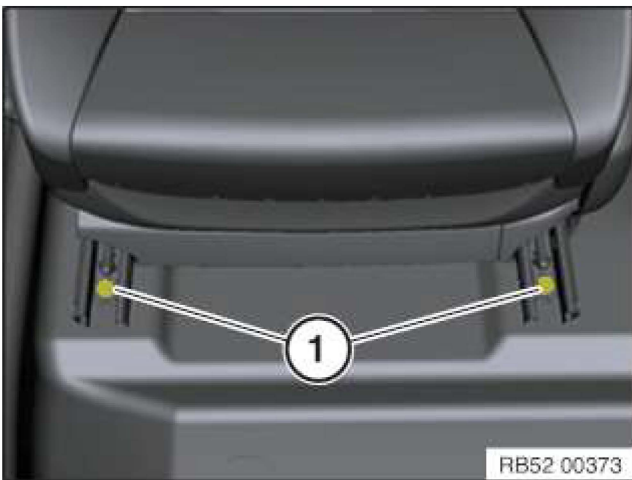
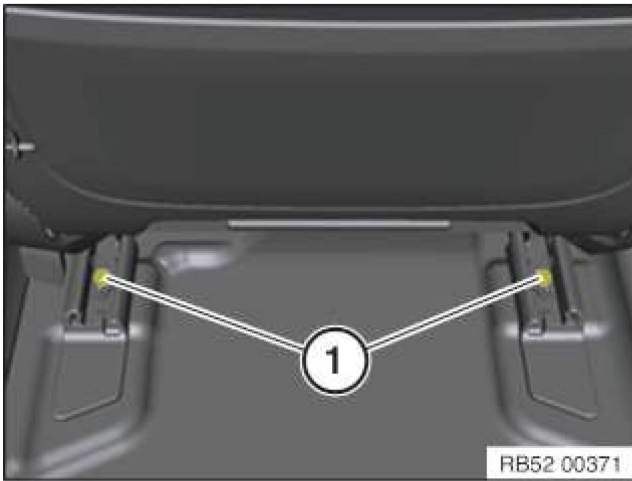

- Loosen screws (1).
- Adjust the front seat to the center position.
- When removing the driver's seat:
Retract the steering column completely.
Completely adjust the steering column upward.

► Disconnecting all battery ground leads

Further information is available.



- See additional information.



RISK OF DAMAGE

Scratches.

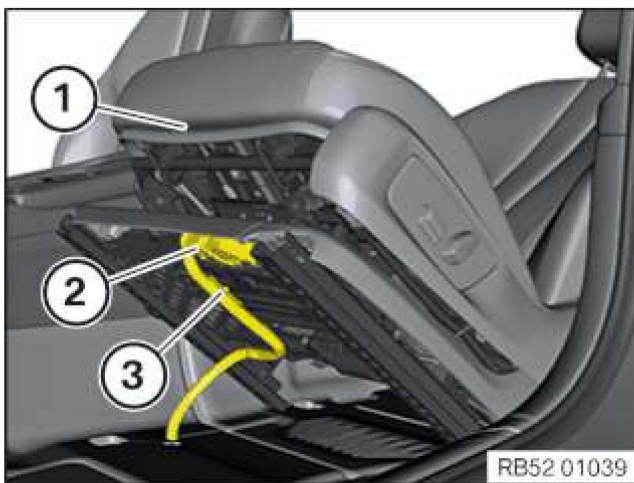

Tools and sharp-edged components can cause scratches.

- Protect working area.
- Handle tools and components carefully.

- Cover the door sill using protective covers.
- Place front seat (1) to the rear.
- Unlock plug connection (2) and disconnect.
- Loosen the cable clip (3).



RISK OF DAMAGE

Heavy component.

Heavy components can lead to injury or damage.

- Remove and install heavy components with the aid of another person/other persons.
- Lift out front seat (1) with the assistance of a second person.

Main Works

Removing front lower strap

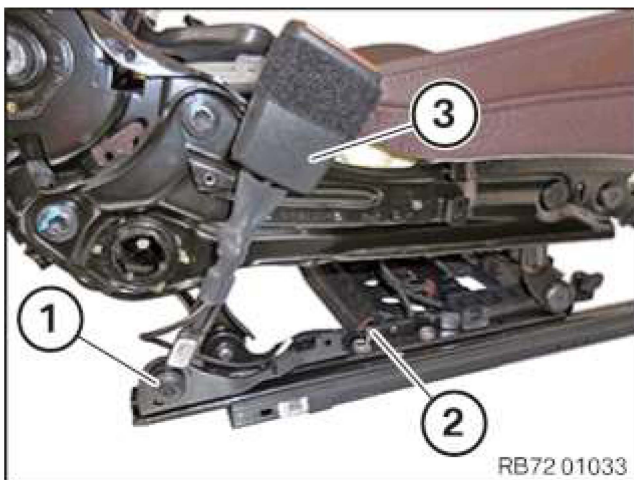

- Loosen screw (1).
- Disconnect the connector (2) and unclip the present cable holder.
- Pull out the lower belt (3) and remove.

Installing the front lower strap

- Insert and position the lower strap (3).
- Renew the screw (1).

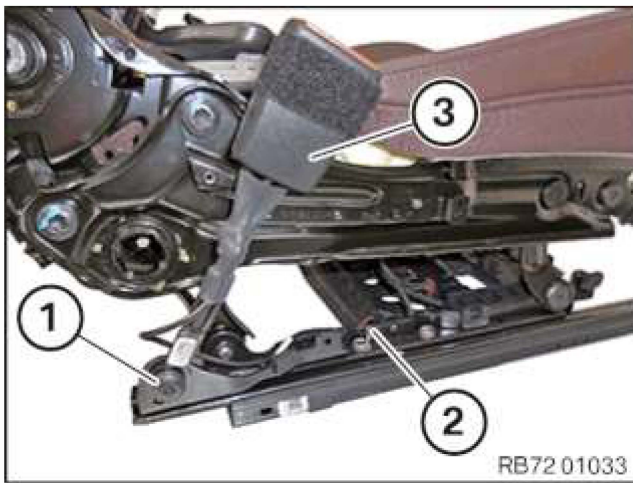

Parts: screw

- Tighten down screw (1).

Tightening torques

Lower strap to seat mechanism

M10 screw
Renew screw.

42Nm

- Connect the plug connection (2) and clip in any existing cable clips.

Follow-up works

Install front seat

Further information is available.

⚠ WARNING

Pyrotechnic components.

Danger! Immobilization period-threatening injuries!

- All work on pyrotechnic parts may be carried out by technically experienced and appropriately trained personnel only.
- Replace any damaged part or ones that have been dropped.
- For additional information see: 72 00 Safety regulations on handling components with gas generators.

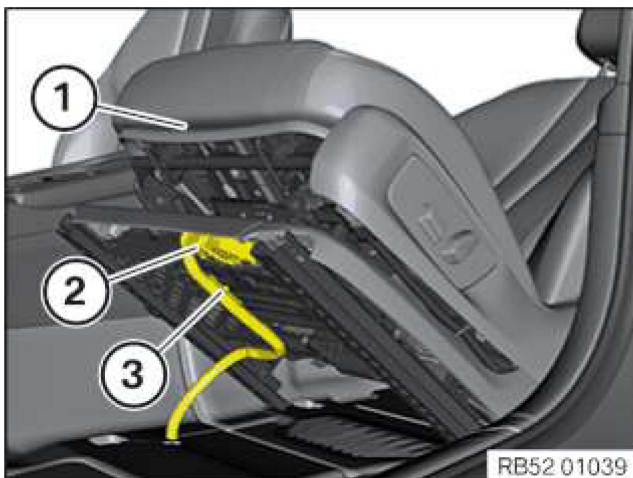

RISK OF DAMAGE

Scratches.

Tools and sharp-edged components can cause scratches.

- Protect working area.
 - Handle tools and components carefully.
- Cover the door sill using protective covers.



RISK OF DAMAGE

Heavy component.

Heavy components can lead to injury or damage.

- Remove and install heavy components with the aid of another person/other persons.

- Lift front seat (1) into the vehicle with the assistance of a second person.
- Place front seat (1) to the rear.
- Connect plug (2).
- Attach the cable clip (3).

► Disconnecting all battery ground leads

Further information is available.



- See additional information.

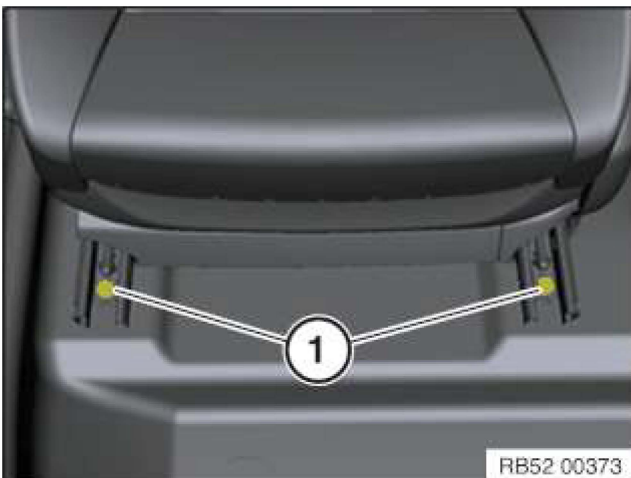

- Adjust the front seat to the rear.
- Renew screws (1).
Parts: screw
- Tighten down screws (1).

Tightening torques

Seat to body

M10
Renew screw.

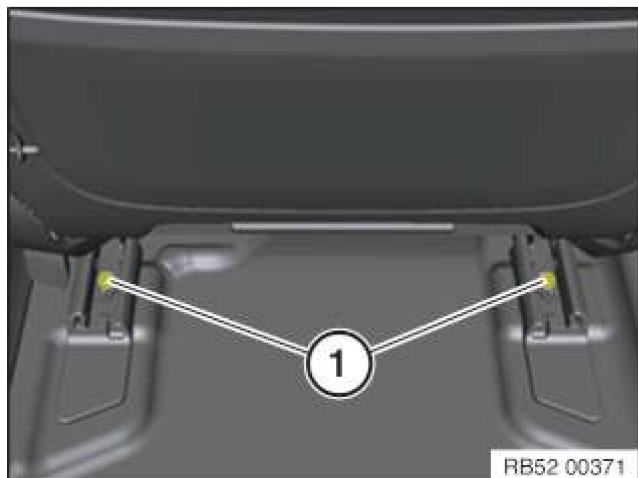

tightening torque 42Nm

- Shift front seat forwards.
 - Renew screws (1).
- Parts: screw
- Tighten down screws (1).

Tightening torques

Seat to body

M10
Renew screw.

tightening torque 42Nm

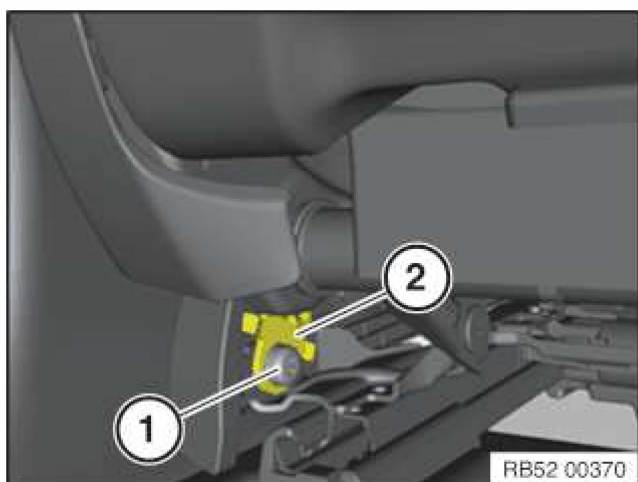

- Fully adjust the front seat to the front and top.
 - Insert the end fitting (2).
 - Renew the screw (1).
- Parts: Screw
- Tighten down screw (1).

Tightening torques

Seat belt strap fitting to seat mechanism

M10
Renew screw.

tightening torque 42Nm

BMW Group - AIR: 2020-03-13 / 15:26

Dealer: -/-

Model: X4 M

Development code: F98

Model code: UJ03

Lead type: UJ03

Replacing the lower strap, left front (after vehicle diagnosis) »

Preliminary work

Remove front seat

Further information is available.

WARNING

Pyrotechnic components.

Danger! Immobilization period-threatening injuries!

- All work on pyrotechnic parts may be carried out by technically experienced and appropriately trained personnel only.
- Replace any damaged part or ones that have been dropped.
- For additional information see: 72 00 Safety regulations on handling components with gas generators.

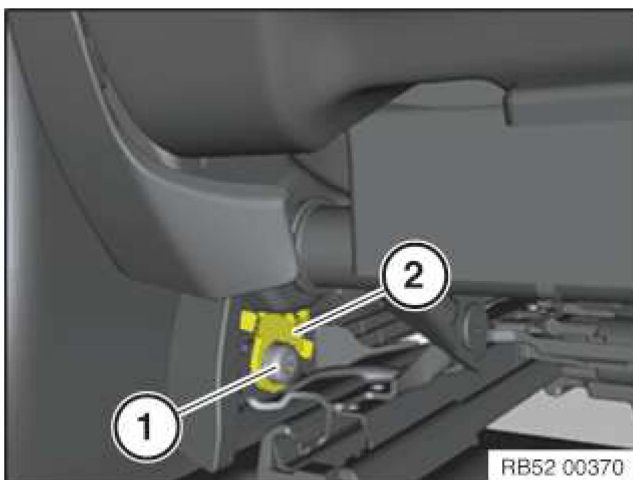

- Adjust the front seat completely to the front and top.
- Loosen screw (1).
- Remove end lining (2).

- Loosen screws (1).

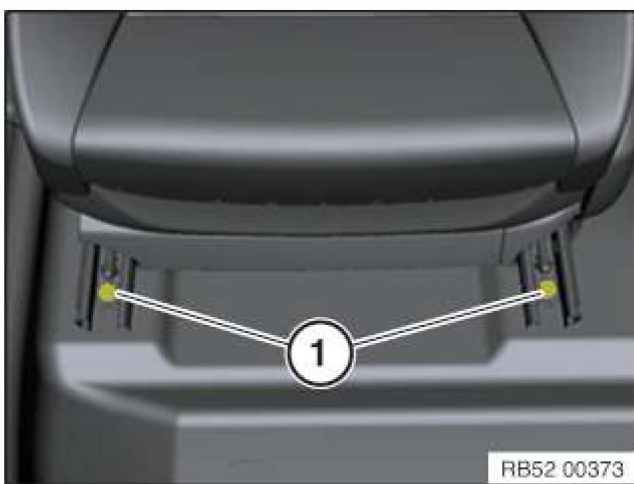
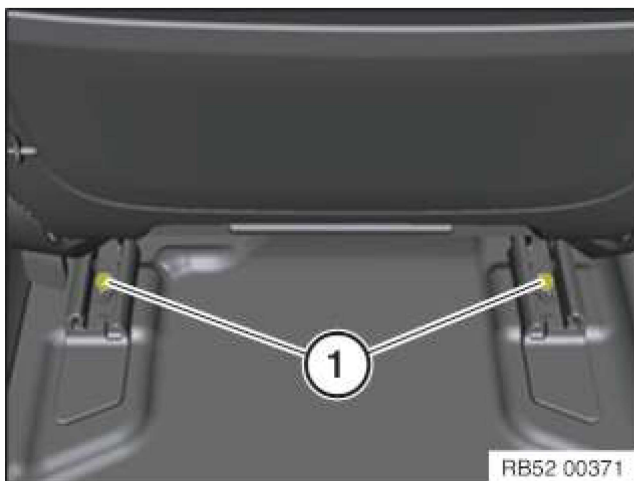

- Loosen screws (1).
- Adjust the front seat to the center position.
- When removing the driver's seat:
Retract the steering column completely.
Completely adjust the steering column upward.

► Disconnecting all battery ground leads

Further information is available.



- See additional information.



RISK OF DAMAGE

Scratches.

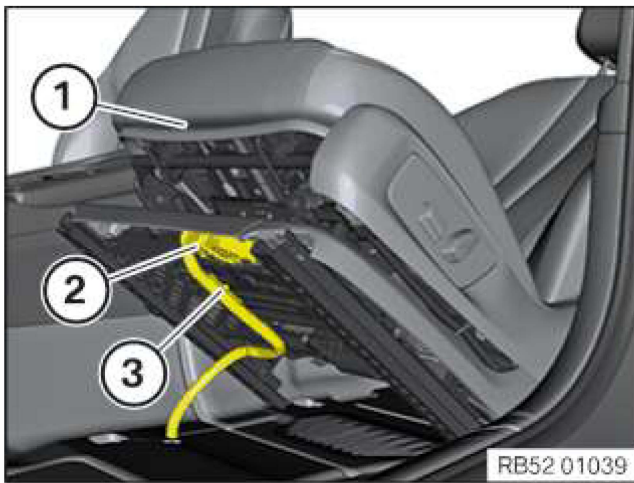

Tools and sharp-edged components can cause scratches.

- Protect working area.
- Handle tools and components carefully.

- Cover the door sill using protective covers.
- Place front seat (1) to the rear.
- Unlock plug connection (2) and disconnect.
- Loosen the cable clip (3).



RISK OF DAMAGE

Heavy component.

Heavy components can lead to injury or damage.

- Remove and install heavy components with the aid of another person/other persons.
- Lift out front seat (1) with the assistance of a second person.

Main Works

Removing front lower strap

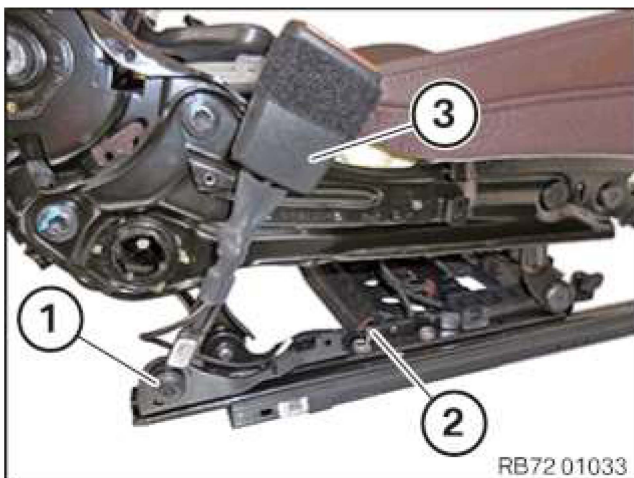

- Loosen screw (1).
- Disconnect the connector (2) and unclip the present cable holder.
- Pull out the lower belt (3) and remove.

Installing the front lower strap

- Insert and position the lower strap (3).
- Renew the screw (1).

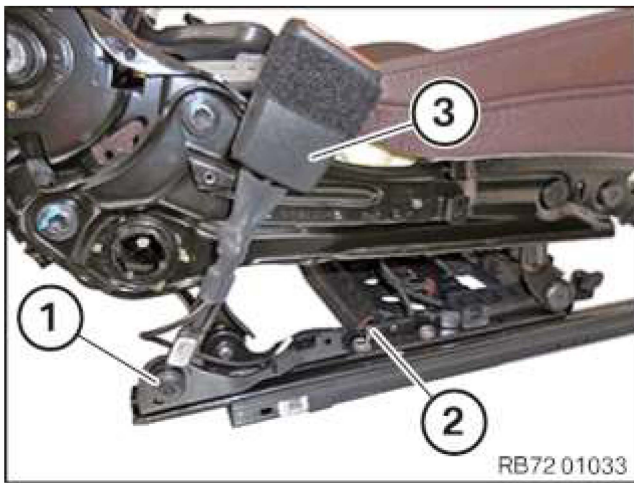

Parts: screw

- Tighten down screw (1).

Tightening torques

Lower strap to seat mechanism

M10 screw
Renew screw.

42Nm

- Connect the plug connection (2) and clip in any existing cable clips.

Follow-up works

Install front seat

Further information is available.

⚠ WARNING

Pyrotechnic components.

Danger! Immobilization period-threatening injuries!

- All work on pyrotechnic parts may be carried out by technically experienced and appropriately trained personnel only.
- Replace any damaged part or ones that have been dropped.
- For additional information see: 72 00 Safety regulations on handling components with gas generators.

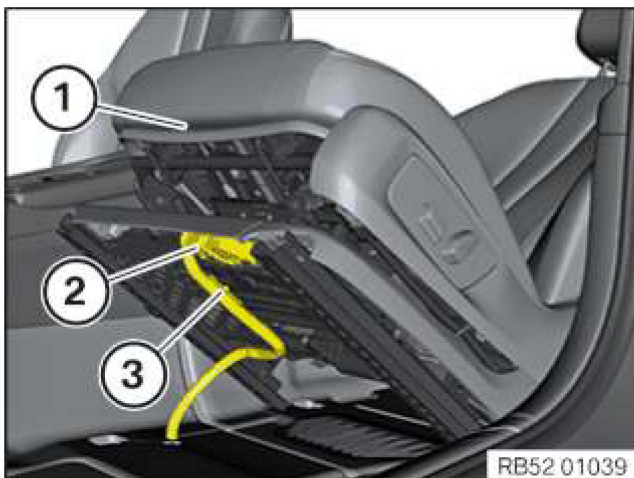

RISK OF DAMAGE

Scratches.

Tools and sharp-edged components can cause scratches.

- Protect working area.
 - Handle tools and components carefully.
- Cover the door sill using protective covers.



RISK OF DAMAGE

Heavy component.

Heavy components can lead to injury or damage.

- Remove and install heavy components with the aid of another person/other persons.

- Lift front seat (1) into the vehicle with the assistance of a second person.
- Place front seat (1) to the rear.
- Connect plug (2).
- Attach the cable clip (3).

► Disconnecting all battery ground leads

Further information is available.



- See additional information.

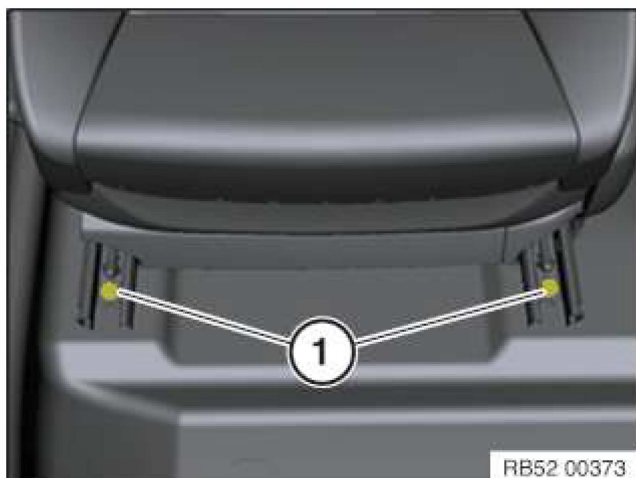

- Adjust the front seat to the rear.
- Renew screws (1).
Parts: screw
- Tighten down screws (1).

Tightening torques

Seat to body

M10
Renew screw.

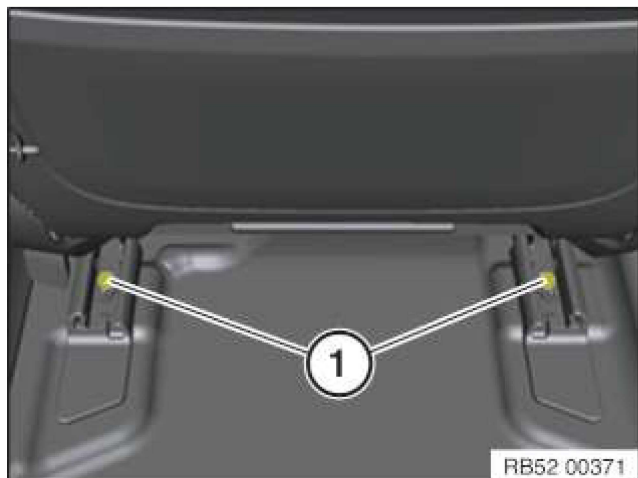

tightening torque
42Nm

- Shift front seat forwards.
 - Renew screws (1).
- Parts: screw
- Tighten down screws (1).

Tightening torques

Seat to body

M10
Renew screw.

tightening torque
42Nm

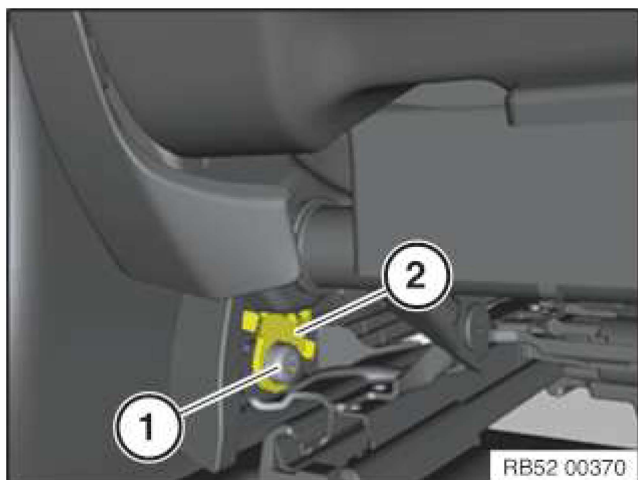

- Fully adjust the front seat to the front and top.
 - Insert the end fitting (2).
 - Renew the screw (1).
- Parts: Screw
- Tighten down screw (1).

Tightening torques

Seat belt strap fitting to seat mechanism

M10
Renew screw.

tightening torque
42Nm

BMW Group - AIR: 2020-03-13 / 15:03

Dealer: -/-

Model: M8

Vehicle identification number: WBSDZ0C04LCE36819

Development code: F91

Model code: DZ03

Lead type: DZ03

Replacing the lower strap, left front (after vehicle diagnosis) »

Preliminary work

Remove driver's seat.

Further information is available.

WARNING

Pyrotechnic components.

Danger! Immobilization period-threatening injuries!

- All work on pyrotechnic parts may be carried out by technically experienced and appropriately trained personnel only.
- Replace any damaged part or ones that have been dropped.
- For additional information see: 72 00 Safety regulations on handling components with gas generators.

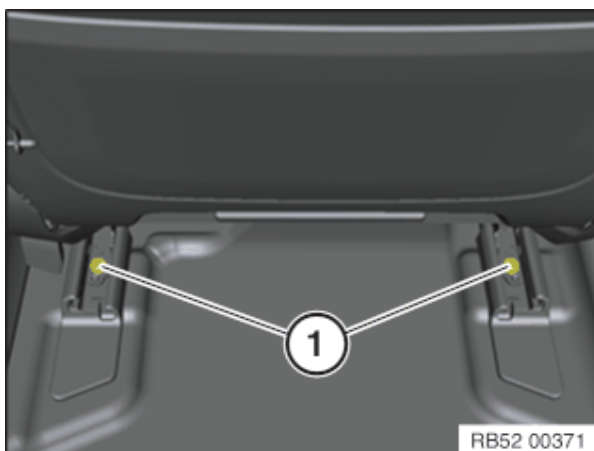

- Shift front seat forwards.
- Loosen screws (1).

- Shift front seat rearwards.
- Loosen screws (1).

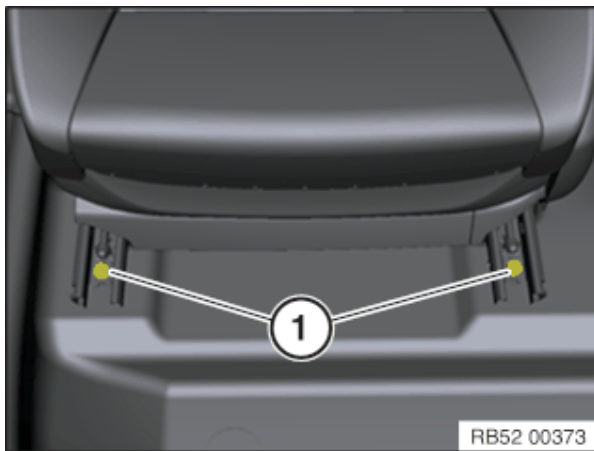

- Adjust the front seat to the center position.
- **When removing the driver's seat:**
Move the steering column to the fully retracted position and shift upwards fully.

► Disconnecting all battery ground leads

Further information is available.



- See additional information.

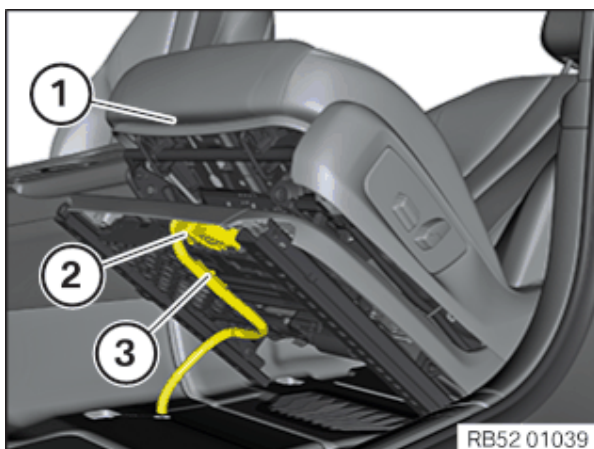

 **RISK OF DAMAGE**

Scratches.
Tools and sharp-edged components can cause scratches.

- Protect working area.
- Handle tools and components carefully.

- Cover the door sill using protective covers.
- Place front seat (1) to the rear.
- Unlock plug connection (2) and disconnect.

- Loosen the cable clip (3).



RISK OF DAMAGE

Heavy component.

Heavy components can lead to injury or damage.

- Remove and install heavy components with the aid of another person/other persons.

- Lift out front seat (1) with the assistance of a second person.

Main Works

Removing front lower strap

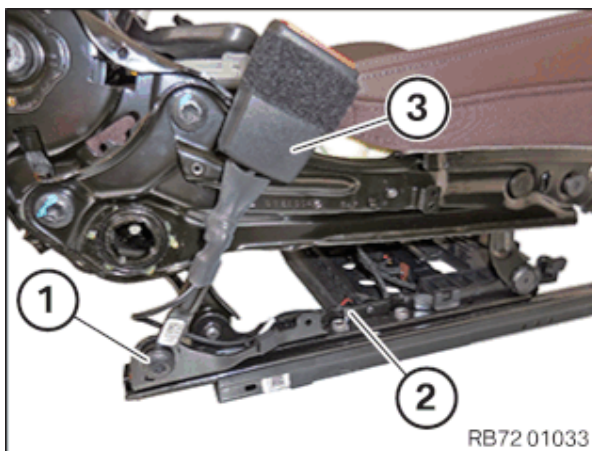

- Loosen screw (1).
- Disconnect the connector (2) and unclip the present cable holder.
- Pull out the lower belt (3) and remove.

Installing the front lower strap

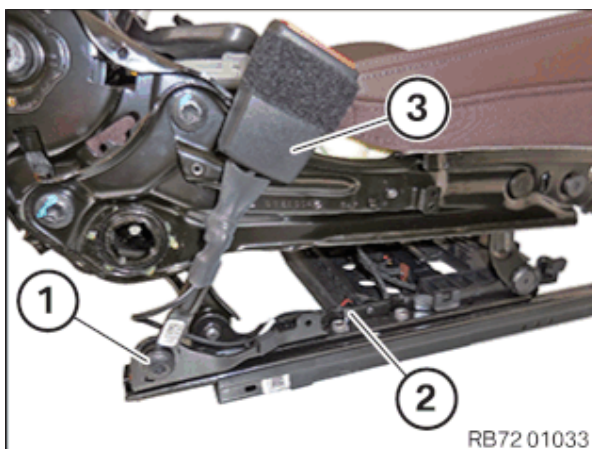

- Insert and position the lower strap (3).
 - Renew the screw (1).
- Parts:** screw
- Tighten down screw (1).

Tightening torques

Lower strap to seat mechanism

M10 screw
Renew screw.

42Nm

- Connect the plug connection (2) and clip in any existing cable clips.

Follow-up works

Install driver's seat

Further information is available.

WARNING

Pyrotechnic components.

Danger! Immobilization period-threatening injuries!

- All work on pyrotechnic parts may be carried out by technically experienced and appropriately trained personnel only.
- Replace any damaged part or ones that have been dropped.
- For additional information see: 72 00 Safety regulations on handling components with gas generators.

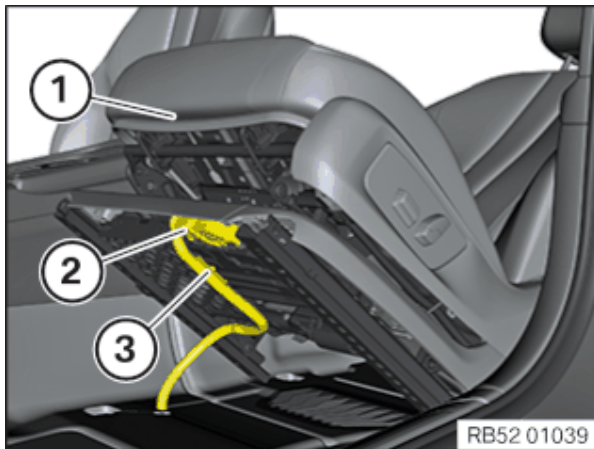

RISK OF DAMAGE

Scratches.

Tools and sharp-edged components can cause scratches.

- Protect working area.
- Handle tools and components carefully.

- Cover the door sill using protective covers.

RISK OF DAMAGE

Heavy component.

Heavy components can lead to injury or damage.

- Remove and install heavy components with the aid of another person/other persons.

- Lift front seat (1) into the vehicle with the assistance of a second person.

- Place front seat (1) to the rear.
- Connect connectors (2) and lock.
- *Check all plug connections for completeness, correct fit and locking where required.*
- Attach the cable clip (3).

► Disconnecting all battery ground leads

Further information is available.



- See additional information.

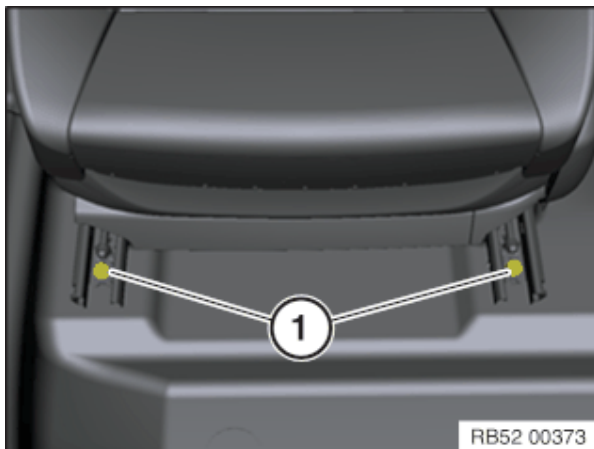

- Shift front seat rearwards.
 - Renew screws (1).
- Parts:** Screws
- Tighten down screws (1).

Tightening torques

Seat to body

M10
Renew screw.

tightening torque
42Nm

- Shift front seat forwards.
 - Renew screws (1).
- Parts:** Screws

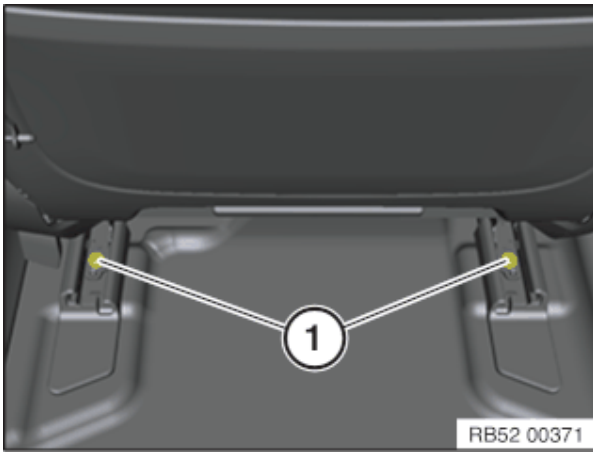

- Tighten down screws (1).

Tightening torques

Seat to body

M10

Renew screw.

tightening torque
42Nm



BMW Group - AIR: 2020-03-13 / 15:17

Dealer: -/-

Model: M8

Development code: F92

Model code: AE03

Lead type: AE03

Replacing the lower strap, left front (after vehicle diagnosis) »

Preliminary work

Remove driver's seat.

Further information is available.

WARNING

Pyrotechnic components.

Danger! Immobilization period-threatening injuries!

- All work on pyrotechnic parts may be carried out by technically experienced and appropriately trained personnel only.
- Replace any damaged part or ones that have been dropped.
- For additional information see: 72 00 Safety regulations on handling components with gas generators.

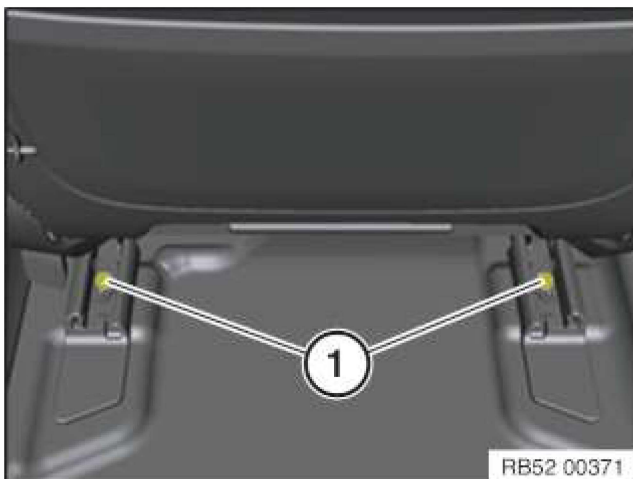

- Shift front seat forwards.
- Loosen screws (1).

- Shift front seat rearwards.
- Loosen screws (1).
- Adjust the front seat to the center position.

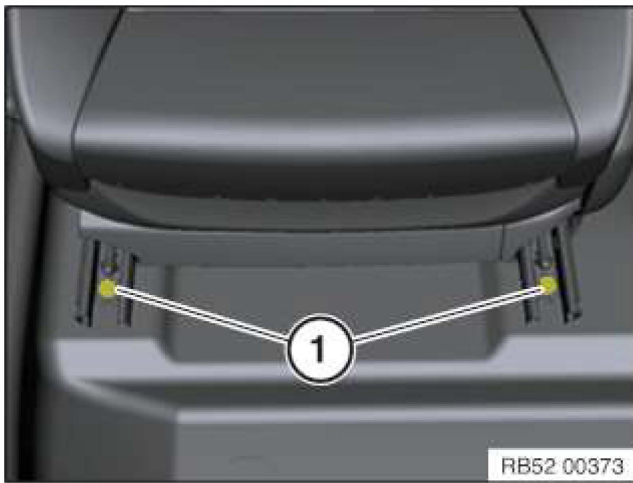

- When removing the driver's seat:

Move the steering column to the fully retracted position and shift upwards fully.

► Disconnecting all battery ground leads

Further information is available.



- See additional information.

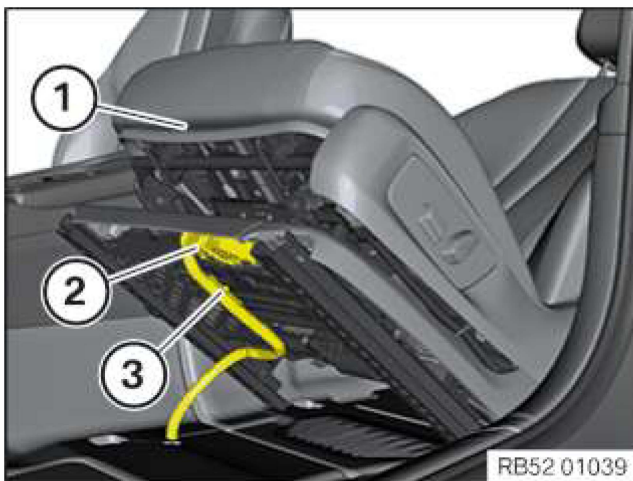

RISK OF DAMAGE

Scratches.

Tools and sharp-edged components can cause scratches.

- Protect working area.
- Handle tools and components carefully.

- Cover the door sill using protective covers.
- Place front seat (1) to the rear.
- Unlock plug connection (2) and disconnect.
- Loosen the cable clip (3).



RISK OF DAMAGE

Heavy component.

Heavy components can lead to injury or damage.

- Remove and install heavy components with the aid of another person/other persons.

- Lift out front seat (1) with the assistance of a second person.

Main Works

Removing front lower strap

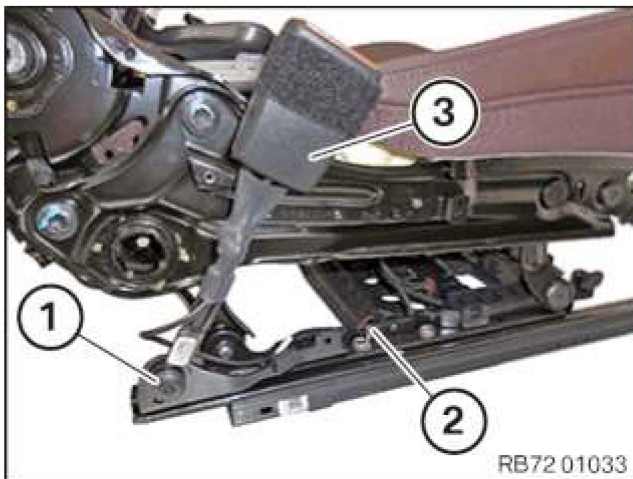

- Loosen screw (1).
- Disconnect the connector (2) and unclip the present cable holder.
- Pull out the lower belt (3) and remove.

Installing the front lower strap

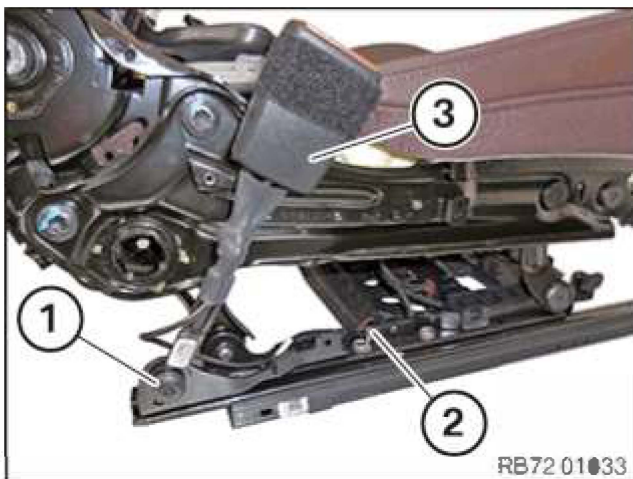

- Insert and position the lower strap (3).
 - Renew the screw (1).
- Parts: screw
- Tighten down screw (1).

Tightening torques

Lower strap to seat mechanism

M10 screw
Renew screw.

42Nm

- Connect the plug connection (2) and clip in any existing cable clips.

Follow-up works

Install driver's seat

Further information is available.

⚠ WARNING

Pyrotechnic components.

Danger! Immobilization period-threatening injuries!

- All work on pyrotechnic parts may be carried out by technically experienced and appropriately trained personnel only.
- Replace any damaged part or ones that have been dropped.
- For additional information see: 72 00 Safety regulations on handling components with gas generators.

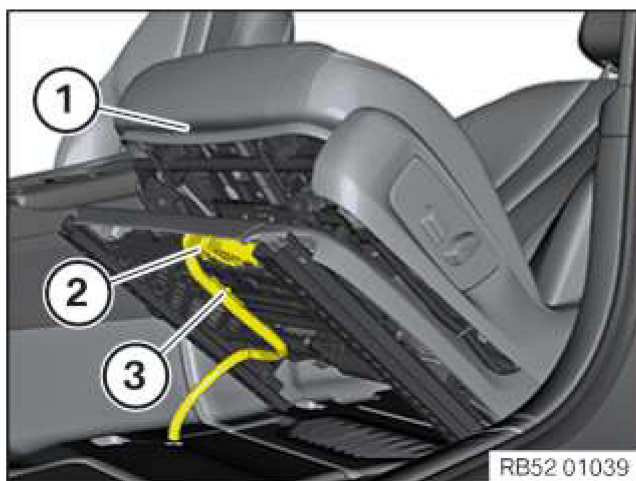

🔧 RISK OF DAMAGE

Scratches.

Tools and sharp-edged components can cause scratches.

- Protect working area.
- Handle tools and components carefully.

- Cover the door sill using protective covers.

🔧 RISK OF DAMAGE

Heavy component.

Heavy components can lead to injury or damage.

- Remove and install heavy components with the aid of another person/other persons.

- Lift front seat (1) into the vehicle with the assistance of a second person.
- Place front seat (1) to the rear.
- Connect connectors (2) and lock.

- Check all plug connections for completeness, correct fit and locking where required.
- Attach the cable clip (3).

► Disconnecting all battery ground leads

Further information is available.



- See additional information.

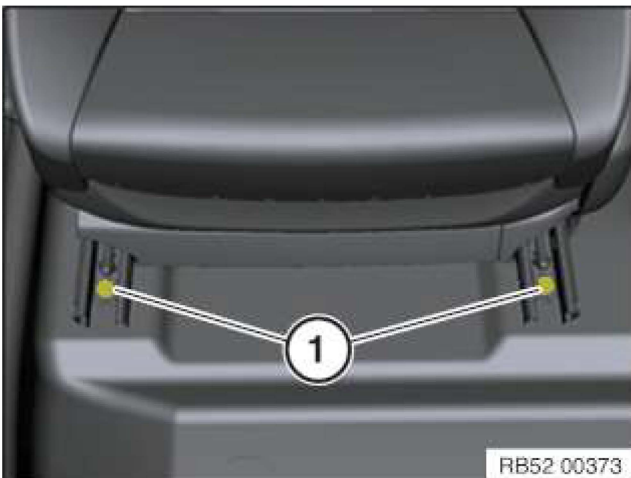

- Shift front seat rearwards.
 - Renew screws (1).
- Parts: Screws
- Tighten down screws (1).

Tightening torques

Seat to body

M10
Renew screw.

tightening torque
42Nm

- Shift front seat forwards.
 - Renew screws (1).
- Parts: Screws
- Tighten down screws (1).

Tightening torques

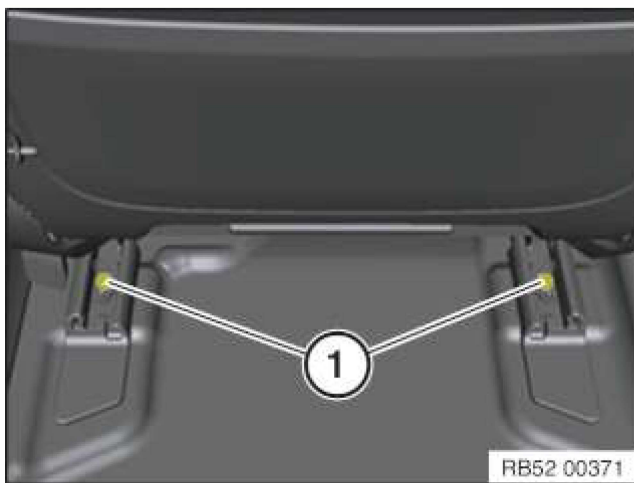

Seat to body

M10
Renew screw.

tightening torque
42Nm



BMW Group - AIR: 2020-03-13 / 15:24

Dealer: -/-

Model: 840i

Development code: G16

Model code: GV23

Lead type: GV23

Replacing the lower strap, left front (after vehicle diagnosis) »

Preliminary work

Remove driver's seat.

Further information is available.

WARNING

Pyrotechnic components.

Danger! Immobilization period-threatening injuries!

- All work on pyrotechnic parts may be carried out by technically experienced and appropriately trained personnel only.
- Replace any damaged part or ones that have been dropped.
- For additional information see: 72 00 Safety regulations on handling components with gas generators.

► Removing the strap fitting

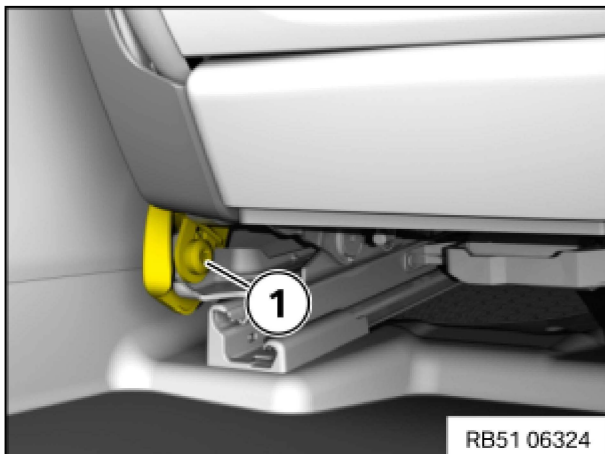

- Adjust the front seat completely to the front and top.
- Loosen screw (1).
- Remove end lining (2).



- Shift front seat forwards.

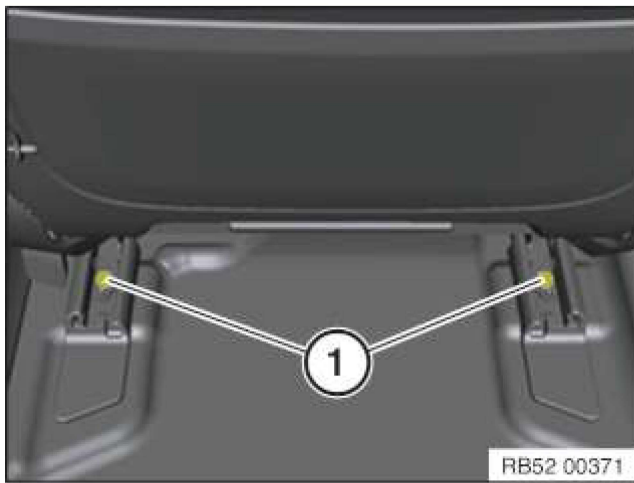

- Loosen screws (1).

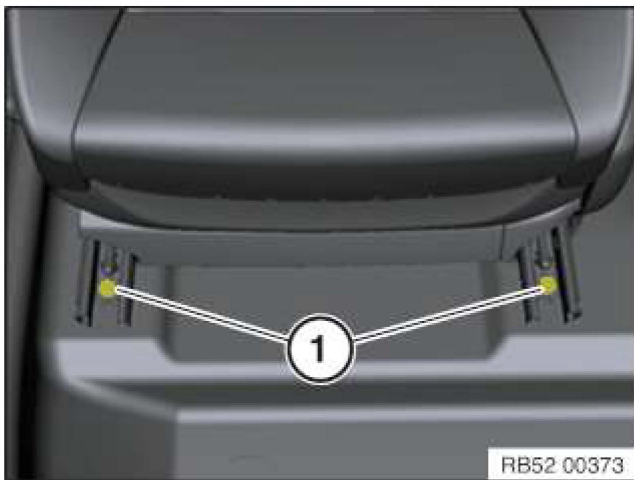

- Shift front seat rearwards.
- Loosen screws (1).
- Adjust the front seat to the center position.
- When removing the driver's seat:
Move the steering column to the fully retracted position and shift upwards fully.

Further information is available.

► Disconnecting all battery ground leads



- See additional information.



RISK OF DAMAGE

Scratches.

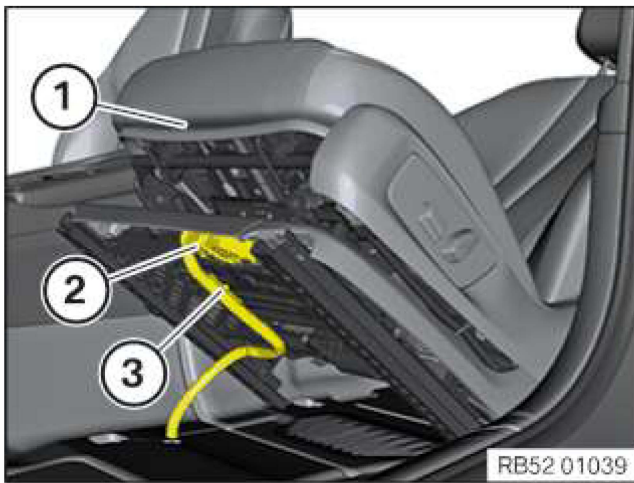

Tools and sharp-edged components can cause scratches.

- Protect working area.
- Handle tools and components carefully.

- Cover the door sill using protective covers.
- Place front seat (1) to the rear.
- Unlock plug connection (2) and disconnect.
- Loosen the cable clip (3).



RISK OF DAMAGE

Heavy component.

Heavy components can lead to injury or damage.

- Remove and install heavy components with the aid of another person/other persons.
- Lift out front seat (1) with the assistance of a second person.

Main Works

Removing front lower strap

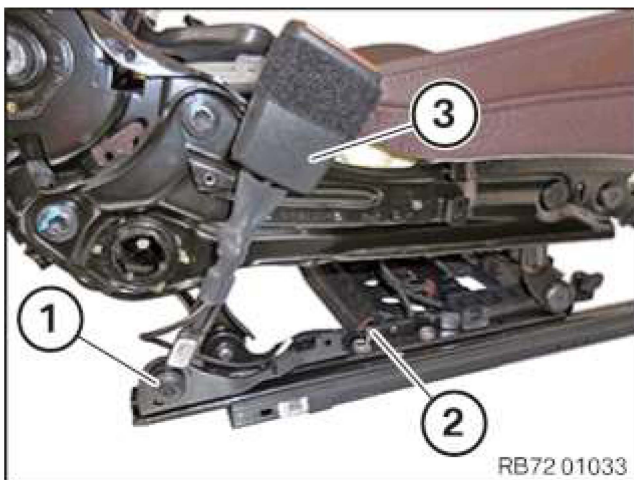

- Loosen screw (1).
- Disconnect the connector (2) and unclip the present cable holder.
- Pull out the lower belt (3) and remove.

Installing the front lower strap

- Insert and position the lower strap (3).
- Renew the screw (1).

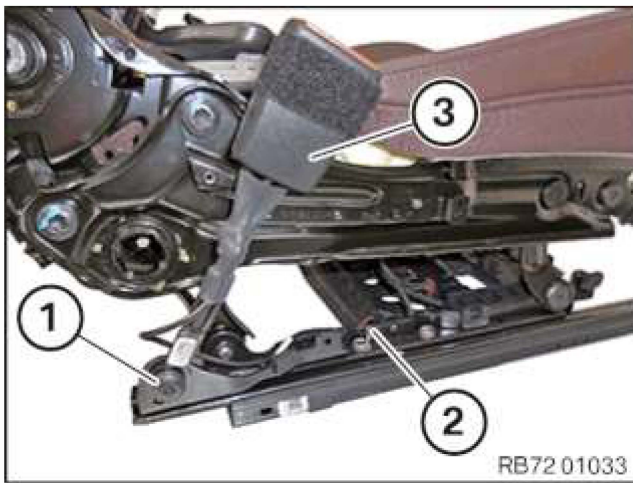

Parts: screw

- Tighten down screw (1).

Tightening torques

Lower strap to seat mechanism

M10 screw
Renew screw.

42Nm

- Connect the plug connection (2) and clip in any existing cable clips.

Follow-up works

Install driver's seat

Further information is available.

⚠ WARNING

Pyrotechnic components.

Danger! Immobilization period-threatening injuries!

- All work on pyrotechnic parts may be carried out by technically experienced and appropriately trained personnel only.
- Replace any damaged part or ones that have been dropped.
- For additional information see: 72 00 Safety regulations on handling components with gas generators.

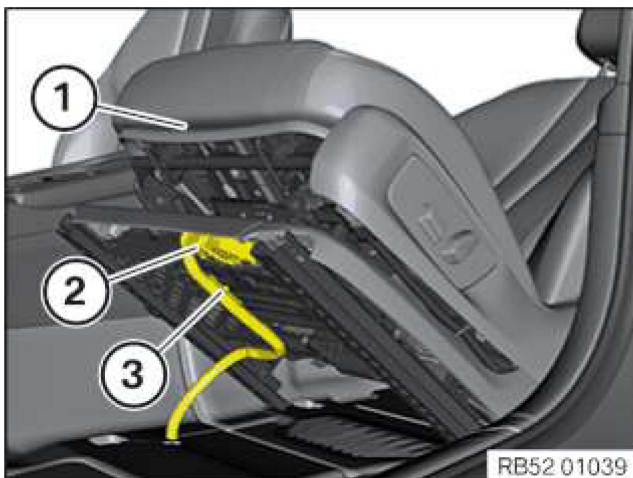

RISK OF DAMAGE

Scratches.

Tools and sharp-edged components can cause scratches.

- Protect working area.
 - Handle tools and components carefully.
- Cover the door sill using protective covers.



RISK OF DAMAGE

Heavy component.

Heavy components can lead to injury or damage.

- Remove and install heavy components with the aid of another person/other persons.

- Lift front seat (1) into the vehicle with the assistance of a second person.
- Place front seat (1) to the rear.
- Connect connectors (2) and lock.
- *Check all plug connections for completeness, correct fit and locking where required.*
- Attach the cable clip (3).

► Disconnecting all battery ground leads

Further information is available.



- See additional information.



- Shift front seat rearwards.
 - Renew screws (1).
- Parts: Screws
- Tighten down screws (1).

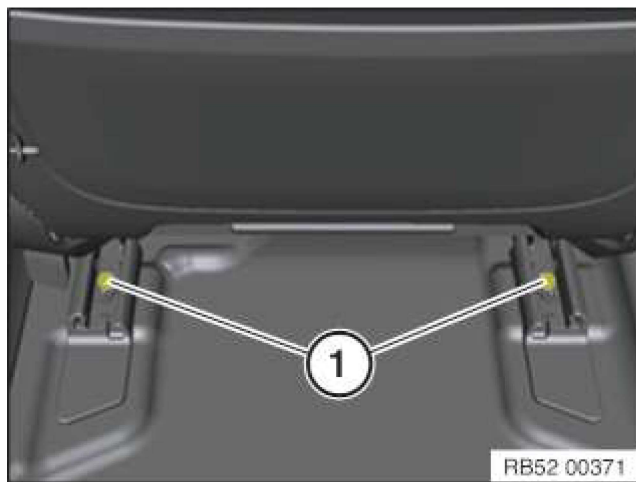
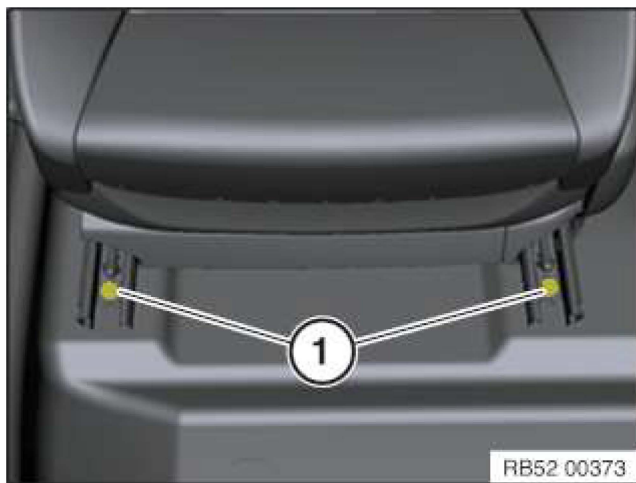

- Shift front seat forwards.
 - Renew screws (1).
- Parts: Screws
- Tighten down screws (1).

► Installing the strap fitting

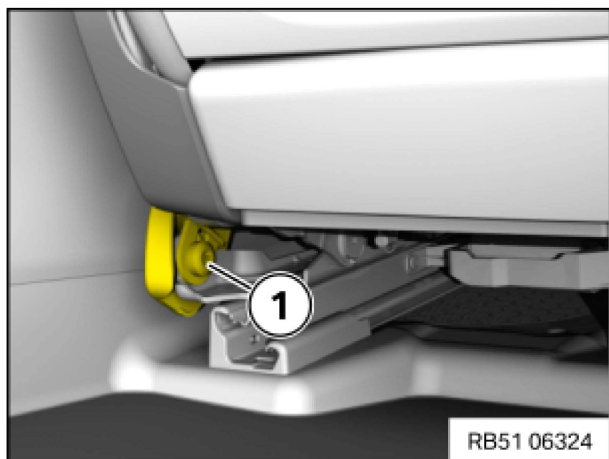

- Adjust the front seat completely to the front and top.
 - Insert the end fitting (2).
 - Renew the screw (1).
- Parts: Screw
- Tighten down screw (1).

Tightening torques

Seat belt strap fitting to seat mechanism

Flat-head
screw M10
Renew screw.

Tightening torque
42Nm



BMW Group - AIR: 2020-03-13 / 14:59

Dealer: -/-

Model: 330i A

Vehicle identification number: 3MW5R1J00L8B27757

Development code: G20

Model code: 5R29

Lead type: 5R23

Replacing the lower strap, left front (after vehicle diagnosis) »

Preliminary work

Remove front seat

Further information is available.

WARNING

Pyrotechnic components.

Danger! Immobilization period-threatening injuries!

- All work on pyrotechnic parts may be carried out by technically experienced and appropriately trained personnel only.
- Replace any damaged part or ones that have been dropped.
- For additional information see: 72 00 Safety regulations on handling components with gas generators.

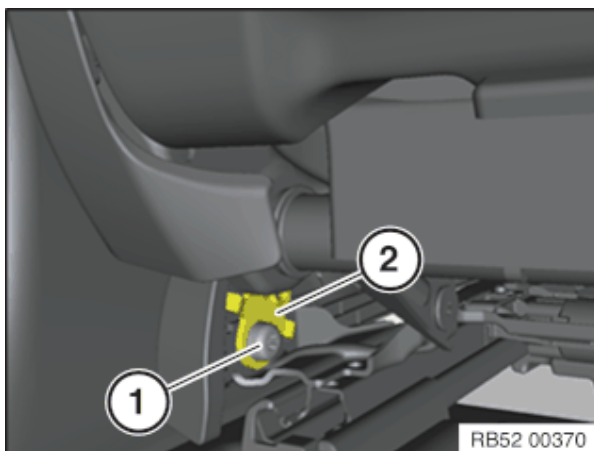

- Adjust the front seat completely to the front and top.
- Loosen screw (1).
- Remove end lining (2).

- Loosen screws (1).

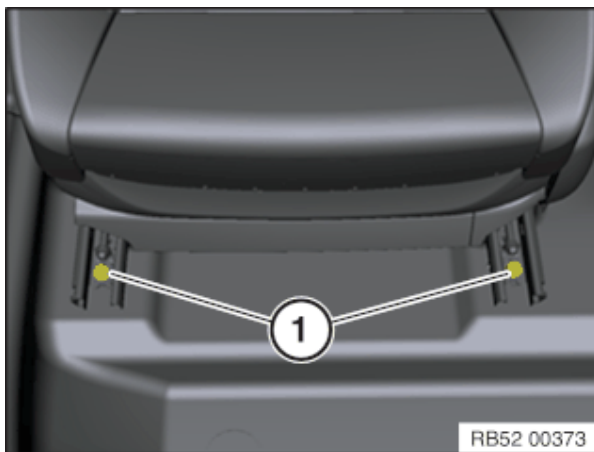
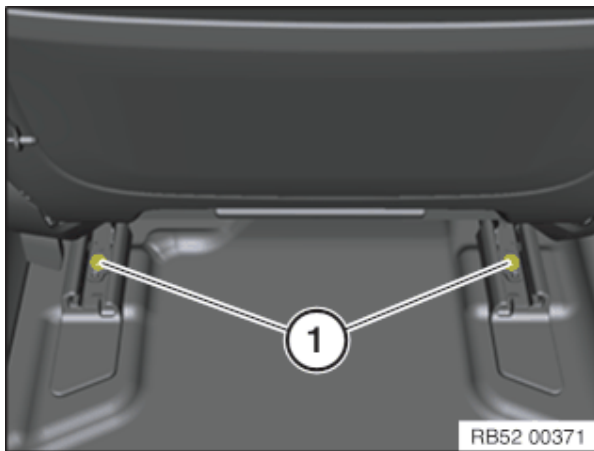

- Loosen screws (1).
- Adjust the front seat to the center position.
- **When removing the driver's seat:**
Retract the steering column completely.
Completely adjust the steering column upward.

► Disconnecting all battery ground leads

Further information is available.



- See additional information.



RISK OF DAMAGE

Scratches.

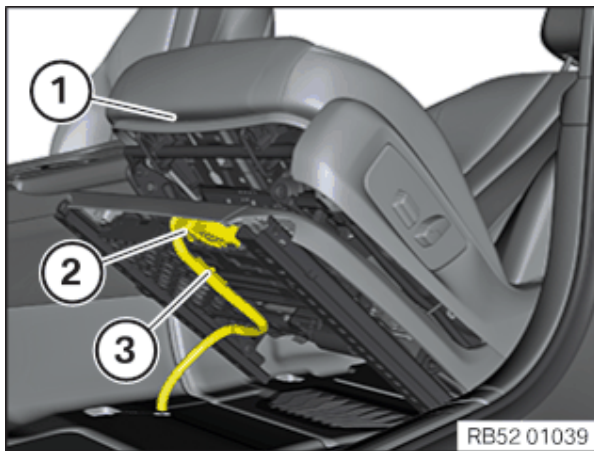

Tools and sharp-edged components can cause scratches.

- Protect working area.
- Handle tools and components carefully.

- Cover the door sill using protective covers.
- Place front seat (1) to the rear.
- Unlock plug connection (2) and disconnect.
- Loosen the cable clip (3).



RISK OF DAMAGE

Heavy component.

Heavy components can lead to injury or damage.

- Remove and install heavy components with the aid of another person/other persons.

- Lift out front seat (1) with the assistance of a second person.

Main Works

Removing front lower strap

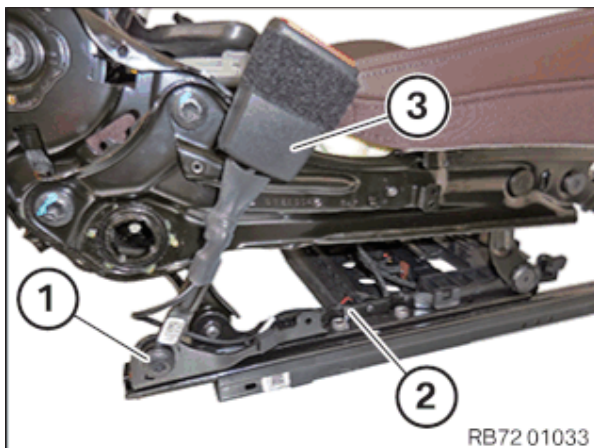

- Loosen screw (1).
- Disconnect the connector (2) and unclip the present cable holder.
- Pull out the lower belt (3) and remove.

Installing the front lower strap

- Insert and position the lower strap (3).
- Renew the screw (1).

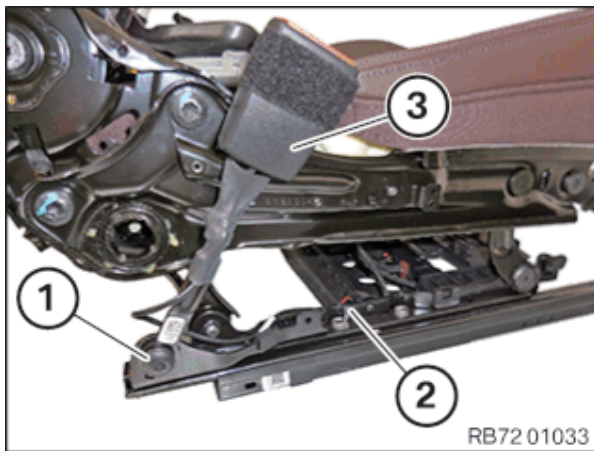

Parts: screw

- Tighten down screw (1).

Tightening torques

Lower strap to seat mechanism

M10 screw
Renew screw.

42Nm

- Connect the plug connection (2) and clip in any existing cable clips.

Follow-up works

Install front seat

Further information is available.

⚠ WARNING

Pyrotechnic components.

Danger! Immobilization period-threatening injuries!

- All work on pyrotechnic parts may be carried out by technically experienced and appropriately trained personnel only.
- Replace any damaged part or ones that have been dropped.
- For additional information see: 72 00 Safety regulations on handling components with gas generators.

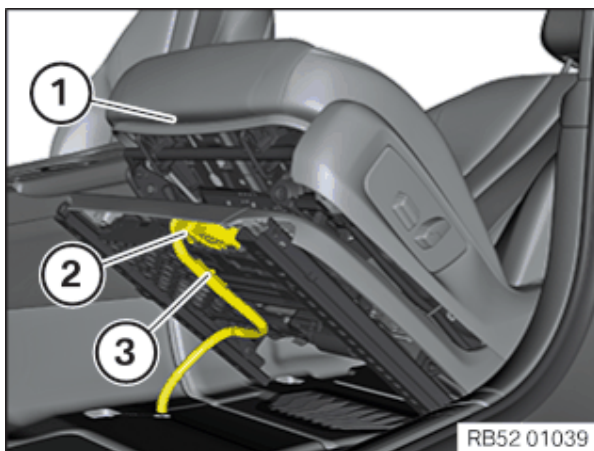

RISK OF DAMAGE

Scratches.

Tools and sharp-edged components can cause scratches.

- Protect working area.
- Handle tools and components carefully.

- Cover the door sill using protective covers.



RISK OF DAMAGE

Heavy component.

Heavy components can lead to injury or damage.

- Remove and install heavy components with the aid of another person/other persons.

- Lift front seat (1) into the vehicle with the assistance of a second person.
- Place front seat (1) to the rear.
- Connect plug (2) .
- Attach the cable clip (3).

► **Disconnecting all battery ground leads**

Further information is available.



- See additional information.



- Adjust the front seat to the rear.
 - Renew screws (1).
- Parts:** screw
- Tighten down screws (1).

Tightening torques

Seat to body

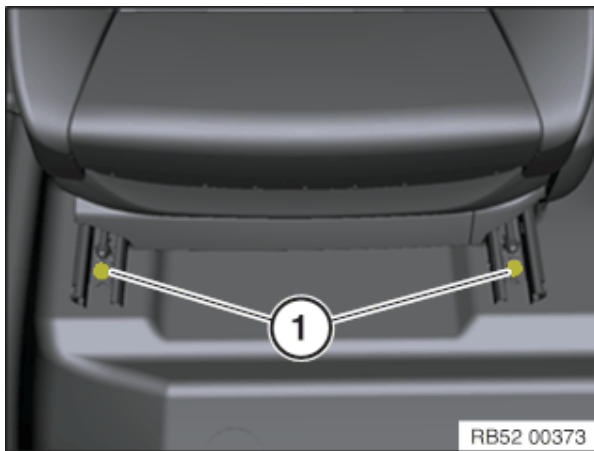

M10
Renew screw.

tightening torque
42Nm

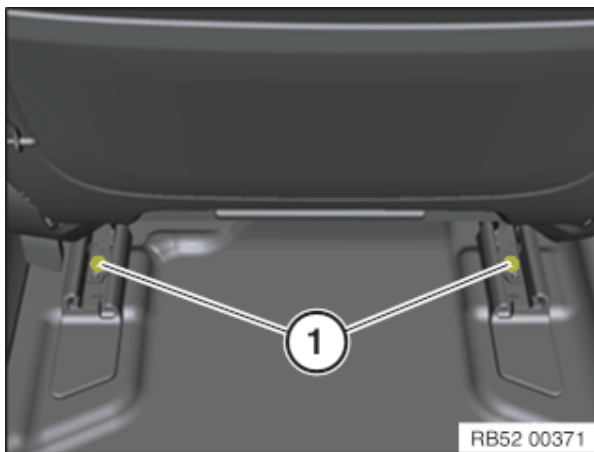

- Shift front seat forwards.
- Renew screws (1).

Parts: screw

- Tighten down screws (1).

Tightening torques

Seat to body

M10
Renew screw.

tightening torque
42Nm

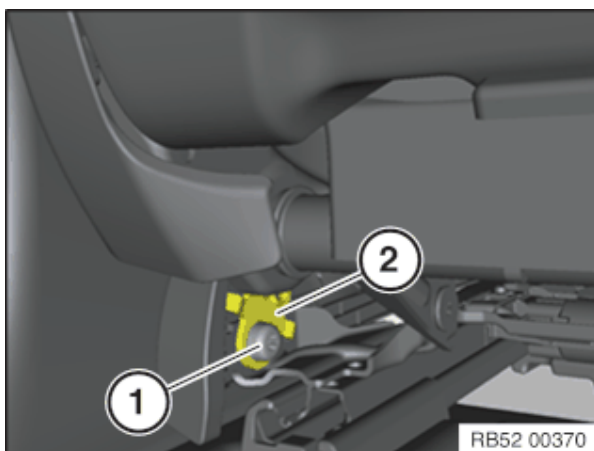

- Fully adjust the front seat to the front and top.
- Insert the end fitting (2).
- Renew the screw (1).

Parts: Screw

- Tighten down screw (1).

Tightening torques

Seat belt strap fitting to seat mechanism

M10
Renew screw.

tightening torque
42Nm