



# FIELD KIT

Vermeer Corporation

Environmental  
Pella, IA 50219 USA

<b>FIELD CAMPAIGN KIT#</b>	<b>IK003922</b>	<b>DATE:</b>	<b>18 June 2020</b>
<i>For Dealer Reference: Service Bulletin #SVC2020-083</i>			
<b>BC1500 Wheel and Tire Assembly Replacement KIT</b>			

<b>CAMPAIGN TYPE:</b>	<b>Mandatory Product Safety <b>DEALER INSTALLATION ONLY</b></b>
<b>CAMPAIGN CATEGORY:</b>	<b>Kit and Bulletin</b>

MACHINE/ ATTACHMENT MODEL(S):	Serial Numbers		
	Included	Excluded	Kit Version
BC1500	See attached listing on pages 3-15 of this bulletin for specific VIN and Serial/Unit numbers	1082, 8357, 8442, 8628, 8629, 8717 – 8720, 8757, 8794, 8885, 8893, 8940, 8949, 8954, 8961, 8984, 8986, 8989, 8999, 9014, 9015, 9030, 9032, 9214, 9241, 9250, 9251, 9295, 9311, 9317, 9320, 9403, 9431, 9493, 9578, 9579, 9583, 9599, 9602, 9616, 9617, 9624, 9711, 9779, 9798, 9854, 9865, 9866, 9878, 9897, 9908, 9924, 9925,	<b>IK01: Solid Steel Wheels</b> 8 on 6 1/2", 5/8" studs; <b>Heavy Duty Tires</b> 235/75R17.5 LRJ 18 ply; safety sign and <b>English Supplemental Manual.</b>
BC1500	1082, 8357, 8442, 8628, 8629, 8717 – 8720, 8757, 8794, 8885, 8893, 8940, 8949, 8954, 8961, 8984, 8986, 8989, 8999, 9014, 9015, 9030, 9032, 9214, 9241, 9250, 9251, 9295, 9311, 9317, 9320, 9403, 9431, 9493, 9578, 9579, 9583, 9599, 9602, 9616, 9617, 9624, 9711, 9779, 9798, 9854, 9865, 9866, 9878, 9897, 9908, 9924, 9925,	See attached listing on pages 3-15 of this bulletin for specific VIN and Serial/Unit numbers	<b>IK02: Solid Steel Wheels</b> 8 on 6 1/2", 5/8" studs; <b>Heavy Duty Tires</b> 235/75R17.5 LRJ 18 ply; safety sign and <b>English + Translated Supplemental Manual.</b>

MACHINE/ ATTACHMENT MODEL(S):	Serial Numbers		
	Included	Excluded	Kit Version
<b>BC1500</b> Temporary wheel/tire assembly solution (Assembly PN 163759457) previously installed	See attached listing on page 16 of this bulletin for specific VIN and Serial/Unit numbers	NONE	<b>IK03:</b> Safety sign and English Supplemental Manual.
<b>BC1500</b> Temporary wheel/tire assembly solution (Assembly PN 163759457) previously installed	NONE (Current location of machines indicate <b>IK04</b> is not required.)	See attached listing on page 16 of this bulletin for specific VIN and Serial/Unit numbers	<b>IK04:</b> Safety sign and English + <b>Translated</b> Supplemental Manual.

**AFFECTED MACHINES - IK01-3922**

MODEL	VIN	MODEL	VIN	MODEL	VIN
BC1500	1VR2161V371001022	BC1500	1VR2161V5D1005374	BC1500	1VR2181V5H1008342
BC1500	1VR2161V771001105	BC1500	1VR2161V5D1005441	BC1500	1VR2181V7H1008343
BC1500	1VR2161V971001168	BC1500	1VR2161V2D1005476	BC1500	1VR2181V9H1008344
BC1500	1VR2161V871001209	BC1500	1VR2161V9D1005510	BC1500	1VR2181V0H1008345
BC1500	1VR2161V471001224	BC1500	1VR2161V8D1005532	BC1500	1VR2181V2H1008346
BC1500	1VR2161V971001249	BC1500	1VR2161V5D1005603	BC1500	1VR2161V9H1008347
BC1500	1VR2161V181001277	BC1500	1VR2161V4D1005656	BC1500	1VR2161V9H1008350
BC1500	1VR2161V681001288	BC1500	1VR2161VXE1005825	BC1500	1VR2181V6H1008351
BC1500	1VR2161V181001294	BC1500	1VR2161V4E1005920	BC1500	1VR2161V2H1008352
BC1500	1VR2161V081001304	BC1500	1VR2161V7E1006043	BC1500	1VR2161V4H1008353
BC1500	1VR2161VX81001407	BC1500	1VR2161V6E1006065	BC1500	1VR2161V6H1008354
BC1500	1VR2161V881001437	BC1500	1VR2161V7E1006155	BC1500	1VR2181V3H1008355
BC1500	1VR2161V381001457	BC1500	1VR2161VXE1006196	BC1500	1VR2181V5H1008356
BC1500	1VR2161VX81001522	BC1500	1VR2161V3F1006316	BC1500	1VR2161V3H1008358
BC1500	1VR2161V191002043	BC1500	1VR2161V6F1006326	BC1500	1VR2161V5H1008359
BC1500	1VR2161V491002053	BC1500	1VR2161V7F1006335	BC1500	1VR2161V1H1008360
BC1500	1VR2161VX91002056	BC1500	1VR2161V2F1006503	BC1500	1VR2161V3H1008361
BC1500	1VR2161V491002098	BC1500	1VR2181VXG1008156	BC1500	1VR2161V5H1008362
BC1500	1VR2161V191002110	BC1500	1VR2181V1G1008286	BC1500	1VR2161V7H1008363
BC1500	1VR2161V291002133	BC1500	1VR2181V7G1008311	BC1500	1VR2181V4H1008364
BC1500	1VR2161V591002255	BC1500	1VR2181V4H1008316	BC1500	1VR2181V6H1008365
BC1500	1VR2161V9A1002375	BC1500	1VR2181V6H1008317	BC1500	1VR2181V8H1008366
BC1500	1VR2161V4A1002378	BC1500	1VR2181VXH1008319	BC1500	1VR2181VXH1008367
BC1500	1VR2161V4A1002400	BC1500	1VR2181V6H1008320	BC1500	1VR2181V1H1008368
BC1500	1VR2161V2A1002508	BC1500	1VR2181V8H1008321	BC1500	1VR2181V3H1008369
BC1500	1VR2161V5B1002651	BC1500	1VR2181VXH1008322	BC1500	1VR2181VXH1008370
BC1500	1VR2161V3B1002664	BC1500	1VR2181V1H1008323	BC1500	1VR2181V1H1008371
BC1500	1VR2161V2B1002669	BC1500	1VR2181V3H1008324	BC1500	1VR2181V3H1008372
BC1500	1VR2161V2B1002719	BC1500	1VR2181V5H1008325	BC1500	1VR2181V5H1008373
BC1500	1VR2161V1B1002761	BC1500	1VR2181V7H1008326	BC1500	1VR2181V7H1008374
BC1500	1VR2161V7B1002795	BC1500	1VR2181V9H1008327	BC1500	1VR2181V9H1008375
BC1500	1VR2161V2B1002798	BC1500	1VR2181V0H1008328	BC1500	1VR2181V2H1008377
BC1500	1VR2161V3C1002956	BC1500	1VR2181V2H1008329	BC1500	1VR2181V2H1008380
BC1500	1VR2161VXC1002971	BC1500	1VR2181V9H1008330	BC1500	1VR2181V4H1008381
BC1500	1VR2161V1C1002972	BC1500	1VR2181V0H1008331	BC1500	1VR2181V6H1008382
BC1500	1VR2161V7C1002975	BC1500	1VR2181V2H1008332	BC1500	1VR2181V8H1008383
BC1500	1VR2161V7C1003012	BC1500	1VR2181V4H1008333	BC1500	1VR2181VXH1008384
BC1500	1VR2161V2C1003015	BC1500	1VR2181V8H1008335	BC1500	1VR2181V1H1008385
BC1500	1VR2161V6C1003048	BC1500	1VR2181V1H1008337	BC1500	1VR2161V8H1008386
BC1500	1VR2161V2C1003130	BC1500	1VR2181V3H1008338	BC1500	1VR2161VXH1008387
BC1500	1VR2161V0C1005040	BC1500	1VR2181V5H1008339	BC1500	1VR2161V1H1008388
BC1500	1VR2161V7C1005049	BC1500	1VR2181V1H1008340	BC1500	1VR2181V9H1008389
BC1500	1VR2161VXD1005323	BC1500	1VR2181V3H1008341	BC1500	1VR2161VXH1008390

**AFFECTED MACHINES - IK01-3922**

MODEL	VIN	MODEL	VIN	MODEL	VIN
BC1500	1VR2181V7H1008391	BC1500	1VR2181V5H1008437	BC1500	1VR2181V2H1008492
BC1500	1VR2161V3H1008392	BC1500	1VR2181V7H1008438	BC1500	1VR2181V4H1008493
BC1500	1VR2181V0H1008393	BC1500	1VR2181V9H1008439	BC1500	1VR2181V6H1008494
BC1500	1VR2161V7H1008394	BC1500	1VR2161VXH1008440	BC1500	1VR2181V8H1008495
BC1500	1VR2161V9H1008395	BC1500	1VR2161V1H1008441	BC1500	1VR2181V1H1008497
BC1500	1VR2161V0H1008396	BC1500	1VR2181V2H1008444	BC1500	1VR2181V3H1008498
BC1500	1VR2161V2H1008397	BC1500	1VR2181V4H1008445	BC1500	1VR2181V5H1008499
BC1500	1VR2181VXH1008398	BC1500	1VR2181V6H1008446	BC1500	1VR2181V8H1008500
BC1500	1VR2181V1H1008399	BC1500	1VR2181V8H1008447	BC1500	1VR2181VXH1008501
BC1500	1VR2181V4H1008400	BC1500	1VR2181VXH1008448	BC1500	1VR2181V1H1008502
BC1500	1VR2181V6H1008401	BC1500	1VR2181V8H1008450	BC1500	1VR2181V3H1008503
BC1500	1VR2181V8H1008402	BC1500	1VR2181VXH1008451	BC1500	1VR2181V5H1008504
BC1500	1VR2181VXH1008403	BC1500	1VR2181V1H1008452	BC1500	1VR2181V7H1008505
BC1500	1VR2181V1H1008404	BC1500	1VR2181V3H1008453	BC1500	1VR2181V9H1008506
BC1500	1VR2181V3H1008405	BC1500	1VR2181V5H1008454	BC1500	1VR2162V7H1008507
BC1500	1VR2181V5H1008406	BC1500	1VR2181V7H1008455	BC1500	1VR2162V9H1008508
BC1500	1VR2181V7H1008407	BC1500	1VR2181V9H1008456	BC1500	1VR2181V4H1008509
BC1500	1VR2181V9H1008408	BC1500	1VR2181V2H1008458	BC1500	1VR2181V0H1008510
BC1500	1VR2181V0H1008409	BC1500	1VR2181V4H1008459	BC1500	1VR2181V2H1008511
BC1500	1VR2181V7H1008410	BC1500	1VR2181V0H1008460	BC1500	1VR2181V4H1008512
BC1500	1VR2181V0H1008412	BC1500	1VR2181V2H1008461	BC1500	1VR2181V6H1008513
BC1500	1VR2181V2H1008413	BC1500	1VR2181V4H1008462	BC1500	1VR2181V8H1008514
BC1500	1VR2181V4H1008414	BC1500	1VR2181V6H1008463	BC1500	1VR2181VXH1008515
BC1500	1VR2181V6H1008415	BC1500	1VR2181VXH1008465	BC1500	1VR2181V1H1008516
BC1500	1VR2181V8H1008416	BC1500	1VR2181V3H1008470	BC1500	1VR2181V3H1008517
BC1500	1VR2181VXH1008417	BC1500	1VR2181V5H1008471	BC1500	1VR2181V5H1008518
BC1500	1VR2181V1H1008418	BC1500	1VR2161V1H1008472	BC1500	1VR2161V8H1008520
BC1500	1VR2181V3H1008419	BC1500	1VR2161V3H1008473	BC1500	1VR2161V1H1008522
BC1500	1VR2181VXH1008420	BC1500	1VR2181V0H1008474	BC1500	1VR2161V3H1008523
BC1500	1VR2181V1H1008421	BC1500	1VR2181V2H1008475	BC1500	1VR2161V5H1008524
BC1500	1VR2181V3H1008422	BC1500	1VR2181V4H1008476	BC1500	1VR2181V2H1008525
BC1500	1VR2181V5H1008423	BC1500	1VR2181V8H1008478	BC1500	1VR2181V4H1008526
BC1500	1VR2181V7H1008424	BC1500	1VR2181V6H1008480	BC1500	1VR2181V6H1008527
BC1500	1VR2181V9H1008425	BC1500	1VR2181V8H1008481	BC1500	1VR2181V8H1008528
BC1500	1VR2181V0H1008426	BC1500	1VR2181VXH1008482	BC1500	1VR2181VXH1008529
BC1500	1VR2181V2H1008427	BC1500	1VR2181V1H1008483	BC1500	1VR2181V6H1008530
BC1500	1VR2181V4H1008428	BC1500	1VR2181V3H1008484	BC1500	1VR2181V8H1008531
BC1500	1VR2181V6H1008429	BC1500	1VR2181V5H1008485	BC1500	1VR2181VXH1008532
BC1500	1VR2181V2H1008430	BC1500	1VR2181V9H1008487	BC1500	1VR2181V1H1008533
BC1500	1VR2181V4H1008431	BC1500	1VR2181V0H1008488	BC1500	1VR2181V3H1008534
BC1500	1VR2181V8H1008433	BC1500	1VR2181V2H1008489	BC1500	1VR2181V5H1008535
BC1500	1VR2181VXH1008434	BC1500	1VR2181V9H1008490	BC1500	1VR2181V7H1008536
BC1500	1VR2181V3H1008436	BC1500	1VR2181V0H1008491	BC1500	1VR2181V9H1008537



**AFFECTED MACHINES - IK01-3922**

MODEL	VIN	MODEL	VIN	MODEL	VIN
BC1500	1VR2181V0H1008538	BC1500	1VR2161VXH1008583	BC1500	1VR2161V6H1008631
BC1500	1VR2181V2H1008539	BC1500	1VR2161V1H1008584	BC1500	1VR2161V8H1008632
BC1500	1VR2181V9H1008540	BC1500	1VR2161V3H1008585	BC1500	1VR2161V1H1008634
BC1500	1VR2181V0H1008541	BC1500	1VR2181V0H1008586	BC1500	1VR2181V9H1008635
BC1500	1VR2181V2H1008542	BC1500	1VR2181V2H1008587	BC1500	1VR2181V0H1008636
BC1500	1VR2181V4H1008543	BC1500	1VR2181V4H1008588	BC1500	1VR2181V2H1008637
BC1500	1VR2161V0H1008544	BC1500	1VR2181V6H1008589	BC1500	1VR2181V4H1008638
BC1500	1VR2181V8H1008545	BC1500	1VR2181V2H1008590	BC1500	1VR2181V4H1008641
BC1500	1VR2181VXH1008546	BC1500	1VR2181V4H1008591	BC1500	1VR2181V6H1008642
BC1500	1VR2161V6H1008547	BC1500	1VR2181V8H1008593	BC1500	1VR2181V8H1008643
BC1500	1VR2181V3H1008548	BC1500	1VR2181VXH1008594	BC1500	1VR2181VXH1008644
BC1500	1VR2181V5H1008549	BC1500	1VR2181V1H1008595	BC1500	1VR2181V1H1008645
BC1500	1VR2181V3H1008551	BC1500	1VR2181V3H1008596	BC1500	1VR2181V3H1008646
BC1500	1VR2161VXH1008552	BC1500	1VR2181V5H1008597	BC1500	1VR2181V5H1008647
BC1500	1VR2181V7H1008553	BC1500	1VR2181V7H1008598	BC1500	1VR2181V7H1008648
BC1500	1VR2161V3H1008554	BC1500	1VR2181V9H1008599	BC1500	1VR2181V9H1008649
BC1500	1VR2181V0H1008555	BC1500	1VR2181V1H1008600	BC1500	1VR2181V5H1008650
BC1500	1VR2161V7H1008556	BC1500	1VR2181V5H1008602	BC1500	1VR2181V7H1008651
BC1500	1VR2181V4H1008557	BC1500	1VR2181V7H1008603	BC1500	1VR2181V9H1008652
BC1500	1VR2161V0H1008558	BC1500	1VR2181V9H1008604	BC1500	1VR2181V0H1008653
BC1500	1VR2161V2H1008559	BC1500	1VR2181V0H1008605	BC1500	1VR2181V2H1008654
BC1500	1VR2161V9H1008560	BC1500	1VR2181V2H1008606	BC1500	1VR2181V4H1008655
BC1500	1VR2181V6H1008561	BC1500	1VR2181V4H1008607	BC1500	1VR2181V6H1008656
BC1500	1VR2161V2H1008562	BC1500	1VR2181V6H1008608	BC1500	1VR2181V8H1008657
BC1500	1VR2161V4H1008563	BC1500	1VR2181V8H1008609	BC1500	1VR2181VXH1008658
BC1500	1VR2181V3H1008565	BC1500	1VR2181V4H1008610	BC1500	1VR2181V1H1008659
BC1500	1VR2181V5H1008566	BC1500	1VR2181V6H1008611	BC1500	1VR2181V8H1008660
BC1500	1VR2181V7H1008567	BC1500	1VR2181V8H1008612	BC1500	1VR2181VXH1008661
BC1500	1VR2181V9H1008568	BC1500	1VR2181VXH1008613	BC1500	1VR2181V1H1008662
BC1500	1VR2181V0H1008569	BC1500	1VR2181V1H1008614	BC1500	1VR2181V3H1008663
BC1500	1VR2181V7H1008570	BC1500	1VR2181V3H1008615	BC1500	1VR2181V5H1008664
BC1500	1VR2181V9H1008571	BC1500	1VR2181V5H1008616	BC1500	1VR2181V7H1008665
BC1500	1VR2181V0H1008572	BC1500	1VR2181V7H1008617	BC1500	1VR2181V9H1008666
BC1500	1VR2181V2H1008573	BC1500	1VR2181V0H1008619	BC1500	1VR2181V0H1008667
BC1500	1VR2181V4H1008574	BC1500	1VR2181V7H1008620	BC1500	1VR2181V2H1008668
BC1500	1VR2181V6H1008575	BC1500	1VR2181V9H1008621	BC1500	1VR2181V4H1008669
BC1500	1VR2181V8H1008576	BC1500	1VR2181V0H1008622	BC1500	1VR2181V0H1008670
BC1500	1VR2181VXH1008577	BC1500	1VR2181V2H1008623	BC1500	1VR2181V2H1008671
BC1500	1VR2181V1H1008578	BC1500	1VR2181V4H1008624	BC1500	1VR2181V4H1008672
BC1500	1VR2181V3H1008579	BC1500	1VR2181V6H1008625	BC1500	1VR2181V6H1008673
BC1500	1VR2161V4H1008580	BC1500	1VR2181V8H1008626	BC1500	1VR2181V8H1008674
BC1500	1VR2161V6H1008581	BC1500	1VR2181VXH1008627	BC1500	1VR2181VXH1008675
BC1500	1VR2181V3H1008582	BC1500	1VR2161V4H1008630	BC1500	1VR2181V1H1008676

**AFFECTED MACHINES - IK01-3922**

MODEL	VIN	MODEL	VIN	MODEL	VIN
BC1500	1VR2181V3H1008677	BC1500	1VR2181V5H1008728	BC1500	1VR2181V2J1008773
BC1500	1VR2181V5H1008678	BC1500	1VR2181V7H1008729	BC1500	1VR2181V6J1008775
BC1500	1VR2181V7H1008679	BC1500	1VR2181V3H1008730	BC1500	1VR2181V8J1008776
BC1500	1VR2181V3H1008680	BC1500	1VR2181V5H1008731	BC1500	1VR2181VXJ1008777
BC1500	1VR2181V5H1008681	BC1500	1VR2161V1H1008732	BC1500	1VR2181V1J1008778
BC1500	1VR2181V7H1008682	BC1500	1VR2161V3H1008733	BC1500	1VR2181V3J1008779
BC1500	1VR2181V9H1008683	BC1500	1VR2181V0H1008734	BC1500	1VR2181VXJ1008780
BC1500	1VR2181V0H1008684	BC1500	1VR2181V2H1008735	BC1500	1VR2181V1J1008781
BC1500	1VR2181V2H1008685	BC1500	1VR2181V4H1008736	BC1500	1VR2181V3J1008782
BC1500	1VR2181V4H1008686	BC1500	1VR2181V6H1008737	BC1500	1VR2161VXJ1008783
BC1500	1VR2181V6H1008687	BC1500	1VR2161V2H1008738	BC1500	1VR2161V1J1008784
BC1500	1VR2181V8H1008688	BC1500	1VR2161V4H1008739	BC1500	1VR2161V3J1008785
BC1500	1VR2161V4H1008689	BC1500	1VR2181V6H1008740	BC1500	1VR2161V5J1008786
BC1500	1VR2161V0H1008690	BC1500	1VR2181V8H1008741	BC1500	1VR2181V2J1008787
BC1500	1VR2181V8H1008691	BC1500	1VR2181VXH1008742	BC1500	1VR2181V4J1008788
BC1500	1VR2181V1H1008693	BC1500	1VR2181V1H1008743	BC1500	1VR2181V6J1008789
BC1500	1VR2181V3H1008694	BC1500	1VR2181V3H1008744	BC1500	1VR2181V2J1008790
BC1500	1VR2181V5H1008695	BC1500	1VR2181V5H1008745	BC1500	1VR2181V4J1008791
BC1500	1VR2181V7H1008696	BC1500	1VR2181V7H1008746	BC1500	1VR2181V6J1008792
BC1500	1VR2181V9H1008697	BC1500	1VR2181V9H1008747	BC1500	1VR2181V3J1008796
BC1500	1VR2181V0H1008698	BC1500	1VR2181V0H1008748	BC1500	1VR2181V5J1008797
BC1500	1VR2181V2H1008699	BC1500	1VR2181V2H1008749	BC1500	1VR2181V7J1008798
BC1500	1VR2181V5H1008700	BC1500	1VR2181V0H1008751	BC1500	1VR2181V1J1008800
BC1500	1VR2181V7H1008701	BC1500	1VR2181V2H1008752	BC1500	1VR2181V3J1008801
BC1500	1VR2181V9H1008702	BC1500	1VR2161V9H1008753	BC1500	1VR2181V5J1008802
BC1500	1VR2181V0H1008703	BC1500	1VR2181V6H1008754	BC1500	1VR2181V7J1008803
BC1500	1VR2181V2H1008704	BC1500	1VR2181V8H1008755	BC1500	1VR2181V9J1008804
BC1500	1VR2181V4H1008705	BC1500	1VR2161V4H1008756	BC1500	1VR2181V0J1008805
BC1500	1VR2181V6H1008706	BC1500	1VR2181V3H1008758	BC1500	1VR2181V2J1008806
BC1500	1VR2181V8H1008707	BC1500	1VR2181V5H1008759	BC1500	1VR2181V4J1008807
BC1500	1VR2181VXH1008708	BC1500	1VR2181V1H1008760	BC1500	1VR2161V0J1008808
BC1500	1VR2181V1H1008709	BC1500	1VR2181V3H1008761	BC1500	1VR2181V8J1008809
BC1500	1VR2181V8H1008710	BC1500	1VR2181V5H1008762	BC1500	1VR2181V4J1008810
BC1500	1VR2181VXH1008711	BC1500	1VR2161V4J1008763	BC1500	1VR2181V6J1008811
BC1500	1VR2181V1H1008712	BC1500	1VR2181V1J1008764	BC1500	1VR2181V8J1008812
BC1500	1VR2181V3H1008713	BC1500	1VR2181V3J1008765	BC1500	1VR2181VXJ1008813
BC1500	1VR2181V5H1008714	BC1500	1VR2181V5J1008766	BC1500	1VR2161V6J1008814
BC1500	1VR2181V7H1008715	BC1500	1VR2181V7J1008767	BC1500	1VR2181V3J1008815
BC1500	1VR2161V7H1008721	BC1500	1VR2181V9J1008768	BC1500	1VR2181V5J1008816
BC1500	1VR2181V6H1008723	BC1500	1VR2161V5J1008769	BC1500	1VR2181V7J1008817
BC1500	1VR2181V8H1008724	BC1500	1VR2181V7J1008770	BC1500	1VR2181V9J1008818
BC1500	1VR2181VXH1008725	BC1500	1VR2181V9J1008771	BC1500	1VR2181V0J1008819
BC1500	1VR2181V1H1008726	BC1500	1VR2181V0J1008772	BC1500	1VR2181V7J1008820

**AFFECTED MACHINES - IK01-3922**

MODEL	VIN	MODEL	VIN	MODEL	VIN
BC1500	1VR2181V9J1008821	BC1500	1VR2181V2J1008868	BC1500	1VR2181V0J1008917
BC1500	1VR2181V0J1008822	BC1500	1VR2181V4J1008869	BC1500	1VR2181V2J1008918
BC1500	1VR2181V2J1008823	BC1500	1VR2181V0J1008870	BC1500	1VR2181V4J1008919
BC1500	1VR2181V4J1008824	BC1500	1VR2181V2J1008871	BC1500	1VR2181V0J1008920
BC1500	1VR2181V6J1008825	BC1500	1VR2181V4J1008872	BC1500	1VR2181V2J1008921
BC1500	1VR2161V2J1008826	BC1500	1VR2181V6J1008873	BC1500	1VR2161V9J1008922
BC1500	1VR2181VXJ1008827	BC1500	1VR2181V8J1008874	BC1500	1VR2181V6J1008923
BC1500	1VR2181V1J1008828	BC1500	1VR2181VXJ1008875	BC1500	1VR2181V8J1008924
BC1500	1VR2181V3J1008829	BC1500	1VR2181V1J1008876	BC1500	1VR2181VXJ1008925
BC1500	1VR2181VXJ1008830	BC1500	1VR2181V3J1008877	BC1500	1VR2181V1J1008926
BC1500	1VR2181V1J1008831	BC1500	1VR2181V5J1008878	BC1500	1VR2181V3J1008927
BC1500	1VR2181V3J1008832	BC1500	1VR2181V3J1008880	BC1500	1VR2181V5J1008928
BC1500	1VR2181V5J1008833	BC1500	1VR2181V5J1008881	BC1500	1VR2181V7J1008929
BC1500	1VR2181V7J1008834	BC1500	1VR2181V7J1008882	BC1500	1VR2181V3J1008930
BC1500	1VR2181V9J1008835	BC1500	1VR2181V9J1008883	BC1500	1VR2161VXJ1008931
BC1500	1VR2181V0J1008836	BC1500	1VR2181V0J1008884	BC1500	1VR2181V7J1008932
BC1500	1VR2161V7J1008837	BC1500	1VR2181V4J1008886	BC1500	1VR2181V9J1008933
BC1500	1VR2181V4J1008838	BC1500	1VR2181V6J1008887	BC1500	1VR2181V0J1008934
BC1500	1VR2181V6J1008839	BC1500	1VR2181V8J1008888	BC1500	1VR2181V2J1008935
BC1500	1VR2181V2J1008840	BC1500	1VR2181VXJ1008889	BC1500	1VR2181V4J1008936
BC1500	1VR2181V4J1008841	BC1500	1VR2181V6J1008890	BC1500	1VR2181V6J1008937
BC1500	1VR2181V6J1008842	BC1500	1VR2181VXJ1008892	BC1500	1VR2181V8J1008938
BC1500	1VR2181V8J1008843	BC1500	1VR2181V3J1008894	BC1500	1VR2181VXJ1008939
BC1500	1VR2181VXJ1008844	BC1500	1VR2181V5J1008895	BC1500	1VR2181V8J1008941
BC1500	1VR2181V1J1008845	BC1500	1VR2181V7J1008896	BC1500	1VR2181VXJ1008942
BC1500	1VR2181V3J1008846	BC1500	1VR2181V9J1008897	BC1500	1VR2181V1J1008943
BC1500	1VR2181V5J1008847	BC1500	1VR2181V0J1008898	BC1500	1VR2181V3J1008944
BC1500	1VR2181V7J1008848	BC1500	1VR2181V2J1008899	BC1500	1VR2181V5J1008945
BC1500	1VR2181V9J1008849	BC1500	1VR2181V5J1008900	BC1500	1VR2181V7J1008946
BC1500	1VR2181V5J1008850	BC1500	1VR2181V7J1008901	BC1500	1VR2181V9J1008947
BC1500	1VR2181V7J1008851	BC1500	1VR2181V0J1008903	BC1500	1VR2181V0J1008948
BC1500	1VR2181V9J1008852	BC1500	1VR2181V2J1008904	BC1500	1VR2181V9J1008950
BC1500	1VR2181V0J1008853	BC1500	1VR2181V4J1008905	BC1500	1VR2181V0J1008951
BC1500	1VR2181V8J1008857	BC1500	1VR2181V6J1008906	BC1500	1VR2181V2J1008952
BC1500	1VR2181VXJ1008858	BC1500	1VR2181V8J1008907	BC1500	1VR2181V4J1008953
BC1500	1VR2181V1J1008859	BC1500	1VR2181VXJ1008908	BC1500	1VR2181V8J1008955
BC1500	1VR2181V8J1008860	BC1500	1VR2181V1J1008909	BC1500	1VR2181VXJ1008956
BC1500	1VR2181VXJ1008861	BC1500	1VR2181V8J1008910	BC1500	1VR2181V1J1008957
BC1500	1VR2181V1J1008862	BC1500	1VR2181VXJ1008911	BC1500	1VR2181V3J1008958
BC1500	1VR2181V5J1008864	BC1500	1VR2181V1J1008912	BC1500	1VR2181V5J1008959
BC1500	1VR2181V7J1008865	BC1500	1VR2181V3J1008913	BC1500	1VR2181V1J1008960
BC1500	1VR2181V9J1008866	BC1500	1VR2181V5J1008914	BC1500	1VR2181V5J1008962
BC1500	1VR2181V0J1008867	BC1500	1VR2181V9J1008916	BC1500	1VR2181V7J1008963



### AFFECTED MACHINES - IK01-3922

MODEL	VIN	MODEL	VIN	MODEL	VIN
BC1500	1VR2181V9J1008964	BC1500	1VR2181V2J1009017	BC1500	1VR2161V5J1009064
BC1500	1VR2181V0J1008965	BC1500	1VR2181V4J1009018	BC1500	1VR2181V2J1009065
BC1500	1VR2181V2J1008966	BC1500	1VR2181V6J1009019	BC1500	1VR2161V9J1009066
BC1500	1VR2181V4J1008967	BC1500	1VR2181V2J1009020	BC1500	1VR2181V6J1009067
BC1500	1VR2181V6J1008968	BC1500	1VR2181V4J1009021	BC1500	1VR2161V2J1009068
BC1500	1VR2181V8J1008969	BC1500	1VR2181V6J1009022	BC1500	1VR2181VXJ1009069
BC1500	1VR2181V4J1008970	BC1500	1VR2181V8J1009023	BC1500	1VR2161V0J1009070
BC1500	1VR2181V6J1008971	BC1500	1VR2181VXJ1009024	BC1500	1VR2181V8J1009071
BC1500	1VR2181V1J1008974	BC1500	1VR2181V1J1009025	BC1500	1VR2181VXJ1009072
BC1500	1VR2181V3J1008975	BC1500	1VR2181V3J1009026	BC1500	1VR2181V1J1009073
BC1500	1VR2181V5J1008976	BC1500	1VR2181V5J1009027	BC1500	1VR2161V8J1009074
BC1500	1VR2181V7J1008977	BC1500	1VR2181V7J1009028	BC1500	1VR2181V5J1009075
BC1500	1VR2181V9J1008978	BC1500	1VR2181V9J1009029	BC1500	1VR2161V1J1009076
BC1500	1VR2181V0J1008979	BC1500	1VR2181V7J1009031	BC1500	1VR2181V9J1009077
BC1500	1VR2181V7J1008980	BC1500	1VR2181V0J1009033	BC1500	1VR2161V5J1009078
BC1500	1VR2181V9J1008981	BC1500	1VR2181V2J1009034	BC1500	1VR2181V2J1009079
BC1500	1VR2181V0J1008982	BC1500	1VR2181V4J1009035	BC1500	1VR2161V3J1009080
BC1500	1VR2181V2J1008983	BC1500	1VR2181V6J1009036	BC1500	1VR2181V0J1009081
BC1500	1VR2181V6J1008985	BC1500	1VR2181V8J1009037	BC1500	1VR2181V2J1009082
BC1500	1VR2181VXJ1008987	BC1500	1VR2181VXJ1009038	BC1500	1VR2181V4J1009083
BC1500	1VR2181V1J1008988	BC1500	1VR2181V1J1009039	BC1500	1VR2181V6J1009084
BC1500	1VR2181VXJ1008990	BC1500	1VR2181V8J1009040	BC1500	1VR2181V8J1009085
BC1500	1VR2181V1J1008991	BC1500	1VR2181VXJ1009041	BC1500	1VR2181VXJ1009086
BC1500	1VR2181V3J1008992	BC1500	1VR2181V1J1009042	BC1500	1VR2161V6J1009087
BC1500	1VR2181V5J1008993	BC1500	1VR2181V3J1009043	BC1500	1VR2181V3J1009088
BC1500	1VR2181V7J1008994	BC1500	1VR2181V5J1009044	BC1500	1VR2181V1J1009090
BC1500	1VR2181V9J1008995	BC1500	1VR2161V1J1009045	BC1500	1VR2181V5J1009092
BC1500	1VR2181V2J1008997	BC1500	1VR2161V5J1009047	BC1500	1VR2181V9J1009094
BC1500	1VR2181V4J1008998	BC1500	1VR2181V2J1009048	BC1500	1VR2181V0J1009095
BC1500	1VR2181V7J1009000	BC1500	1VR2161V9J1009049	BC1500	1VR2181V2J1009096
BC1500	1VR2181V9J1009001	BC1500	1VR2181V0J1009050	BC1500	1VR2181V4J1009097
BC1500	1VR2181V2J1009003	BC1500	1VR2161V7J1009051	BC1500	1VR2181V6J1009098
BC1500	1VR2181V4J1009004	BC1500	1VR2181V4J1009052	BC1500	1VR2181V0J1009100
BC1500	1VR2161V0J1009005	BC1500	1VR2161V0J1009053	BC1500	1VR2181V2J1009101
BC1500	1VR2181V8J1009006	BC1500	1VR2181V8J1009054	BC1500	1VR2181V6J1009103
BC1500	1VR2181VXJ1009007	BC1500	1VR2181VXJ1009055	BC1500	1VR2181V8J1009104
BC1500	1VR2181V1J1009008	BC1500	1VR2181V1J1009056	BC1500	1VR2181V1J1009106
BC1500	1VR2181V3J1009009	BC1500	1VR2181V3J1009057	BC1500	1VR2181V3J1009107
BC1500	1VR2181VXJ1009010	BC1500	1VR2181V5J1009058	BC1500	1VR2161VXJ1009108
BC1500	1VR2181V1J1009011	BC1500	1VR2181V7J1009059	BC1500	1VR2181V7J1009109
BC1500	1VR2181V3J1009012	BC1500	1VR2181V5J1009061	BC1500	1VR2181V3J1009110
BC1500	1VR2181V5J1009013	BC1500	1VR2161V1J1009062	BC1500	1VR2181V5J1009111
BC1500	1VR2181V0J1009016	BC1500	1VR2181V9J1009063	BC1500	1VR2181V7J1009112



### AFFECTED MACHINES - IK01-3922

MODEL	VIN	MODEL	VIN	MODEL	VIN
BC1500	1VR2181V9J1009113	BC1500	1VR2181V7J1009157	BC1500	1VR2181V8J1009202
BC1500	1VR2181V0J1009114	BC1500	1VR2181V9J1009158	BC1500	1VR2181VXJ1009203
BC1500	1VR2181V2J1009115	BC1500	1VR2181V0J1009159	BC1500	1VR2181V1J1009204
BC1500	1VR2181V4J1009116	BC1500	1VR2181V7J1009160	BC1500	1VR2181V5J1009206
BC1500	1VR2181V6J1009117	BC1500	1VR2181V9J1009161	BC1500	1VR2181V7J1009207
BC1500	1VR2181V8J1009118	BC1500	1VR2181V0J1009162	BC1500	1VR2181V9J1009208
BC1500	1VR2181VXJ1009119	BC1500	1VR2181V2J1009163	BC1500	1VR2181V0J1009209
BC1500	1VR2181V6J1009120	BC1500	1VR2181V4J1009164	BC1500	1VR2181V7J1009210
BC1500	1VR2181V8J1009121	BC1500	1VR2181V6J1009165	BC1500	1VR2181V9J1009211
BC1500	1VR2181VXJ1009122	BC1500	1VR2181V8J1009166	BC1500	1VR2181V0J1009212
BC1500	1VR2181V1J1009123	BC1500	1VR2181VXJ1009167	BC1500	1VR2181V2J1009213
BC1500	1VR2181V3J1009124	BC1500	1VR2181V1J1009168	BC1500	1VR2181V6J1009215
BC1500	1VR2181V5J1009125	BC1500	1VR2181V3J1009169	BC1500	1VR2181V8J1009216
BC1500	1VR2181V7J1009126	BC1500	1VR2181VXJ1009170	BC1500	1VR2181VXJ1009217
BC1500	1VR2181V9J1009127	BC1500	1VR2181V1J1009171	BC1500	1VR2181V1J1009218
BC1500	1VR2181V0J1009128	BC1500	1VR2181V3J1009172	BC1500	1VR2181V3J1009219
BC1500	1VR2181V2J1009129	BC1500	1VR2181V5J1009173	BC1500	1VR2181VXJ1009220
BC1500	1VR2181V9J1009130	BC1500	1VR2181V7J1009174	BC1500	1VR2181V1J1009221
BC1500	1VR2181V0J1009131	BC1500	1VR2181V9J1009175	BC1500	1VR2181V3J1009222
BC1500	1VR2181V2J1009132	BC1500	1VR2181V0J1009176	BC1500	1VR2181V5J1009223
BC1500	1VR2181V4J1009133	BC1500	1VR2181V2J1009177	BC1500	1VR2181V7J1009224
BC1500	1VR2181V8J1009135	BC1500	1VR2181V4J1009178	BC1500	1VR2181V9J1009225
BC1500	1VR2181VXJ1009136	BC1500	1VR2181V6J1009179	BC1500	1VR2181V4J1009228
BC1500	1VR2181V1J1009137	BC1500	1VR2181V4J1009181	BC1500	1VR2181V6J1009229
BC1500	1VR2181V3J1009138	BC1500	1VR2181V6J1009182	BC1500	1VR2181V2J1009230
BC1500	1VR2181V5J1009139	BC1500	1VR2181V8J1009183	BC1500	1VR2181V4J1009231
BC1500	1VR2181V1J1009140	BC1500	1VR2181VXJ1009184	BC1500	1VR2181V6J1009232
BC1500	1VR2181V3J1009141	BC1500	1VR2181V1J1009185	BC1500	1VR2181V8J1009233
BC1500	1VR2181V5J1009142	BC1500	1VR2181V3J1009186	BC1500	1VR2181VXJ1009234
BC1500	1VR2181V7J1009143	BC1500	1VR2181V5J1009187	BC1500	1VR2181V1J1009235
BC1500	1VR2181V9J1009144	BC1500	1VR2181V7J1009188	BC1500	1VR2181V3J1009236
BC1500	1VR2181V0J1009145	BC1500	1VR2181V9J1009189	BC1500	1VR2181V5J1009237
BC1500	1VR2181V2J1009146	BC1500	1VR2181V5J1009190	BC1500	1VR2181V7J1009238
BC1500	1VR2181V4J1009147	BC1500	1VR2181V9J1009192	BC1500	1VR2181V9J1009239
BC1500	1VR2181V6J1009148	BC1500	1VR2181V0J1009193	BC1500	1VR2181V5J1009240
BC1500	1VR2181V8J1009149	BC1500	1VR2181V2J1009194	BC1500	1VR2181V9J1009242
BC1500	1VR2181V4J1009150	BC1500	1VR2181V4J1009195	BC1500	1VR2181V0J1009243
BC1500	1VR2181V6J1009151	BC1500	1VR2181V6J1009196	BC1500	1VR2181V2J1009244
BC1500	1VR2181V8J1009152	BC1500	1VR2161V2J1009197	BC1500	1VR2181V4J1009245
BC1500	1VR2181VXJ1009153	BC1500	1VR2181VXJ1009198	BC1500	1VR2181V6J1009246
BC1500	1VR2181V1J1009154	BC1500	1VR2181V1J1009199	BC1500	1VR2181V8J1009247
BC1500	1VR2181V3J1009155	BC1500	1VR2181V4J1009200	BC1500	1VR2181VXJ1009248
BC1500	1VR2181V5J1009156	BC1500	1VR2181V6J1009201	BC1500	1VR2181V1J1009249

### AFFECTED MACHINES - IK01-3922

MODEL	VIN	MODEL	VIN	MODEL	VIN
BC1500	1VR2181V1J1009252	BC1500	1VR2181V1K1009298	BC1500	1VR2181V6K1009345
BC1500	1VR2181V3J1009253	BC1500	1VR2181V3K1009299	BC1500	1VR2181V8K1009346
BC1500	1VR2181V5J1009254	BC1500	1VR2181V6K1009300	BC1500	1VR2181VXK1009347
BC1500	1VR2181V7J1009255	BC1500	1VR2181V8K1009301	BC1500	1VR2181V1K1009348
BC1500	1VR2181V7K1009256	BC1500	1VR2181VXK1009302	BC1500	1VR2181V3K1009349
BC1500	1VR2181V9K1009257	BC1500	1VR2181V1K1009303	BC1500	1VR2181VXK1009350
BC1500	1VR2181V0K1009258	BC1500	1VR2181V3K1009304	BC1500	1VR2181V1K1009351
BC1500	1VR2181V9K1009260	BC1500	1VR2181V5K1009305	BC1500	1VR2181V3K1009352
BC1500	1VR2181V0K1009261	BC1500	1VR2181V7K1009306	BC1500	1VR2181V5K1009353
BC1500	1VR2181V2K1009262	BC1500	1VR2181V9K1009307	BC1500	1VR2181V7K1009354
BC1500	1VR2181V4K1009263	BC1500	1VR2181V0K1009308	BC1500	1VR2181V9K1009355
BC1500	1VR2181V6K1009264	BC1500	1VR2181V2K1009309	BC1500	1VR2181V0K1009356
BC1500	1VR2181V8K1009265	BC1500	1VR2181V9K1009310	BC1500	1VR2181V2K1009357
BC1500	1VR2181VXK1009266	BC1500	1VR2181V2K1009312	BC1500	1VR2181V4K1009358
BC1500	1VR2161V6K1009267	BC1500	1VR2181V4K1009313	BC1500	1VR2181V6K1009359
BC1500	1VR2181V3K1009268	BC1500	1VR2181V6K1009314	BC1500	1VR2181V2K1009360
BC1500	1VR2181V5K1009269	BC1500	1VR2181V8K1009315	BC1500	1VR2181V4K1009361
BC1500	1VR2181V1K1009270	BC1500	1VR2181VXK1009316	BC1500	1VR2181V6K1009362
BC1500	1VR2181V3K1009271	BC1500	1VR2181V3K1009318	BC1500	1VR2181V8K1009363
BC1500	1VR2181V5K1009272	BC1500	1VR2181V5K1009319	BC1500	1VR2181VXK1009364
BC1500	1VR2181V7K1009273	BC1500	1VR2181V3K1009321	BC1500	1VR2181V1K1009365
BC1500	1VR2181V9K1009274	BC1500	1VR2181V5K1009322	BC1500	1VR2181V3K1009366
BC1500	1VR2181V0K1009275	BC1500	1VR2181V7K1009323	BC1500	1VR2181V5K1009367
BC1500	1VR2181V2K1009276	BC1500	1VR2181V9K1009324	BC1500	1VR2181V7K1009368
BC1500	1VR2181V4K1009277	BC1500	1VR2181V0K1009325	BC1500	1VR2181V9K1009369
BC1500	1VR2181V6K1009278	BC1500	1VR2181V2K1009326	BC1500	1VR2181V5K1009370
BC1500	1VR2181V8K1009279	BC1500	1VR2181V4K1009327	BC1500	1VR2181V7K1009371
BC1500	1VR2181V4K1009280	BC1500	1VR2181V6K1009328	BC1500	1VR2181V9K1009372
BC1500	1VR2181V6K1009281	BC1500	1VR2181V8K1009329	BC1500	1VR2181V0K1009373
BC1500	1VR2181V8K1009282	BC1500	1VR2181V4K1009330	BC1500	1VR2181V2K1009374
BC1500	1VR2181VXK1009283	BC1500	1VR2181V6K1009331	BC1500	1VR2181V4K1009375
BC1500	1VR2181V1K1009284	BC1500	1VR2181V8K1009332	BC1500	1VR2181V6K1009376
BC1500	1VR2181V3K1009285	BC1500	1VR2181VXK1009333	BC1500	1VR2181V8K1009377
BC1500	1VR2181V5K1009286	BC1500	1VR2181V3K1009335	BC1500	1VR2181VXK1009378
BC1500	1VR2181V7K1009287	BC1500	1VR2181V5K1009336	BC1500	1VR2181V1K1009379
BC1500	1VR2181V0K1009289	BC1500	1VR2181V7K1009337	BC1500	1VR2181VXK1009381
BC1500	1VR2181V7K1009290	BC1500	1VR2181V9K1009338	BC1500	1VR2181V1K1009382
BC1500	1VR2181V9K1009291	BC1500	1VR2181V0K1009339	BC1500	1VR2181V3K1009383
BC1500	1VR2181V0K1009292	BC1500	1VR2181V7K1009340	BC1500	1VR2181V5K1009384
BC1500	1VR2181V2K1009293	BC1500	1VR2181V9K1009341	BC1500	1VR2181V7K1009385
BC1500	1VR2181V4K1009294	BC1500	1VR2181V0K1009342	BC1500	1VR2181V9K1009386
BC1500	1VR2181V8K1009296	BC1500	1VR2181V2K1009343	BC1500	1VR2181V0K1009387
BC1500	1VR2181VXK1009297	BC1500	1VR2181V4K1009344	BC1500	1VR2181V2K1009388

**AFFECTED MACHINES - IK01-3922**

MODEL	VIN	MODEL	VIN	MODEL	VIN
BC1500	1VR2181V4K1009389	BC1500	1VR2181V9K1009436	BC1500	1VR2181V1K1009480
BC1500	1VR2181V0K1009390	BC1500	1VR2181V0K1009437	BC1500	1VR2181V3K1009481
BC1500	1VR2181V2K1009391	BC1500	1VR2161V7K1009438	BC1500	1VR2181V5K1009482
BC1500	1VR2181V4K1009392	BC1500	1VR2181V4K1009439	BC1500	1VR2181V7K1009483
BC1500	1VR2181V6K1009393	BC1500	1VR2181V0K1009440	BC1500	1VR2181V9K1009484
BC1500	1VR2181V8K1009394	BC1500	1VR2181V2K1009441	BC1500	1VR2181V0K1009485
BC1500	1VR2181VXK1009395	BC1500	1VR2181V4K1009442	BC1500	1VR2181V2K1009486
BC1500	1VR2181V3K1009397	BC1500	1VR2181V6K1009443	BC1500	1VR2181V4K1009487
BC1500	1VR2181V5K1009398	BC1500	1VR2181V8K1009444	BC1500	1VR2181V6K1009488
BC1500	1VR2181V7K1009399	BC1500	1VR2181VXK1009445	BC1500	1VR2181V8K1009489
BC1500	1VR2181VXK1009400	BC1500	1VR2181V1K1009446	BC1500	1VR2181V4K1009490
BC1500	1VR2181V1K1009401	BC1500	1VR2181V3K1009447	BC1500	1VR2181V6K1009491
BC1500	1VR2181V3K1009402	BC1500	1VR2181V5K1009448	BC1500	1VR2181V8K1009492
BC1500	1VR2181V7K1009404	BC1500	1VR2181V7K1009449	BC1500	1VR2181V1K1009494
BC1500	1VR2181V9K1009405	BC1500	1VR2181V3K1009450	BC1500	1VR2181V3K1009495
BC1500	1VR2181V0K1009406	BC1500	1VR2181V7K1009452	BC1500	1VR2181V5K1009496
BC1500	1VR2181V2K1009407	BC1500	1VR2181V9K1009453	BC1500	1VR2181V7K1009497
BC1500	1VR2181V4K1009408	BC1500	1VR2181V0K1009454	BC1500	1VR2181V9K1009498
BC1500	1VR2181V6K1009409	BC1500	1VR2181V2K1009455	BC1500	1VR2181V0K1009499
BC1500	1VR2181V2K1009410	BC1500	1VR2181V4K1009456	BC1500	1VR2181V3K1009500
BC1500	1VR2181V4K1009411	BC1500	1VR2181V6K1009457	BC1500	1VR2181V5K1009501
BC1500	1VR2181V6K1009412	BC1500	1VR2181V8K1009458	BC1500	1VR2181V7K1009502
BC1500	1VR2181V8K1009413	BC1500	1VR2181VXK1009459	BC1500	1VR2181V9K1009503
BC1500	1VR2181VXK1009414	BC1500	1VR2181V6K1009460	BC1500	1VR2181V0K1009504
BC1500	1VR2181V1K1009415	BC1500	1VR2181V8K1009461	BC1500	1VR2181V2K1009505
BC1500	1VR2181V3K1009416	BC1500	1VR2181VXK1009462	BC1500	1VR2181V4K1009506
BC1500	1VR2181V5K1009417	BC1500	1VR2181V1K1009463	BC1500	1VR2181V6K1009507
BC1500	1VR2181V7K1009418	BC1500	1VR2181V3K1009464	BC1500	1VR2181VXK1009509
BC1500	1VR2181V9K1009419	BC1500	1VR2161VXK1009465	BC1500	1VR2181V6K1009510
BC1500	1VR2181V5K1009420	BC1500	1VR2181V7K1009466	BC1500	1VR2181V8K1009511
BC1500	1VR2181V7K1009421	BC1500	1VR2181V9K1009467	BC1500	1VR2181V1K1009513
BC1500	1VR2181V0K1009423	BC1500	1VR2181V0K1009468	BC1500	1VR2181V3K1009514
BC1500	1VR2181V2K1009424	BC1500	1VR2181V2K1009469	BC1500	1VR2181V5K1009515
BC1500	1VR2181V4K1009425	BC1500	1VR2181V9K1009470	BC1500	1VR2181V7K1009516
BC1500	1VR2181V6K1009426	BC1500	1VR2181V0K1009471	BC1500	1VR2181V9K1009517
BC1500	1VR2181V8K1009427	BC1500	1VR2181V2K1009472	BC1500	1VR2181V0K1009518
BC1500	1VR2181VXK1009428	BC1500	1VR2181V4K1009473	BC1500	1VR2181V2K1009519
BC1500	1VR2181V1K1009429	BC1500	1VR2181V6K1009474	BC1500	1VR2181V9K1009520
BC1500	1VR2181V8K1009430	BC1500	1VR2181V8K1009475	BC1500	1VR2181V0K1009521
BC1500	1VR2181V1K1009432	BC1500	1VR2181VXK1009476	BC1500	1VR2181V2K1009522
BC1500	1VR2181V3K1009433	BC1500	1VR2181V1K1009477	BC1500	1VR2181V4K1009523
BC1500	1VR2181V5K1009434	BC1500	1VR2181V3K1009478	BC1500	1VR2181V6K1009524
BC1500	1VR2181V7K1009435	BC1500	1VR2181V5K1009479	BC1500	1VR2181V8K1009525



### AFFECTED MACHINES - IK01-3922

MODEL	VIN	MODEL	VIN	MODEL	VIN
BC1500	1VR2181VXK1009526	BC1500	1VR2181V4K1009571	BC1500	1VR2181V6K1009622
BC1500	1VR2181V1K1009527	BC1500	1VR2181V6K1009572	BC1500	1VR2181V8K1009623
BC1500	1VR2181V3K1009528	BC1500	1VR2181V8K1009573	BC1500	1VR2181V1K1009625
BC1500	1VR2181V5K1009529	BC1500	1VR2181VXK1009574	BC1500	1VR2181V3K1009626
BC1500	1VR2181V1K1009530	BC1500	1VR2181V1K1009575	BC1500	1VR2181V5K1009627
BC1500	1VR2181V3K1009531	BC1500	1VR2181V3K1009576	BC1500	1VR2181V7K1009628
BC1500	1VR2181V5K1009532	BC1500	1VR2181V5K1009577	BC1500	1VR2181V9K1009629
BC1500	1VR2181V7K1009533	BC1500	1VR2181V5K1009580	BC1500	1VR2181V5K1009630
BC1500	1VR2181V9K1009534	BC1500	1VR2181V7K1009581	BC1500	1VR2181V7K1009631
BC1500	1VR2181V2K1009536	BC1500	1VR2181V9K1009582	BC1500	1VR2181V0K1009633
BC1500	1VR2181V4K1009537	BC1500	1VR2181V2K1009584	BC1500	1VR2181V2K1009634
BC1500	1VR2181V6K1009538	BC1500	1VR2181V4K1009585	BC1500	1VR2181V6K1009636
BC1500	1VR2181V8K1009539	BC1500	1VR2181V6K1009586	BC1500	1VR2181V8K1009637
BC1500	1VR2181V4K1009540	BC1500	1VR2181V8K1009587	BC1500	1VR2181VXK1009638
BC1500	1VR2181V6K1009541	BC1500	1VR2181VXK1009588	BC1500	1VR2181V1K1009639
BC1500	1VR2181V8K1009542	BC1500	1VR2181V1K1009589	BC1500	1VR2181V8K1009640
BC1500	1VR2181VXK1009543	BC1500	1VR2181V8K1009590	BC1500	1VR2181VXK1009641
BC1500	1VR2181V1K1009544	BC1500	1VR2181VXK1009591	BC1500	1VR2181V1K1009642
BC1500	1VR2181V3K1009545	BC1500	1VR2181V1K1009592	BC1500	1VR2181V3K1009643
BC1500	1VR2181V5K1009546	BC1500	1VR2181V3K1009593	BC1500	1VR2181V5K1009644
BC1500	1VR2181V7K1009547	BC1500	1VR2181V5K1009594	BC1500	1VR2181V7K1009645
BC1500	1VR2181V9K1009548	BC1500	1VR2181V7K1009595	BC1500	1VR2181V9K1009646
BC1500	1VR2181V0K1009549	BC1500	1VR2181V9K1009596	BC1500	1VR2181V0K1009647
BC1500	1VR2181V7K1009550	BC1500	1VR2181V0K1009597	BC1500	1VR2181V2K1009648
BC1500	1VR2181V9K1009551	BC1500	1VR2181V2K1009598	BC1500	1VR2181V4K1009649
BC1500	1VR2181V0K1009552	BC1500	1VR2181V9K1009601	BC1500	1VR2181V0K1009650
BC1500	1VR2181V4K1009554	BC1500	1VR2181V2K1009603	BC1500	1VR2181V2K1009651
BC1500	1VR2161V0K1009555	BC1500	1VR2181V4K1009604	BC1500	1VR2181V4K1009652
BC1500	1VR2181V8K1009556	BC1500	1VR2181V6K1009605	BC1500	1VR2181V6K1009653
BC1500	1VR2181VXK1009557	BC1500	1VR2181V8K1009606	BC1500	1VR2181V8K1009654
BC1500	1VR2181V1K1009558	BC1500	1VR2181VXK1009607	BC1500	1VR2181V3K1009657
BC1500	1VR2181V3K1009559	BC1500	1VR2181V1K1009608	BC1500	1VR2181V5K1009658
BC1500	1VR2181VXK1009560	BC1500	1VR2181V3K1009609	BC1500	1VR2181V7K1009659
BC1500	1VR2181V1K1009561	BC1500	1VR2181VXK1009610	BC1500	1VR2181V3K1009660
BC1500	1VR2181V3K1009562	BC1500	1VR2181V1K1009611	BC1500	1VR2181V9K1009663
BC1500	1VR2181V5K1009563	BC1500	1VR2181V3K1009612	BC1500	1VR2161V5K1009664
BC1500	1VR2181V7K1009564	BC1500	1VR2181V5K1009613	BC1500	1VR2181V2K1009665
BC1500	1VR2181V9K1009565	BC1500	1VR2181V7K1009614	BC1500	1VR2181V4K1009666
BC1500	1VR2181V0K1009566	BC1500	1VR2181V9K1009615	BC1500	1VR2181V6K1009667
BC1500	1VR2181V2K1009567	BC1500	1VR2181V4K1009618	BC1500	1VR2181V8K1009668
BC1500	1VR2181V4K1009568	BC1500	1VR2181V6K1009619	BC1500	1VR2181VXK1009669
BC1500	1VR2181V6K1009569	BC1500	1VR2181V2K1009620	BC1500	1VR2161V2K1009671
BC1500	1VR2181V2K1009570	BC1500	1VR2181V4K1009621	BC1500	1VR2181VXK1009672

**AFFECTED MACHINES - IK01-3922**

MODEL	VIN	MODEL	VIN	MODEL	VIN
BC1500	1VR2181V1K1009673	BC1500	1VR2181VXL1009723	BC1500	1VR2181V1L1009772
BC1500	1VR2181V3K1009674	BC1500	1VR2181V1L1009724	BC1500	1VR2181V3L1009773
BC1500	1VR2181V5K1009675	BC1500	1VR2181V3L1009725	BC1500	1VR2181V7L1009775
BC1500	1VR2181V7K1009676	BC1500	1VR2181V5L1009726	BC1500	1VR2181V9L1009776
BC1500	1VR2181V9K1009677	BC1500	1VR2181V7L1009727	BC1500	1VR2181V0L1009777
BC1500	1VR2181V0K1009678	BC1500	1VR2181V9L1009728	BC1500	1VR2181V2L1009778
BC1500	1VR2181V9K1009680	BC1500	1VR2181V0L1009729	BC1500	1VR2181V0L1009780
BC1500	1VR2181V0K1009681	BC1500	1VR2181V7L1009730	BC1500	1VR2181V2L1009781
BC1500	1VR2181V2K1009682	BC1500	1VR2181V9L1009731	BC1500	1VR2181V4L1009782
BC1500	1VR2181V4K1009683	BC1500	1VR2181V4L1009734	BC1500	1VR2181V8L1009784
BC1500	1VR2181V6K1009684	BC1500	1VR2181V6L1009735	BC1500	1VR2181VXL1009785
BC1500	1VR2181V8K1009685	BC1500	1VR2181V8L1009736	BC1500	1VR2181V1L1009786
BC1500	1VR2181V3K1009688	BC1500	1VR2181VXL1009737	BC1500	1VR2181V3L1009787
BC1500	1VR2181V5K1009689	BC1500	1VR2181V3L1009739	BC1500	1VR2181V5L1009788
BC1500	1VR2181V1K1009690	BC1500	1VR2181VXL1009740	BC1500	1VR2181V3L1009790
BC1500	1VR2181V3K1009691	BC1500	1VR2181V1L1009741	BC1500	1VR2181V5L1009791
BC1500	1VR2181V5K1009692	BC1500	1VR2181V3L1009742	BC1500	1VR2181V7L1009792
BC1500	1VR2181V7K1009693	BC1500	1VR2181V5L1009743	BC1500	1VR2181V9L1009793
BC1500	1VR2181V9K1009694	BC1500	1VR2181V9L1009745	BC1500	1VR2181V0L1009794
BC1500	1VR2181V0K1009695	BC1500	1VR2181V0L1009746	BC1500	1VR2181V2L1009795
BC1500	1VR2181V2K1009696	BC1500	1VR2181V2L1009747	BC1500	1VR2181V6L1009797
BC1500	1VR2181V4K1009697	BC1500	1VR2181V4L1009748	BC1500	1VR2181VXL1009799
BC1500	1VR2181V6K1009698	BC1500	1VR2181V6L1009749	BC1500	1VR2181V2L1009800
BC1500	1VR2181V8K1009699	BC1500	1VR2181V2L1009750	BC1500	1VR2181V4L1009801
BC1500	1VR2181V0K1009700	BC1500	1VR2181V4L1009751	BC1500	1VR2181V6L1009802
BC1500	1VR2181V4K1009702	BC1500	1VR2181V6L1009752	BC1500	1VR2181V8L1009803
BC1500	1VR2181V6K1009703	BC1500	1VR2181V8L1009753	BC1500	1VR2181VXL1009804
BC1500	1VR2181V8K1009704	BC1500	1VR2181V1L1009755	BC1500	1VR2181V1L1009805
BC1500	1VR2181V1K1009706	BC1500	1VR2181V3L1009756	BC1500	1VR2181V3L1009806
BC1500	1VR2181V3K1009707	BC1500	1VR2181V5L1009757	BC1500	1VR2181V5L1009807
BC1500	1VR2181V7K1009709	BC1500	1VR2181V7L1009758	BC1500	1VR2181V7L1009808
BC1500	1VR2181V3K1009710	BC1500	1VR2181V9L1009759	BC1500	1VR2181V9L1009809
BC1500	1VR2181V7K1009712	BC1500	1VR2181V5L1009760	BC1500	1VR2181V5L1009810
BC1500	1VR2181V9K1009713	BC1500	1VR2181V7L1009761	BC1500	1VR2181V7L1009811
BC1500	1VR2181V0K1009714	BC1500	1VR2181V9L1009762	BC1500	1VR2181V9L1009812
BC1500	1VR2181V2K1009715	BC1500	1VR2181V2L1009764	BC1500	1VR2181V0L1009813
BC1500	1VR2181V4K1009716	BC1500	1VR2181V4L1009765	BC1500	1VR2181V2L1009814
BC1500	1VR2181V6K1009717	BC1500	1VR2181V6L1009766	BC1500	1VR2181V6L1009816
BC1500	1VR2161V2K1009718	BC1500	1VR2181V8L1009767	BC1500	1VR2181V1L1009819
BC1500	1VR2161V4K1009719	BC1500	1VR2181VXL1009768	BC1500	1VR2181V8L1009820
BC1500	1VR2181V4L1009720	BC1500	1VR2181V1L1009769	BC1500	1VR2181VXL1009821
BC1500	1VR2181V6L1009721	BC1500	1VR2181V8L1009770	BC1500	1VR2181V1L1009822
BC1500	1VR2181V8L1009722	BC1500	1VR2181VXL1009771	BC1500	1VR2181V3L1009823

**AFFECTED MACHINES - IK01-3922**

MODEL	VIN	MODEL	VIN	MODEL	VIN
BC1500	1VR2181V5L1009824	BC1500	1VR2181V0L1009875	BC1500	1VR2181VXL1009933
BC1500	1VR2181V7L1009825	BC1500	1VR2181V2L1009876	BC1500	1VR2181V1L1009934
BC1500	1VR2181V9L1009826	BC1500	1VR2181V4L1009877	BC1500	1VR2181V3L1009935
BC1500	1VR2181V0L1009827	BC1500	1VR2161V9L1009880	BC1500	1VR2181V5L1009936
BC1500	1VR2181V4L1009829	BC1500	1VR2181V6L1009881	BC1500	1VR2181V7L1009937
BC1500	1VR2181V0L1009830	BC1500	1VR2181V8L1009882	BC1500	1VR2181V9L1009938
BC1500	1VR2181V2L1009831	BC1500	1VR2181VXL1009883	BC1500	1VR2181V0L1009939
BC1500	1VR2181V4L1009832	BC1500	1VR2181V1L1009884	BC1500	1VR2181V9L1009941
BC1500	1VR2181V6L1009833	BC1500	1VR2181V3L1009885	BC1500	1VR2181V0L1009942
BC1500	1VR2181V8L1009834	BC1500	1VR2181V5L1009886	BC1500	1VR2181V2L1009943
BC1500	1VR2181VXL1009835	BC1500	1VR2181V7L1009887	BC1500	1VR2181V4L1009944
BC1500	1VR2181V1L1009836	BC1500	1VR2181V9L1009888	BC1500	1VR2181V6L1009945
BC1500	1VR2181V3L1009837	BC1500	1VR2181V0L1009889	BC1500	1VR2181V8L1009946
BC1500	1VR2181V5L1009841	BC1500	1VR2181V7L1009890	BC1500	1VR2181VXL1009947
BC1500	1VR2181V7L1009842	BC1500	1VR2181V9L1009891	BC1500	1VR2181V1L1009948
BC1500	1VR2181V9L1009843	BC1500	1VR2181V0L1009892	BC1500	1VR2181V3L1009949
BC1500	1VR2181V0L1009844	BC1500	1VR2181V2L1009893	BC1500	1VR2181V1L1009951
BC1500	1VR2181V2L1009845	BC1500	1VR2181V4L1009894	BC1500	1VR2181V7L1009954
BC1500	1VR2181V4L1009846	BC1500	1VR2181V6L1009895	BC1500	1VR2181V9L1009955
BC1500	1VR2181V6L1009847	BC1500	1VR2161V6L1009898	BC1500	1VR2161V5L1009956
BC1500	1VR2181V8L1009848	BC1500	1VR2161V8L1009899	BC1500	1VR2181V2L1009957
BC1500	1VR2181VXL1009849	BC1500	1VR2181V6L1009900	BC1500	1VR2181V4L1009958
BC1500	1VR2181V6L1009850	BC1500	1VR2181V8L1009901	BC1500	1VR2181V6L1009959
BC1500	1VR2181V8L1009851	BC1500	1VR2181VXL1009902	BC1500	1VR2181V2L1009960
BC1500	1VR2181VXL1009852	BC1500	1VR2181V3L1009904	BC1500	1VR2181V4L1009961
BC1500	1VR2181V1L1009853	BC1500	1VR2181V5L1009905	BC1500	1VR2181V6L1009962
BC1500	1VR2181V5L1009855	BC1500	1VR2181V7L1009906	BC1500	1VR2181V8L1009963
BC1500	1VR2181V7L1009856	BC1500	1VR2181V9L1009907	BC1500	1VR2161V4L1009964
BC1500	1VR2181V9L1009857	BC1500	1VR2181V2L1009912	BC1500	1VR2181V3L1009966
BC1500	1VR2181V0L1009858	BC1500	1VR2181V4L1009913	BC1500	1VR2181V7L1009968
BC1500	1VR2181V2L1009859	BC1500	1VR2181V6L1009914	BC1500	1VR2181V9L1009969
BC1500	1VR2181V9L1009860	BC1500	1VR2181V8L1009915	BC1500	1VR2181V5L1009970
BC1500	1VR2181V0L1009861	BC1500	1VR2181V1L1009917	BC1500	1VR2181V7L1009971
BC1500	1VR2181V2L1009862	BC1500	1VR2181V3L1009918	BC1500	1VR2181V9L1009972
BC1500	1VR2181V4L1009863	BC1500	1VR2181V5L1009919	BC1500	1VR2181V0L1009973
BC1500	1VR2181V1L1009867	BC1500	1VR2181V1L1009920	BC1500	1VR2161V7L1009974
BC1500	1VR2181V3L1009868	BC1500	1VR2181V5L1009922	BC1500	1VR2181V4L1009975
BC1500	1VR2181V5L1009869	BC1500	1VR2181V7L1009923	BC1500	1VR2181V6L1009976
BC1500	1VR2181V1L1009870	BC1500	1VR2181V2L1009926	BC1500	1VR2181V8L1009977
BC1500	1VR2181V3L1009871	BC1500	1VR2181V4L1009927	BC1500	1VR2181VXL1009978
BC1500	1VR2181V5L1009872	BC1500	1VR2181V8L1009929	BC1500	1VR2181V1L1009979
BC1500	1VR2181V7L1009873	BC1500	1VR2181V4L1009930	BC1500	1VR2181V8L1009980
BC1500	1VR2181V9L1009874	BC1500	1VR2181V8L1009932	BC1500	1VR2181VXL1009981



**AFFECTED MACHINES - IK01-3922**

MODEL	VIN	MODEL	VIN	MODEL	VIN
BC1500	1VR2181V1L1009982	BC1500	1VR2181V9L1011009	BC1500	1VR2181VXL1011052
BC1500	1VR2181V3L1009983	BC1500	1VR2181V5L1011010	BC1500	1VR2181V1L1011053
BC1500	1VR2181V5L1009984	BC1500	1VR2181V7L1011011	BC1500	1VR2181V3L1011054
BC1500	1VR2161V1L1009985	BC1500	1VR2161V3L1011012	BC1500	1VR2181V5L1011055
BC1500	1VR2181V9L1009986	BC1500	1VR2181V0L1011013		
BC1500	1VR2181V0L1009987	BC1500	1VR2181V2L1011014		
BC1500	1VR2181V2L1009988	BC1500	1VR2181V4L1011015		
BC1500	1VR2181V4L1009989	BC1500	1VR2181V6L1011016		
BC1500	1VR2181V0L1009990	BC1500	1VR2181V8L1011017		
BC1500	1VR2181V2L1009991	BC1500	1VR2181VXL1011018		
BC1500	1VR2181V4L1009992	BC1500	1VR2181V1L1011019		
BC1500	1VR2181V6L1009993	BC1500	1VR2181V8L1011020		
BC1500	1VR2181V8L1009994	BC1500	1VR2181VXL1011021		
BC1500	1VR2181V1L1009996	BC1500	1VR2161V6L1011022		
BC1500	1VR2181V3L1009997	BC1500	1VR2181V3L1011023		
BC1500	1VR2181V5L1009998	BC1500	1VR2181V5L1011024		
BC1500	1VR2181V7L1009999	BC1500	1VR2181V7L1011025		
BC1500	1VR2181V8L1010000	BC1500	1VR2181V9L1011026		
BC1500	1VR2181VXL1010001	BC1500	1VR2181V0L1011027		
BC1500	1VR2181V1L1010002	BC1500	1VR2181V2L1011028		
BC1500	1VR2181V3L1010003	BC1500	1VR2181V4L1011029		
BC1500	1VR2181V7L1010005	BC1500	1VR2181V0L1011030		
BC1500	1VR2181V9L1010006	BC1500	1VR2181V2L1011031		
BC1500	1VR2181V0L1010007	BC1500	1VR2161V9L1011032		
BC1500	1VR2181V2L1010008	BC1500	1VR2161V0L1011033		
BC1500	1VR2181V4L1010009	BC1500	1VR2181V8L1011034		
BC1500	1VR2181V0L1010010	BC1500	1VR2181VXL1011035		
BC1500	1VR2181V4L1010012	BC1500	1VR2181V1L1011036		
BC1500	1VR2181V6L1010013	BC1500	1VR2181V3L1011037		
BC1500	1VR2181V8L1010014	BC1500	1VR2181V5L1011038		
BC1500	1VR2181V1L1010016	BC1500	1VR2181V7L1011039		
BC1500	1VR2181V3L1010017	BC1500	1VR2181V3L1011040		
BC1500	1VR2181V5L1010018	BC1500	1VR2181V5L1011041		
BC1500	1VR2181V7L1010019	BC1500	1VR2181V7L1011042		
BC1500	1VR2181V3L1010020	BC1500	1VR2181V9L1011043		
BC1500	1VR2161V9L1011001	BC1500	1VR2161V5L1011044		
BC1500	1VR2181V6L1011002	BC1500	1VR2181V2L1011045		
BC1500	1VR2181V8L1011003	BC1500	1VR2181V4L1011046		
BC1500	1VR2181VXL1011004	BC1500	1VR2181V6L1011047		
BC1500	1VR2181V1L1011005	BC1500	1VR2181V8L1011048		
BC1500	1VR2181V3L1011006	BC1500	1VR2181VXL1011049		
BC1500	1VR2181V5L1011007	BC1500	1VR2181V6L1011050		
BC1500	1VR2181V7L1011008	BC1500	1VR2181V8L1011051		

**AFFECTED MACHINES - IK03-3922**

Model	VIN	Model	VIN	Model	VIN
BC1500	1VR2161V381001426	BC1500	1VR2161V2J1008972	BC1500	1VR2181VXL1009754
BC1500	1VR2161V281001577	BC1500	1VR2181VXJ1008973	BC1500	1VR2181V0L1009763
BC1500	1VR2161V591002059	BC1500	1VR2181V0J1008996	BC1500	1VR2181V5L1009774
BC1500	1VR2161V391002285	BC1500	1VR2161V5J1009002	BC1500	1VR2181V6L1009783
BC1500	1VR2161V8A1002464	BC1500	1VR2181V9J1009046	BC1500	1VR2181V7L1009789
BC1500	1VR2161V5A1002521	BC1500	1VR2181V3J1009060	BC1500	1VR2181V4L1009796
BC1500	1VR2161V0B1002556	BC1500	1VR2161VXJ1009089	BC1500	1VR2181V4L1009815
BC1500	1VR2161V5C1002831	BC1500	1VR2161V8J1009091	BC1500	1VR2161V2L1009817
BC1500	1VR2161V1C1003085	BC1500	1VR2161V1J1009093	BC1500	1VR2181VXL1009818
BC1500	1VR2161V1C1003152	BC1500	1VR2181V8J1009099	BC1500	1VR2181V2L1009828
BC1500	1VR2161V7E1005748	BC1500	1VR2161V9J1009102	BC1500	1VR2181V5L1009838
BC1500	1VR2161V8E1005838	BC1500	1VR2161V4J1009105	BC1500	1VR2161V8L1009840
BC1500	1VR2161V8E1005886	BC1500	1VR2181V6J1009134	BC1500	1VR2181V6L1009864
BC1500	1VR2161V2E1005964	BC1500	1VR2181V2J1009180	BC1500	1VR2161V2L1009879
BC1500	1VR2161V7F1006402	BC1500	1VR2181V7J1009191	BC1500	1VR2181V8L1009896
BC1500	1VR2161V3F1006414	BC1500	1VR2181V3J1009205	BC1500	1VR2181V1L1009903
BC1500	1VR2161V1F1006430	BC1500	1VR2181V0J1009226	BC1500	1VR2181V2L1009909
BC1500	1VR2161VXF1006443	BC1500	1VR2181V2J1009227	BC1500	1VR2181V9L1009910
BC1500	1VR2161V8G1006796	BC1500	1VR2161V7K1009259	BC1500	1VR2181V0L1009911
BC1500	1VR2181VXG1008013	BC1500	1VR2181V9K1009288	BC1500	1VR2181VXL1009916
BC1500	1VR2161V2G1008284	BC1500	1VR2181V1K1009334	BC1500	1VR2181V3L1009921
BC1500	1VR2181VXH1008496	BC1500	1VR2181V8K1009380	BC1500	1VR2181V6L1009928
BC1500	1VR2181V7H1008519	BC1500	1VR2161VXK1009451	BC1500	1VR2181V6L1009931
BC1500	1VR2161VXH1008521	BC1500	1VR2161V2K1009508	BC1500	1VR2161V1L1009940
BC1500	1VR2161V6H1008550	BC1500	1VR2161V4K1009512	BC1500	1VR2181VXL1009950
BC1500	1VR2181V1H1008564	BC1500	1VR2161V5K1009535	BC1500	1VR2181V3L1009952
BC1500	1VR2181V3H1008601	BC1500	1VR2161V7K1009553	BC1500	1VR2181V5L1009953
BC1500	1VR2181V9H1008618	BC1500	1VR2181V7K1009600	BC1500	1VR2181V1L1009965
BC1500	1VR2161VXH1008633	BC1500	1VR2161V3K1009632	BC1500	1VR2181V5L1009967
BC1500	1VR2181V6H1008639	BC1500	1VR2161V9K1009635	BC1500	1VR2161V4L1009995
BC1500	1VR2181V2H1008640	BC1500	1VR2161V4K1009655	BC1500	1VR2181V5L1010004
BC1500	1VR2161V9H1008722	BC1500	1VR2161V6K1009656	BC1500	1VR2161V7L1010011
BC1500	1VR2161V3H1008750	BC1500	1VR2181V5K1009661		
BC1500	1VR2161V9J1008774	BC1500	1VR2181V7K1009662		
BC1500	1VR2181V8J1008793	BC1500	1VR2161V7K1009679		
BC1500	1VR2181V1J1008795	BC1500	1VR2161V4K1009686		
BC1500	1VR2181V9J1008799	BC1500	1VR2161V6K1009687		
BC1500	1VR2181V4J1008855	BC1500	1VR2161V7K1009701		
BC1500	1VR2181V3J1008863	BC1500	1VR2181VXK1009705		
BC1500	1VR2181V7J1008879	BC1500	1VR2161V5L1009732		
BC1500	1VR2181V8J1008891	BC1500	1VR2181V2L1009733		
BC1500	1VR2181V9J1008902	BC1500	1VR2161V6L1009738		
BC1500	1VR2181V7J1008915	BC1500	1VR2181V7L1009744		



**PURPOSE:** Specific wheels (steel rim) with bolt pattern 8 on 6 1/2" (165.1 mm) circle to be used with 5/8" studs provided by a supplier:

- have an incorrect lug nut contact area causing wheel lug nuts to loosen; and/or
- can develop possible cracks causing the tire to loose air pressure.

Both conditions may increase the risk of wheel loss and the risk of a crash. Death or serious injury is possible. Property damage may also occur. This kit provides the necessary parts and instructions to replace the wheel/tire assembly, and a new safety sign, and provide a supplemental manual.

**SPECIAL TOOLS AND CONDITIONS:**

- None



**WARNING:** Raised load can shift or fall. Death or serious injury could be possible if struck or crushed by falling load. Never allow anyone under a raised load unless load is securely supported to prevent it from shifting or falling.

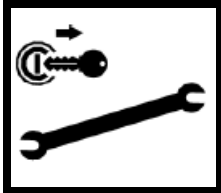

**WARNING:** Failure to use shutdown procedure can result in unexpected hazard(s). Death or serious injury could result due to entanglement, crushing, cutting, or other hazardous contact. Follow Shutdown Procedure after operating, before performing any service or maintenance, and before transporting.



## BC1500 SHUTDOWN PROCEDURE

### STOPPING THE MACHINE

**NOTICE:** For your safety and safety of others, use the shutdown procedure before working on the machine for any reason, including servicing, cleaning, unclogging, inspecting, or transporting the chipper.

A variation of this procedure may be used if so instructed within this manual or if an emergency requires it.

**Step 1:** Return *Upper Feed Control Bar* to center STOP position.

**Step 2:** Place *Throttle Switch* in LOW PRM.

**NOTICE:** Whenever practical and consistent with good safety practice idle engine without load for a few minutes before shutting it off. This allows engine temperatures to decrease and equalize, which will increase engine life.

**Step 3:** Wait for cutter drum to slow.

**Step 4:** Place *Clutch / Throttle Lever* in the DISENGAGED/LOW RPM position.

**Step 5:** If so equipped, shut of remote control if in use.

**Step 6:** Shut off engine and remove key.

**Step 7:** Wait for cutter drum and belt to stop.

**NOTICE:** Cutter drum rotation can be checked by looking at the end of the shaft (1) on the left side of the cutter drum housing.

**Step 8:** Close and latch feed table.

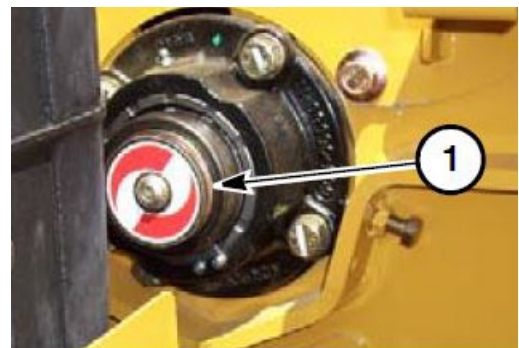
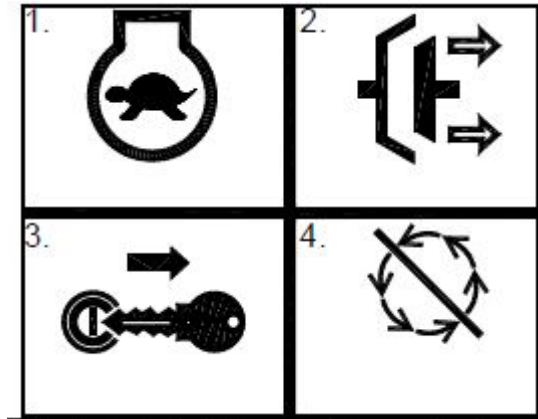

## PROCEDURE: WHEELS, AXLES, AND SUSPENSION MAINTENANCE

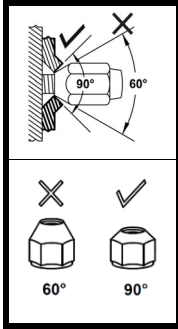

**WARNING:** Incompatible lug nuts may loosen and cause wheel loss.

Use only 5/8-18 lug nuts with a 90° conicle taper.

**NOTICE:** Improper or mismatched lug nuts and wheels can cause wheel loss leading to a crash. The conical taper of the lug nuts must properly engage the wheel lug nut seats.

The wheels and axle hubs on this trailer use special 5/8"-18 lug nuts with a 90° conical taper.

Never use incompatible lug nuts, such as those with a 60° taper or a flat face.

Never use wheels intended for 9/16" wheel lugs.

Never use wheels that do not utilize a 90° conical lug nut seat taper.

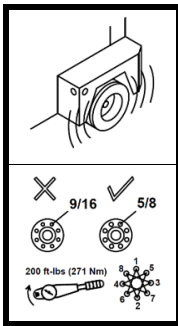

**WARNING:** Incompatible wheels or loose lug nuts can cause wheel loss and machine damage.

Use only wheels that are compatible with 5/8 lug studs and 90° conical nuts. Check lug nut torque regularly.

Properly tighten lug nuts in a star pattern using only hand tools. **DO NOT** use impact wrenches which can damage the lug nuts, lug nut seats, and hub studs. Torque and recheck every 500 miles (800 km).

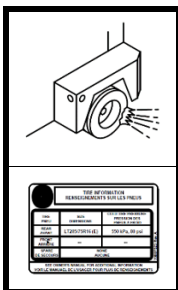

**WARNING:** Improper tire pressure can cause a blowout.

Set cold tire pressure according to tire placard.  
Check pressure monthly.

**NOTICE:** Under-inflation causes tire damage and can lead to a blowout.

Set the tire air pressure to the value listed on the machine's tire placard, NOT the pressure printed on the sidewall of the tire. Recheck monthly. Tires normally lose 1–2 psi (6.9–13.8 kPa) per month.

Tire pressure can also drop if the temperature outside has dropped significantly, so check more often in cold weather.

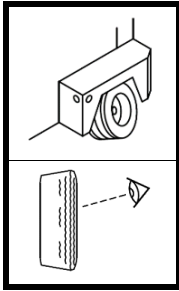

**WARNING:** Worn or damaged suspension can cause premature tire wear and machine damage.

Uneven wear on tires can be an indication of worn suspension or poor alignment.

**NOTICE:** Axle or suspension damage can cause pre-mature tire wear and tire failure, or axle failure.

Have your trailer checked if you suspect misalignment, if your tires have suffered any type of impact, or if you observe uneven tire wear.



Unless indicated, new parts from kit have callouts with numbers.  
Callouts with letters indicate existing parts or general items.



## PROCEDURE: WHEEL AND TIRE ASSEMBLY 17.5 IK01

- Step 1: Using a suitable lifting device capable of lifting approximately 10,000 lb (4550 kg), raise machine off ground to allow adequate room to remove tire.
- Step 2: Place suitable blocking under trailer frame and remove lifting device.
- Step 3: Remove and discard eight wheel nuts, and wheel from each side of machine. Weight of each wheel is approximately 91 lb (42 kg)
- Step 4: Torch cut wheels across lug nut area.
- Step 5: Take a photo(s) of destroyed wheels and attach to campaign warranty claim.
- Step 6: Discard wheel nuts so they can no longer be used or sold for any purpose.
- Step 7: The removed used tires may be retained in your **used** tire inventory or disposed of. Cost of tire removal is included in labor hours.
- Step 8: Attach two new wheels (2) on axle using 16 wheel nuts (1). Weight of each wheel is approximately 91 lb (42 kg).
- Step 9: Slide retainer ring (3) on each side of axle.
- Step 10: Torque wheel nuts in a star pattern to 200 ft-lb (28 kg).
- Step 11: Check tire pressure to be at 85 psi (5.9 bar).

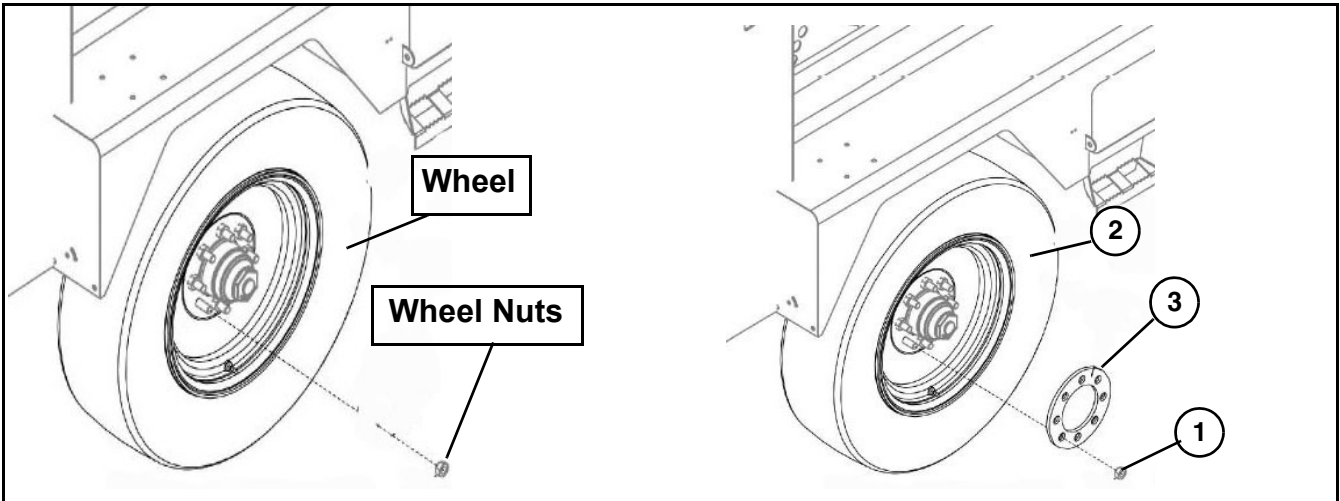

- Step 12: Attach one new wheel and tire warning decal (4) on each side of machine. Attach one new tire information decal (5) on left side of machine.

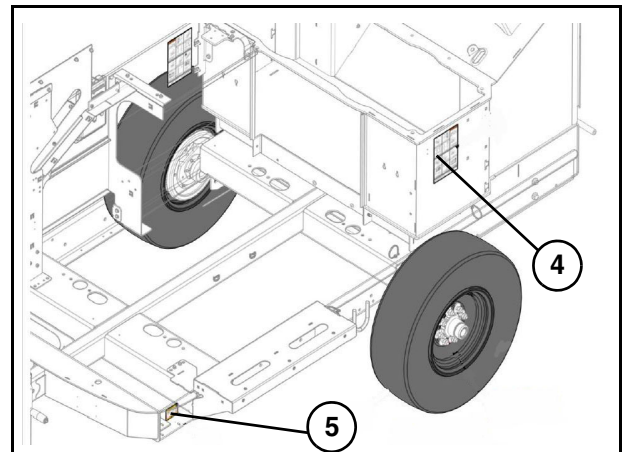

## PROCEDURE: WHEEL AND TIRE ASSEMBLY IK02

- Step 1:** Using a suitable lifting device capable of lifting approximately 10,000 lb (4550 kg), raise machine off ground to allow adequate room to remove tire.
- Step 2:** Place suitable blocking under trailer frame and remove lifting device.
- Step 3:** Remove and discard eight wheel nuts, and wheel from each side of machine. Weight of each wheel is approximately 91 lb (42 kg)
- Step 4:** Torch cut wheels across lug nut area.
- Step 5:** Take a photo(s) of destroyed wheels and attach to campaign warranty claim.
- Step 6:** Discard wheel nuts so they can no longer be used or sold for any purpose.
- Step 7:** The removed used tires may be retained in your used tire inventory or disposed of. Cost of tire removal is included in labor hours.
- Step 8:** Attach two new wheels (2) on axle using 16 wheel nuts (1). Weight of each wheel is approximately 91 lb (42 kg).
- Step 9:** Slide retainer ring (3) on each side of axle.
- Step 10:** Torque wheel nuts in a star pattern to 200 ft-lb (28 kg).
- Step 11:** Check tire pressure to be at 85 psi (5.9 bar).

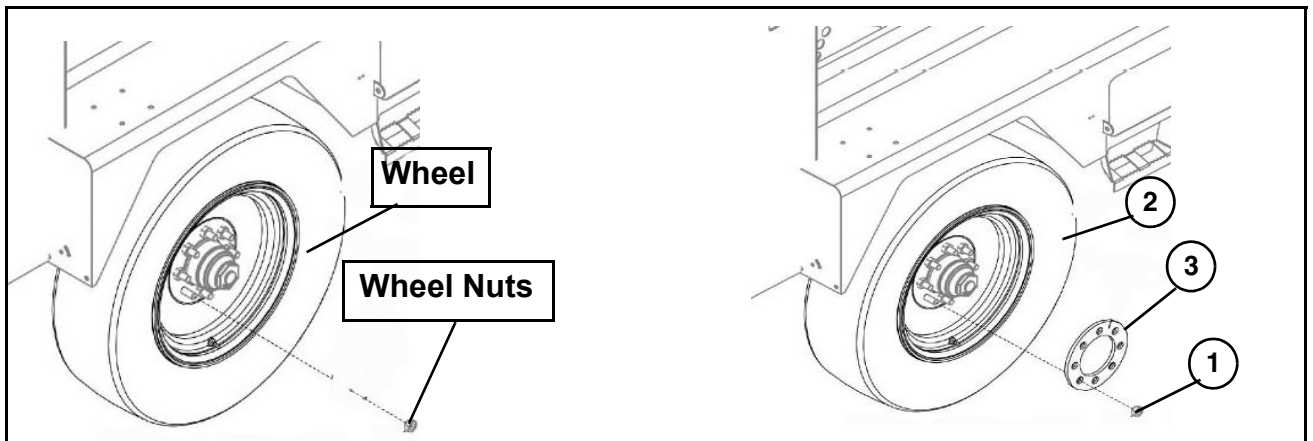

- Step 12:** Attach one new wheel and tire warning decal (6) on each side of machine. Attach one new tire information decal (5) on left side of machine.

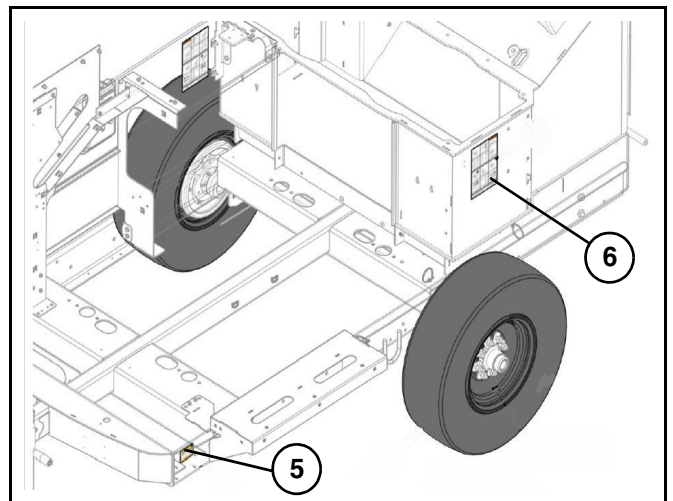

# PROCEDURE: WHEEL AND TIRE ASSEMBLY 17.5 IK03

Step 1: Attach one new wheel and tire warning decal (4) on each side of machine. Attach one new tire information decal (5) on left side of machine.

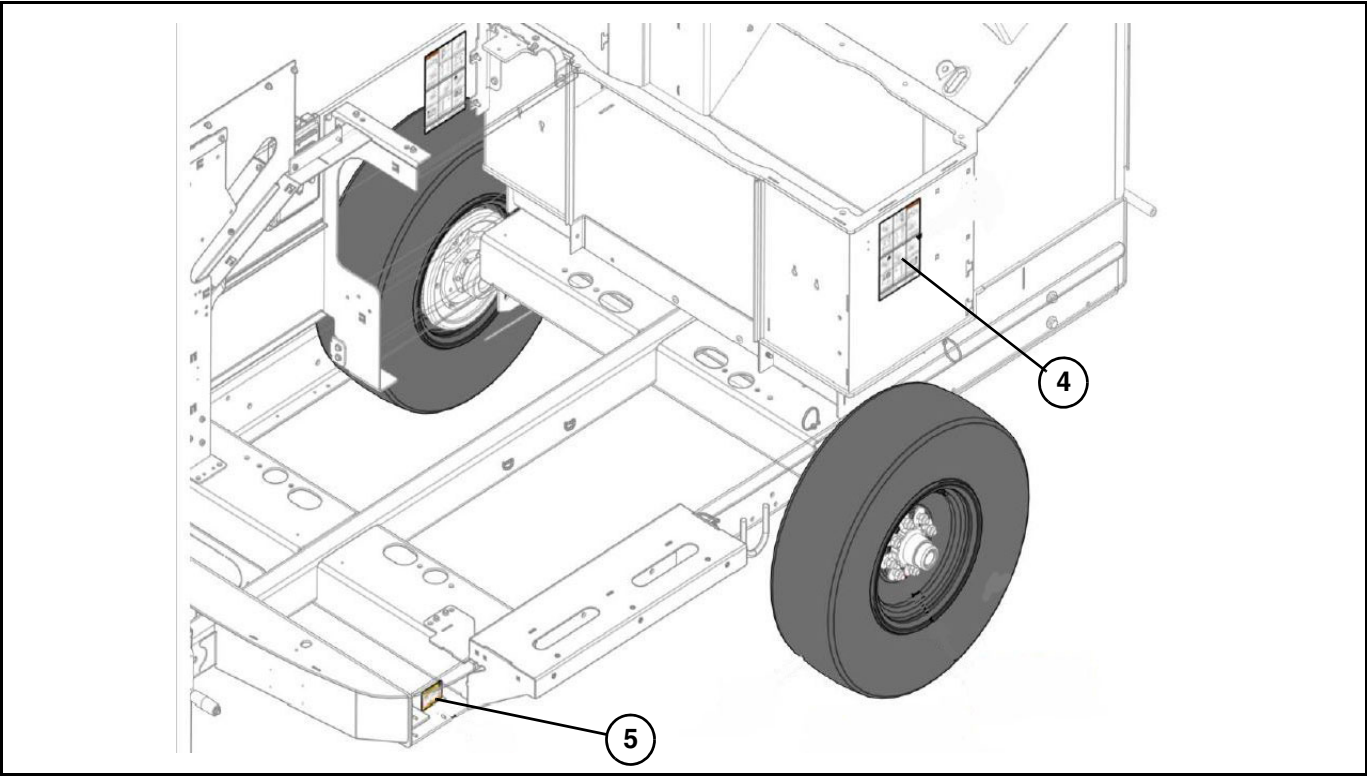

**PROCEDURE: WHEEL AND TIRE ASSEMBLY 17.5 IK04**

**Step 1:** Attach one new wheel and tire warning decal (6) on each side of machine. Attach one new tire information decal (5) on left side of machine.

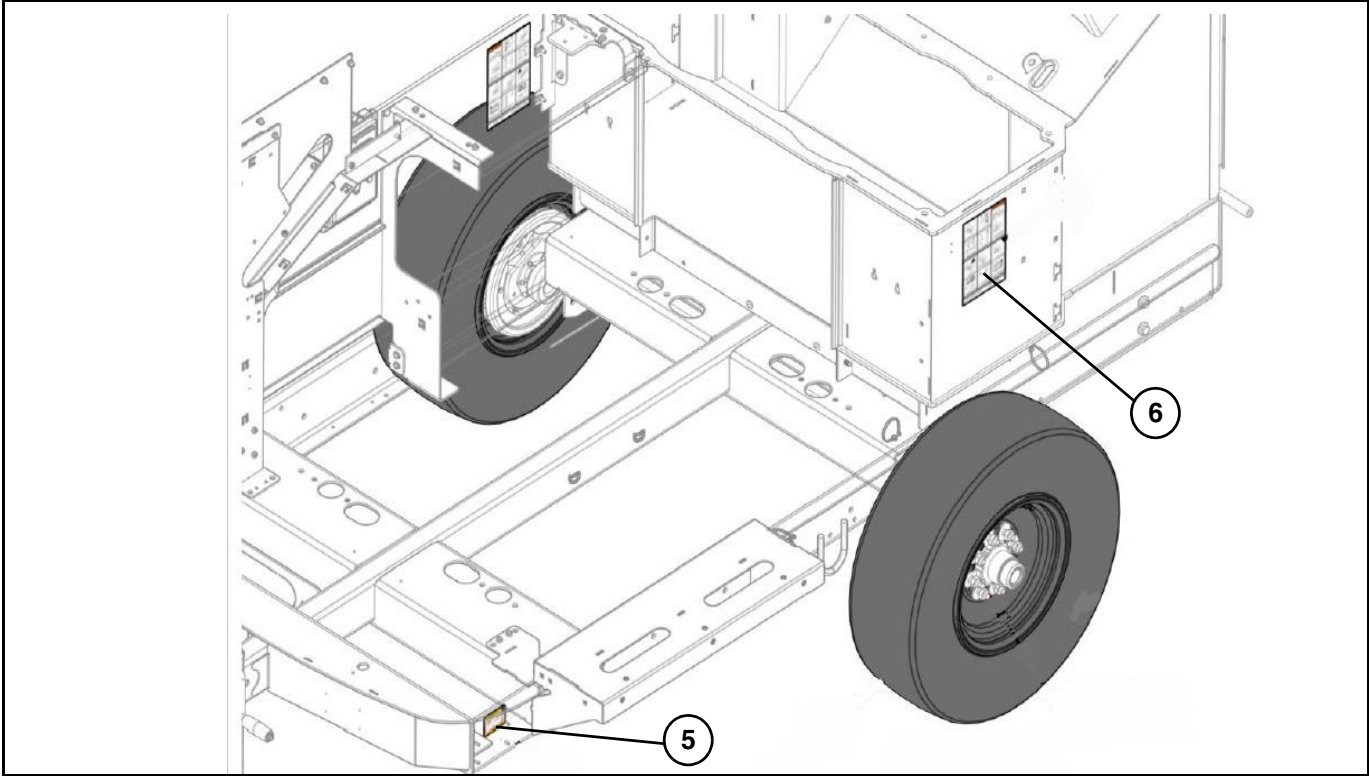



**Figure 1**

UNIT OWNER COPY:  
Insert into Parts Manual  
for future reference

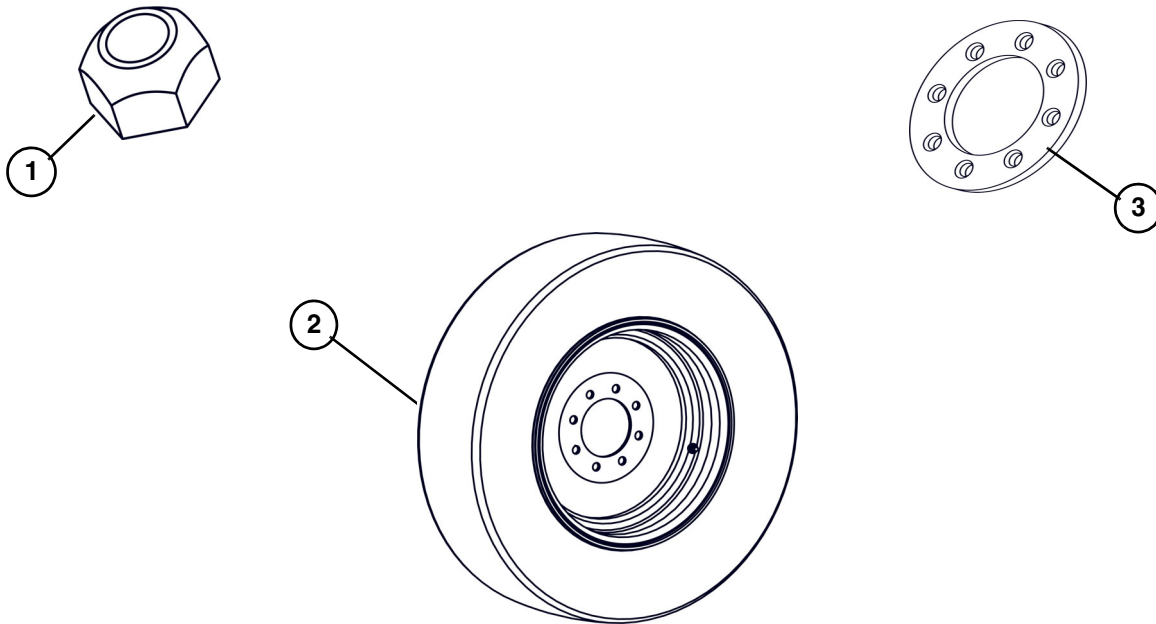

**FIGURE 1 Parts List**

<u>REF. NO.</u>	<u>PART NO.</u>	<u>DESCRIPTION</u>	<u>IK01 QTY.</u>	<u>IK02 QTY.</u>	<u>IK03 QTY.</u>	<u>IK04 QTY.</u>
1	116621009	WHEEL NUT 5/8in 18 CONE 90°	16	16	-	-
2	163713905	HEAVY DUTY - WHEEL ASSY - 235/75R17.5 H/J; 5/8 S	2	2	-	-
3	215490049	CLAMP RING	2	2	-	-
		Kit includes all items in Figure 1 Parts List.				

**Figure 2**

UNIT OWNER COPY:  
Insert into Parts Manual  
for future reference



**TIRE INFORMATION**  
**RENSEIGNEMENTS SUR LES PNEUS**

TIRE PNEU	SIZE DIMENSIONS	COLD TIRE PRESSURE PRESSION DES PNEUS A FROID
REAR AVANT	235/75R17.5 H/J	586 kPa, 85 psi
FRONT ARRIÈRE	—	—
SPARE DE SECOURS	NONE AUCUNE	

7000J032 Rev A

SEE OWNER'S MANUAL FOR ADDITIONAL INFORMATION  
VOIR LE MANUEL DE L'USAGER POUR PLUS DE RENSEIGNEMENTS

▲ **WARNING**

7000J038 Rev A



Wheel loss, tire blowout, and loss of vehicle control can occur, causing death or serious injury.

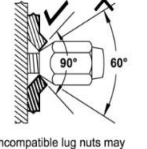

Incompatible lug nuts may loosen and cause wheel loss.



Incompatible wheels or loose lug nuts can cause wheel loss.

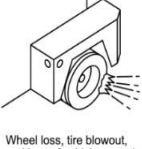

Wheel loss, tire blowout, and loss of vehicle control can occur, causing death or serious injury.

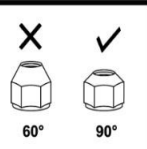

Use only 5/8-18 nuts with a 90° conical taper.

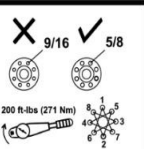

Use only proper wheels. Check torque regularly.

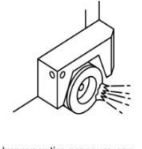

Improper tire pressure can cause a blowout.



Worn or damaged suspension can cause premature tire wear and machine damage.



Avoid overloading or excess speed.

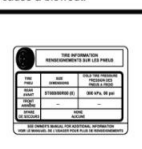

Set cold tire pressure according to tire placard, NOT maximum pressure printed on sidewall.

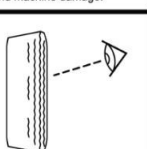

Uneven wear on tires is an indication of worn suspension or poor alignment.

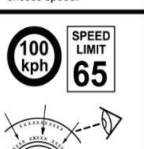

Always follow manufacturer's load and speed ratings.



ALWAYS use Vermeer authorized wheels, lug nuts, tires, and suspension components.

7000J038 Rev A



























**FIGURE 2 Parts List**

REF. NO.	PART NO.	DESCRIPTION	IK01 QTY.	IK02 QTY.	IK03 QTY.	IK04 QTY.
4	7000J038	DECAL-WARNING, WHEEL & TIRE	2	-	2	-
5	7000J032	DECAL- TIRE INFORMATION	1	1	1	1
6	7000J038	Decal – Warning, Wheel & Tire	-	2	-	2
		Kit includes all items in Figure 2 Parts List.				

**Figure 3**

UNIT OWNER COPY:  
Insert into Parts Manual  
for future reference

①



EQUIPPED TO  
DO MORE.®

## Brush Chipper Wheel/Tire Supplemental Operator's and Maintenance Manual

MODEL	KIT
BC1000XL	IK003940
BC1200XL	IK003941
BC1500	IK003922
BC1800XL	IK003942
AX19	IK003939

Brush Chipper Wheel/Tire\_Supp1\_00  
Order No. 105400FQ9  
Cabled Assembly Order No. 163802006

**Environmental Products**

**FIGURE 3 Parts List**

<u>REF. NO.</u>	<u>PART NO.</u>	<u>DESCRIPTION</u>	<u>IK01 QTY.</u>	<u>IK02 QTY.</u>	<u>IK03 QTY.</u>	<u>IK04 QTY.</u>
1	163802006	BRUSH CHIPPER WHL/TIR SUPPLEMENTAL MANUAL CABLED	1	1	1	1
	105400FQ9	BRUSH CHIPPER WHEEL/TIRE SUPPLEMENTAL MANUAL	1	1	1	1
		Kit includes all items in Figure 3 Parts List.				