

IMPORTANT UPDATE

TECHNICAL INSTRUCTIONS

FOR

SAFETY RECALL 20TA04

**CERTAIN ENGINE BLOCKS CAN CAUSE ENGINE FAILURE LEADING TO
ENGINE STALL (non-hybrid) and/or FIRE RISK**

CERTAIN 2020 CAMRY

(2020 CAMRY HV is a separate document)

Update 8/18/2021: Instructions added for engine short block replacement in the case engine assembly is not available, and Tech Certification updated.

Update 6/24/2020: Engine Assembly Replacement procedure is now included

The repair quality of covered vehicles is extremely important to Toyota. All dealership technicians performing this repair are required to successfully complete the most current version of the E-Learning course "Safety Recall and Service Campaign Essentials". To ensure that all vehicles have the repair performed correctly; technicians performing this repair are required to currently have completed all of the following courses:

- T151 - Toyota Engine Service and Repair

It is the dealership's responsibility to select technicians that have completed the above courses to perform this repair. Carefully review your resources, the technician skill level, and ability before assigning technicians to this repair. It is important to consider technician days off and vacation schedules to ensure there are properly trained technicians available to perform this repair at all times.

I. OPERATION FLOW CHART

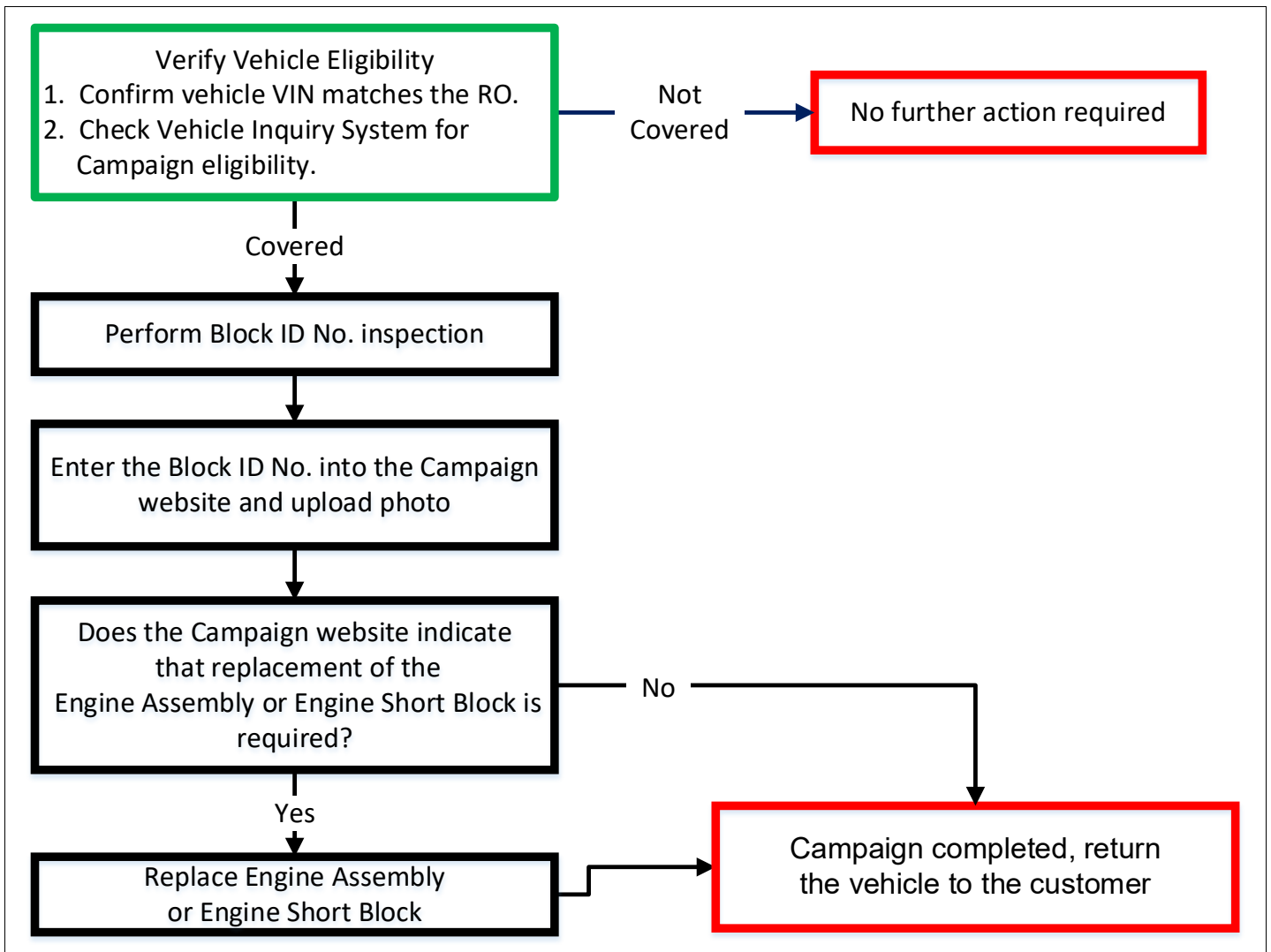

II. IDENTIFICATION OF AFFECTED VEHICLES

- Check the TIS Vehicle Inquiry System to confirm the VIN is involved in this Safety Recall, and that it has not already been completed prior to dealer shipment or by another dealer.
- TMS warranty will not reimburse dealers for repairs completed on vehicles that are not affected or were completed by another dealer.

III. PREPARATION

A. PARTS

INSPECTION ONLY:

No parts are required for the inspection of the Block ID No. Parts will only be necessary if the replacement of the Engine Assembly or Engine Short Block is required, as determined by the inspection.

ENGINE ASSEMBLY OR ENGINE SHORT BLOCK REPLACEMENT:

Because of the extensive list of parts and variations of the model, a website has been created to detail the required parts for each vehicle. Reference the following website for a detailed parts list for **each specific VIN**:

<https://20TA04-20LA02-safety-recall.imagespm.info/>

Note: Warranty will only reimburse dealers for the part numbers listed on the website. Any other part numbers will not be accepted on the campaign claim.

B. TOOLS & EQUIPMENT

- Techstream
- Engine Hoist
- Standard Hand Tools
- Engine Stand
- Torque Wrench

SST – These Special Service Tools are required for this repair:

Part Number	Tool Name	Quantity
00002-11100-02	Transmission Fluid Pump	1
09213-54015	Crankshaft Tool	1
09330-00021	Companion Flange Tool	1
09950-50013	Puller Set	1

IV. BACKGROUND

Some of the subject vehicles may be equipped with an engine block that was manufactured incorrectly. This issue may cause coolant to leak internally and/or externally during normal engine operation. This can lead to engine noise, engine smoke, warning lights/malfunction indicator illumination, an audible chime sounding, and/or, in some cases, engine overheating and possible internal mechanical engine damage. If this occurs in a conventional gasoline vehicle, it is possible the vehicle could stall while driving at higher speeds without prior warning, increasing the risk of a crash. For both hybrid and conventional gasoline vehicles, the mechanical engine damage could cause engine oil to leak, which, in the presence of an ignition source, can lead to an increased risk of fire.

NOTE: If the engine stalls in a hybrid vehicle, the vehicle will enter a fail safe driving mode, allowing the driver to operate the vehicle at reduced power for certain distances to maneuver the vehicle to a safe location.

V. COMPONENTS

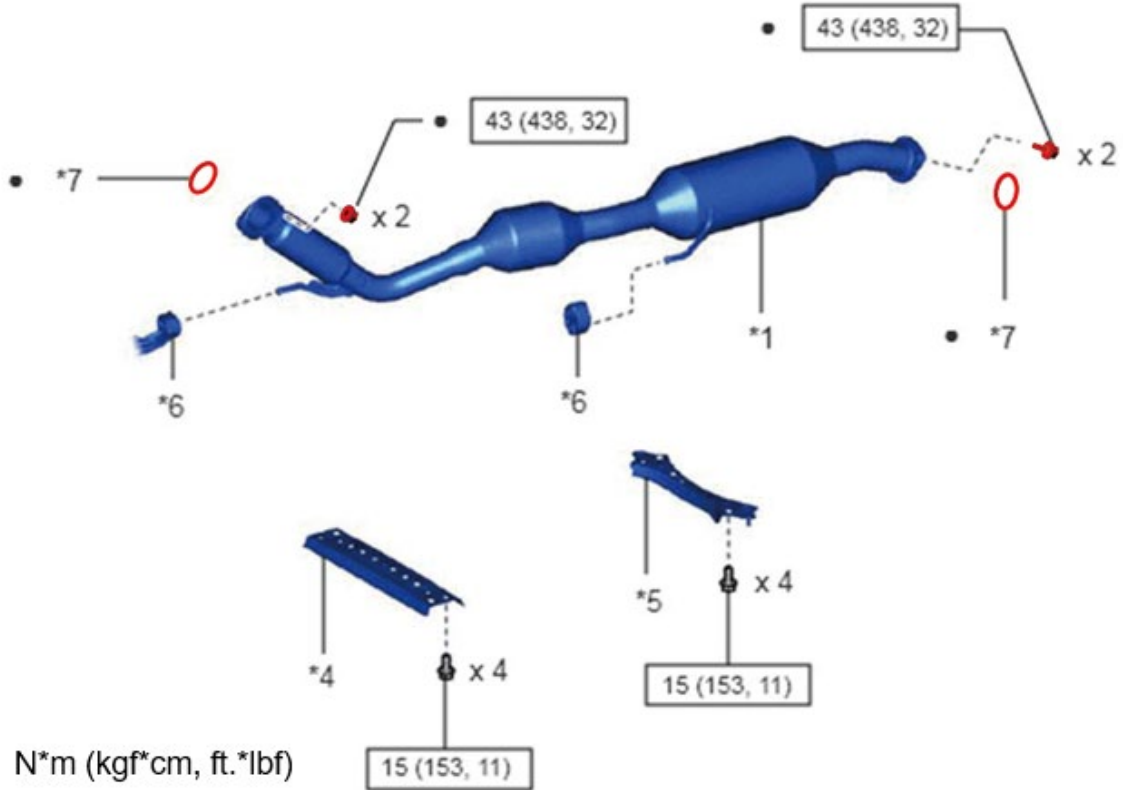

*1	FRONT EXHAUST PIPE ASSEMBLY (TWC: Rear Catalyst)	*2	NO. 1 UPPER FRONT FLOOR HEAT INSULATOR
*3	FRONT LOWER NO. 1 FLOOR HEAT INSULATOR	*4	CENTER FLOOR CROSSMEMBER BRACE
*5	FRONT CENTER FLOOR BRACE	*6	EXHAUST PIPE SUPPORT
*7	GASKET	●	Non-reusable part

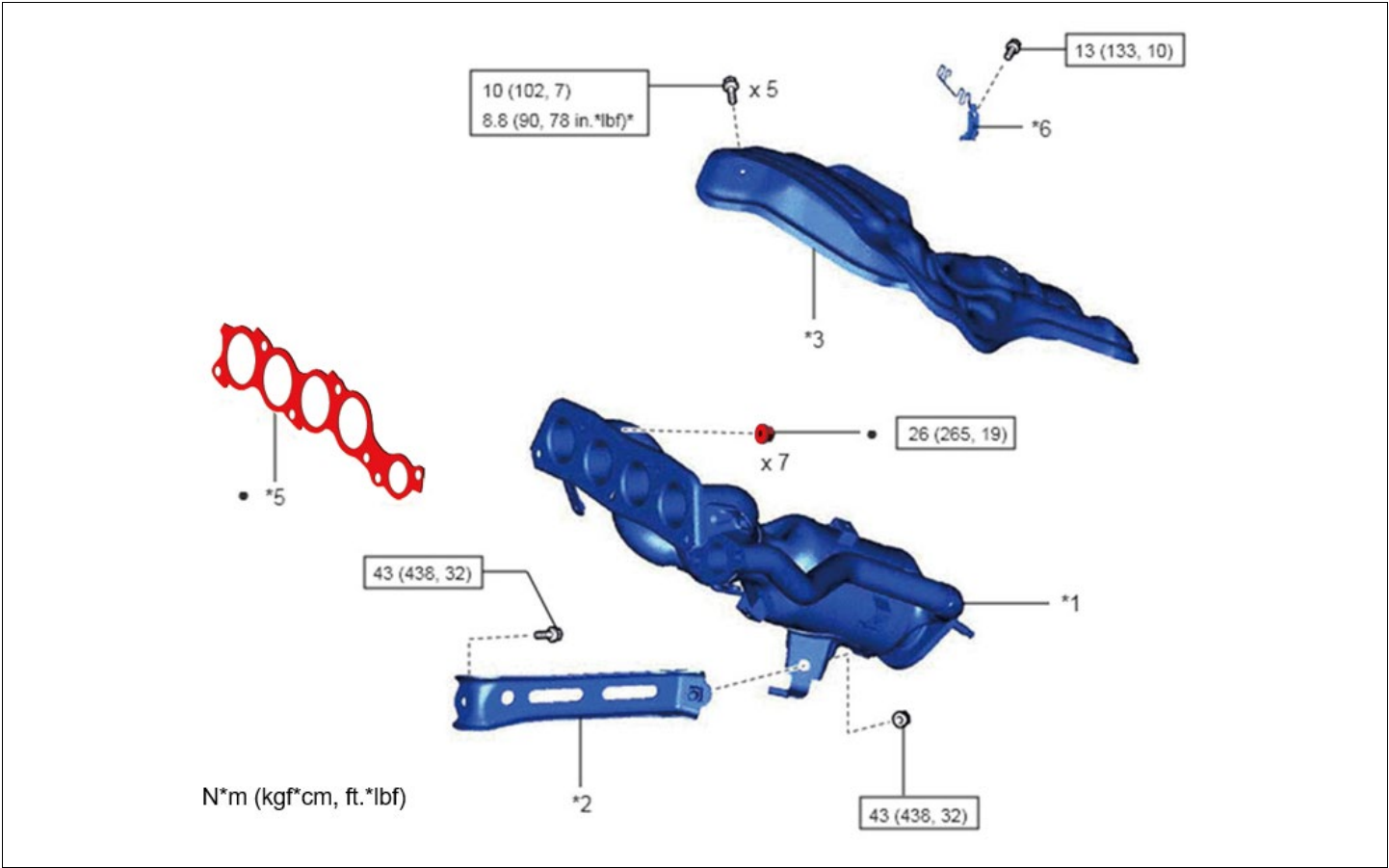

N*m (kgf*cm, ft.*lbf)

*1	EXHAUST MANIFOLD (TWC: Front Catalyst)	*2	MANIFOLD STAY
*3	NO. 1 EXHAUST MANIFOLD HEAT INSULATOR	*4	NO. 2 EXHAUST MANIFOLD HEAT INSULATOR
*5	EXHAUST MANIFOLD TO HEAD GASKET	*6	WIRE HARNESS CLAMP BRACKET
●	Non-reusable part	-	-

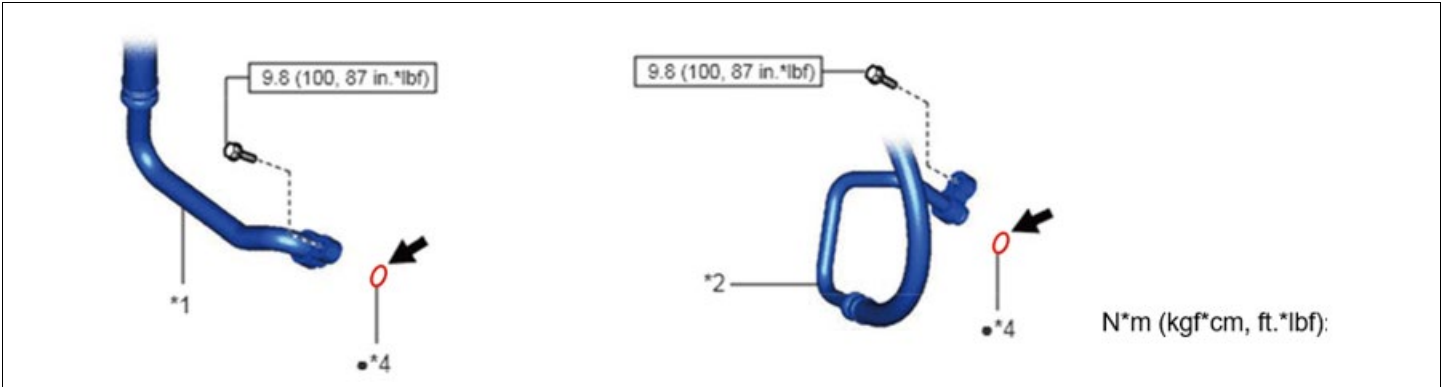

N*m (kgf*cm, ft.*lbf):

*1	SUCTION HOSE SUB-ASSEMBLY	*2	NO. 1 COOLER REFRIGERANT DISCHARGE HOSE SUB-ASSEMBLY
*4	O-RING	●	Non-reusable part

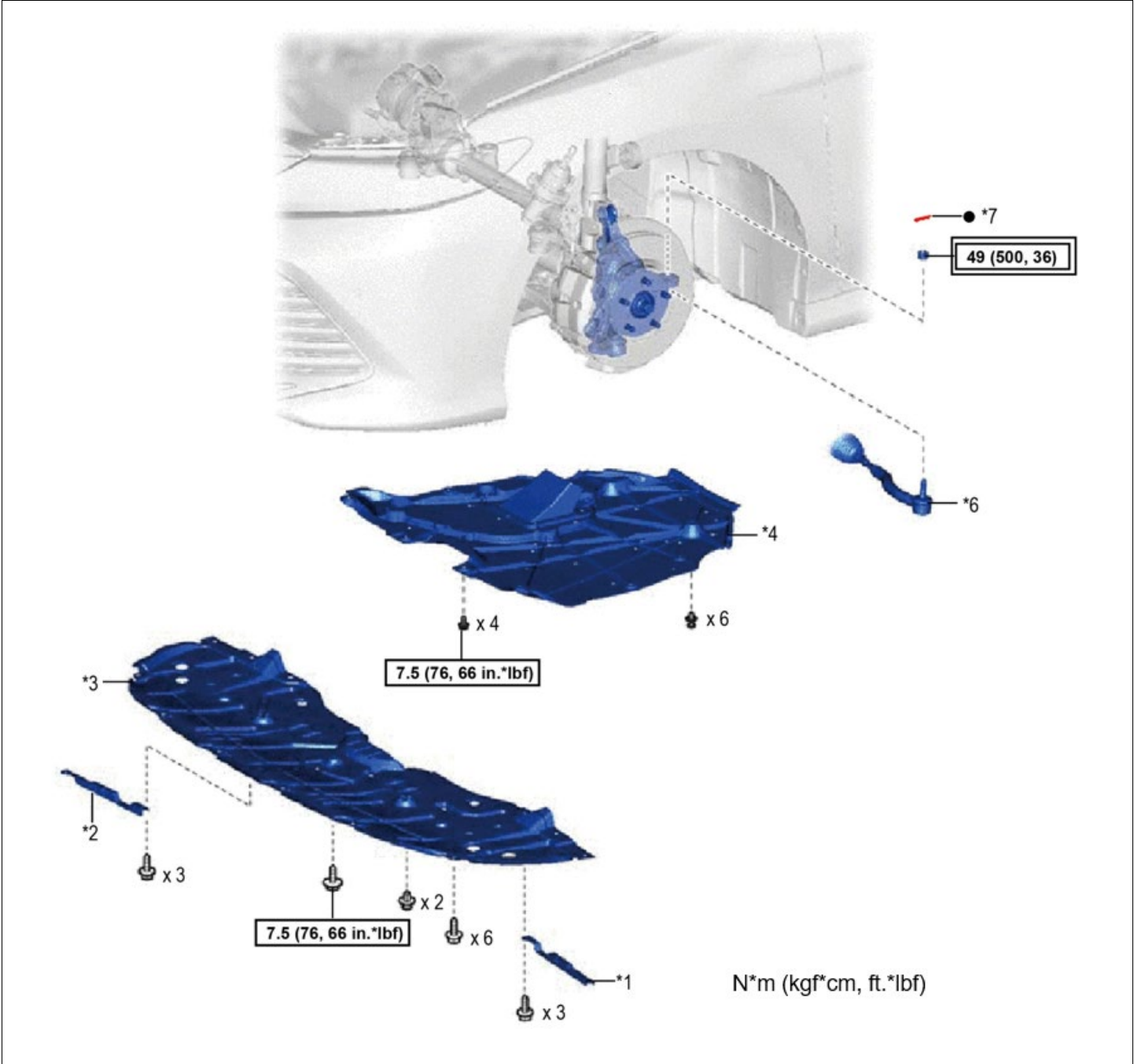

*1	FRONT WHEEL OPENING EXTENSION PAD LH	*2	FRONT WHEEL OPENING EXTENSION PAD RH
*3	NO. 1 ENGINE UNDER COVER	*4	NO. 2 ENGINE UNDER COVER ASSEMBLY
*5	STEERING INTERMEDIATE SHAFT ASSEMBLY	*6	TIE ROD ASSEMBLY LH
*7	COTTER PIN	●	Non-reusable part

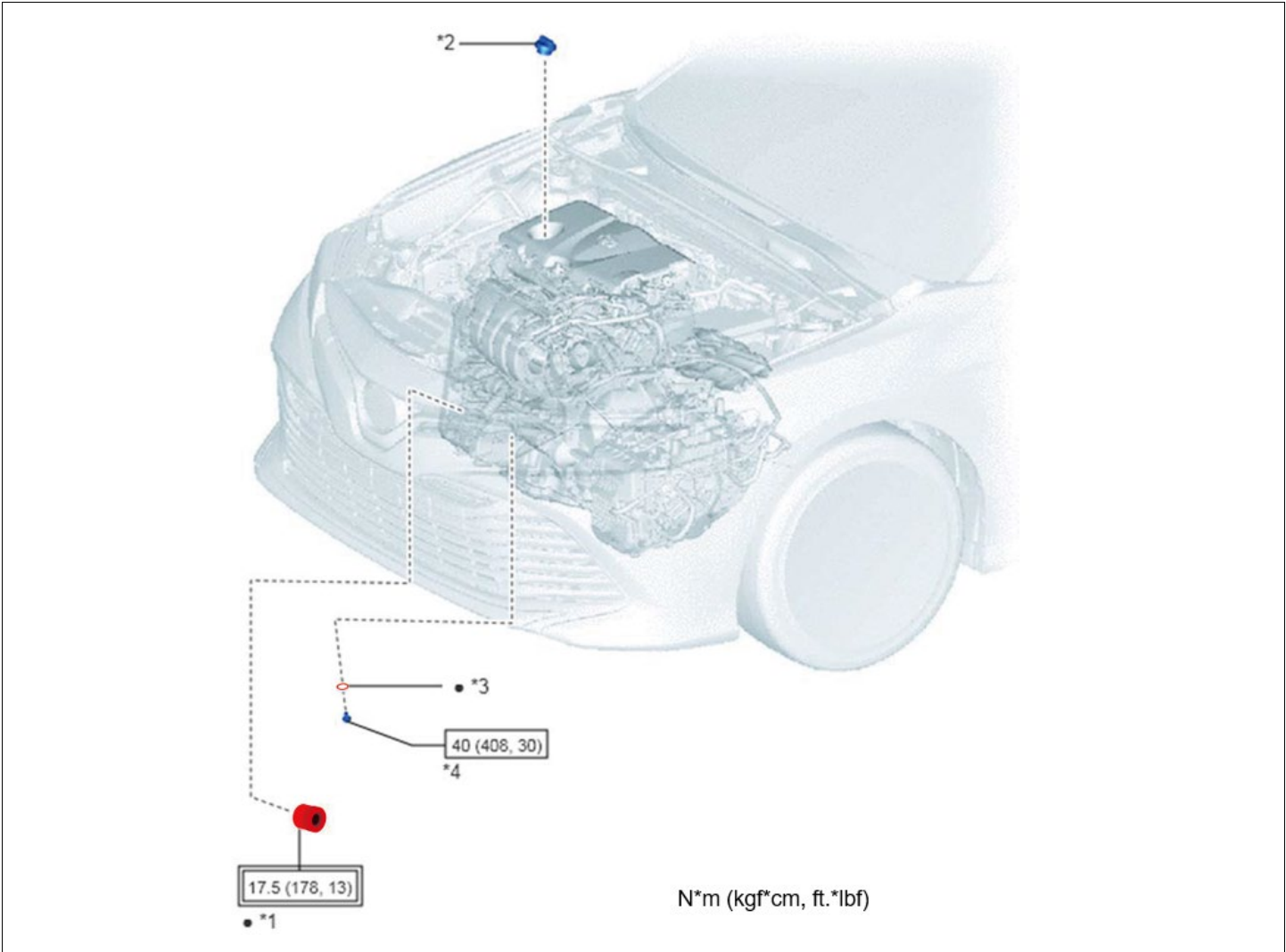

*1	OIL FILTER SUB-ASSEMBLY	*2	OIL FILLER CAP SUB-ASSEMBLY
*3	GASKET	*4	OIL PAN DRAIN PLUG
●	Non-reusable part	-	-

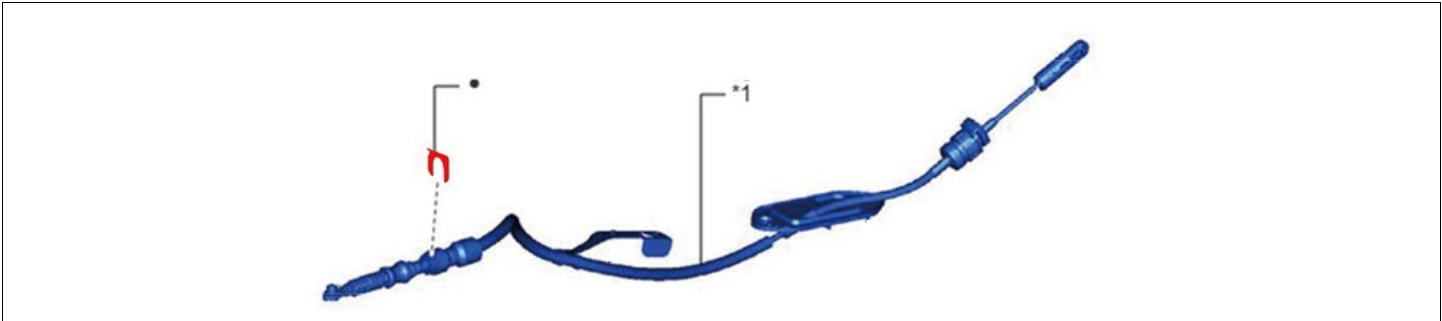

*1	TRANSMISSION CONTROL CABLE ASSEMBLY	●	Non-reusable part
----	-------------------------------------	---	-------------------

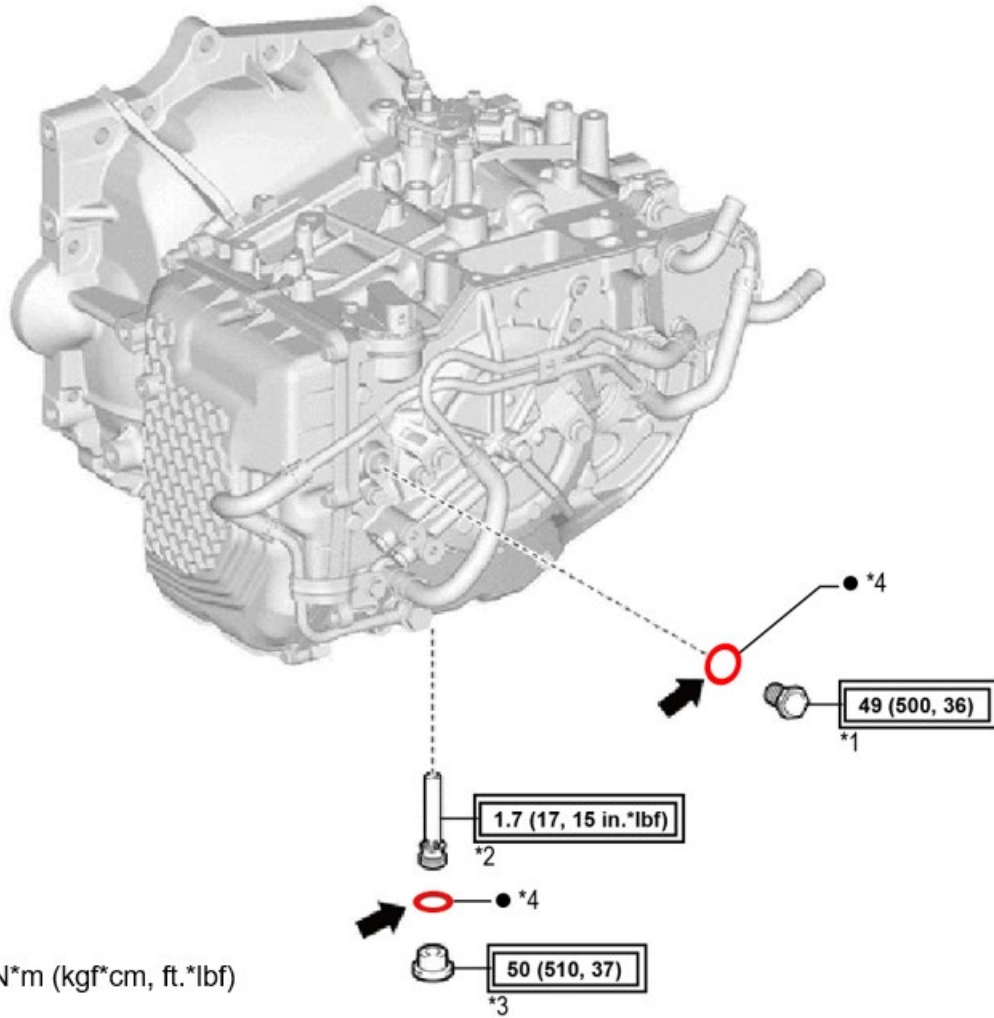

*1	REFILL PLUG	*2	NO. 1 TRANSMISSION OIL FILLER TUBE
*3	OVERFLOW PLUG	*4	GASKET
	Tightening torque for "Major areas involving basic vehicle performance such as moving/turning/stopping": N*m (kgf*cm, ft.*lbf)	●	Non-reusable part
	Toyota Genuine ATF WS	-	-

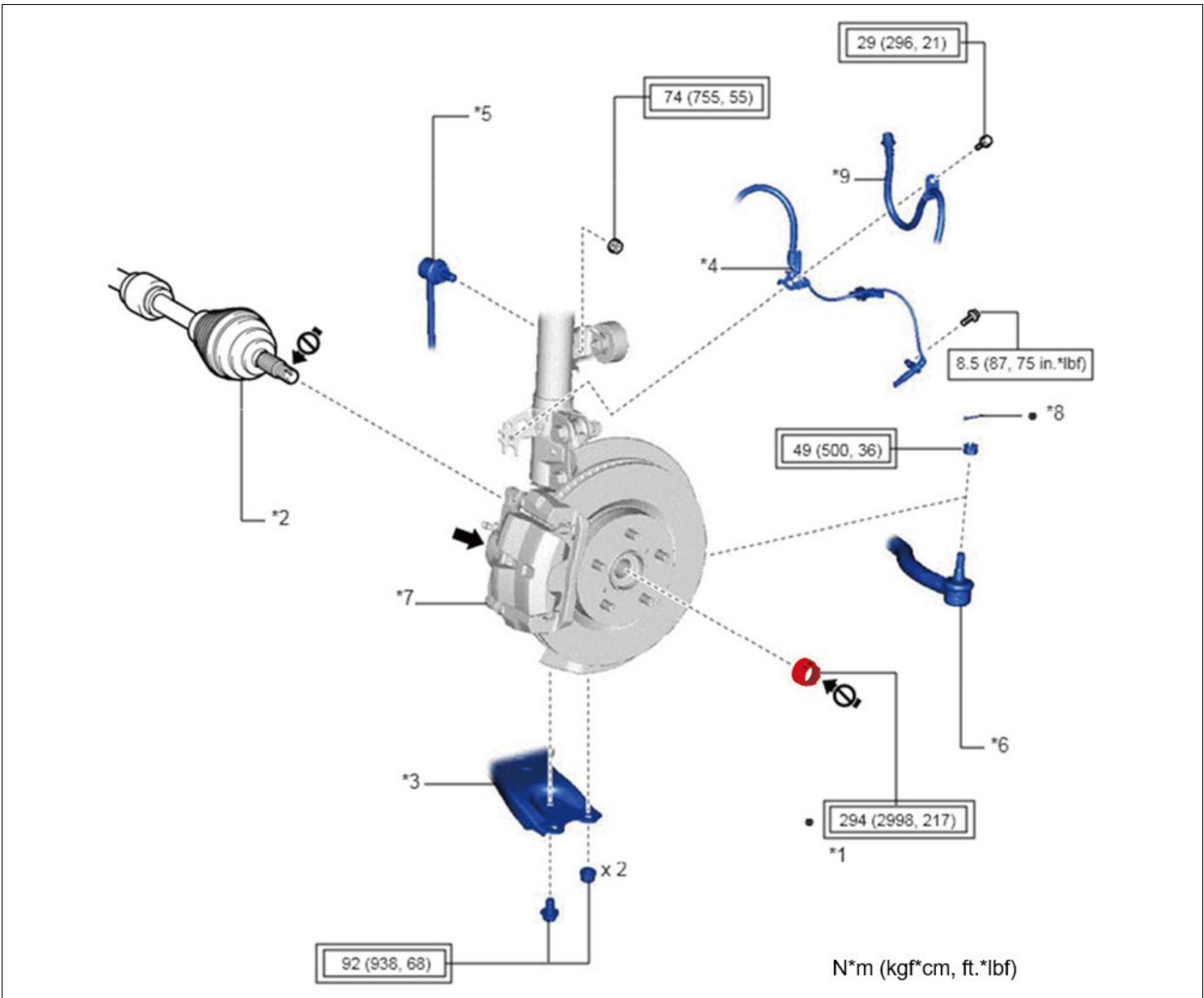

*1	FRONT AXLE SHAFT NUT	*2	FRONT DRIVE SHAFT ASSEMBLY
*3	FRONT LOWER NO. 1 SUSPENSION ARM SUB-ASSEMBLY	*4	FRONT SPEED SENSOR
*5	FRONT STABILIZER LINK ASSEMBLY	*6	TIE ROD ASSEMBLY
*7	FRONT AXLE ASSEMBLY	*8	COTTER PIN
*9	FRONT FLEXIBLE HOSE	-	-
	Tightening torque for "Major areas involving basic vehicle performance such as moving/turning/stopping": N*m (kgf*cm, ft.*lbf)		N*m (kgf*cm, ft.*lbf): Specified torque
•	Non-reusable part		Toyota Genuine ATF WS
	Do not apply lubricants to the threaded parts	-	-

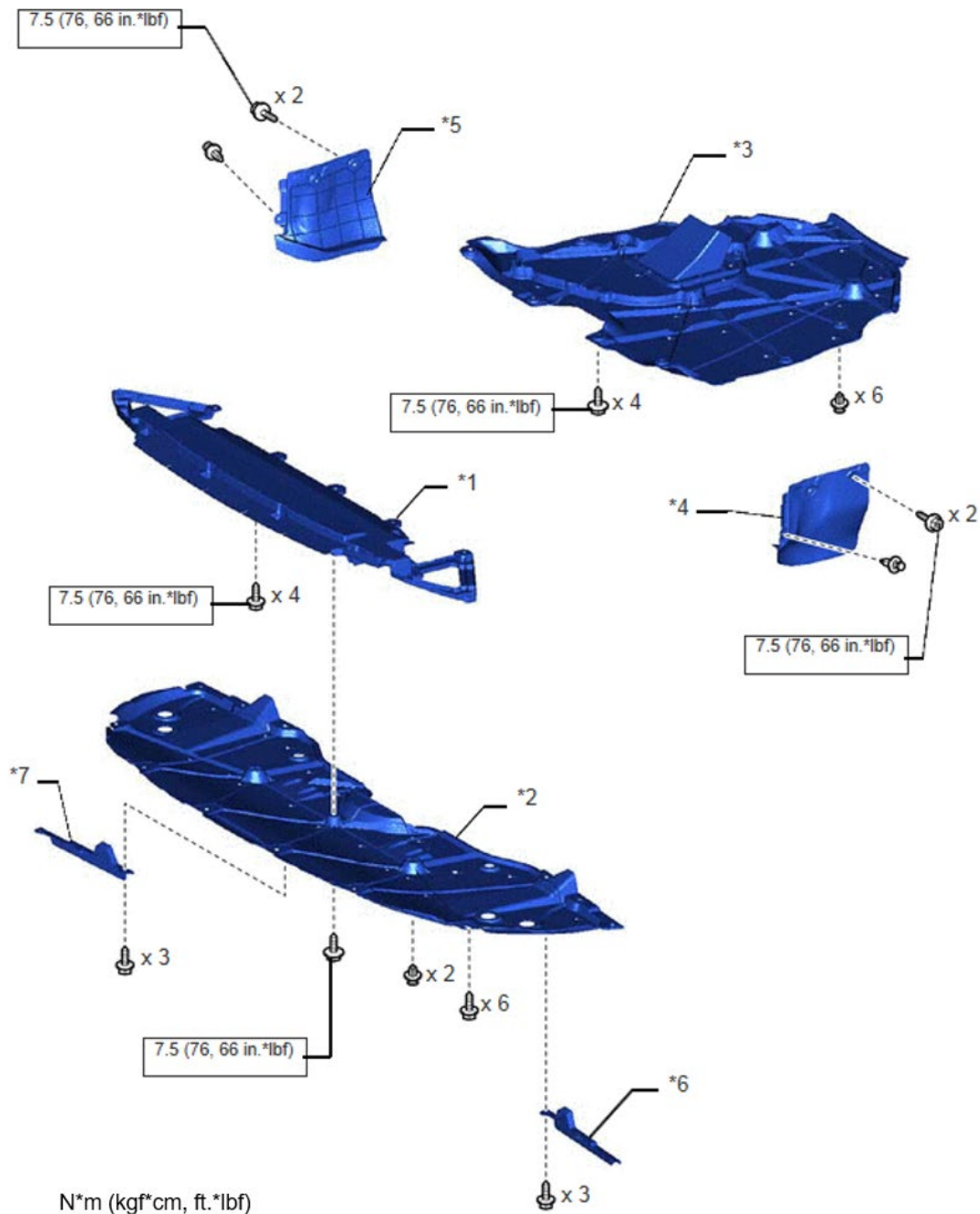

*1	FRONT LOWER BUMPER ABSORBER	*2	NO. 1 ENGINE UNDER COVER
*3	NO. 2 ENGINE UNDER COVER ASSEMBLY	*4	FRONT FENDER APRON SEAL LH
*5	FRONT FENDER APRON SEAL RH	*6	FRONT WHEEL OPENING EXTENSION PAD LH
*7	FRONT WHEEL OPENING EXTENSION PAD RH		N*m (kgf*cm, ft.*lbf): Specified torque

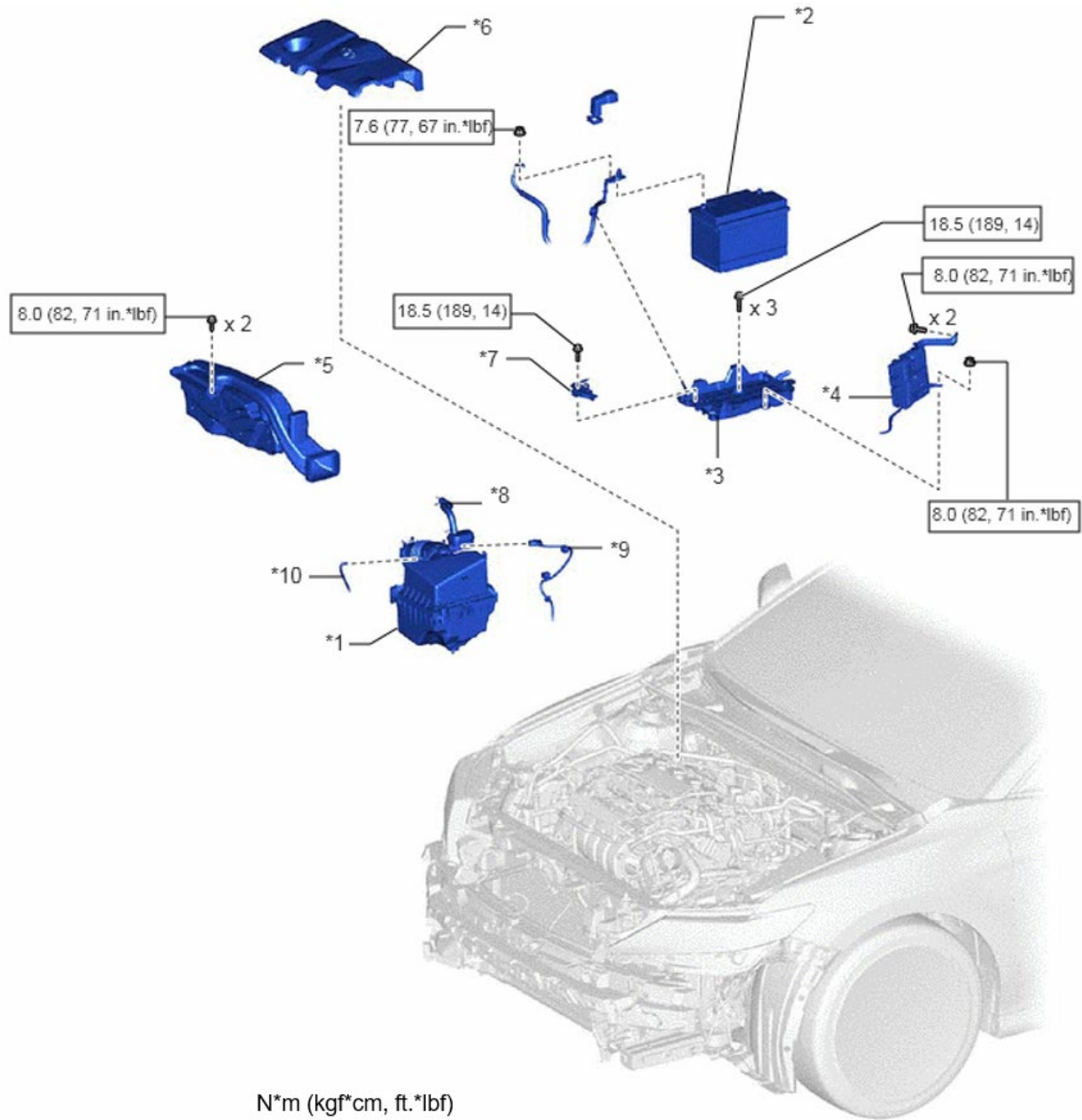

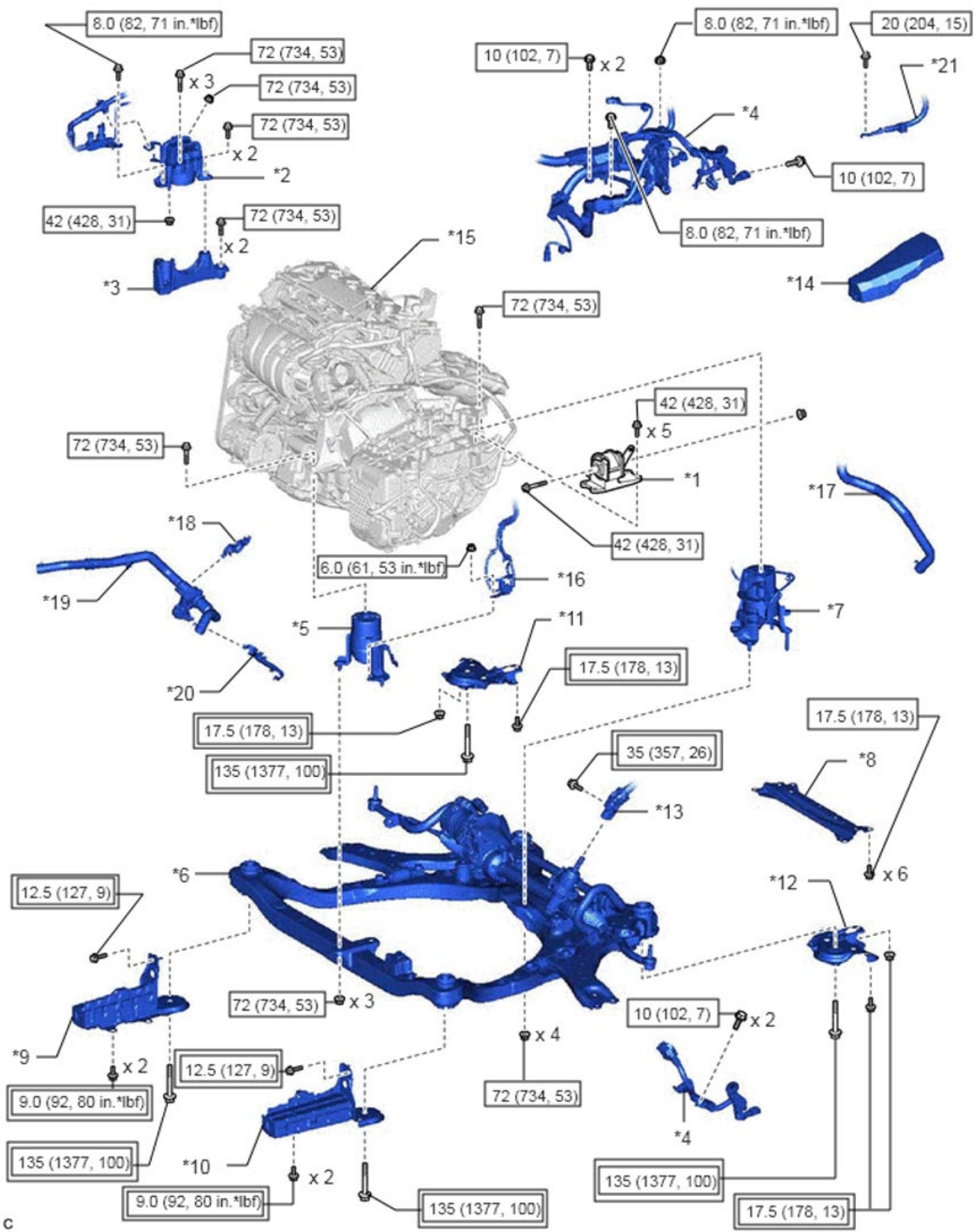

*1	AIR CLEANER ASSEMBLY WITH AIR CLEANER HOSE	*2	BATTERY
*3	BATTERY CLAMP SUB-ASSEMBLY	*4	ECM
*5	INLET AIR CLEANER ASSEMBLY	*6	NO. 1 ENGINE COVER SUB-ASSEMBLY
*7	NO. 2 BATTERY CLAMP	*8	NO. 2 VENTILATION HOSE
*9	MASS AIR FLOW METER SUB-ASSEMBLY CONNECTOR	*10	VACUUM HOSE
	N*m (kgf*cm, ft.*lbf): Specified torque	-	-



c

(Diagram detail on next page)

*1	REAR NO. 2 ENGINE MOUNTING INSULATOR	*2	ENGINE MOUNTING INSULATOR SUB-ASSEMBLY RH
*3	ENGINE MOUNTING SPACER	*4	WIRE HARNESS
*5	FRONT ENGINE MOUNTING INSULATOR	*6	FRONT FRAME ASSEMBLY
*7	REAR ENGINE MOUNTING INSULATOR	*8	BODY MOUNTING PLATE
*9	FRONT BUMPER EXTENSION SUB-ASSEMBLY RH	*10	FRONT BUMPER EXTENSION SUB-ASSEMBLY LH
*11	FRONT SUSPENSION MEMBER BRACKET SUB-ASSEMBLY RH	*12	FRONT SUSPENSION MEMBER BRACKET SUB-ASSEMBLY LH
*13	STEERING INTERMEDIATE SHAFT ASSEMBLY	*14	NO. 2 RELAY BLOCK COVER
*15	ENGINE ASSEMBLY WITH TRANSAXLE	*16	VACUUM HOSE
*17	WATER BY-PASS HOSE ASSEMBLY	*18	HOSE CLAMP
*19	FLOW SHUTTING VALVE (NO. 1 WATER BY-PASS HOSE)	*20	TRANSMISSION BREATHER CLAMP
*21	EARTH WIRE	-	-
	Tightening torque for "Major areas involving basic vehicle performance such as moving/turning/stopping": N*m (kgf*cm, ft.*lbf)		N*m (kgf*cm, ft.*lbf): Specified torque

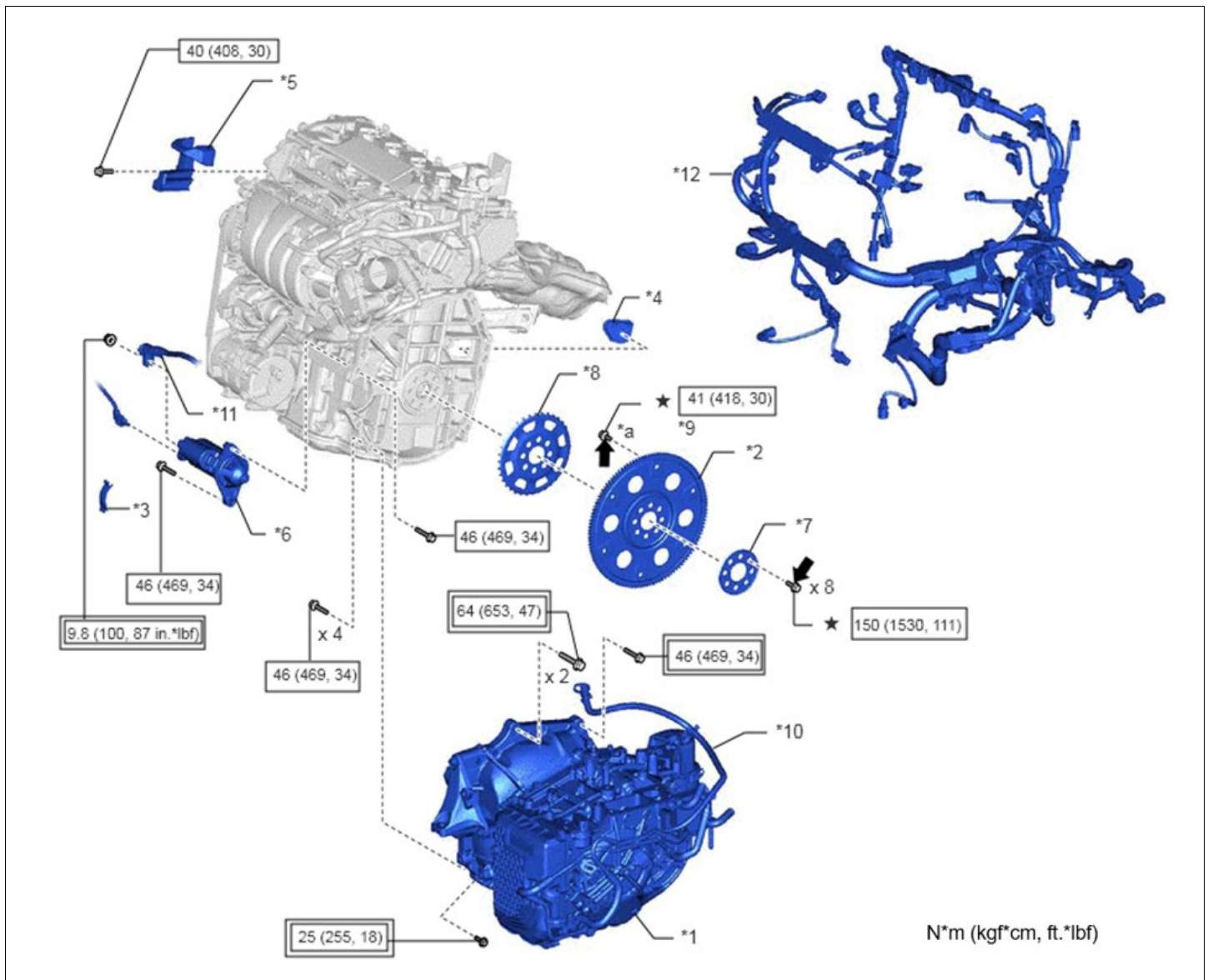

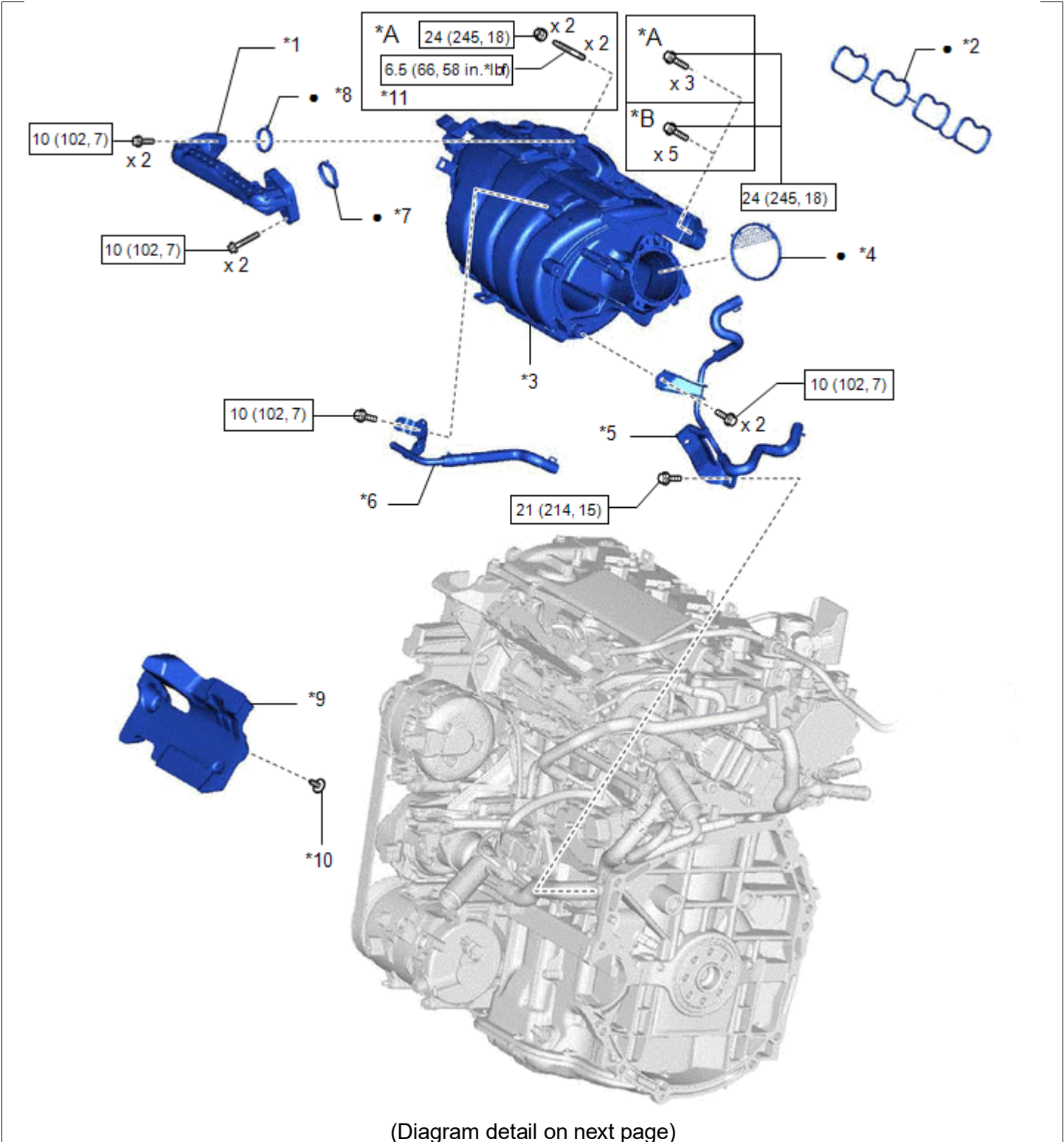

N*m (kgf*cm, ft.*lbf)

*1	AUTOMATIC TRANSAXLE ASSEMBLY	*2	DRIVE PLATE AND RING GEAR SUB-ASSEMBLY
*3	FLYWHEEL HOUSING SIDE COVER	*4	FLYWHEEL HOUSING UNDER COVER
*5	FUEL DELIVERY GUARD	*6	STARTER ASSEMBLY
*7	REAR DRIVE PLATE SPACER	*8	NO. 1 CRANKSHAFT POSITION SENSOR PLATE
*9	DRIVE PLATE AND TORQUE CONVERTER ASSEMBLY SETTING BOLT	*10	BREATHER PLUG HOSE
*11	NO. 2 ENGINE WIRE	*12	ENGINE WIRE
*a	<ul style="list-style-type: none"> • BLACK COLOR: x 1 • SILVER COLOR: x 5 	-	-
	Adhesive 1324	★	Precoated part



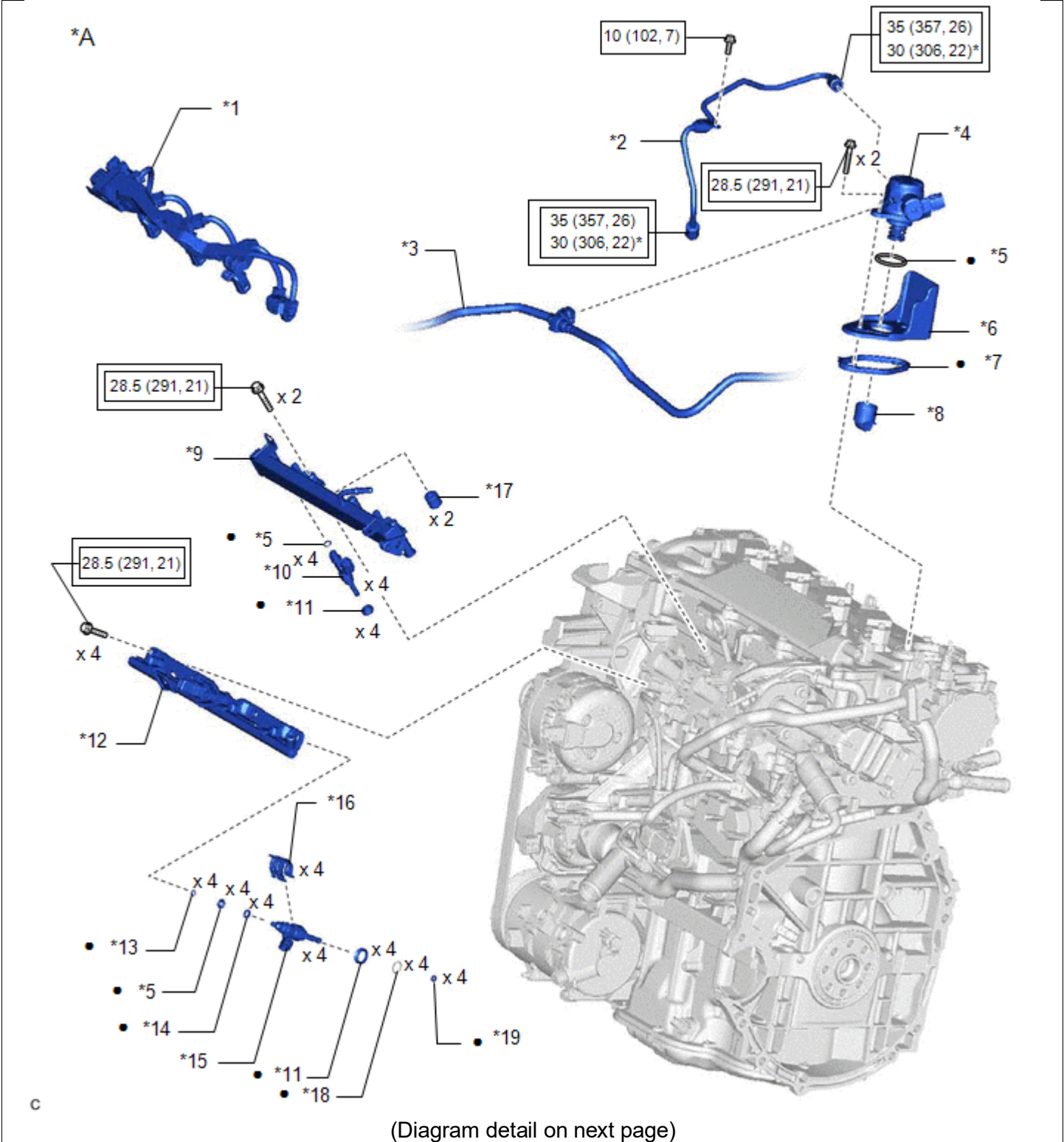

*A	w/ Stud Bolt	*B	w/o Stud Bolt
*1	NO. 1 EGR PIPE SUB-ASSEMBLY	*2	NO. 1 INTAKE MANIFOLD TO HEAD GASKET
*3	INTAKE MANIFOLD	*4	THROTTLE BODY GASKET
*5	NO. 2 WATER BY-PASS PIPE	*6	NO. 3 WATER BY-PASS PIPE
*7	EGR VALVE ADAPTER GASKET	*8	EGR INLET GASKET
*9	NO. 3 ENGINE COVER	*10	CLIP
*11	STUD BOLT	-	-
	N*m (kgf*cm, ft.*lbf): Specified torque	•	Non-reusable part

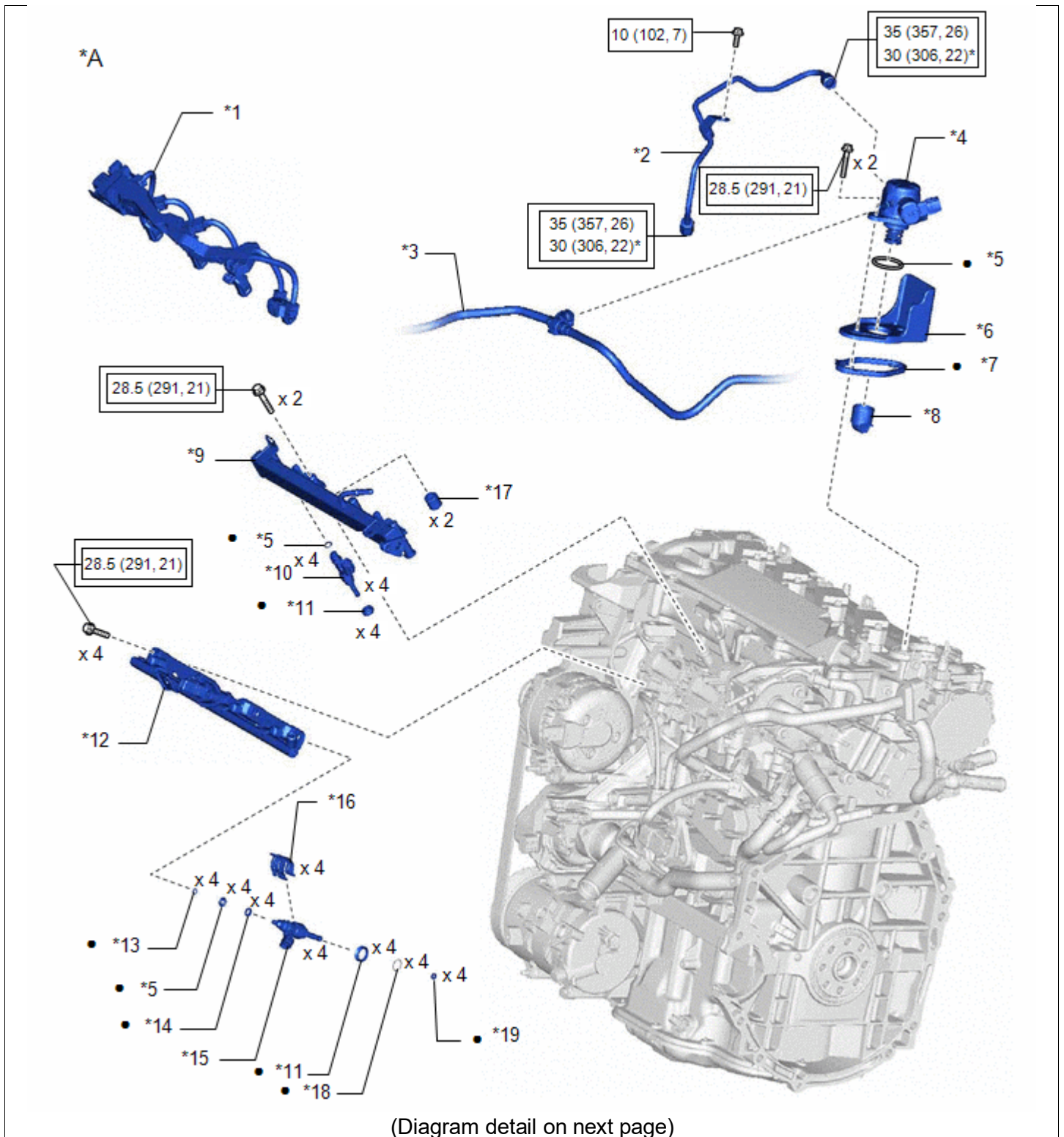

*A	for EGR Valve Bracket Connection Type	-	-
*1	NO. 5 ENGINE WIRE	*2	NO. 1 FUEL PIPE SUB-ASSEMBLY
*3	FUEL TUBE SUB-ASSEMBLY	*4	FUEL PUMP ASSEMBLY (for High Pressure)
*5	O-RING	*6	FUEL PUMP FLANGE
*7	FUEL PUMP SPACER GASKET	*8	FUEL PUMP LIFTER ASSEMBLY
*9	FUEL DELIVERY PIPE WITH SENSOR SUB-ASSEMBLY	*10	PORT FUEL INJECTOR ASSEMBLY
*11	INJECTOR VIBRATION INSULATOR	*12	FUEL DELIVERY PIPE
*13	NO. 3 FUEL INJECTOR BACK-UP RING	*14	NO. 1 FUEL INJECTOR BACK-UP RING
*15	DIRECT FUEL INJECTOR ASSEMBLY	*16	NOZZLE HOLDER CLAMP
*17	NO. 1 DELIVERY PIPE SPACER	*18	C-RING
*19	FUEL INJECTOR SEAL	-	-
	Tightening torque for "Major areas involving basic vehicle performance such as moving/turning/stopping": N*m (kgf*cm, ft.*lbf)		N*m (kgf*cm, ft.*lbf): Specified torque
*	For use with a union nut wrench	●	Non-reusable part



*A	for Cylinder Head Cover Sub-assembly Connection Type	-	-
*1	NO. 5 ENGINE WIRE	*2	NO. 1 FUEL PIPE SUB-ASSEMBLY
*3	FUEL TUBE SUB-ASSEMBLY	*4	FUEL PUMP ASSEMBLY (for High Pressure)
*5	O-RING	*6	FUEL PUMP FLANGE
*7	FUEL PUMP SPACER GASKET	*8	FUEL PUMP LIFTER ASSEMBLY
*9	FUEL DELIVERY PIPE WITH SENSOR SUB-ASSEMBLY	*10	PORT FUEL INJECTOR ASSEMBLY
*11	INJECTOR VIBRATION INSULATOR	*12	FUEL DELIVERY PIPE
*13	NO. 3 FUEL INJECTOR BACK-UP RING	*14	NO. 1 FUEL INJECTOR BACK-UP RING
*15	DIRECT FUEL INJECTOR ASSEMBLY	*16	NOZZLE HOLDER CLAMP
*17	NO. 1 DELIVERY PIPE SPACER	*18	C-RING
*19	FUEL INJECTOR SEAL	-	-
	Tightening torque for "Major areas involving basic vehicle performance such as moving/turning/stopping": N*m (kgf*cm, ft.*lbf)		N*m (kgf*cm, ft.*lbf): Specified torque
*	For use with a union nut wrench	●	Non-reusable part

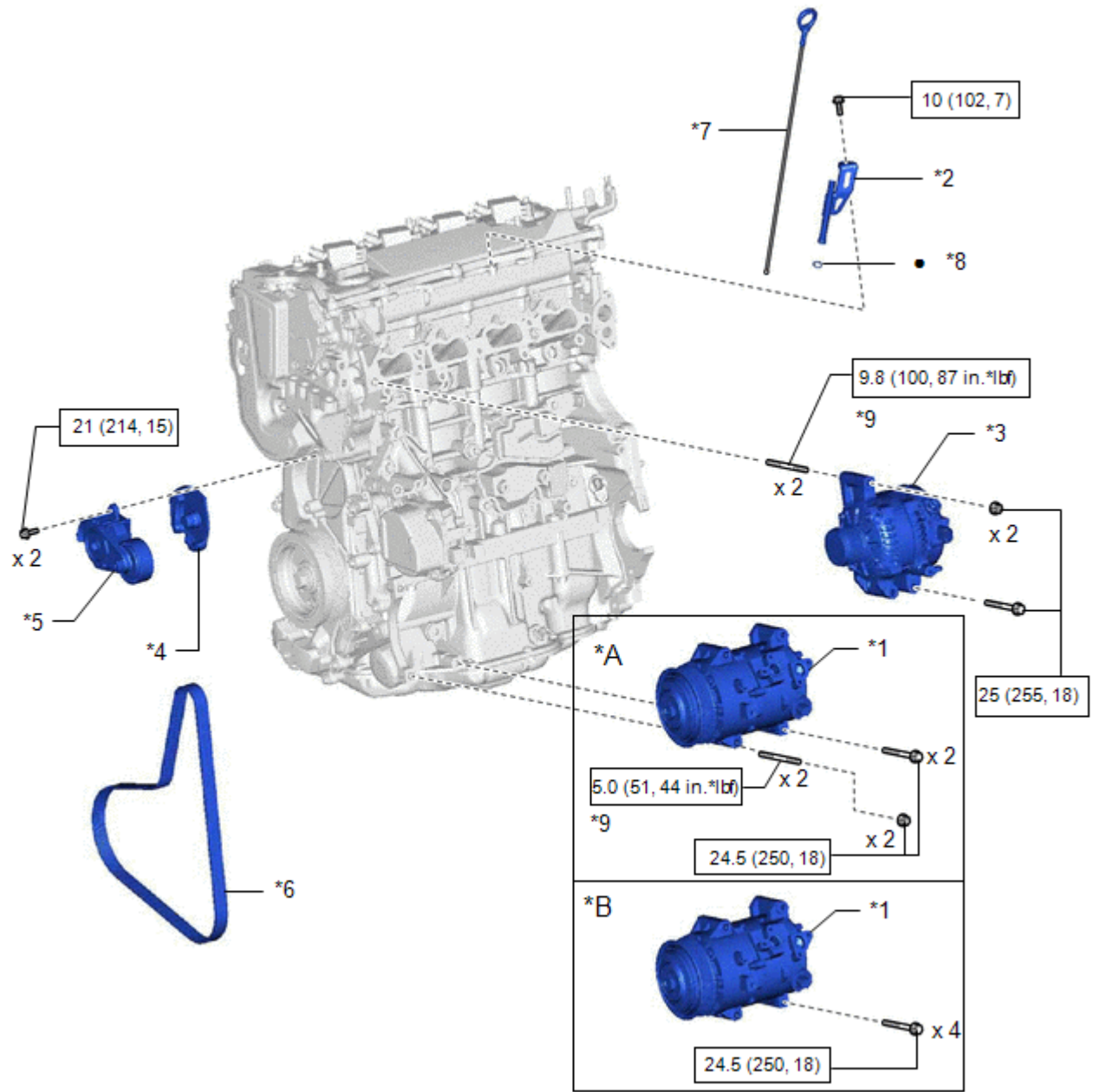



c

(Diagram detail on next page)

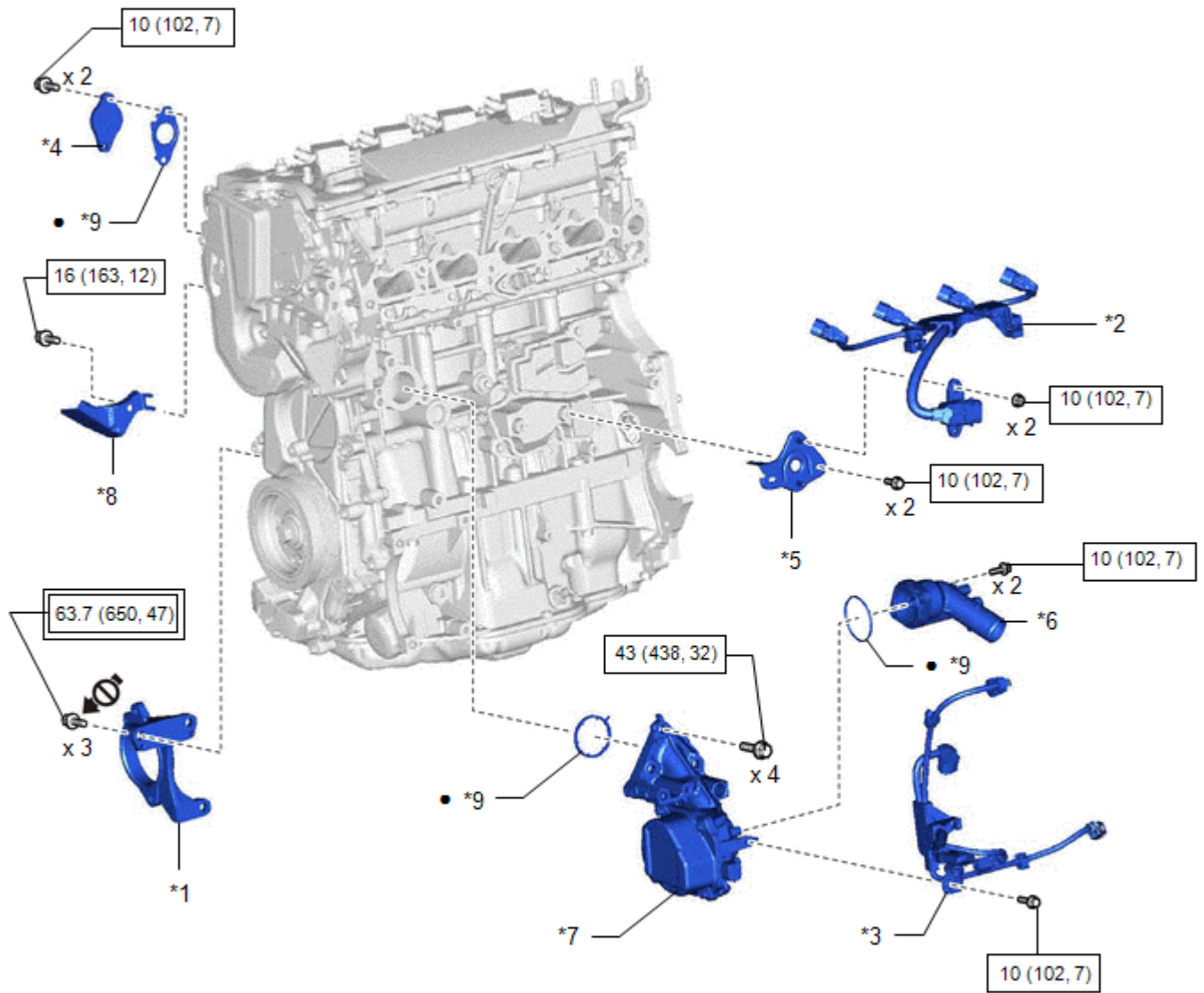
*A	for Type A	*B	for Type B
*1	COMPRESSOR ASSEMBLY WITH PULLEY	*2	ENGINE OIL LEVEL DIPSTICK GUIDE
*3	GENERATOR ASSEMBLY	*4	NO. 2 TIMING CHAIN COVER INSULATOR
*5	V-RIBBED BELT TENSIONER ASSEMBLY	*6	V-RIBBED BELT
*7	ENGINE OIL LEVEL DIPSTICK	*8	O-RING
*9	STUD BOLT	-	-
	N*m (kgf*cm, ft.*lbf): Specified torque	•	Non-reusable part



(Diagram detail on next page)

*1	DRIVE SHAFT BEARING BRACKET	*2	NO. 6 ENGINE WIRE
*3	SENSOR WIRE	*4	WATER SEAL PLATE
*5	WIRE HARNESS CLAMP BRACKET	*6	WATER INLET WITH THERMOSTAT SUB-ASSEMBLY
*7	ENGINE WATER PUMP ASSEMBLY (WATER INLET HOUSING)	*8	NO. 3 EXHAUST MANIFOLD HEAT INSULATOR
*9	GASKET	-	-
	Tightening torque for "Major areas involving basic vehicle performance such as moving/turning/stopping": N*m (kgf*cm, ft.*lbf)		N*m (kgf*cm, ft.*lbf): Specified torque
•	Non-reusable part		Do not apply lubricants to the threaded parts

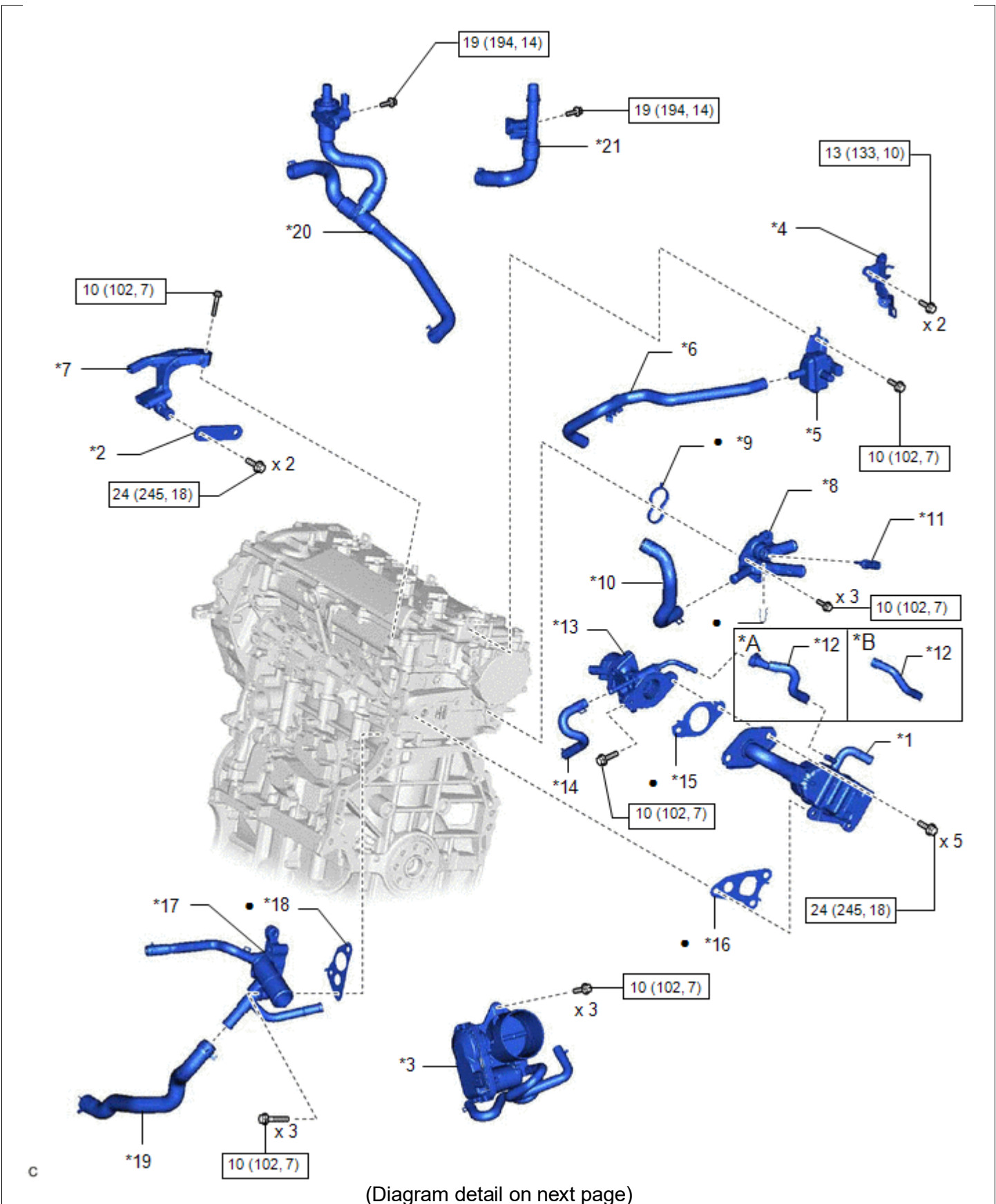

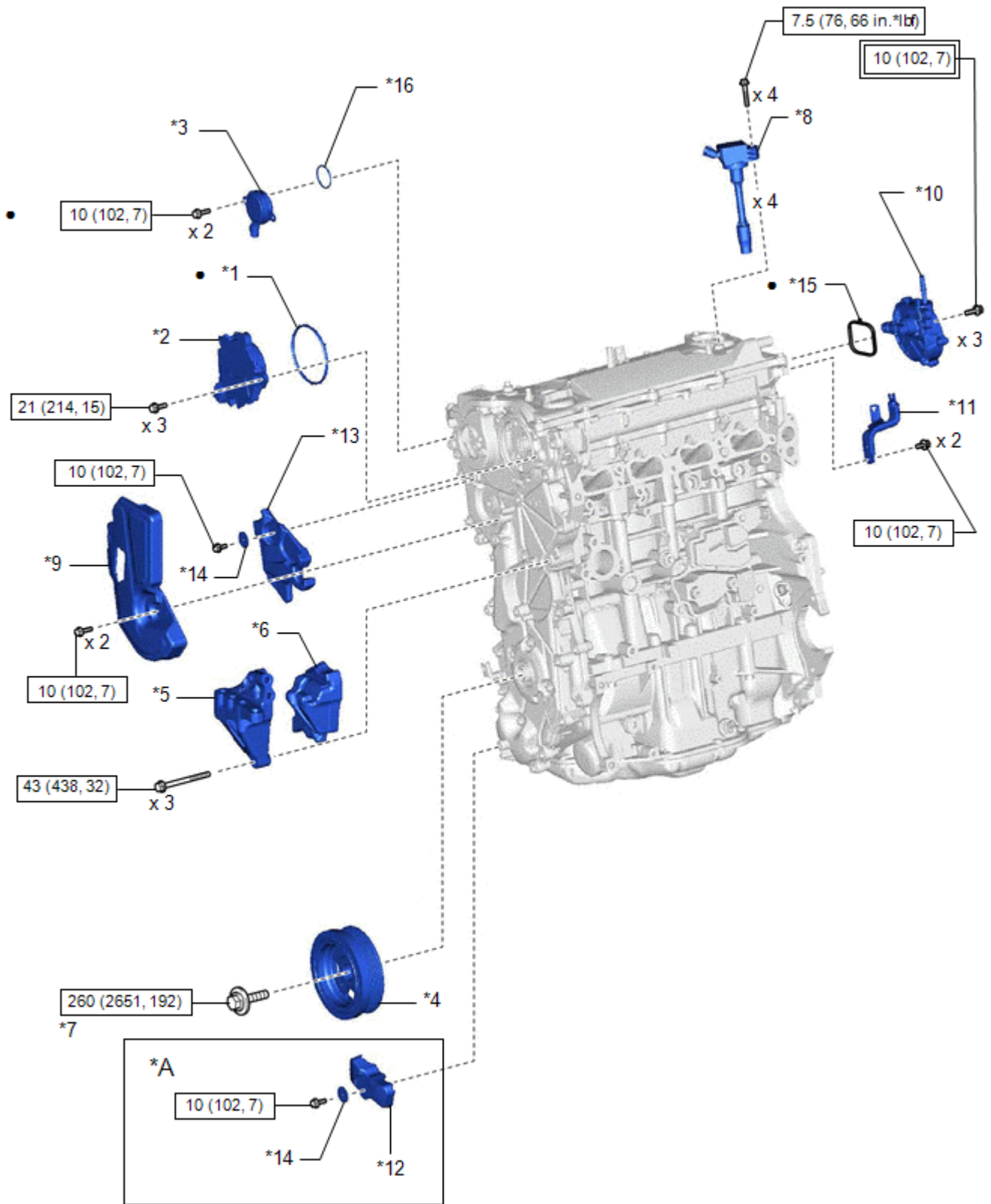

(Diagram detail on next page)

*A	w/ Water Hose Connector	*B	w/o Water Hose Connector
*1	EGR COOLER ASSEMBLY	*2	NO. 1 EGR COOLER BRACKET
*3	THROTTLE BODY WITH MOTOR ASSEMBLY	*4	WATER HOSE CLAMP BRACKET
*5	PURGE VALVE (PURGE VSV)	*6	FUEL VAPOR FEED HOSE
*7	EGR VALVE BRACKET	*8	OUTLET WATER BY-PASS SUB-ASSEMBLY
*9	OUTLET WATER PIPE GASKET	*10	NO. 3 WATER BY-PASS HOSE
*11	ENGINE COOLANT TEMPERATURE SENSOR	*12	WATER HOSE
*13	EGR VALVE ASSEMBLY	*14	NO. 8 WATER BY-PASS HOSE
*15	EGR VALVE GASKET	*16	EGR COOLER GASKET
*17	WATER OUTLET	*18	WATER OUTLET GASKET
*19	NO. 7 WATER BY-PASS HOSE	*20	FLOW SHUTTING VALVE (WATER BY-PASS HOSE ASSEMBLY)
*21	NO. 2 WATER BY-PASS PIPE SUB-ASSEMBLY	-	-
	N*m (kgf*cm, ft.*lbf): Specified torque	•	Non-reusable part



(Diagram detail on next page)

*A	w/ Cover	-	-
*1	CAM TIMING CONTROL MOTOR O-RING	*2	CAM TIMING CONTROL MOTOR WITH EDU ASSEMBLY
*3	CAM TIMING OIL CONTROL SOLENOID ASSEMBLY	*4	CRANKSHAFT PULLEY ASSEMBLY
*5	ENGINE MOUNTING BRACKET RH	*6	ENGINE MOUNTING INSULATOR RH
*7	CRANKSHAFT PULLEY BOLT	*8	IGNITION COIL ASSEMBLY
*9	NO. 2 ENGINE COVER	*10	VACUUM PUMP ASSEMBLY
*11	NO. 2 VACUUM SWITCHING VALVE BRACKET	*12	NO. 3 TIMING CHAIN COVER
*13	TIMING GEAR COVER INSULATOR	*14	PLATE WASHER
*15	NO. 1 VACUUM PUMP O-RING	*16	O-RING
	Tightening torque for "Major areas involving basic vehicle performance such as moving/turning/stopping": N*m (kgf*cm, ft.*lbf)		N*m (kgf*cm, ft.*lbf): Specified torque
●	Non-reusable part	★	Precoated part

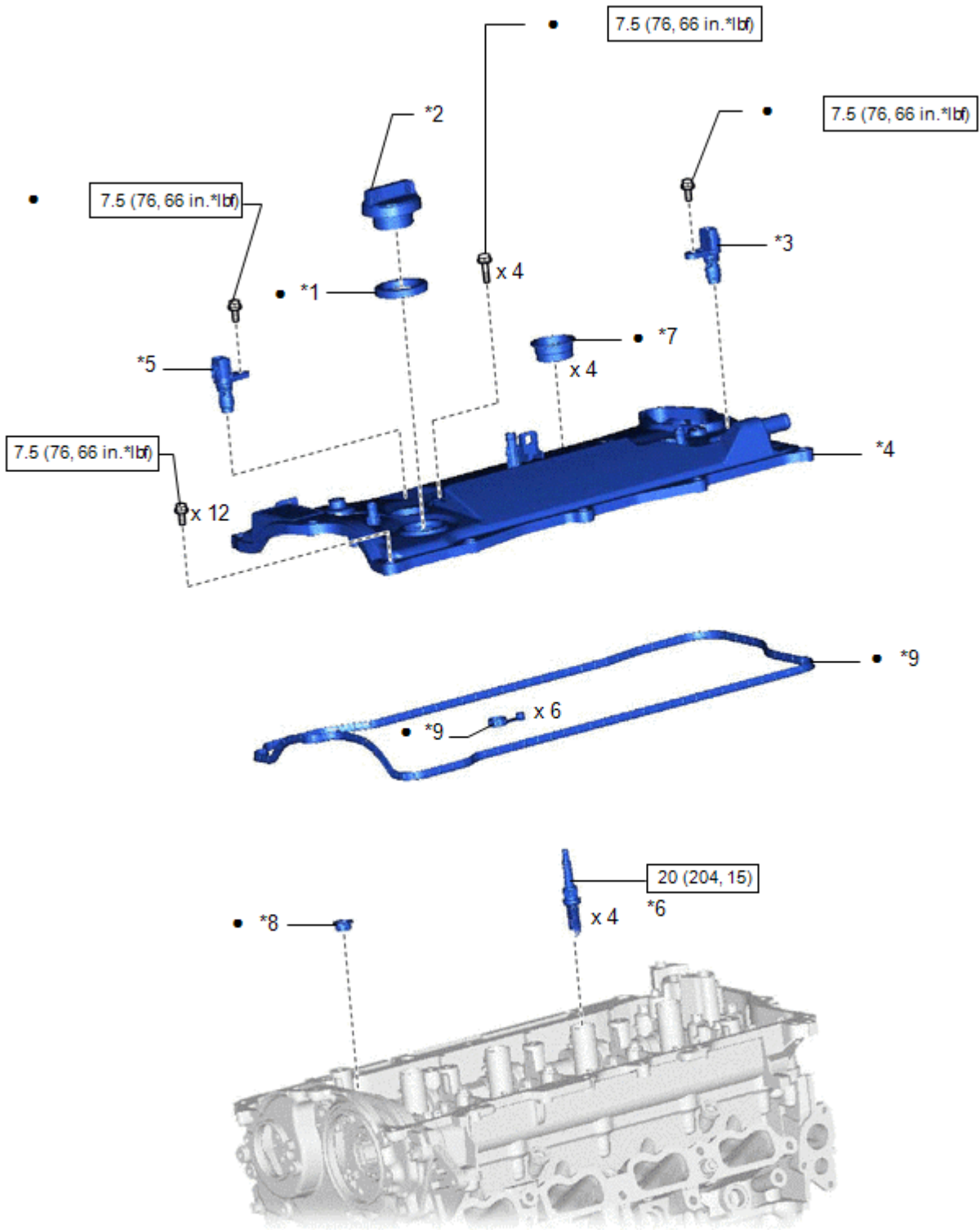



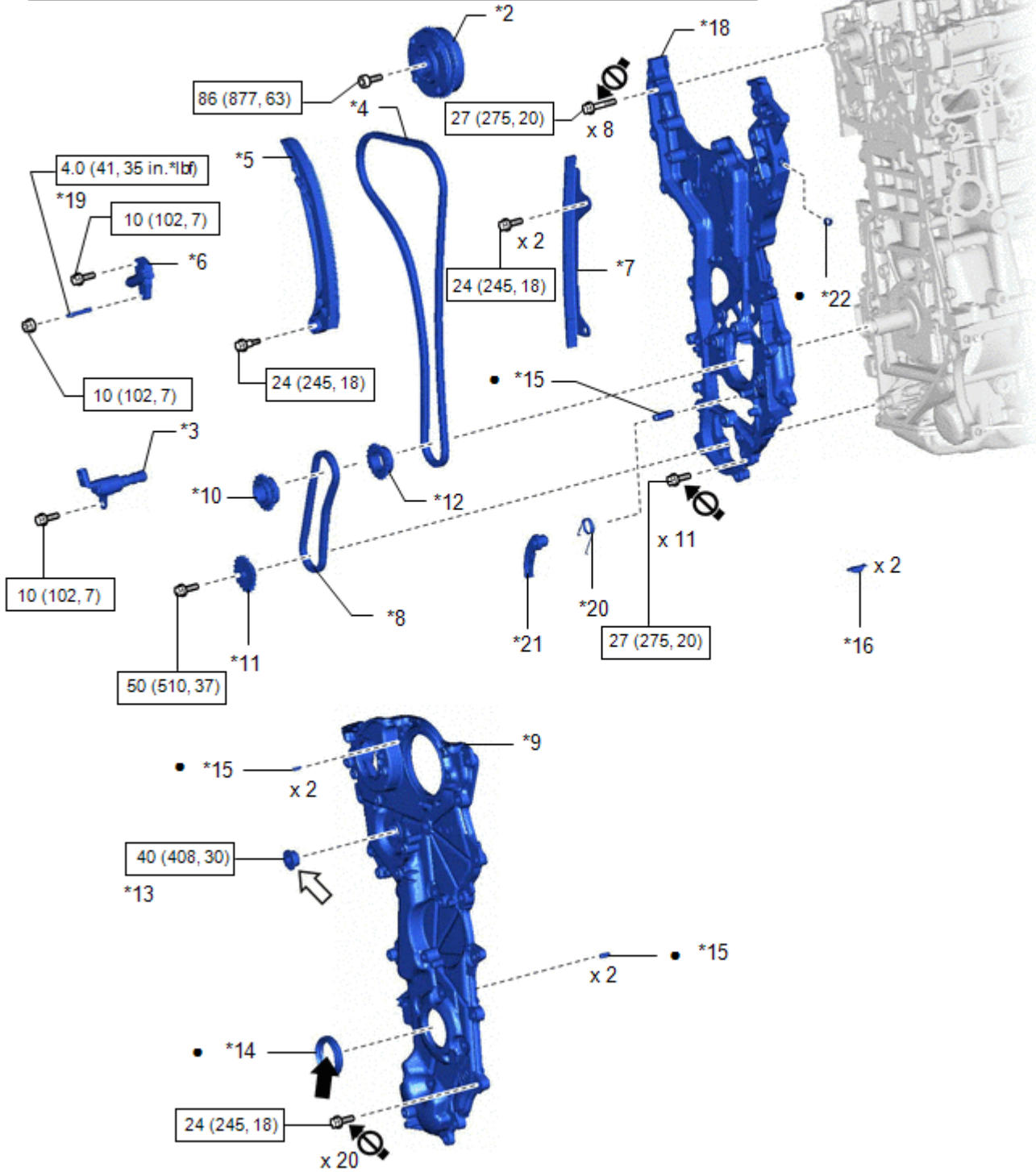
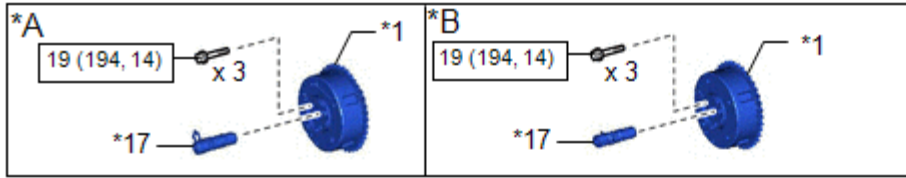

c

(Diagram detail on next page)

*1	OIL FILLER CAP GASKET	*2	OIL FILLER CAP SUB-ASSEMBLY
*3	CAMSHAFT POSITION SENSOR (for Intake Side)	*4	CYLINDER HEAD COVER SUB-ASSEMBLY
*5	CAMSHAFT POSITION SENSOR (for Exhaust Side)	*6	SPARK PLUG
*7	SPARK PLUG TUBE GASKET	*8	CAMSHAFT BEARING CAP OIL HOLE GASKET
*9	CYLINDER HEAD COVER GASKET	-	-
	N*m (kgf*cm, ft.*lbf): Specified torque	•	Non-reusable part
★	Precoated part	-	-



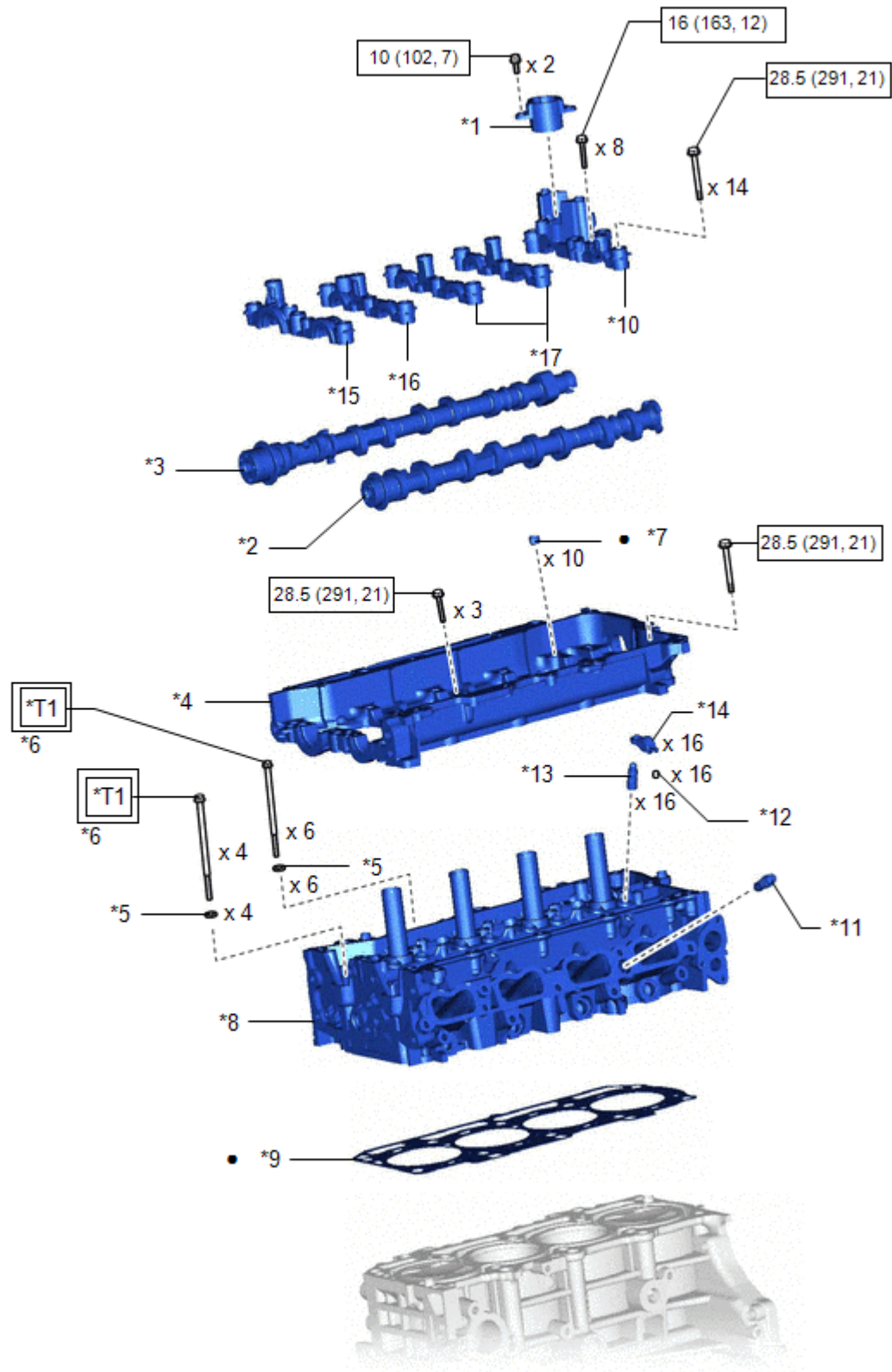

(Diagram detail on next page)

*A	Type A	*B	Type B
*1	CAMSHAFT TIMING EXHAUST GEAR ASSEMBLY	*2	CAMSHAFT TIMING GEAR ASSEMBLY
*3	OIL PRESSURE CONTROL VALVE ASSEMBLY	*4	CHAIN SUB-ASSEMBLY
*5	CHAIN TENSIONER SLIPPER	*6	NO. 1 CHAIN TENSIONER ASSEMBLY
*7	NO. 1 CHAIN VIBRATION DAMPER	*8	OIL PUMP DRIVE CHAIN SUB-ASSEMBLY
*9	NO. 2 TIMING GEAR COVER ASSEMBLY	*10	OIL PUMP DRIVE SPROCKET
*11	OIL PUMP DRIVE SHAFT SPROCKET	*12	CRANKSHAFT TIMING SPROCKET
*13	STRAIGHT SCREW PLUG	*14	TIMING CHAIN COVER OIL SEAL
*15	STRAIGHT PIN	*16	CRANKSHAFT TIMING GEAR KEY
*17	CAMSHAFT TIMING OIL CONTROL VALVE ASSEMBLY (EXHAUST CAMSHAFT TIMING GEAR BOLT ASSEMBLY)	*18	TIMING CHAIN COVER ASSEMBLY
*19	STUD BOLT	*20	CHAIN DAMPER SPRING
*21	CHAIN TENSIONER PLATE	*22	RING PIN
	N*m (kgf*cm, ft.*lbf): Specified torque	•	Non-reusable part
	MP grease		Adhesive 1324
★	Precoated part		Do not apply lubricants to the threaded parts



c



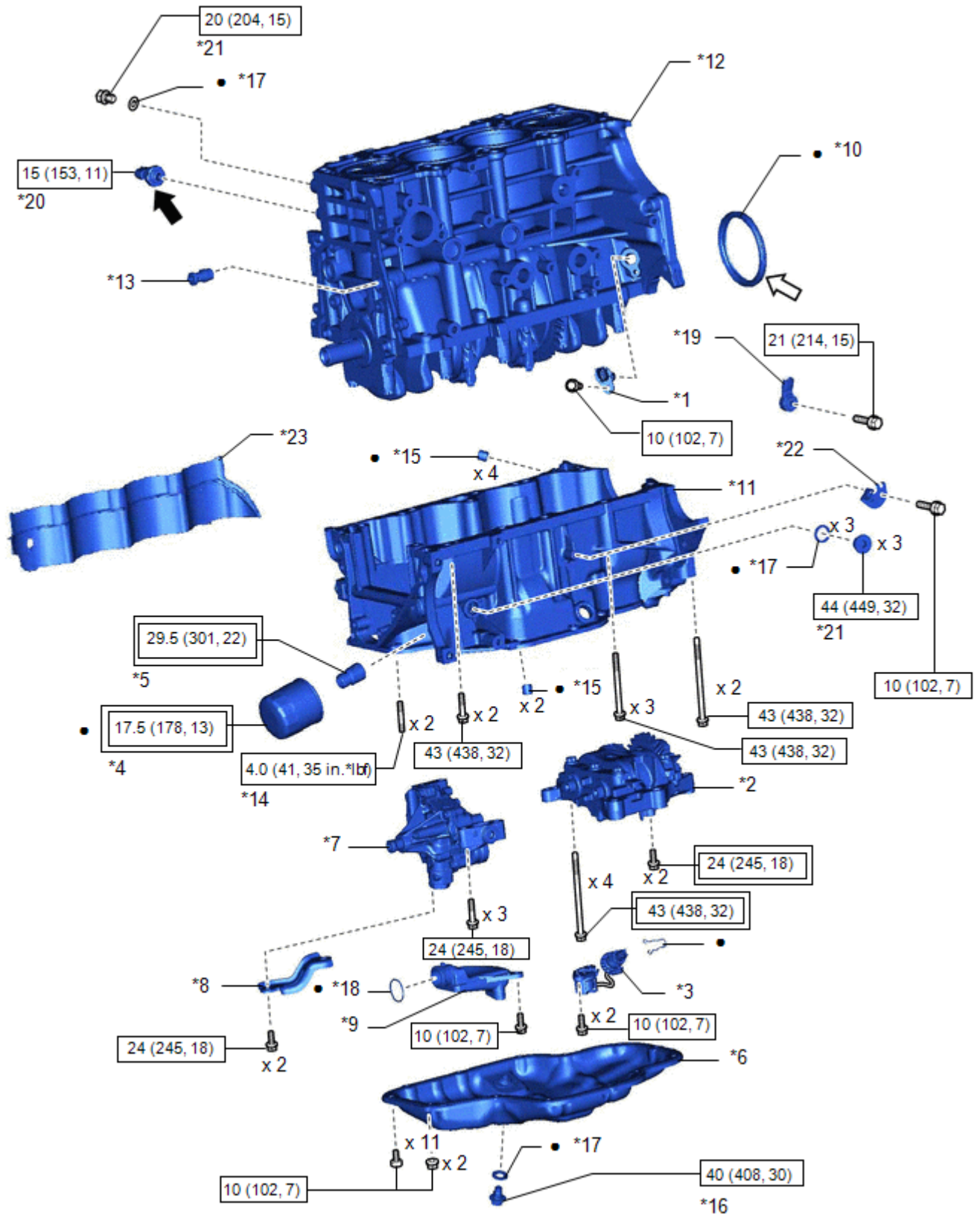

(Diagram detail on next page)

*1	FUEL PUMP LIFTER GUIDE	*2	CAMSHAFT
*3	NO. 2 CAMSHAFT	*4	CAMSHAFT HOUSING SUB-ASSEMBLY
*5	PLATE WASHER	*6	CYLINDER HEAD SET BOLT
*7	CAMSHAFT BEARING CAP SETTING RING PIN	*8	CYLINDER HEAD SUB-ASSEMBLY
*9	CYLINDER HEAD GASKET	*10	NO. 4 CAMSHAFT BEARING CAP
*11	PCV VALVE (VENTILATION VALVE SUB-ASSEMBLY)	*12	VALVE STEM CAP
*13	VALVE LASH ADJUSTER ASSEMBLY	*14	NO. 1 VALVE ROCKER ARM SUB-ASSEMBLY
*15	NO. 1 CAMSHAFT BEARING CAP	*16	NO. 2 CAMSHAFT BEARING CAP
*17	NO. 3 CAMSHAFT BEARING CAP	-	-
	Tightening torque for "Major areas involving basic vehicle performance such as moving/turning/stopping": N*m (kgf*cm, ft.*lbf)		N*m (kgf*cm, ft.*lbf): Specified torque
•	Non-reusable part	-	-
*T1	1st: 90 (918, 66) 2nd: Turn 90° 3rd: Turn 90°	-	-



c

(Diagram detail on next page)

*1	CRANKSHAFT POSITION SENSOR	*2	ENGINE BALANCER ASSEMBLY
*3	ENGINE OIL LEVEL SENSOR	*4	OIL FILTER SUB-ASSEMBLY
*5	OIL FILTER UNION	*6	NO. 2 OIL PAN SUB-ASSEMBLY
*7	OIL PUMP ASSEMBLY	*8	OIL PUMP BRACKET
*9	OIL STRAINER SUB-ASSEMBLY	*10	REAR ENGINE OIL SEAL
*11	STIFFENING CRANKCASE ASSEMBLY	*12	CYLINDER BLOCK SUB-ASSEMBLY
*13	OIL NOZZLE VALVE SUB-ASSEMBLY	*14	STUD BOLT
*15	RING PIN	*16	OIL PAN DRAIN PLUG
*17	GASKET	*18	OIL STRAINER GASKET
*19	KNOCK CONTROL SENSOR	*20	OIL PRESSURE AND TEMPERATURE SENSOR
*21	STRAIGHT SCREW PLUG	*22	WIRE HARNESS CLAMP BRACKET
*23	CYLINDER BLOCK WATER JACKET SPACER	-	-
	Tightening torque for "Major areas involving basic vehicle performance such as moving/turning/stopping": N*m (kgf*cm, ft.*lbf)		N*m (kgf*cm, ft.*lbf): Specified torque
•	Non-reusable part		Adhesive 1344
	MP grease	★	Precoated part

VI. BLOCK ID No. INSPECTION

1. REMOVE CENTER No. 4 ENGINE UNDER COVER

- a. Raise the car on a lift to gain access to the bottom of the vehicle.
- b. Remove the 4 screws to remove the Center No. 4 Engine Under Cover.

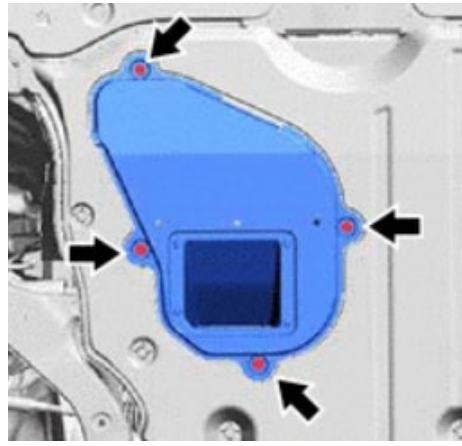

2. LOCATE ENGINE BLOCK ID No.

- a. Reference the photo below to locate the Block ID No. stamping.
- b. Use a clean, wet rag to wipe clean the area of the stamping.

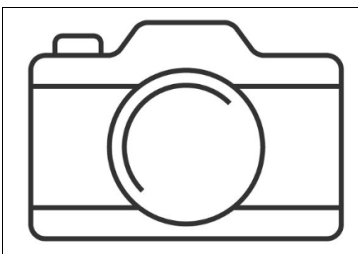
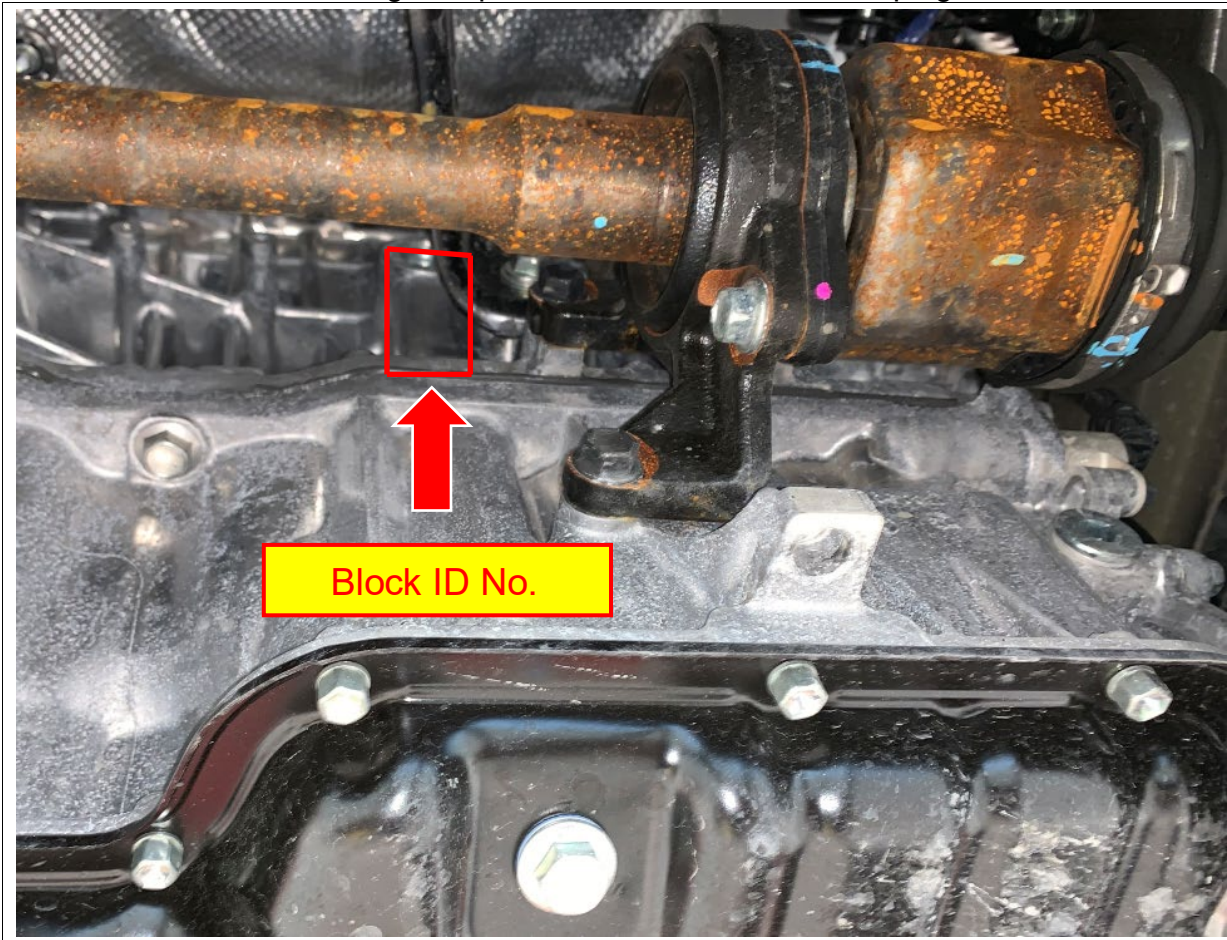

3. TAKE A PHOTO OF THE BLOCK ID No.

- a. Use a digital camera to take a photo of the Block ID No. Be sure to place the camera as straight and level as possible to the surface of the stamping.



4. REVIEW PHOTO

- a. Zoom in on the Block ID No. in the photo to be sure all 12 characters can be clearly read. If all 12 digits are not legible, retake the photo.

5. OPEN INSPECTION WEBSITE

- a. Open the 20TA04 Inspection Website by selecting the following link:

<https://20TA04-20LA02-safety-recall.imagespm.info/>

- b. Enter your dealer code in the User ID field.
- c. Enter xxxxx for the Password. It will then prompt you to change the password. You can enter the same (5 x's) again, or create your own password. If you do change the password, be sure to advise other technicians of the updated password.

Note: Selecting the “Forgot Password” link will reset the password to the default password: xxxxx

- d. Enter the vehicles VIN. It is critical that the VIN be entered accurately.

6. ENTER BLOCK ID No.

- a. Enter the top row of the Block ID No. (6 digits) when prompted.

NOTE: All 6 digits are NUMBERS.



- b. Enter the bottom row of the Block ID No. (6 digits) when prompted.

NOTE: The first digit is a LETTER, the remaining digits are NUMBERS.



Image Upload

Take a photo of the Block ID Number and save to computer. Browse to select the file location and upload.

VIN:

Block ID Number:
 No file chosen

7. UPLOAD PHOTO

- a. The website will require a photo of the Block ID No. to be uploaded. Be sure that all 12 digits of the Block ID No. are legible in the photo.

8. REVIEW INSPECTION RESULTS

- a. Review the results provided by the website after inputting the Block ID No.

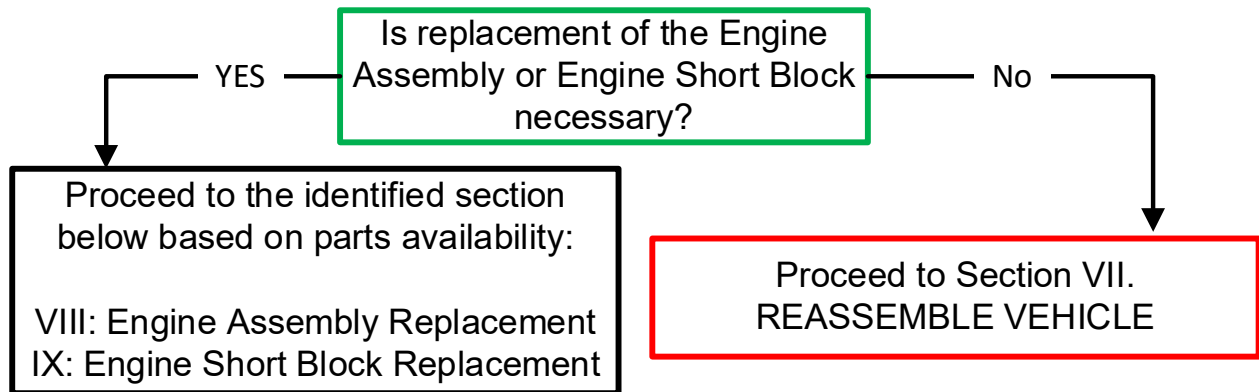

VII. REASSEMBLE VEHICLE (Engine Replacement NOT Necessary)

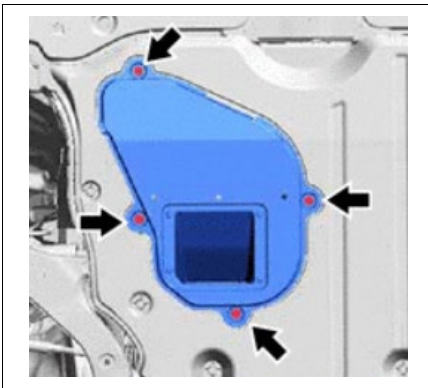

1. INSTALL CENTER No. 4 ENGINE UNDER COVER

- a. Install the center No. 4 engine under cover with the 4 screws.

The Campaign is now complete. Return the vehicle to the customer.

VIII. ENGINE ASSEMBLY REPLACEMENT

**Engine Assembly Replacement is necessary ONLY if directed by the inspection website and an Engine Assembly IS available.
DO NOT perform this procedure unless directed.**

1. REMOVE ENGINE & TRANSMISSION FROM VEHICLE

- Follow the Repair Manual Process to remove the engine from the vehicle.

[A25A-FKS \(ENGINE MECHANICAL\): ENGINE ASSEMBLY: REMOVAL; 2020 MY Camry](#)

2. UPDATE ENGINE SERIAL NUMBER

- Send an email to quality_compliance@toyota.com with the following information:
 - Subject: J0M Engine Serial Number Update
 - Vehicle Identification Number (VIN)
 - Serial Number from the ORIGINAL engine
 - Serial Number from the **NEW** engine

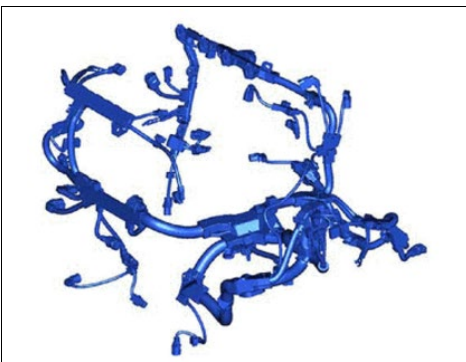
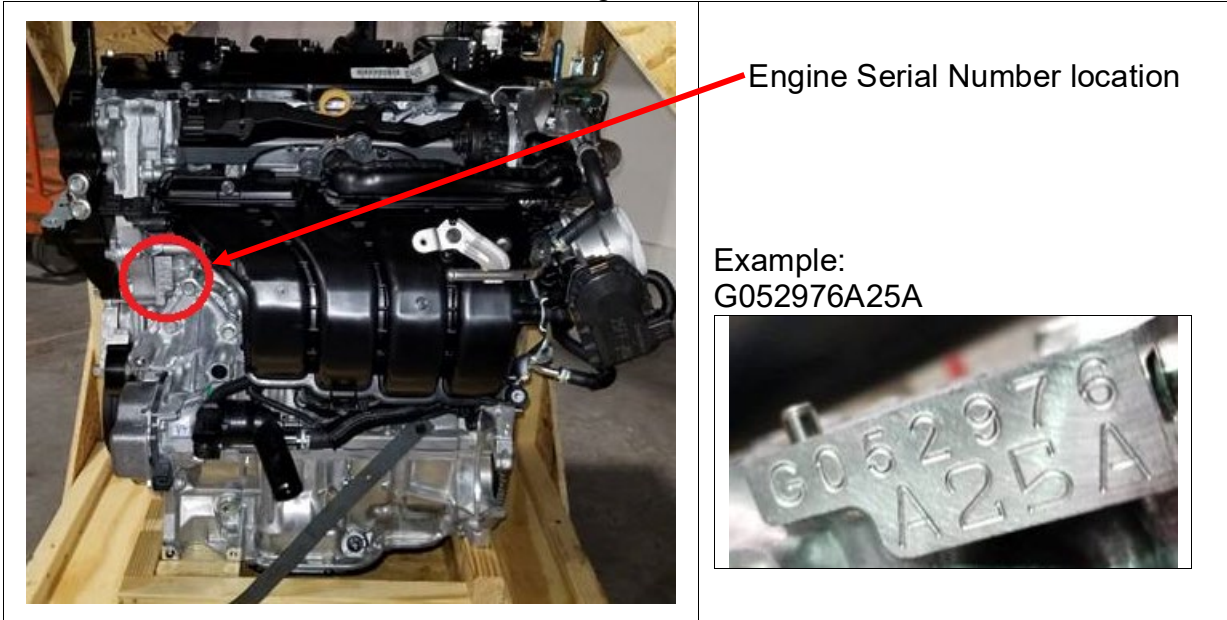

3. REMOVE ENGINE MAIN HARNESS

- Remove the engine main harness from the original engine.

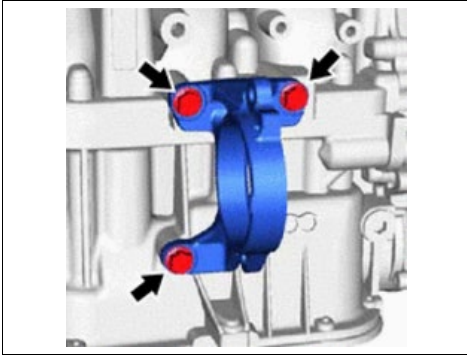

4. TRANSFER DRIVE SHAFT BEARING BRACKET

- a. Remove the 3 bolts and drive shaft bearing bracket from the original engine.
- b. Install the drive shaft bearing bracket and 3 bolts onto the **NEW** engine.

Torque: 47 lbf.ft {63.7 N·m, 650 kgf·cm}

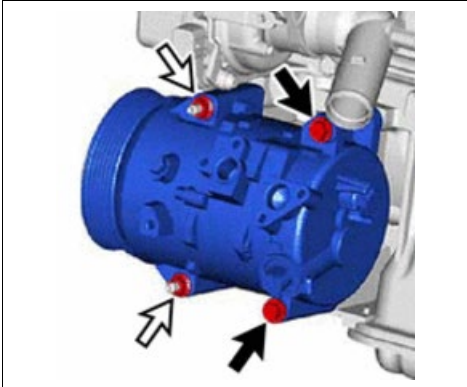

5. TRANSFER COMPRESSOR ASSEMBLY (with stud bolts)

- a. Remove the 2 bolts and 2 nuts from the original engine.

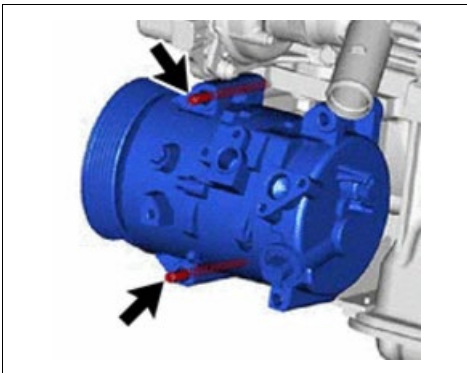

- b. Using a E8 "TORX" wrench, remove the 2 stud bolts and compressor assembly.
- c. Install the 2 stud bolts onto the **NEW** engine.

Torque: 7 lbf.ft {10 N·m, 102 kgf·cm}

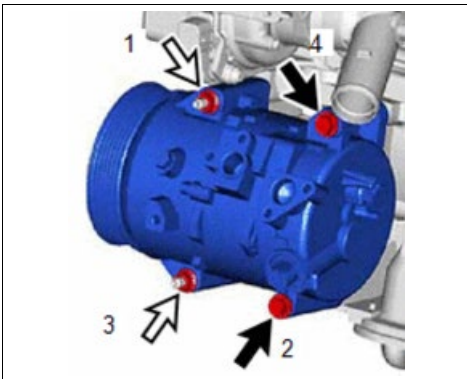

- d. Install the compressor assembly onto the NEW engine with the 2 bolts and 2 nuts. Torque in the sequence shown.

Torque: 18 lbf.ft {24.5 N·m, 250 kgf·cm}

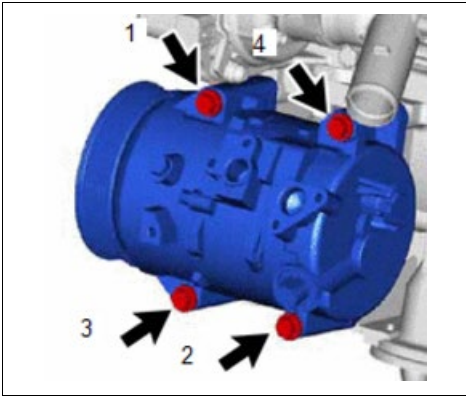

- 6. TRANSFER COMPRESSOR ASSEMBLY (bolts only)**
- Remove the 4 bolts and compressor assembly from the original engine.
 - Install the compressor assembly and 4 bolts onto the **NEW** engine. Torque in the sequence shown.
- Torque: 18 lbf.ft {24.5 N·m, 250 kgf·cm}**

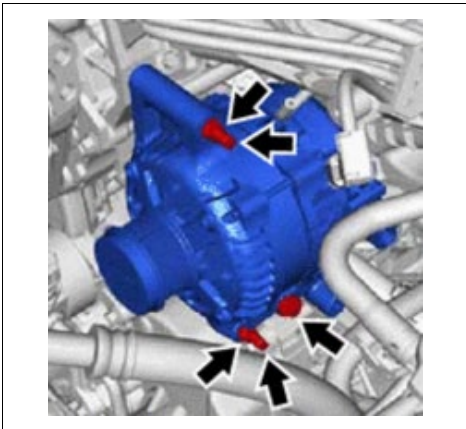

- 7. TRANSFER GENERATOR ASSEMBLY**
- Remove the 2 nuts and bolt from the original engine.
 - Using a E8 "TORX" wrench, remove the 2 studs.
 - Install the 2 studs onto the **NEW** engine.
- Torque: 87 lbf.in {9.8 N·m, 100 kgf·cm}**
- Install the original generator onto the **NEW** engine.
 - Install the 2 nuts and bolt.
- Torque: 18 lbf.ft {25 N·m, 255 kgf·cm}**

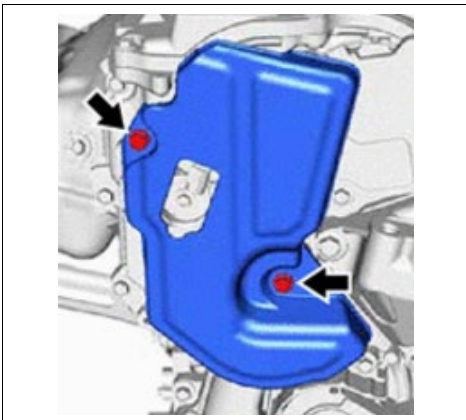

- 8. TRANSFER NO. 2 ENGINE COVER**
- Remove the 2 bolts and cover
 - Install the cover and 2 bolts onto the **NEW** engine.
- Torque: 7 lbf.ft {10 N·m, 102 kgf·cm}**

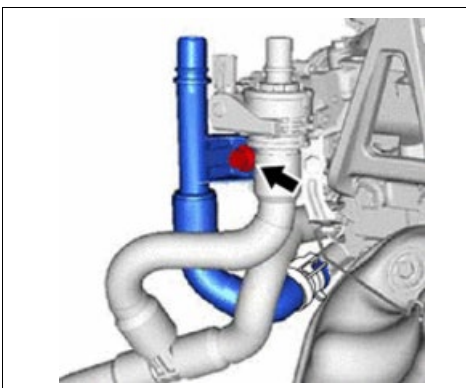

- 9. TRANSFER NO. 2 WATER BY-PASS PIPE**
- Remove the bracket bolt from the original engine.
 - Slide the clamp and remove the hose.
 - Install the hose and clamp onto the **NEW** engine.
 - Install the bracket bolt.
- Torque: 14 lbf.ft {19 N·m, 194 kgf·cm}**

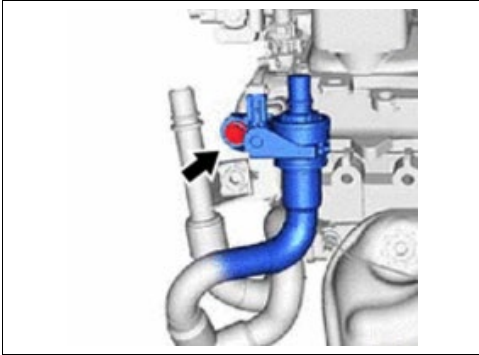

10. TRANSFER FLOW SHUTTING VALVE

a. Remove the bolt from the original engine.

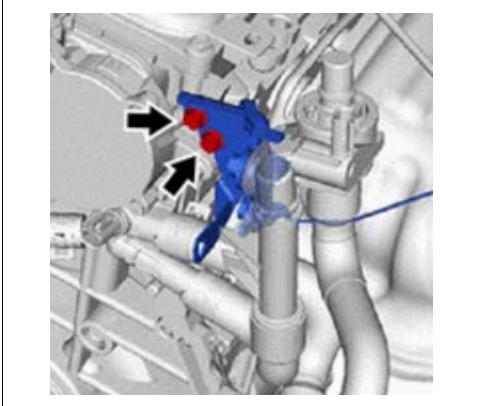

b. Remove the 2 bolts and the water hose bracket.

c. Remove the clamp and hose from the original engine.

d. Install the hose onto the water outlet of the **NEW** engine.

e. Install the bracket onto the **NEW** engine with the 2 bolts.

Torque: 10 lbf.ft {13 N·m, 133 kgf·cm}

f. Install the valve to the bracket.

Torque: 14 lbf.ft {19 N·m, 194 kgf·cm}



11. TRANSFER EXHAUST MANIFOLD

a. Remove the 5 bolts from the heat insulator.

b. Remove the manifold stay on the bottom.

c. Using a 12mm deep socket, remove the 7 nuts and separate the exhaust manifold.

Note: Discard the 7-exhaust manifold nut's as they will not be reused.

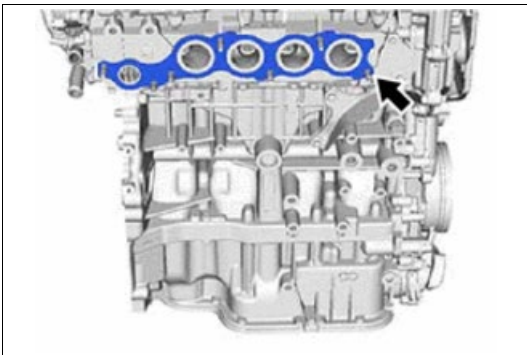

d. Install a **NEW** exhaust manifold gasket onto the **NEW** engine.

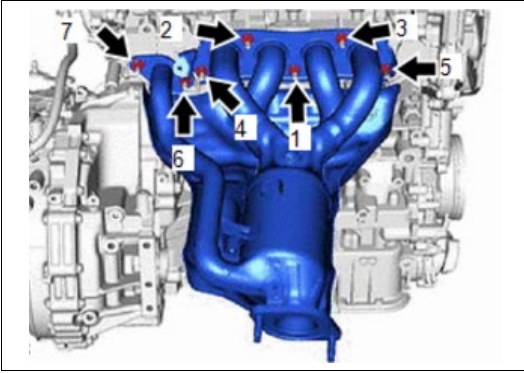

- e. Install the exhaust manifold onto the **NEW** engine.
- f. Temporarily install the 7 **NEW** nuts onto the studs.
- g. Using a 12mm deep socket, torque the 7 nuts in the sequence shown.

Torque: 19 lbf.ft {26 N·m, 265 kgf·cm}

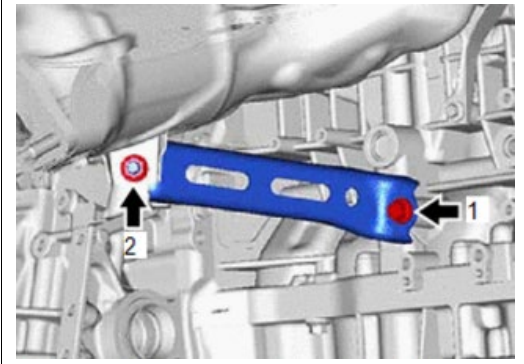

- h. Install the manifold stay and the nut and bolt.
- i. Torque the nut and bolt in the sequence shown

Torque: 32 lbf.ft {43 N·m, 438 kgf·cm}

- j. Install the heat insulator with the 5 bolts.

Torque: 7 lbf.ft {10 N·m, 102 kgf·cm}

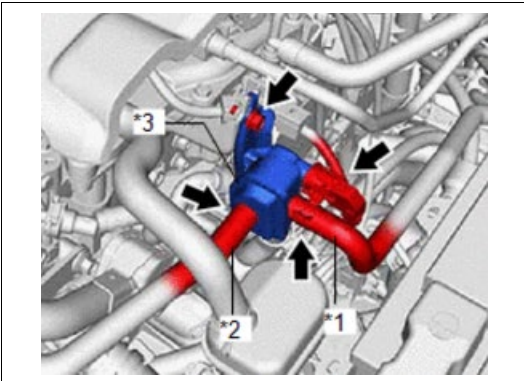

12. TRANSFER PURGE VALVE

- a. Unbolt the purge valve from the mounting bracket on the original engine.
- b. Disconnect the hoses at the other end (opposite the purge valve)
- c. Install the purge valve on the **NEW** engine, attaching the hoses properly. Install the bolt to the mounting bracket.

Torque: 7 lbf.ft {10 N·m, 102 kgf·cm}

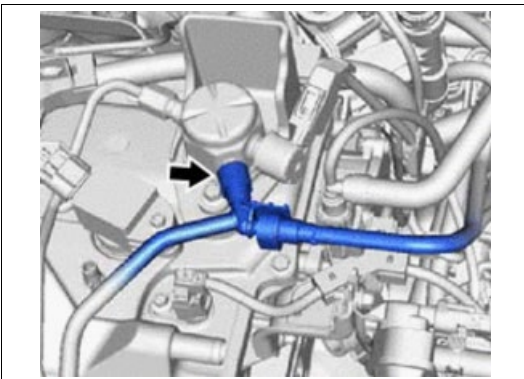

13. TRANSFER FUEL TUBE

- a. Disconnect the fuel tube at the high-pressure fuel pump of the original engine.

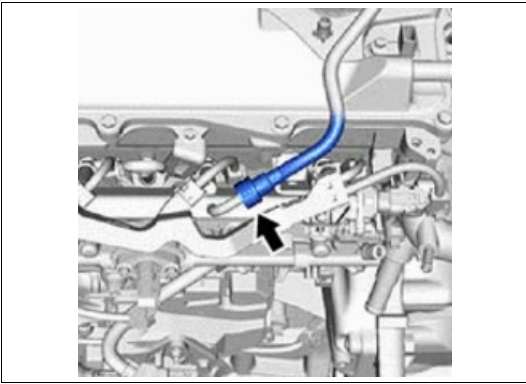

- b. Disconnect the fuel tube at the low-pressure fuel rail of the original engine.
- c. Install the fuel tube to both the low-pressure fuel rail and the high-pressure pump of the **NEW** engine.

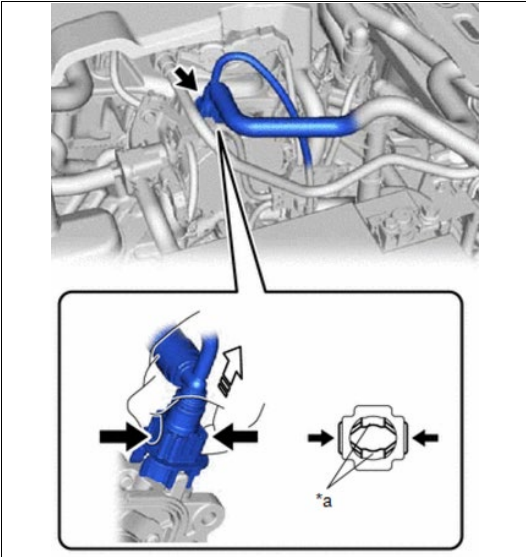

14. TRANSFER No. 1 VACUUM PUMP HOSE

- a. Pinch the retainer of the No. 1 vacuum hose connector, then pull the connector off the vacuum pump assembly.
- b. Install the No. 1 vacuum pump hose onto the **NEW** engine.

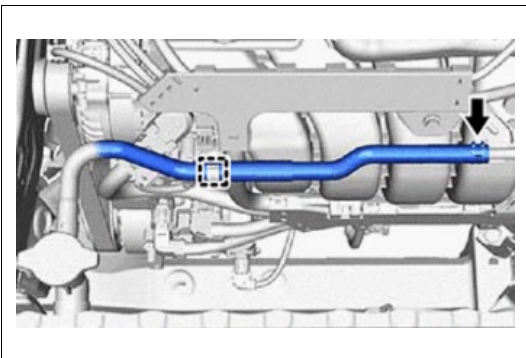

15. TRANSFER No. 5 WATER BYPASS HOSE

- a. Remove the No. 5 water bypass hose from the original engine.
- b. Install the No. 5 water bypass hose onto the **NEW** engine.

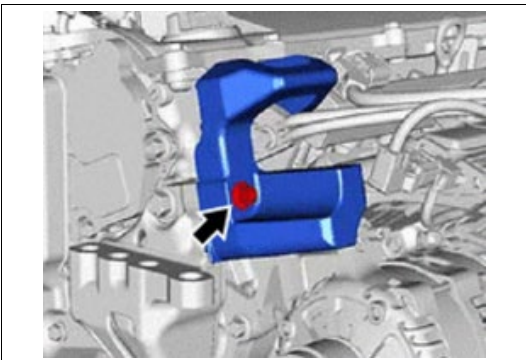

16. TRANSFER FUEL DELIVERY GUARD

- a. Remove the bolt and fuel delivery guard from the original engine.
- b. Install the fuel delivery guard and bolt onto the **NEW** engine.

Torque: 30 lbf.ft {40 N·m, 408 kgf·cm}

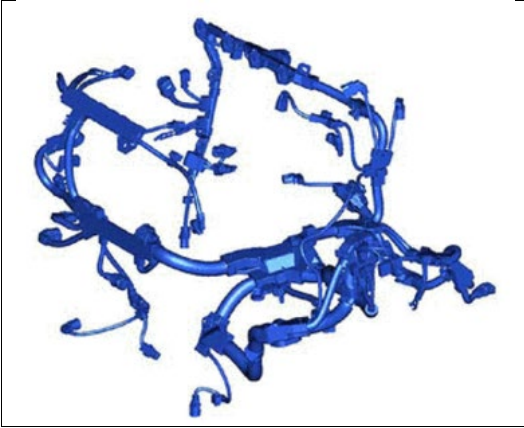

17. INSTALL ENGINE MAIN HARNESS

- a. Install the engine main harness onto the **NEW** engine.

18. REMOVE AUTOMATIC TRANSMISSION ASSEMBLY FROM ORIGINAL ENGINE

- a. Follow the Repair Manual Process to separate the engine and transmission.

UA80E (AUTOMATIC TRANSMISSION / TRANSAXLE): AUTOMATIC
TRANSAXLE ASSEMBLY: REMOVAL; 2019 - 2020 MY Camry

19. INSTALL AUTOMATIC TRANSMISSION ASSEMBLY TO **NEW** ENGINE

- a. Follow the Repair Manual Process to join the engine and transmission together

UA80E (AUTOMATIC TRANSMISSION / TRANSAXLE): AUTOMATIC
TRANSAXLE ASSEMBLY: INSTALLATION; 2019 - 2020 MY Camry

20. INSTALL **NEW** ENGINE & TRANSMISSION INTO VEHICLE

- a. Follow the Repair Manual Process to install the engine into the vehicle.

A25A-FKS (ENGINE MECHANICAL): ENGINE ASSEMBLY: INSTALLATION;
2019 - 2020 MY Camry

◀ VERIFY REPAIR QUALITY ▶

- Verify all DTC's have been cleared.
- Verify the air cleaner cap and hose are properly installed.
- Verify there are no oil or coolant leaks.
- Test drive the vehicle to confirm normal operation.

If you have any questions regarding this update, please contact your regional representative.

IX. ENGINE SHORT BLOCK REPLACEMENT

Engine Short Block Replacement is necessary ONLY if directed by the inspection website and an Engine Assembly IS NOT available.

DO NOT perform this procedure unless directed.

1. REMOVE ENGINE & TRANSMISSION FROM VEHICLE

- a. Follow the Repair Manual Process to remove the engine from the vehicle.

[A25A-FKS \(ENGINE MECHANICAL\): ENGINE ASSEMBLY: REMOVAL; 2020 MY Camry](#)

2. UPDATE ENGINE SERIAL NUMBER

- a. Send an email to quality_compliance@toyota.com with the following information:
 - Subject: 20TA04 Engine Serial Number Update
 - Vehicle Identification Number (VIN)
 - Serial Number from the ORIGINAL engine
 - Serial Number from the **NEW** engine short block

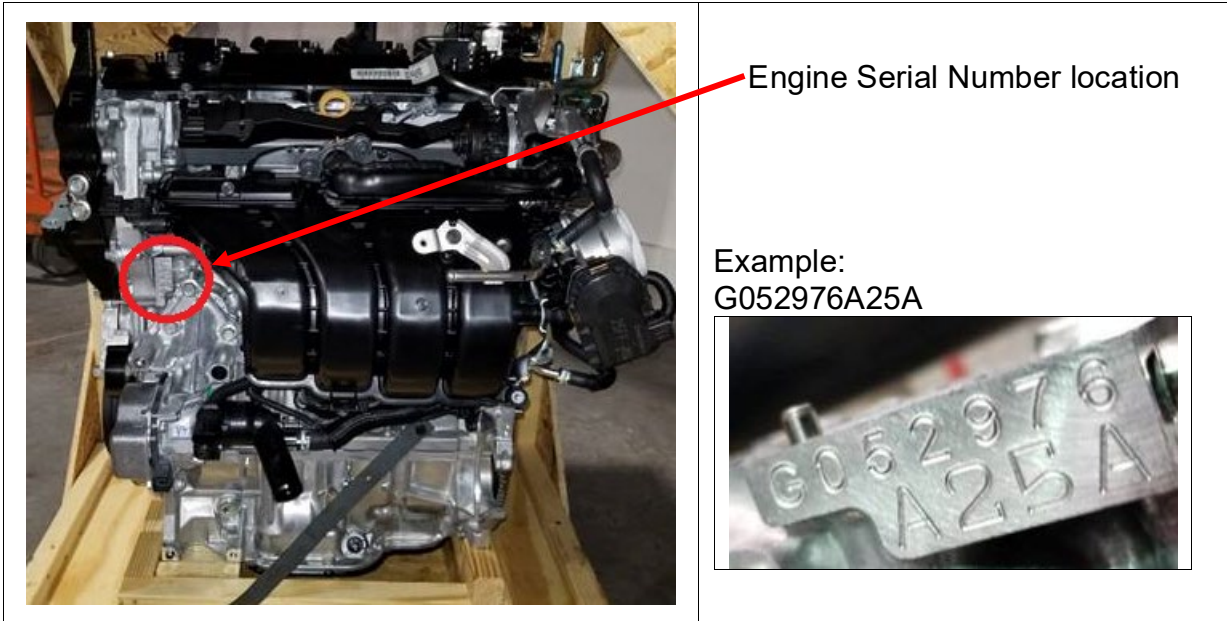

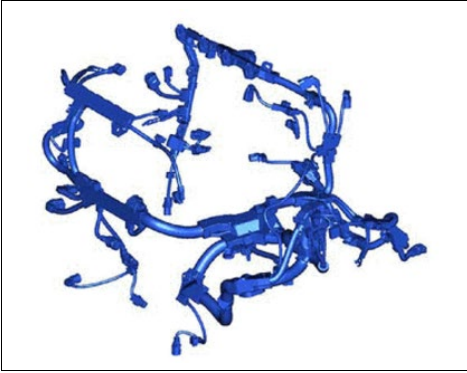

3. REMOVE ENGINE MAIN HARNESS

- a. Remove the engine main harness from the original engine.

4. REMOVE ENGINE UNIT

- a. Follow the Repair Manual Process to remove the engine unit.

[A25A-FKS \(ENGINE MECHANICAL\): ENGINE UNIT: REMOVAL; 2020 MY Camry](#)

5. REMOVE AUTOMATIC TRANSMISSION ASSEMBLY FROM **ORIGINAL** ENGINE

- a. Follow the Repair Manual Process to separate the engine and transmission.

[UA80E \(AUTOMATIC TRANSMISSION / TRANSAXLE\): AUTOMATIC TRANSAXLE ASSEMBLY: REMOVAL; 2019 - 2020 MY Camry](#)

6. DISASSEMBLE ENGINE COMPONENTS FROM **ORIGINAL** SHORT BLOCK

- a. Follow the Repair Manual Process to disassemble the engine unit.

[A25A-FKS \(ENGINE MECHANICAL\): ENGINE UNIT: DISASSEMBLY; 2020 MY Camry](#)

7. REASSEMBLE ENGINE COMPONENTS TO **REPLACEMENT** SHORT BLOCK

- a. Follow the Repair Manual Process to reassemble the engine unit.

[A25A-FKS \(ENGINE MECHANICAL\): ENGINE UNIT: REASSEMBLY; 2020 MY Camry](#)

8. INSTALL AUTOMATIC TRANSMISSION ASSEMBLY TO **REBUILT** ENGINE

- a. Follow the Repair Manual Process to join the **REBUILT** engine and transmission together

[UA80E \(AUTOMATIC TRANSMISSION / TRANSAXLE\): AUTOMATIC TRANSAXLE ASSEMBLY: INSTALLATION; 2019 - 2021 MY Camry](#)

9. INSTALL ENGINE UNIT

- a. Follow the Repair Manual Process to remove the engine unit.

[A25A-FKS \(ENGINE MECHANICAL\): ENGINE UNIT: INSTALLATION; 2020 MY Camry](#)

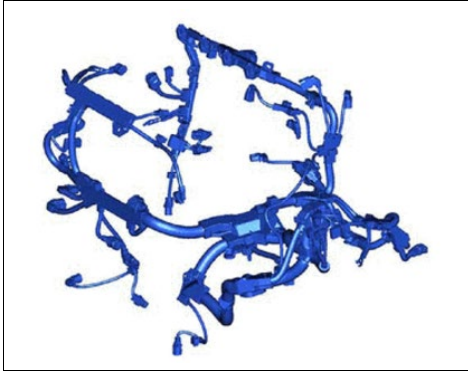

10. INSTALL ENGINE MAIN HARNESS

- a. Install the engine main harness on the **REBUILT** engine.

11. INSTALL **REBUILT** ENGINE & TRANSMISSION INTO VEHICLE

- a. Follow the Repair Manual Process to install the **REBUILT** engine into the vehicle.

A25A-FKS (ENGINE MECHANICAL): ENGINE ASSEMBLY: INSTALLATION; 2019 - 2020 MY Camry

◀ VERIFY REPAIR QUALITY ▶

- Verify all DTC's have been cleared.
- Verify the air cleaner cap and hose are properly installed.
- Verify there are no oil or coolant leaks.
- Test drive vehicle to confirm normal operation.

If you have any questions regarding this update, please contact your area representative.

X. APPENDIX

A. PARTS DISPOSAL

As required by Federal Regulations, please make sure all recalled parts (original parts) removed from the vehicle are disposed of in a manner in which they will not be reused, ***unless requested for parts recovery return.***

19TA01

19

Year Campaign
is Launched

19 = 2019
20 = 2020
21 = 2021
22 = 2022
23 = 2023
Etc...

T

Vehicle Make

T = Toyota
L = Lexus

A

Field Action Category and Phase

A = Safety Recall *Remedy*
B = Safety Recall *Interim*
C = Special Service Campaign
D = Limited Service Campaign
E = Customer Support Program
F = Emissions Recall
(May use other characters in unique cases)

01

Field Action Sequence

01 = 1st Field Action of the year
02 = 2nd Field Action of the year
03 = 3rd Field Action of the year

(The sequence is unique for each
Field Action category)
(May use other characters in
unique cases)