



SAFETY RECALL BULLETIN

SUBJECT:		No: SR-20-001REV
DRIVER SIDE TAKATA NADI INFLATOR – SAFETY RECALL CAMPAIGN		DATE: June 2021
		MODEL: 1998–2000 Montero
CIRCULATE TO:	<input type="checkbox"/> GENERAL MANAGER	<input checked="" type="checkbox"/> PARTS MANAGER
	<input checked="" type="checkbox"/> SERVICE ADVISOR	<input checked="" type="checkbox"/> SERVICE MANAGER
	<input checked="" type="checkbox"/> WARRANTY PROCESSOR	<input checked="" type="checkbox"/> SALES MANAGER
		<input checked="" type="checkbox"/> TECHNICIAN

This bulletin supersedes SR-20-001 issued February 2021, to update the Squib Harness Modification section of the Installation Process. Revisions are italicized and indicated by: ◀

PURPOSE

This campaign bulletin instructs dealers to replace the Takata Non-Azide Driver air bag Inflator (NADI) with the countermeasure part.

BACKGROUND

A population of NADI (non-azide driver inflators) manufactured between May 1995 and March 1999 may absorb moisture, causing the inflators to rupture or the airbag cushion to underinflate in vehicle collisions involving airbag deployment, increasing the risk of serious injury or death.

AFFECTED VEHICLES

Certain 1998 - 2000 Montero vehicles

IMPORTANT

Affected new or used inventory vehicles must be repaired before the vehicle is delivered. Dealers must check their inventory vehicles' VINs on the Warranty Superscreen to verify whether the vehicle is involved in this recall campaign. It is a violation of Federal law for a dealer to deliver a new motor vehicle or any new or used item of motor vehicle equipment (including a tire) covered by the notification under a sale or lease until the defect or noncompliance is remedied.

CUSTOMER NOTIFICATION

A letter will be sent to all owners of affected vehicles telling them to visit their local Authorized Mitsubishi Motors dealer to have the passenger side front air bag inflator replaced. A **sample** customer notification letter appears at the end of this bulletin.

REQUIRED OPERATIONS

Before starting this campaign procedure, **CHECK THE WARRANTY SUPERSCREEN** to verify if the vehicle is an affected VIN for this campaign and confirm if this campaign procedure has not already been completed.

WORK FLOW

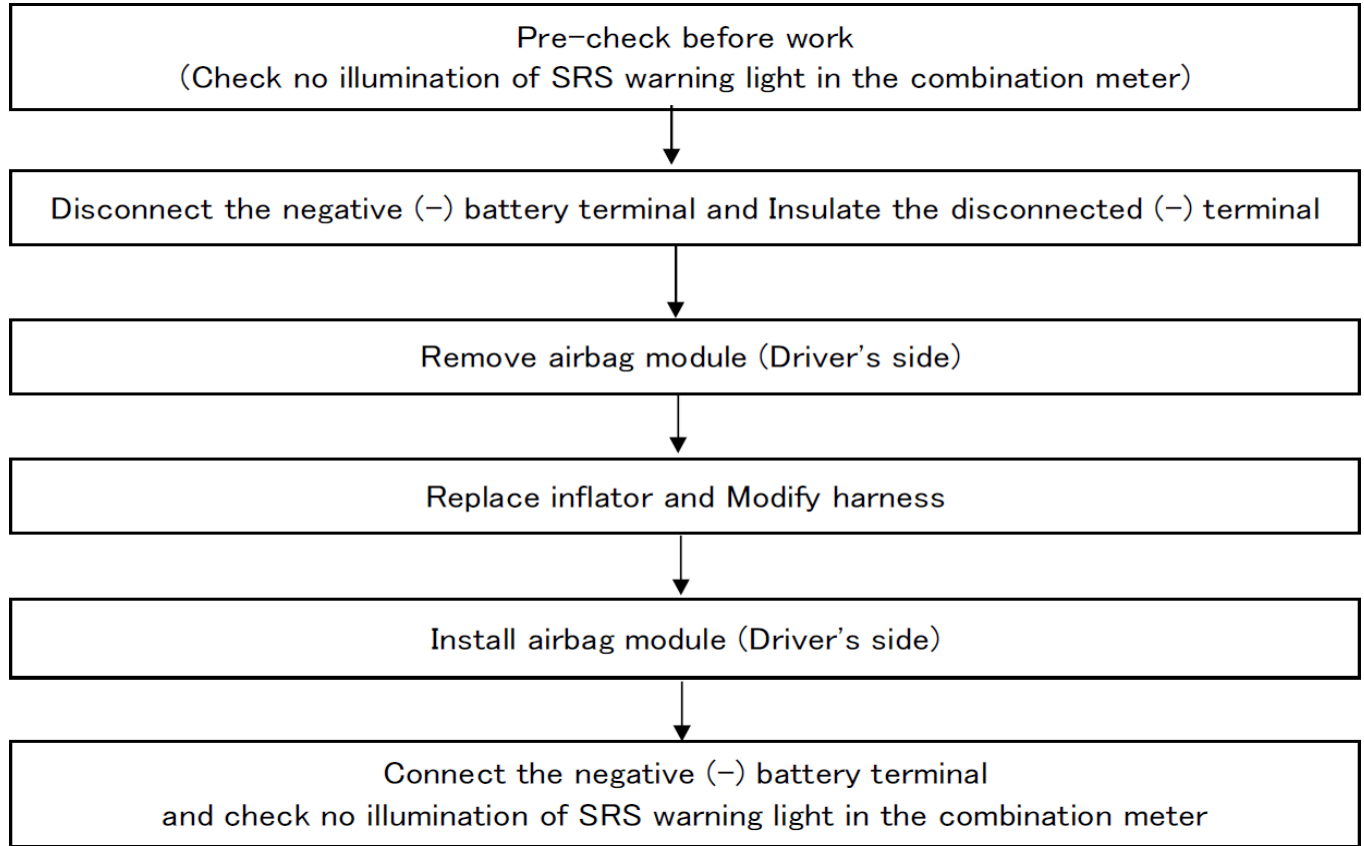

REPAIR PROCEDURE

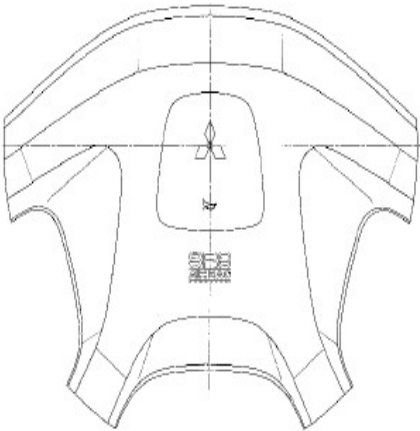
Applicable part	MR307479 (Airbag module)
	<p>This work procedure describes replacement step of the inflator kit which is installed in this driver's airbag module.</p>

INFLATOR REMOVAL PROCESS

1. Preparation

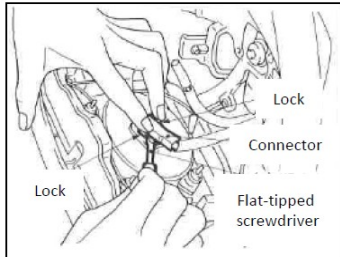
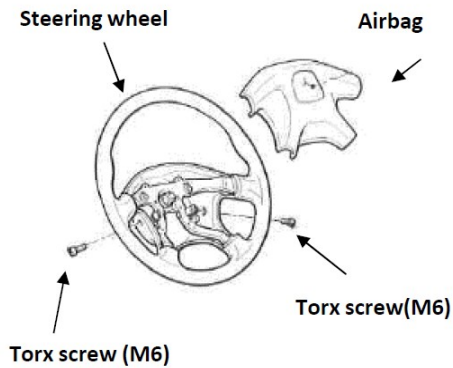

1. Airbag module removal

- (1) Loosen 2 torx screws (T30) and release lock of airbag module.
- (2) While lifting up airbag module and pushing out connector locks (described in left figure), disconnect squib harness connector using flat-tipped screwdriver.
- (3) Remove horn harness.

CAUTION

- Make sure the SRS warning light is not illuminated on the combination meter.
- If illuminated, perform necessary diagnosis/repair before recall work.
- Record customer setting information of Audio, Clock etc.
- Disconnect the negative (-) battery terminal and wait for 60 seconds or more before starting work.
- Insulate the disconnected (-) terminal by wrapping the tape.

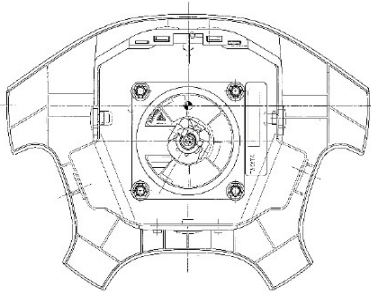

2. Place the airbag module on a work bench covered with a clean cloth/sheet.

Place the airbag module onto the cloth/sheet facing down.

CAUTION

Airbag module must be protected from scratch, adhesive, dirt, dust & sharp tools.

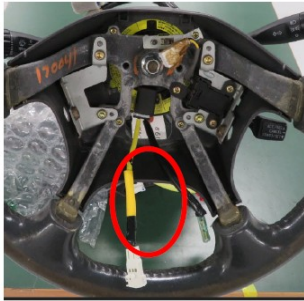

3. Condition after removal of airbag module as left figure

This Squib harness (left figure: red circle part) will be modified in next steps

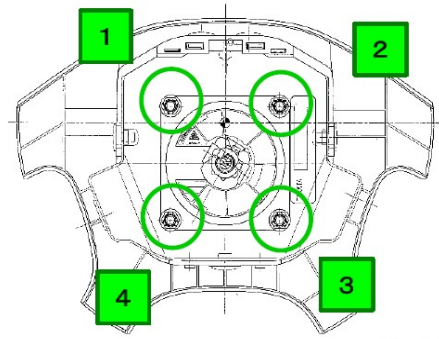
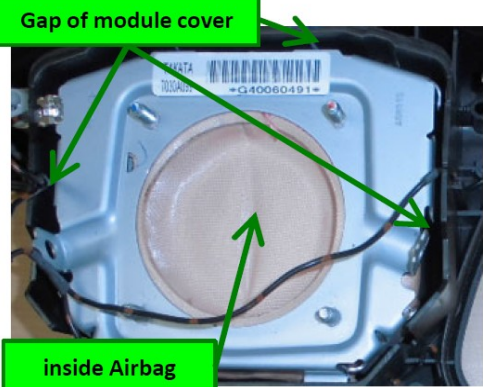
<p>2. Inflator removal</p>	
 	<p>1. Remove 4 nuts (M6) securing the inflator.</p> <p>CAUTION</p> <p>These 4 nuts are unusable. Mark the 4 nuts removed to prevent reuse by mistake.</p>
	<p>2. Remove the inflator.</p> <p>CAUTION</p> <ul style="list-style-type: none"> - Do not drop the removed nuts into the air bag or into the gap of the module cover. - If dropped , remove them securely. - Check that there are 4 nuts after the completion of work. - Do not reuse nuts.

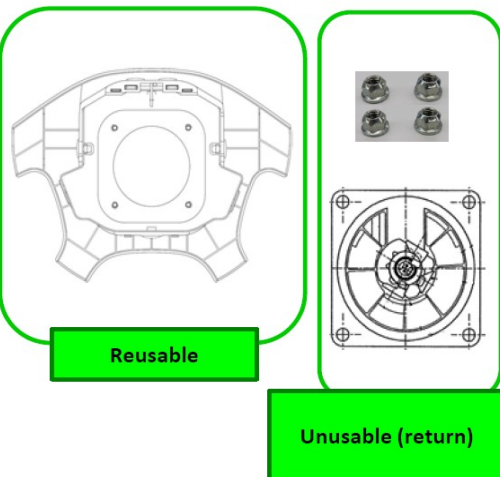
<p>3. Completion of removing parts</p>	
	<p>1. Check all removed parts are available (not scrapped)</p> <p>2. Old inflator, 4 nuts and cut squib harness (instructed in next page)</p> <p>All of these parts must be returned within the same box the new inflator kit were contained</p> <p>CAUTION</p> <ul style="list-style-type: none"> - Place the old inflator and removed parts in the same replacement kit packaging. - Do not mix up with other inflator packaging.

INFLATOR INSTALLATION PROCESS

1. Install new inflator to airbag module

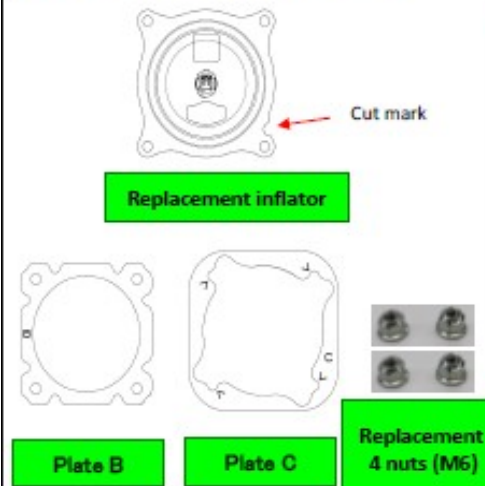

1. Take out the inflator and plates B, C and 4 nuts from new inflator kit box.

Installation process

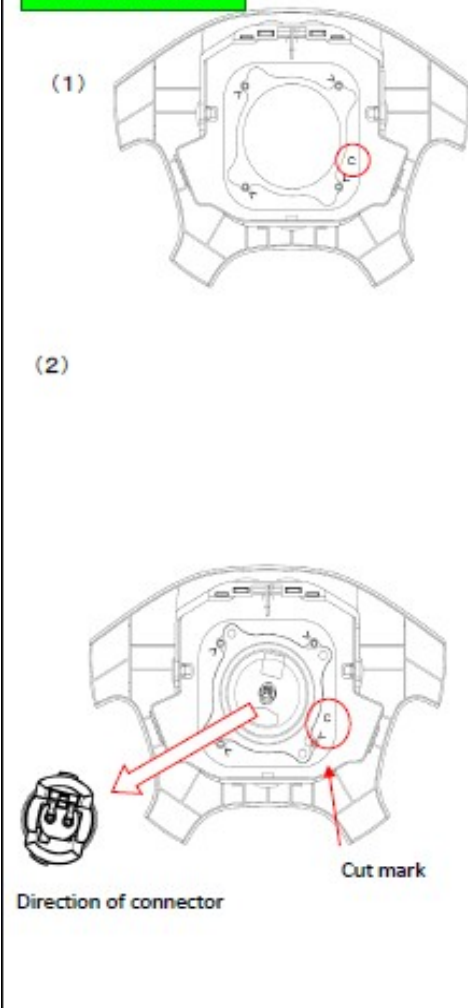

2. Installation process

(1) Install plate C on the reused air bag module

The "C" mark must be at the position of right bottom (as shown in the left figure).

(2) Insert new inflator into the inner guide of plate C.

See images below for proper installation of the inflator.

Check the direction of the inflator connector as shown below.

Inflator and Connector slightly angled and fitted into plate C:

Correct

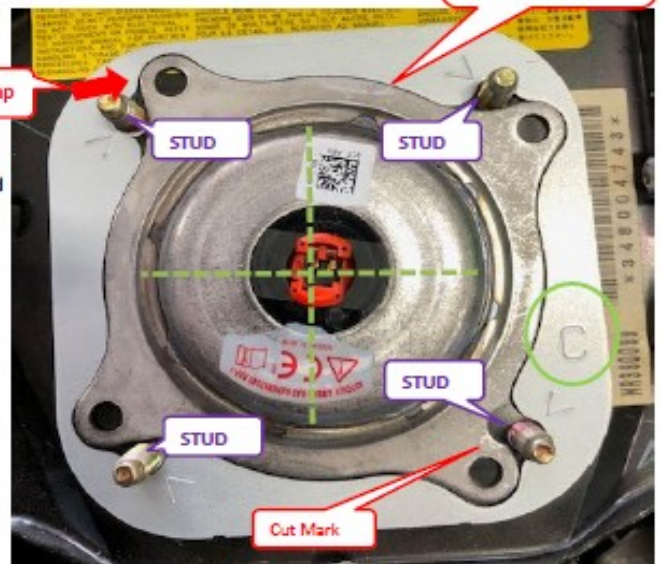

Inflator and Connector
straight up and
overlapping plate C:
Incorrect

NOTE:
4 studs **DO NOT** go
through 4 holes in the
inflator.

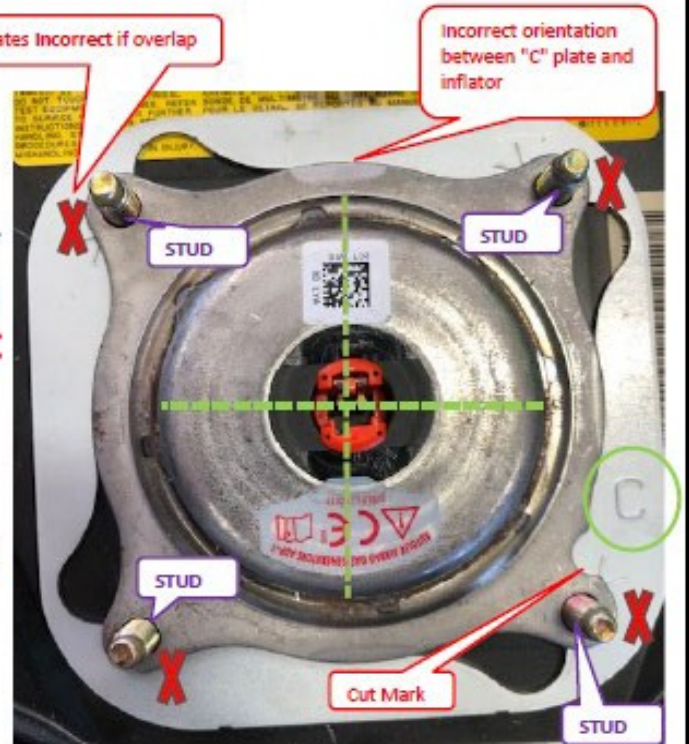

(3) Install plate B

The "B" mark must be at the position of middle left (as shown in the left figure and image below).

(3)

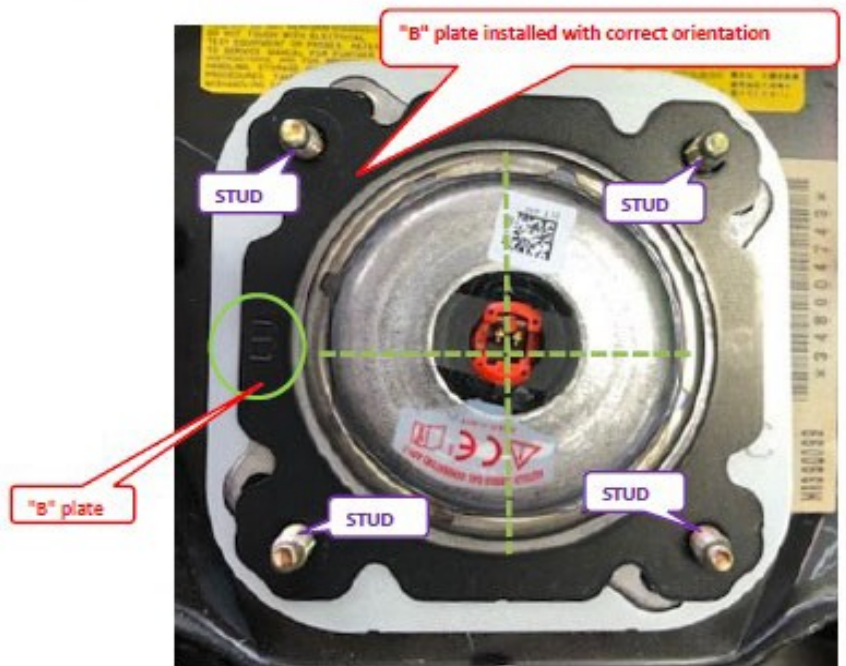
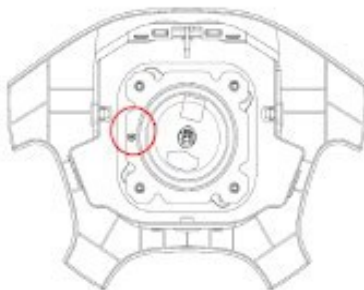

(4)

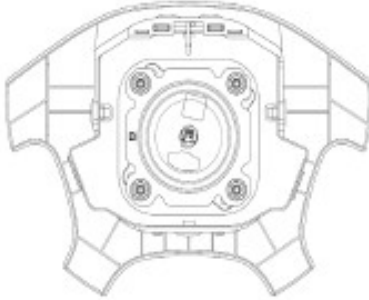

(4) Attach new nuts to the stud bolts.

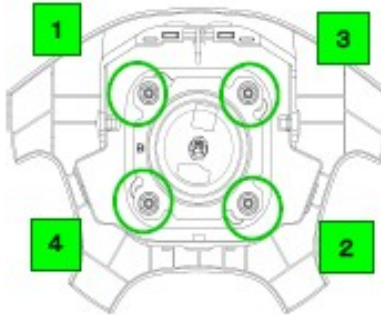

3. Tighten new nuts in accordance with the following steps.

(1) Tighten the nuts temporarily in sequential order as illustrated in step 1 to 4

(2) Tighten with the specified torque below.

Specified torque : 6.4 ± 0.8 [N·m]

CAUTION

Must use new nuts.



2. Squib harness modification (with on-vehicle condition)

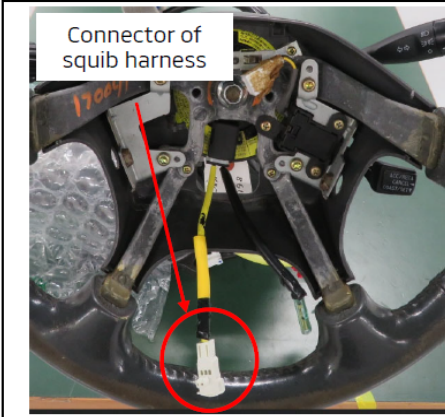

1. Modify and install the squib harness/connector.

CAUTION

- Do not pull and bend the harness strongly.
- Harness must be protected damage from edge of metal parts.
- Be careful of injury from edge of metal parts.
- Harness has no polarity.

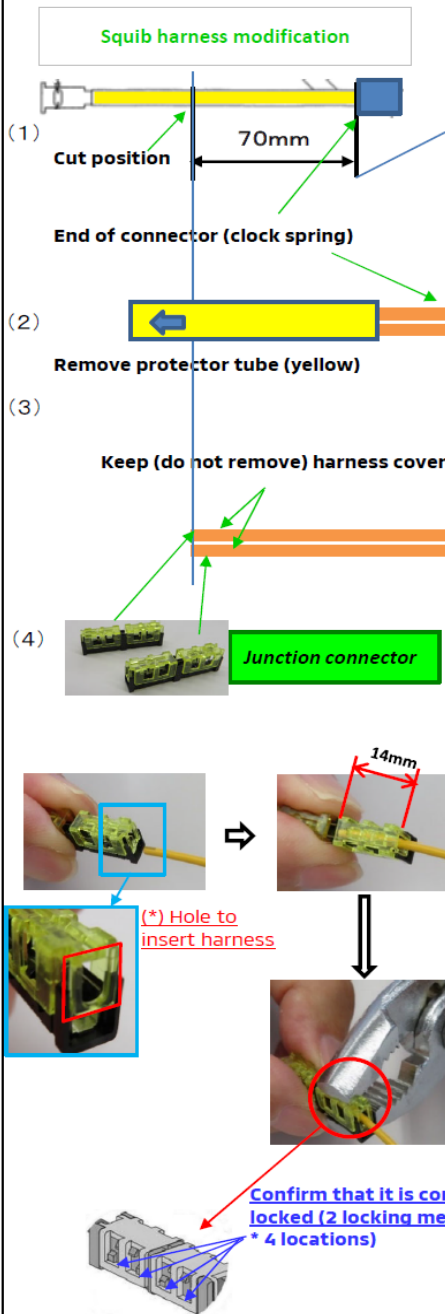

2. Modify the harness (with on-vehicle condition)

(1) Cut squib harness 70mm from the end of connector of clock spring side

(2) After cut, remove protector tube (yellow)

(3) Follow the steps below carefully.

CAUTION

- Do not peel off harness cover.
- Harness and connector must be protected from damage, dust and oil.
- Do not pull and bend the harness forcefully.

(4) Remove the junction connectors from the replacement kit and install them to the harness. (both 2 pcs)

CAUTION

- Without removing harness cover, insert harness from the hole of the junction connector until hitting to end of connector (end position is approx. 14mm) as indicated in the OK/NG photos.
- Open pliers wide and pinch the junction connector securely until the claws of the connector lock correctly (Total 8 locks - 2 locking mechanism * 4 locations).
- Do not reuse the junction connectors once it is locked.
- If performing recall repair under cold conditions (below **32 degrees Fahrenheit / 0 degrees Celsius**), warm up the harness using a hair dryer before harness connection to prevent hardening of the case resulting in no or poor continuity of the harness.

** Recommended temperature is from 32 to 104 degrees Fahrenheit / 0 to 40 degrees Celsius*

Confirm that it is correctly locked (2 locking mechanism * 4 locations)

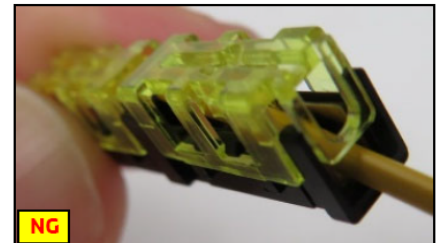

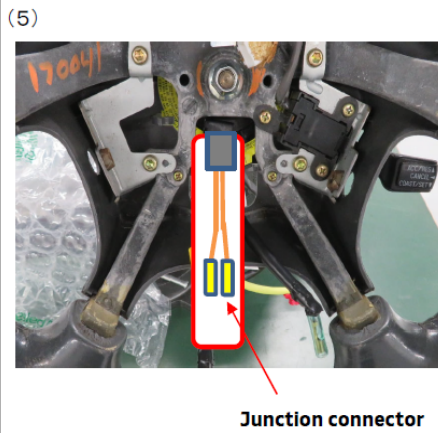

(5) Condition after attaching both connectors to the squib harnesses shown as left figure.

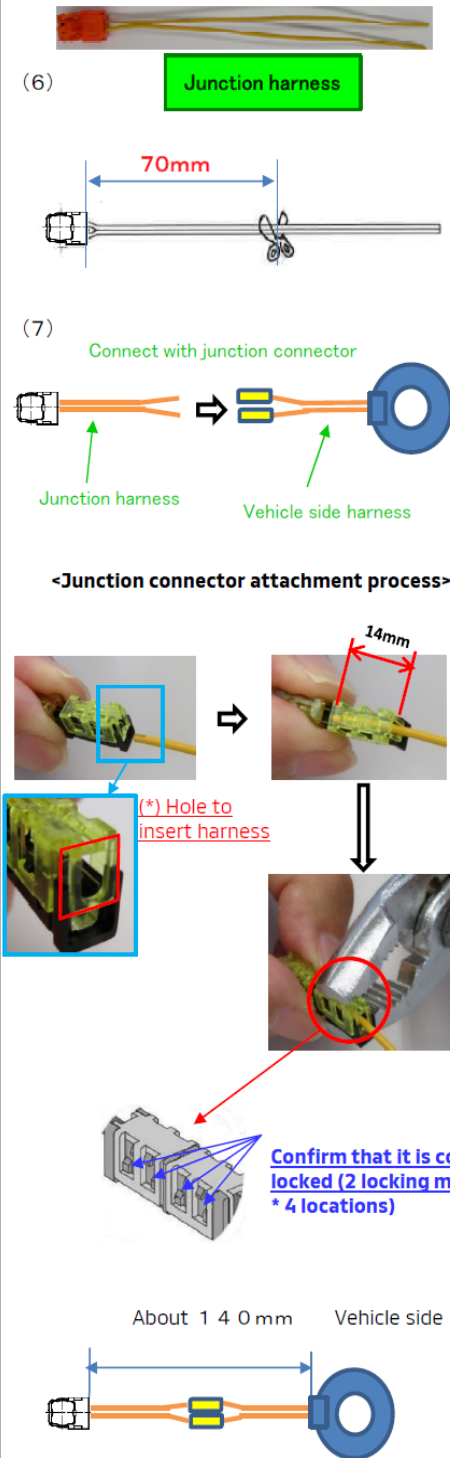

(6) Prepare junction harness

Take out the junction harness from the replacement kit.

Cut the junction harness 70mm from the end of connector.

(7) Connect junction harnesses (after cutting to 70mm) and vehicle (clock spring) side harnesses using junction connectors.

Steps for attaching junction connector is the same as (4)



CAUTION

- Harness has no polarity.
- Keep (do not remove) harness cover, and insert from the hole of the junction connector until hitting to end of connector. (this position is approx. 14mm)
- Open pliers wide and pinch the junction connector securely until the claws of the connector lock correctly (Total 8 locks - 2 locking mechanism * 4 locations).
- Do not reuse the junction connectors once it is locked.
- If performing recall repair under cold conditions (below **32 degrees Fahrenheit / 0 degrees Celsius**), warm up the harness using a hair dryer before harness connection to prevent hardening of the case resulting in no or poor continuity of the harness.

Recommended temperature is from 32 to 104 degrees Fahrenheit / 0 to 40 degrees Celsius

- Harness and connector must be protected from damage, dust and oil.

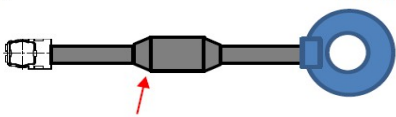
- Do not pull and bend the harness strongly.

<p>(8) Vehicle side</p>  <p>Wrap whole area of modified harness with Insulated tape.</p>	<p>(8) Wrap the entire area of modified harness with insulation tape.</p>
	<p>CAUTION</p> <ul style="list-style-type: none">- Wrap insulation tape so that half of tape is overlapped- Wrap insulation tape as much as possible until the end (within 5mm) <p>Condition after modifying the squib harness (red circle point as left figure)</p>

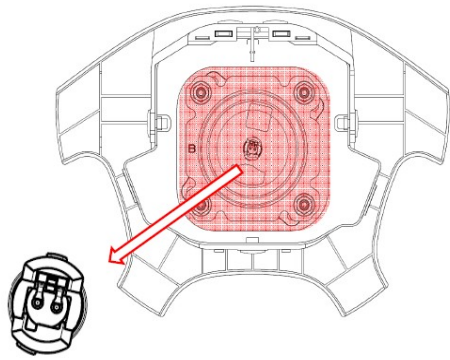
<p>3. Final check of modifying airbag module</p>	
 <p>Direction of connector</p>	<p>The completed airbag module is as the left figure.</p> <p>CAUTION</p> <ul style="list-style-type: none">- When installing it to steering wheel, check the direction of the inflator connector as the left figure.

All claims must include a photo of the new countermeasure Inflator kit after assembly—the photo must be posted to the Photos Required Condition (PRC) system in the “RECALL PHOTO/DOCS SUPPORT” category. The photo must clearly show the countermeasure Inflator kit assembled correctly.

NOTE: Photos must be posted on the PRC **BEFORE** entering the related Warranty claim.

Please continue posting the Driver Side Takata NADI Inflator photos to the PRC until a cancellation notice is published by MMNA headquarters.

SAMPLE PHOTO OF CORRECT INFLATOR KIT ASSEMBLY

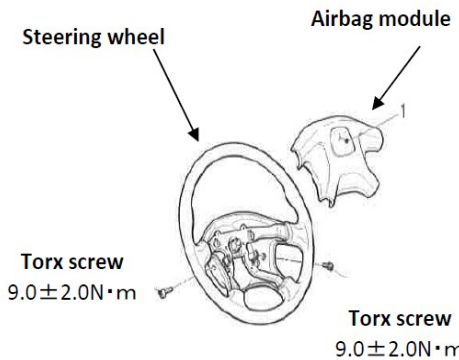
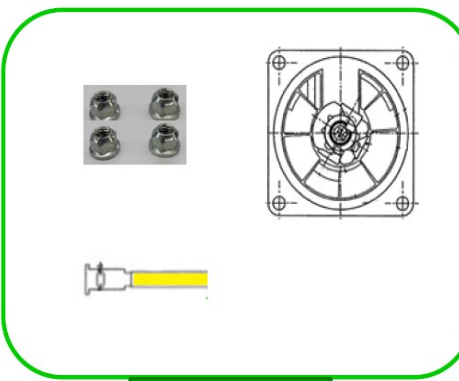

****DO NOT SHIP REPLACED INFLATORS TO MMNA****
SHIP TO TAKATA ONLY
SEE INSTRUCTIONS ON PAGE 13 OF THIS BULLETIN

<p>4. Install airbag module to vehicle</p>	
 <p>Steering wheel</p> <p>Airbag module</p> <p>Torx screw 9.0 ± 2.0 N·m</p> <p>Torx screw 9.0 ± 2.0 N·m</p>	<p>1. Install airbag module</p> <p>(1) Connect the vehicle side connector to driver's airbag module.</p> <p>(2) Connect horn harness</p> <p>(3) Tighten driver's airbag module with 2 torx screws (T30).</p> <p>Specified torque :9.0±2.0 [N·m]</p> <p>CAUTION</p> <ul style="list-style-type: none"> - Do not pull and bend the harness strongly. - Do not pinch the harness by installing the inflator. - Make sure the SRS warning light is not illuminated on the combination meter. after connecting the negative (-) battery terminal and IG-ON. - Return to original setting of Audio and Clock etc. - Start engine, and make sure the SRS warning light is not illuminated on the combination meter.
<p>5. Return parts</p>	
 <p>Return parts</p>	<p>1. Old inflator, 4 nuts, and cut squib harness (instructed in next page)</p> <p>All of these parts must be returned within the same box the new inflator kit were contained</p> <p>CAUTION</p> <ul style="list-style-type: none"> - Ensure the 4 nuts are the old parts removed. - Return the old inflator in the same replacement kit box - Do not mix up with other inflator packaging.

XPO RETURN POLICY ON TAKATA AIRBAGS/INFLATORS

- 1) Accumulate as many airbags/inflators for TK HOLDINGS as possible. (A minimum of 7 is required for LTL).
 - IF you have not accumulated 7 or more pieces within a two 2-week period, please contact us so we can send you PRP labels for FedEx Ground shipping
- 2) Begin to stack the pallet, ensuring NOTHING exceeds the edges of the pallet and preferably not over 5 ft high so the pallet will be structurally safe for transport. If your pallet does exceed 5 ft be sure to shrink wrapped securely and tie strap if possible, to avoid the carrier pick-up refusal fearing unsafe transport.
 - If the driver does refuse, you will need to redo pallet.
 - Note: If putting new and used on the same pallet you must group the new and place on the edge where they are clearly visible and preferably where you place your address and overpack labels.
- 3) Keep a count of how many Driver and Passenger side airbags/inflators you have on that pallet (WE MUST HAVE THIS TO SCHEDULE YOUR PICKUP). You can also send back multiple pallets if you have the capacity and ability to do so.
- 4) Once the pallet is ready and secure (WRAPPED OR TIED DOWN), you can either call or email your request to schedule the LTL pickup.
 - IF emailing your request PLEASE DO NOT EMAIL A REP DIRECTLY BUT USE THE EMAIL ADDRESS AT THE BOTTOM OF THESE INSTRUCTIONS.

After all the above is completed, we will contact and schedule the appropriate carrier for your pickup. We will request the pickup for the next business day but **may take up to 72 business hours depending on truck availability.**

- At this point, we will email you five documents:
 1. Bill of Lading
 2. Overpack
 3. ERG 171
 4. TK Holdings address label
 5. these return instructions





CONTACT INFORMATION

210-250-5079 or 210-250-5052

PARTS INFORMATION

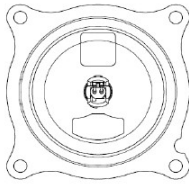
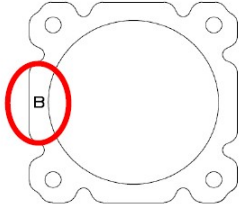
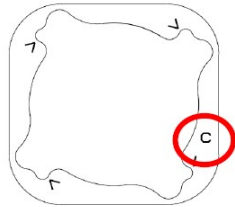
Part number	Model Code	Contents					
		Inflator	PLATE -B	PLATE -C	NUT M6	Junction harness	Junction connector
98510W040P	V10V,V10W,V20W,V50W, V20C,V30V,V30W,V40W, PA0V,PB0V,PD0V,PA0W, PB0W,PC0W,PD0W,PF0W	1	1	1	4	1	2

Required Tool:
Insulation tape

Components of inflator kit	
	1. Replacement new inflator : 1 pc
	2. Inflator mounting plate B : 1 pc *The identification mark is "B".
	3. Inflator mounting plate C : 1 pc *The identification mark is "C".
	4. Replacement nut (M6) : 4 pcs
	5. Junction harness: 1 pc
	6. Junction connector : 2 pcs

LABOR OPERATIONS

Involved Models	Campaign Op#	Labor Time	Repair Description
1998 - 2000 Montero	C2001R01	0.6 hrs.	Replace Driver Side Frontal Airbag Inflator

WARRANTY/RECALL CAMPAIGN CLAIM INFORMATION

Enter all claims as claim type 'C' - Recall/Campaign Claims.

Please follow the campaign instructions when entering each claim. See the claim example provided below.

RECALL CLAIM HEADER SECTION

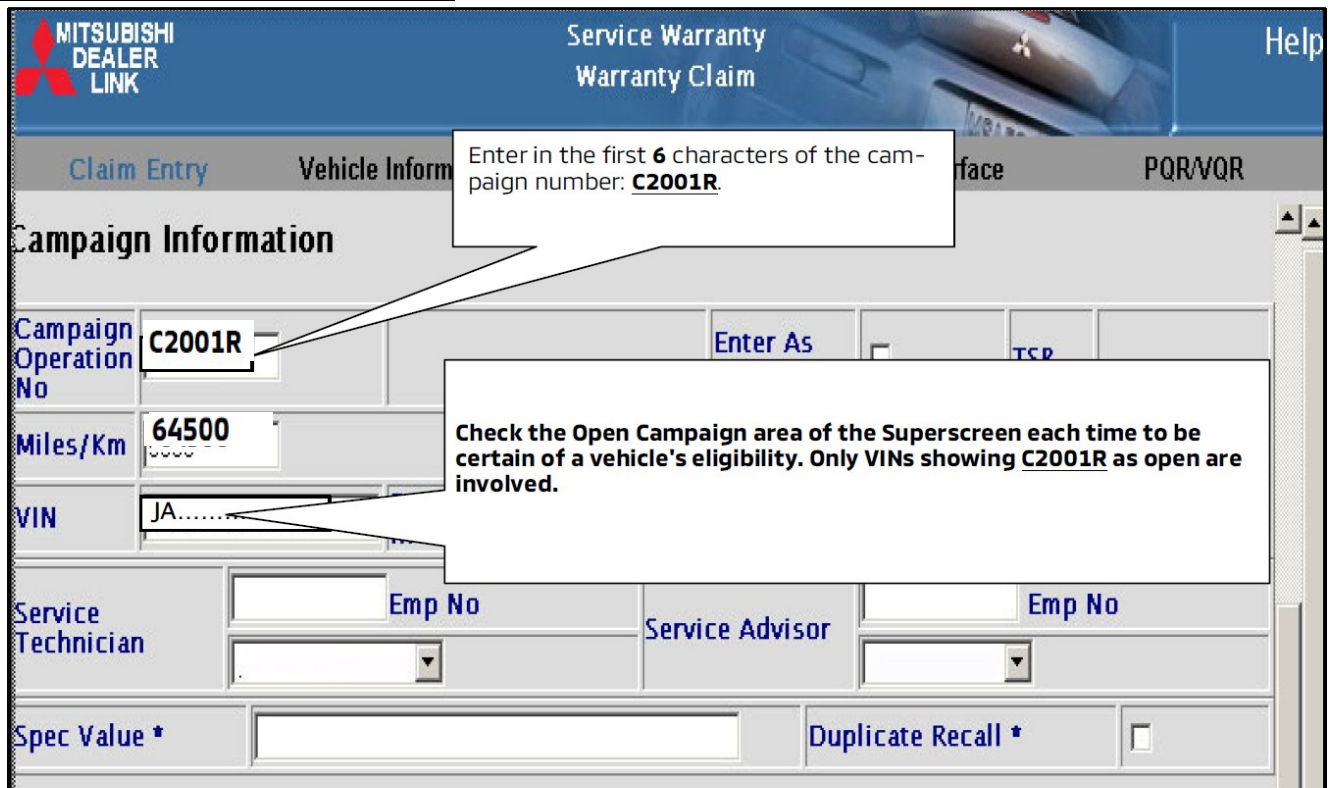

The screenshot shows the 'Service Warranty/Warranty Claim' form in the Mitsubishi Dealer Link system. The form is titled 'Claim Entry' and 'Vehicle Information'. It includes the following fields and callouts:

- Campaign Operation No:** C2001R. Callout: "Enter in the first 6 characters of the campaign number: **C2001R**."
- Miles/Km:** 64500. Callout: "Check the Open Campaign area of the Superscreen each time to be certain of a vehicle's eligibility. Only VINs showing **C2001R** as open are involved."
- VIN:** JA.....
- Service Technician:** [Empty field]
- Service Advisor:** [Empty field]
- Emp No:** [Empty field]
- Spec Value *:** [Empty field]
- Duplicate Recall *:** [Empty checkbox]

After entering the required customer data, vehicle information, selecting the applicable repair campaign, scenario performed (please note there are 2 possible repair scenarios for this campaign), and then clicking the "Save and Continue" button; the system will automatically fill-in several fields.



IMPORTANT SAFETY RECALL

Mitsubishi Motors North America, Inc.
PO Box 689040
Franklin, TN 37068
Telephone: 888-648-7820
www.mitsubishicars.com

This notice applies to your vehicle, _____.

Date: February 2021

Dear FIRSTNAME LASTNAME,

This notice is sent to you in accordance with the National Traffic and Motor Vehicle Safety Act.

Reason for notice: Mitsubishi Motors North America, Inc. (MMNA) has decided that a defect which relates to motor vehicle safety exists in certain **1998 - 2000 Montero vehicles**. According to Takata, Non-Azide Driver Air Bag Inflators (NADI) manufactured between May 1995 and March 1999 (installed in certain 1998 – 2000 Montero vehicles) may absorb moisture, causing the NADI Inflators to rupture or the airbag cushion to underinflate in vehicle collisions involving airbag deployment. If a NADI Inflator ruptures or the airbag cushion underinflates in a vehicle crash involving airbag deployment, vehicle occupants would be at an increased risk of serious injury or death.

What you should do: Please contact your local Mitsubishi Motors dealer and schedule an appointment to have the affected NADI Inflators replaced, free of charge. When you bring your vehicle in, please show the dealer this letter. If you misplace this letter, the dealer will still perform this repair for your vehicle, free of charge.

What your dealer will do: The dealership will replace the NADI Inflator with a countermeasure unit.

How long will it take? The time needed for this repair is approximately **36 minutes**. The dealer may need your vehicle for a longer period of time, but every effort will be made to minimize your inconvenience.

If you experience any problem having your vehicle repaired promptly and/or at no charge, please inform us by calling the Mitsubishi Customer Relations Department at **888-648-7820**. Hours: Monday through Friday 7 a.m. to 4 p.m. (Central Time)

If, after contacting Mitsubishi Customer Relations, you still have a problem getting this repair made promptly and/or without charge, you may submit a complaint to the Administrator, National Highway Traffic Safety Administration, 1200 New Jersey Avenue SE, Washington, D.C. 20590, or call the toll-free Vehicle Safety Hotline at 1-888-327-4236 (TTY: 1-800-424-9153) or go to <http://www.safercar.gov>.

If you have already encountered a problem with the NADI Inflator and had it replaced as a result of this specific condition and have paid for the repair, you may send your original repair order or invoice, **and** original receipt/proof of payment to the following address for reimbursement consideration:

Mitsubishi Motors North America Inc., Customer Relations, P.O. Box 689040, Franklin, TN 37068

If you are the lessor of this vehicle, please forward a copy of this notice to the lessee within ten days to comply with federal regulations.

We appreciate your prompt attention to this matter.

Sincerely,

Mitsubishi Motors North America, Inc.

C2001R