

TECHNICAL INSTRUCTIONS

FOR

SAFETY RECALL 20TA03

**INCOMPLETE OR NONDEPLOYMENT OF AIRBAGS AND/OR SEAT BELT
PRETENSIONERS MAY OCCUR**

CERTAIN

2014 – 2019 COROLLA

The repair quality of covered vehicles is extremely important to Toyota. All dealership technicians performing this recall are required to successfully complete the most current version of the E-Learning course “Safety Recall and Service Campaign Essentials”. To ensure that all vehicles have the repair performed correctly; technicians performing this recall repair are required to currently hold at least one of the following certification levels:

- Expert (Electrical or Hybrid)
- Master
- Master Diagnostic Technician

It is the dealership’s responsibility to select technicians with the above certification level or greater to perform this recall repair. Carefully review your resources, the technician skill level, and ability before assigning technicians to this repair. It is important to consider technician days off and vacation schedules to ensure there are properly trained technicians available to perform this repair at all times.

I. OPERATION FLOW CHART

The flow chart is for reference only. **DO NOT** use it in place of the full technical instructions. Follow **ALL** steps as outlined in the full technical instructions to confirm the campaign is completed correctly.

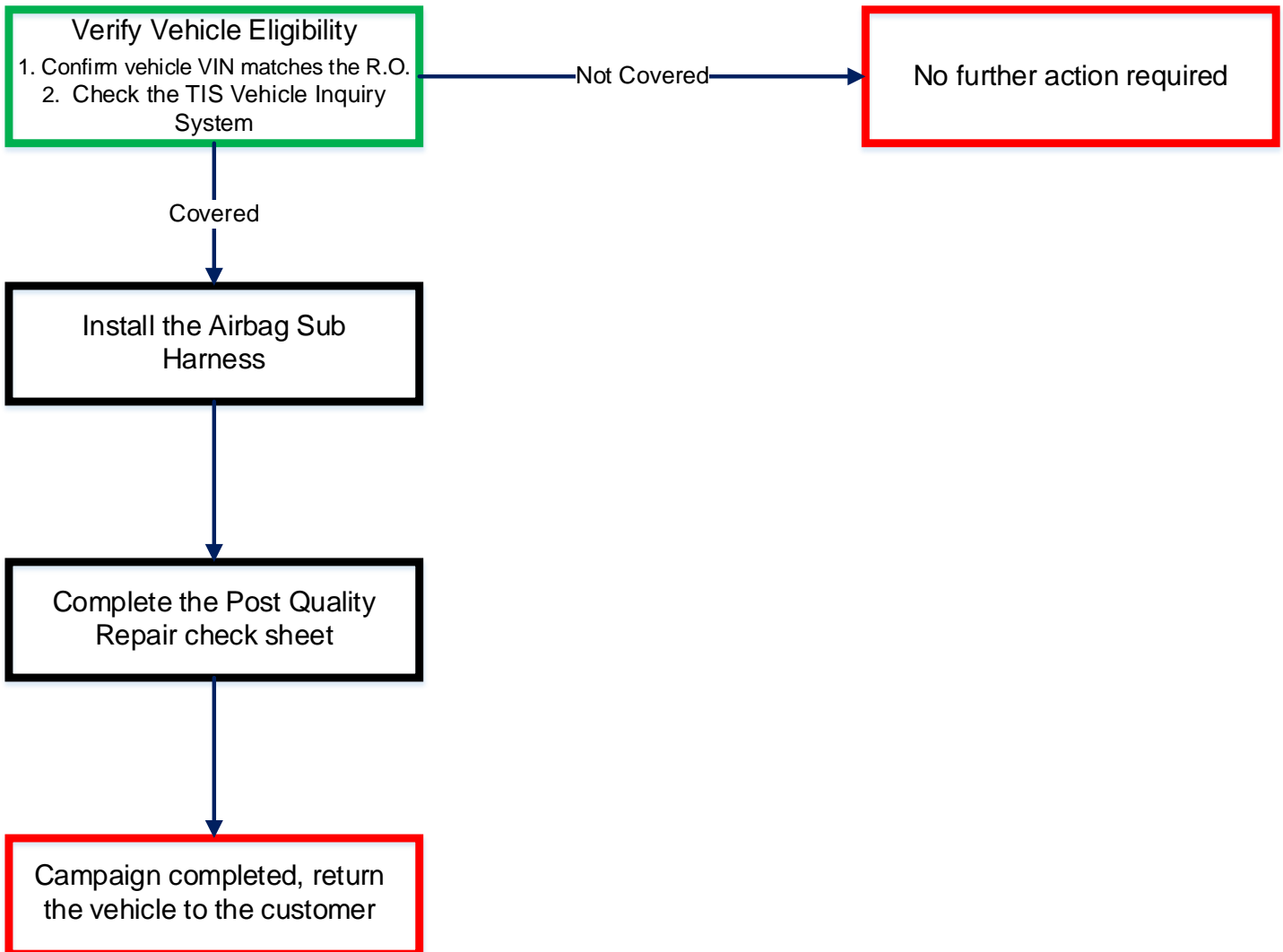

II. IDENTIFICATION OF AFFECTED VEHICLES

A. COVERED VIN RANGE

NOTE:

- Check the TIS Vehicle Inquiry System to confirm the VIN is involved in this Safety Recall, and that the recall has not already been completed prior to dealer shipment or by another dealer.
- TMNA warranty will not reimburse dealers for repairs conducted on vehicles that are not affected or were completed by another dealer.

III. PREPARATION

A. PARTS

Part Number	Part Description	Quantity
04009-98112	Airbag Harness Kit*	1
* The kit above includes the following parts:		
Part Number	Part Description	Quantity
82821-12C30	Urethane Sheet	1
89171-12020	Airbag Sub Harness	1
89279-12180	Water Guard Sheet 5.91in. (150mm) x 5.91in.(150mm)	1
89279-12190	Water Guard Sheet 4.72in. (120mm) x 5.91in. (150mm)	1
89279-12200	Water Guard Sheet 3.15in. (80mm) x 3.94in.(100mm)	1
89639-12020**	Cable Tie	7
90980-12878	Connector Holder	1

**: You may not use all the cable ties depending on the vehicle/configuration

B. TOOLS & EQUIPMENT

- Standard Hand Tools
- Techstream
- Work Gloves
- Molding Remover

C. MATERIALS

- Protective Tape
- Marker pen
- Vinyl Tape

IV. WORK PROCEDURE TABLE OF CONTENTS

SAFETY PRECAUTIONS.....	SECTION V.
INSTALL AIRBAG SUB HARNESS	SECTION VI.
APPENDIX.....	SECTION VII.

V. SAFETY PRECAUTIONS



CRITICAL INFORMATION – READ THOROUGHLY



Always remember “SAFETY FIRST”.

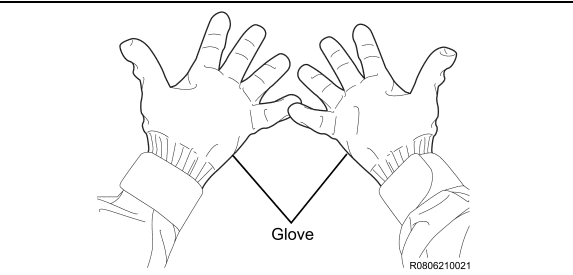

1. TAKE PREVENTIVE MEASURES AGAINST INJURY
 - a) Wear gloves so as not to get injured by burrs etc. on the instrument panel reinforcement and the bracket.

VI. INSTALL AIRBAG SUB HARNESS COMPONENTS

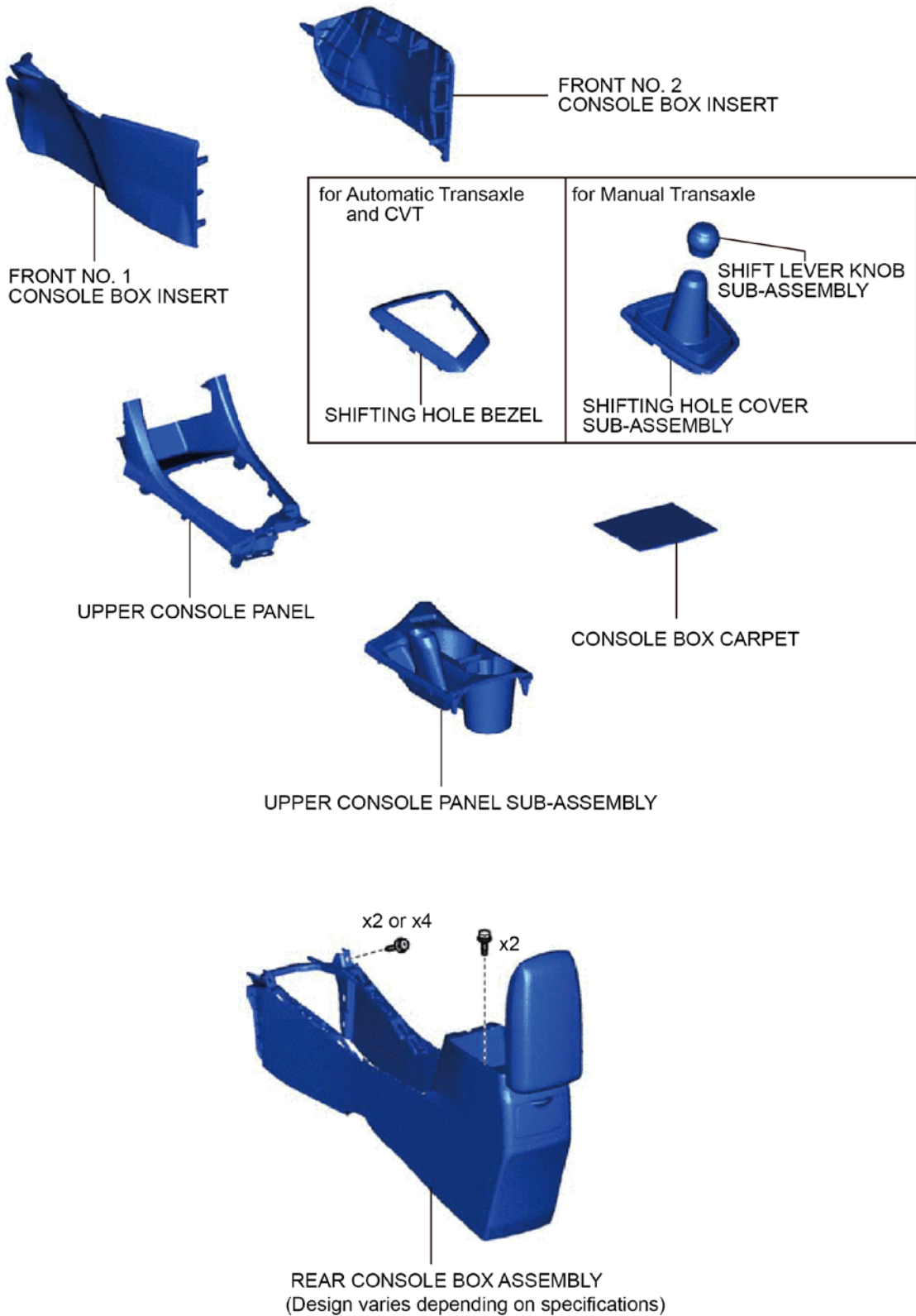

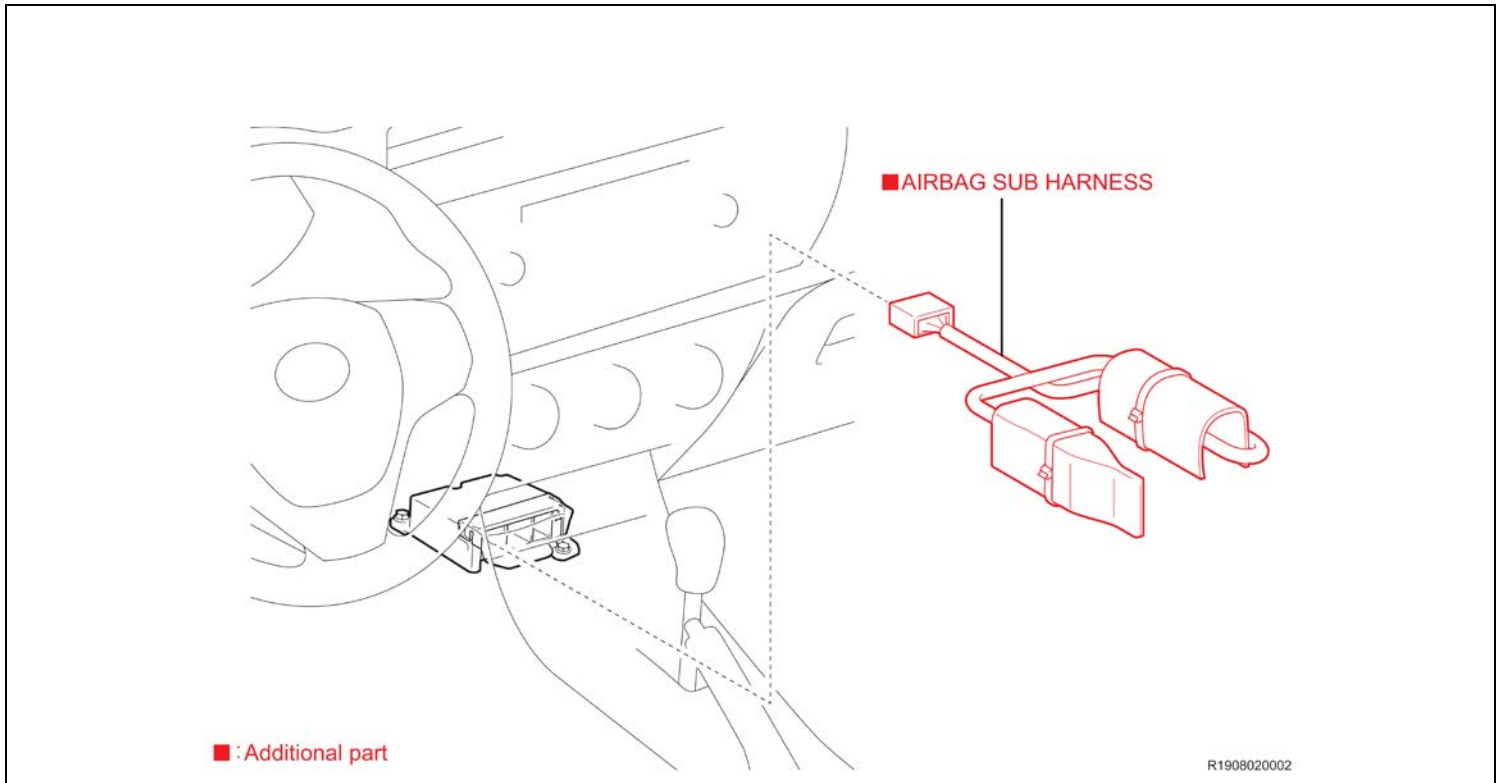

1. DISCONNECT THE NEGATIVE BATTERY CABLE



- Wait at least 90 seconds after disconnecting the cable from the negative battery terminal to prevent airbag and seat belt pretensioner deployment.
- Follow all precautions as outlined on TIS before servicing the SRS system.

2. DISCONNECT THE CONNECTOR OF THE AIRBAG SENSOR ASSEMBLY

a. Click the link below to access TIS for instructions

[SUPPLEMENTAL RESTRAINT SYSTEMS: CENTER AIRBAG SENSOR ASSEMBLY: REMOVAL; 2014 - 2019 MY Corolla](#) (RM100000009JTR)

NOTE:

- The following step **DOES NOT** need to be done although it is described in the repair manual.
 - Center instrument cluster finish panel sub-assembly. (Only 17MY-19MY)
- It is not necessary to remove the airbag sensor assembly. (All Model Years)

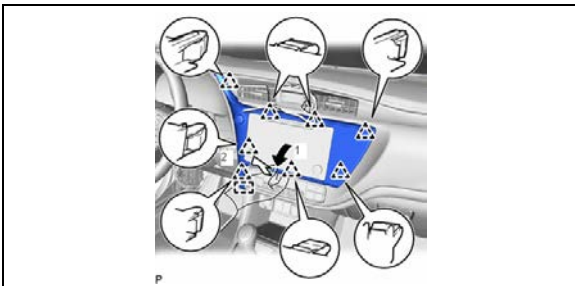

It is not necessary to remove the center instrument cluster finish panel sub-assembly.

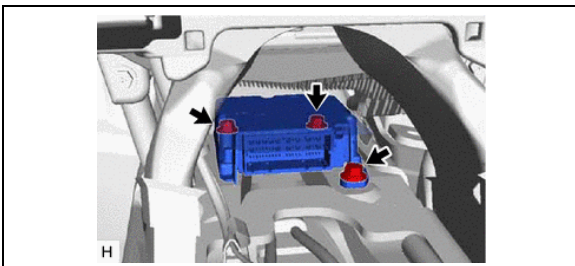

It is not necessary to remove the airbag sensor assembly

3. PREPARE AIRBAG SUB HARNESS

Click the play button to watch a video on how to prepare the airbag sub harness

NOTE: The video may take several minutes to load depending on internet connection.



IMPORTANT



The procedure shown in these technical instructions is for 2014 - 2019 COROLLA only. **DO NOT** use it for other vehicle models.

Install each water guard sheet properly

There are 3 different water guard sheets which will be used to protect the airbag sub harness.

Each water guard sheet has double-sided tape on a side. If you install a sheet at a wrong position and seal with the tape, the sheet will no longer be reusable. Please make sure to follow the instructions on these Technical Instructions and install each sheet at correct positions.

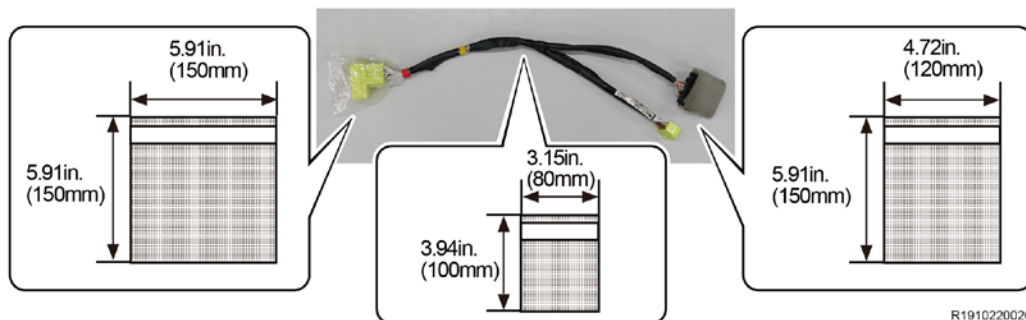

Handling of airbag sub harness

- **DO NOT** twist the airbag sub harness forcibly as it may be damaged.
- **DO NOT** touch the terminals of the link connector. Also, make sure that no foreign matter enters the terminals of the link connector.

NG

DO NOT forcibly twist the harness



NG

DO NOT touch the terminals. Also, **DO NOT** allow foreign matter enter.

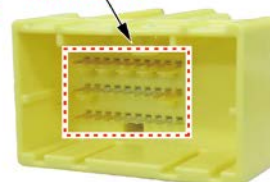

R1910230025a

- a) Before starting the procedure, place the airbag sub harness following the instructions below to ensure you are dealing with it at the proper orientation.
- (1) Place the module and connector (30P) to the right side seen from you.
 - (2) Place the link connector to the left side seen from you.

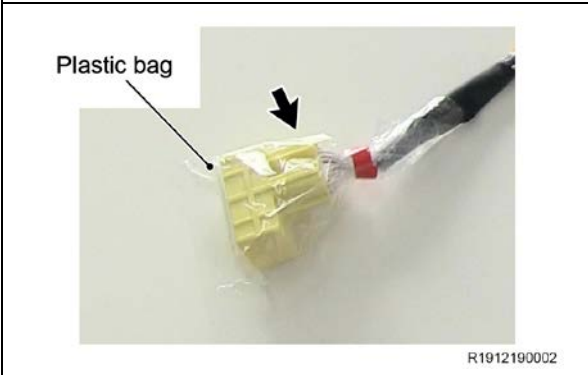
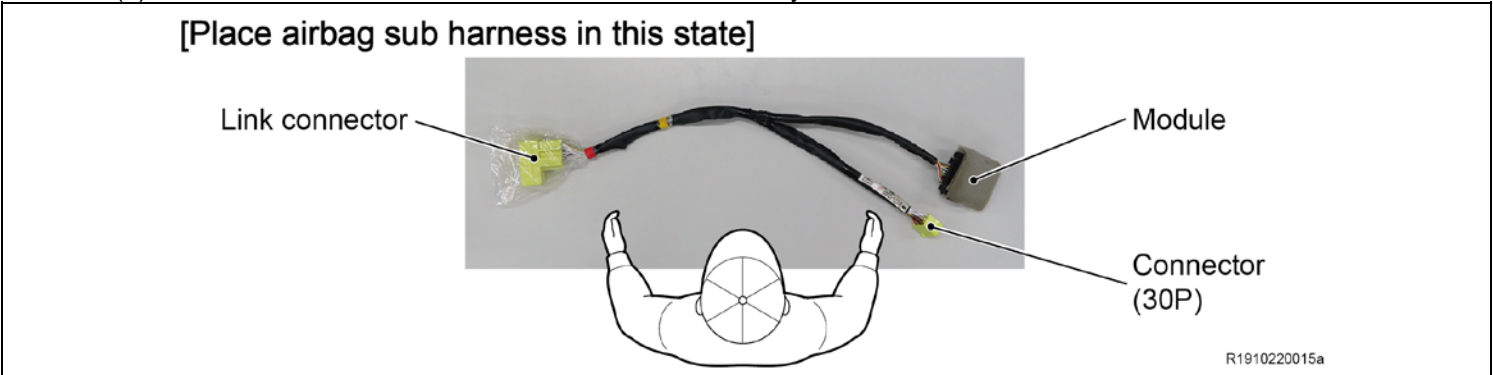

- b) Remove the plastic bag.

STOP *ENSURE the urethane sheet is flush with the connector in the next step.*

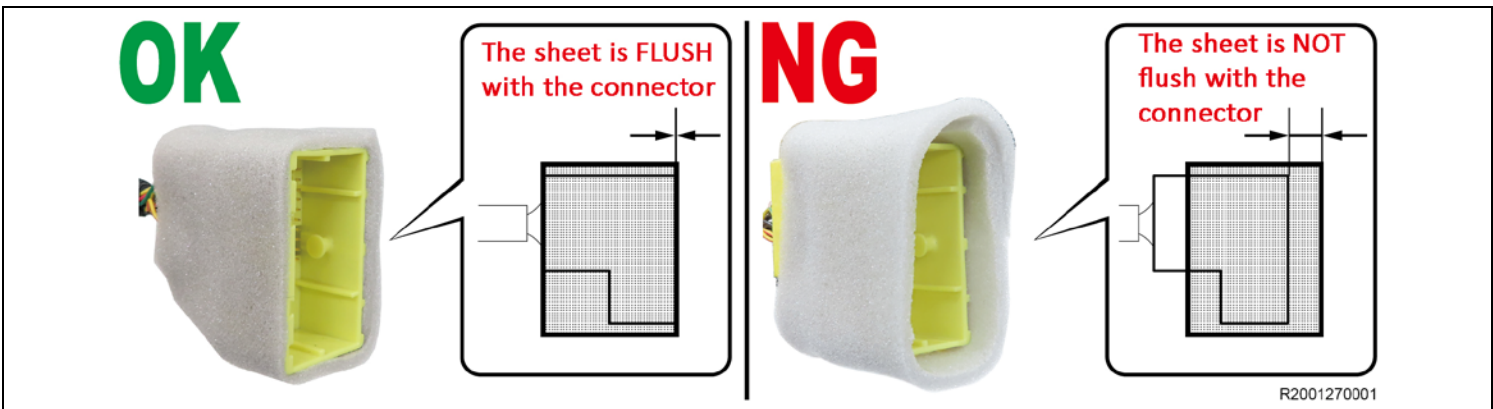

- c) Wrap the urethane sheet (7.87in. (200mm) x 1.97in. (50mm)) around the link connector.

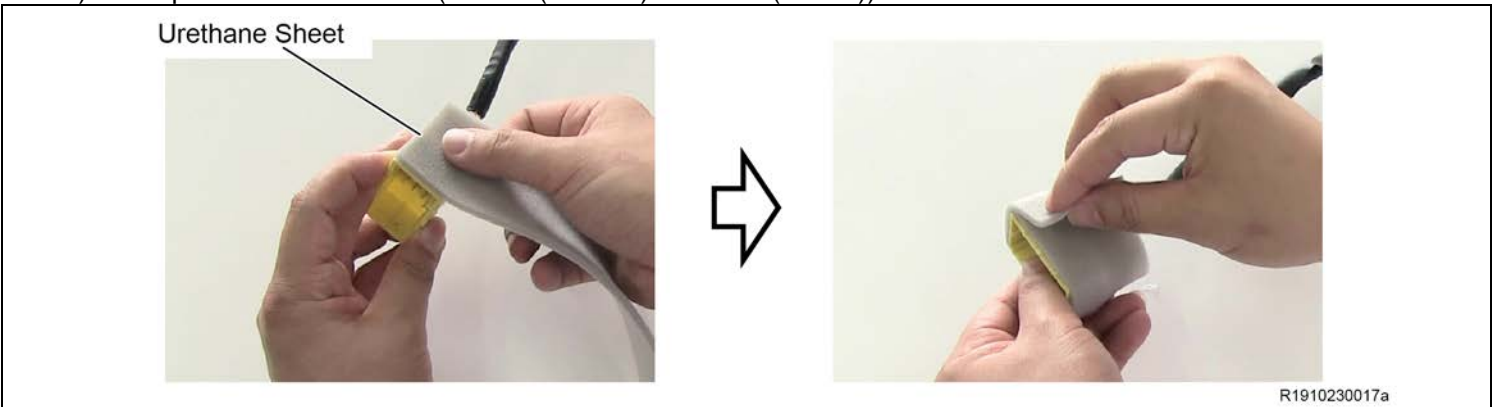

d) Press the position shown in the illustration (concave part) with your finger to remove any gap.

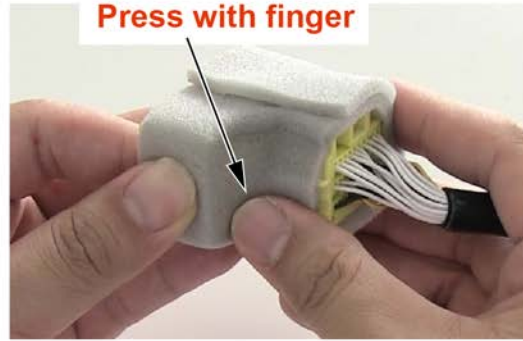

R1910230019a

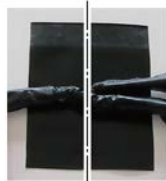

Place separating point of sub harness to the center



R1910230020



Wrap the water guard sheet from the no double-sided tape side



R1910230021

Fix both ends with vinyl tape

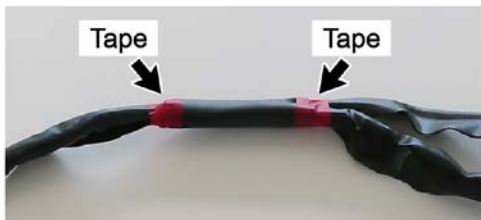

R1910230022

e) Remove the release paper of the double-sided tape.

f) Place the smallest water guard sheet (3.15in. (80mm) x 3.94in. (100mm)) so that its double-sided tape side comes to the farther side from you, and then place the separating point of the airbag sub harness at the center of the sheet.

NOTE:

DO NOT place the water guard sheet in a wrong direction. Make sure that the double-sided tape side is on the farther side from you.

g) Wrap the water guard sheet from the side without double-sided tape, and then seal with double-sided tape for temporary fixing.

h) Double-check the airbag sub harness is placed correctly on the sheet.

i) Fix the both ends of the water guard sheet with vinyl tape.

NOTE:

Make sure that the water guard sheet is securely fixed.

j) Bend the harness and align the marking with the end face of the link connector.

NOTE: DO NOT twist harness forcibly.

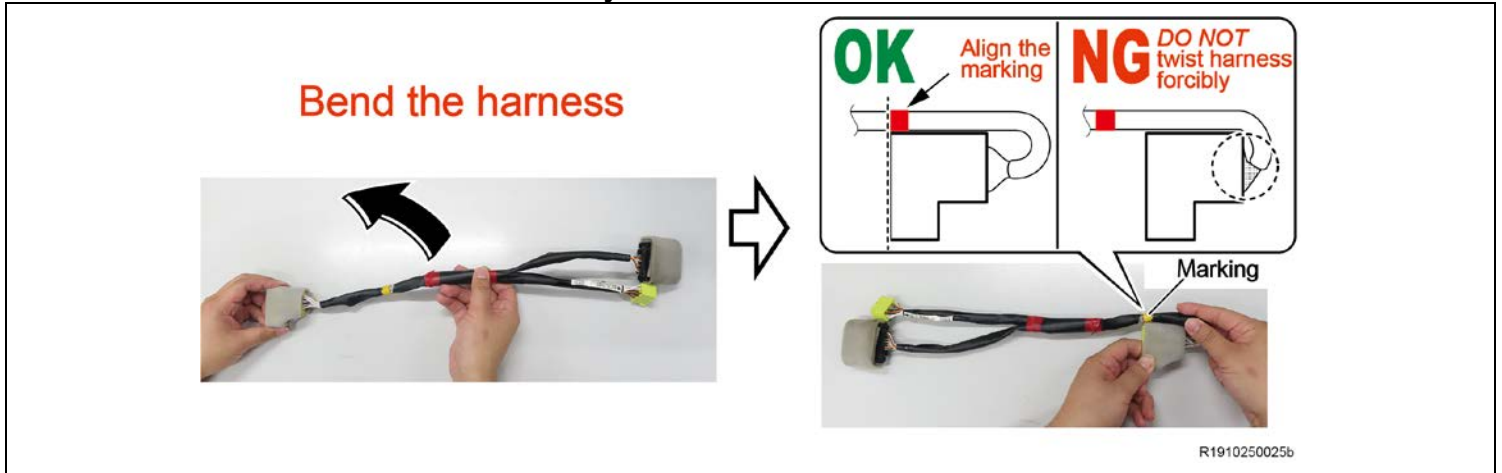

k) Remove the release paper of the double-sided tape.



l) Place the biggest water guard sheet (5.91in. (150mm) x 5.91in. (150mm)) so that its double-sided tape side comes to the right side, and then place the **link connector (Yellow color)** as shown in the illustration.

NOTE:

Place the link connector so that its connecting part to instrument panel wire comes to the side with no double-sided tape of the water guard sheet.



m) Fold the water guard sheet so that its end is aligned with the end of the link connector.

n) Make sure that the both ends of the folded water guard sheet and the link connector are aligned, and then seal the water guard sheet with double-sided tape.

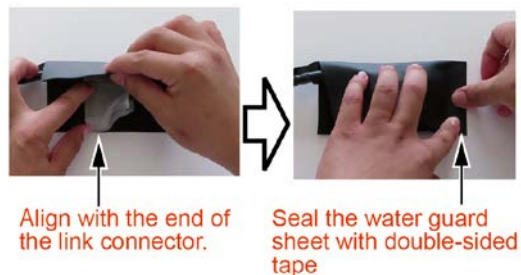

o) Double-check the marking is on the end face of the link connector.

p) Set a cable tie at center of the convex part of the link connector and fix the water guard sheet and link connector securely.

NOTE:

- A gap between the cable tie and the water guard sheet may cause the tie eventually be loosened and released. Make sure that the gap is reduced as much as possible.

- Make as little wrinkles as possible on the water guard sheet when installing it.

q) Cut off the excess of the cable tie.

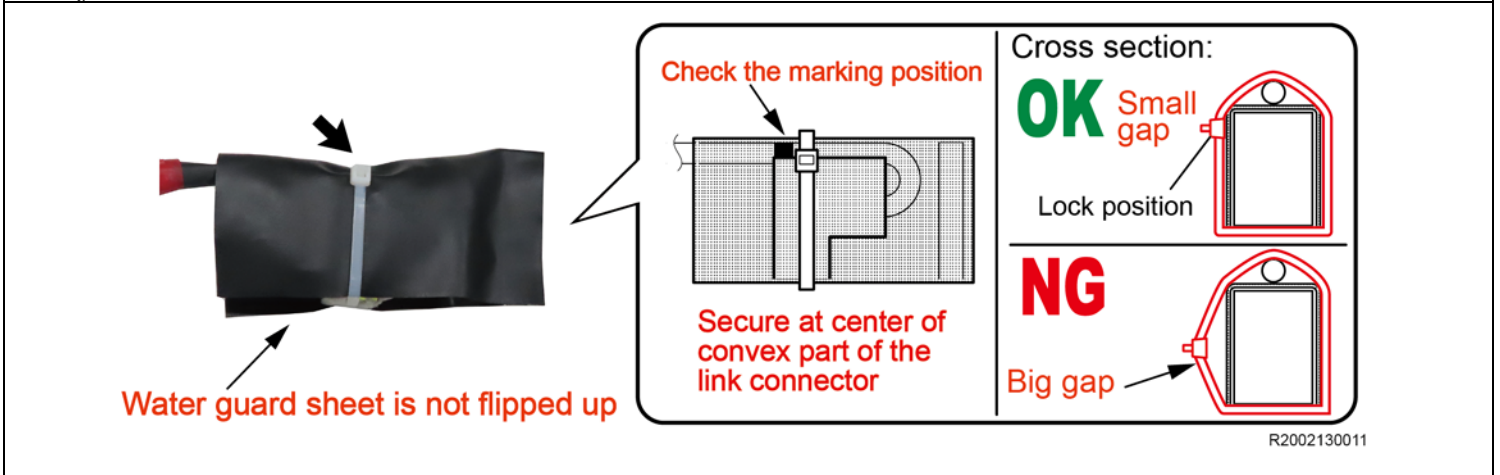

r) Remove the release paper of the double-sided tape.

s) Place the water guard sheet (4.72in. (120mm) x 5.91in. (150mm)) so that its double-sided tape side comes to the farther side from you, and then place the **module (Black color)** as shown in the illustration.

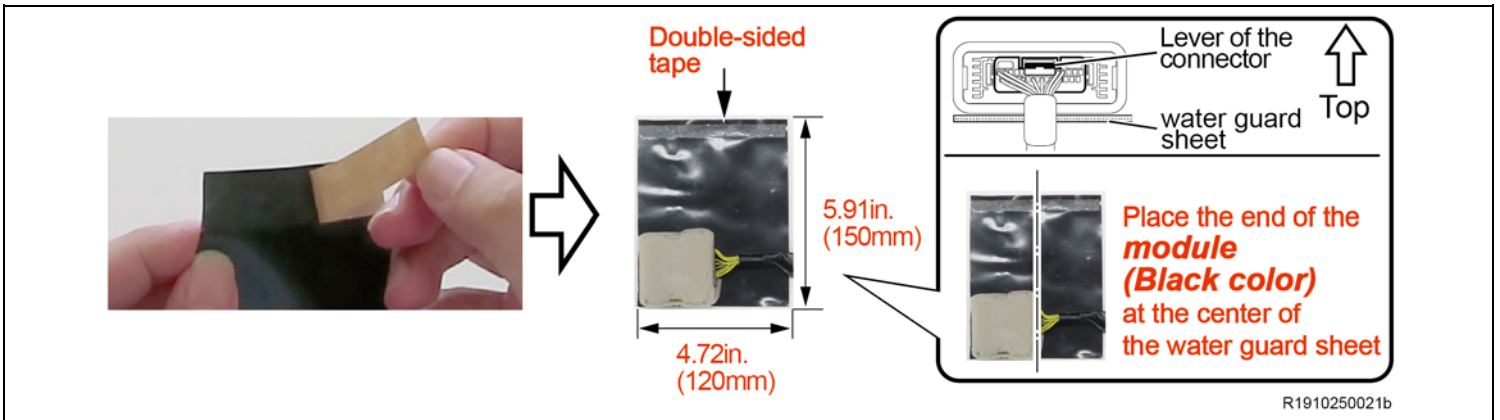

t) Wrap the water guard sheet around so that it does not wrinkle.

u) Make sure that the water guard sheet is not wrinkled and seal the water guard sheet with double-sided tape.

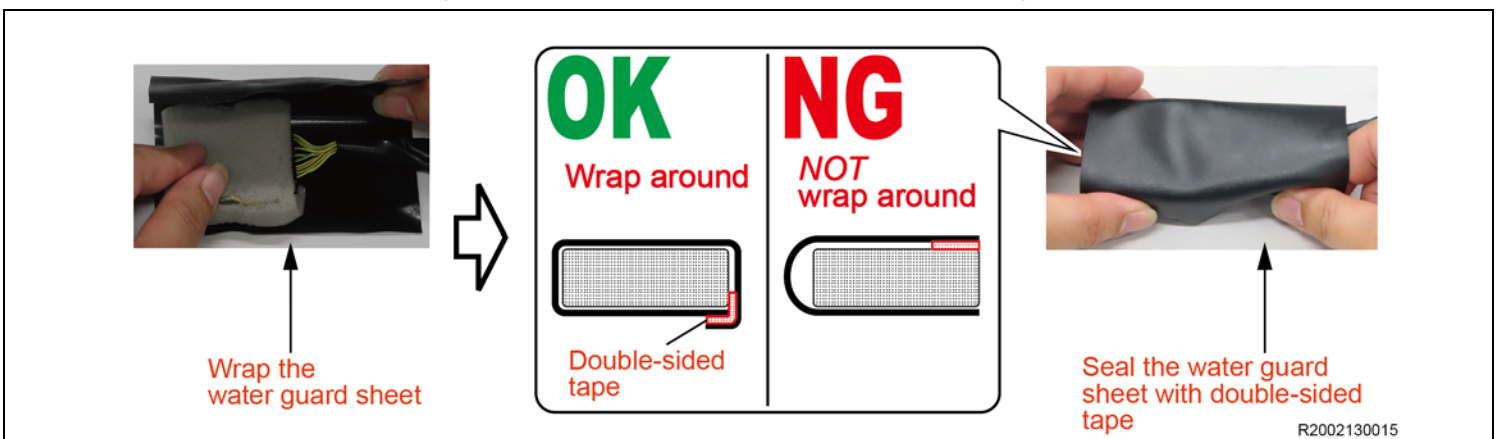

v) Set a cable tie at center of the module and fix the water guard sheet and module securely.

NOTE:

- A gap between the cable tie and the water guard sheet may cause the tie eventually be loosened and released. Make sure that the gap is reduced as much as possible.
- Make as little wrinkles as possible on the water guard sheet when installing it.

w) Cut off the excess of the cable tie.

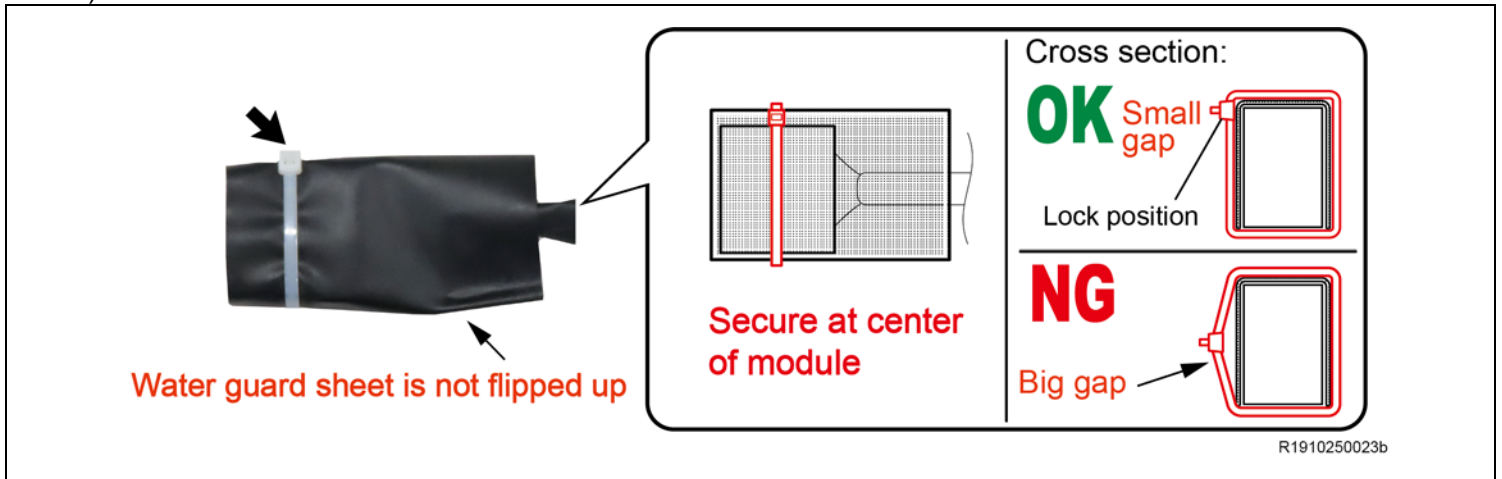

STOP

INTERMEDIATE INSPECTION (BY ANOTHER TECHNICIAN)

STOP

Confirm airbag sub harness is in proper condition

- Check the cable tie is fixed properly and if it is installed loose (big gap), tighten up the cable tie until fixed tightly (small gap).
- Confirm that the cable tie is installed at the center of the convex part of the link connector.
- Confirm that the cable tie is installed at the center of the module.
- Confirm that the water guard sheet is not flipped up.

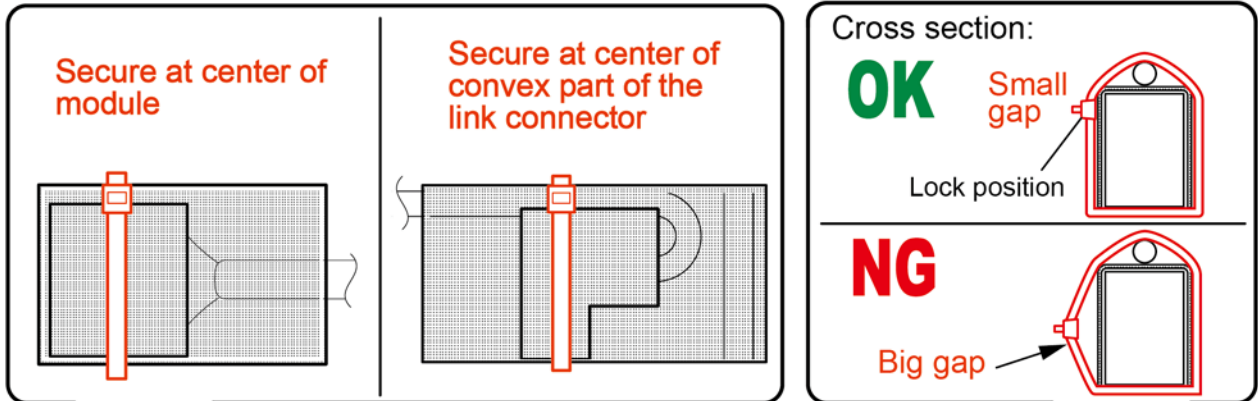

R2002130016

4. INSTALL AIRBAG SUB HARNESS

Click the play button to watch a video on how to install the airbag sub harness

NOTE: The video may take several minutes to load depending on internet connection.



The procedure shown in these technical instructions is for 2014-2019MY COROLLA only. **DO NOT** use it for other vehicle models.

- a) Using a screwdriver, disengage the 2 claws to release the retainer from the connector holder of the airbag sensor.

NOTE:

DO NOT remove the retainer from the connector holder completely. If removed, temporarily install it to the connector holder.

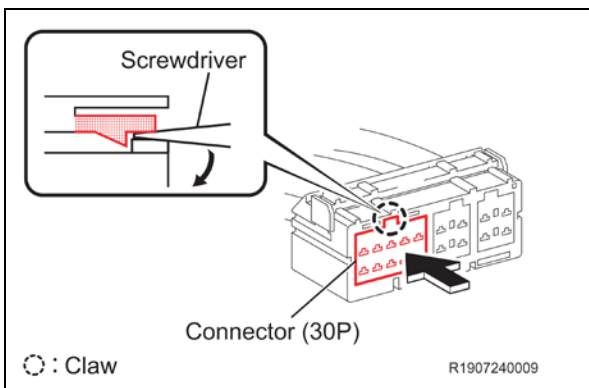
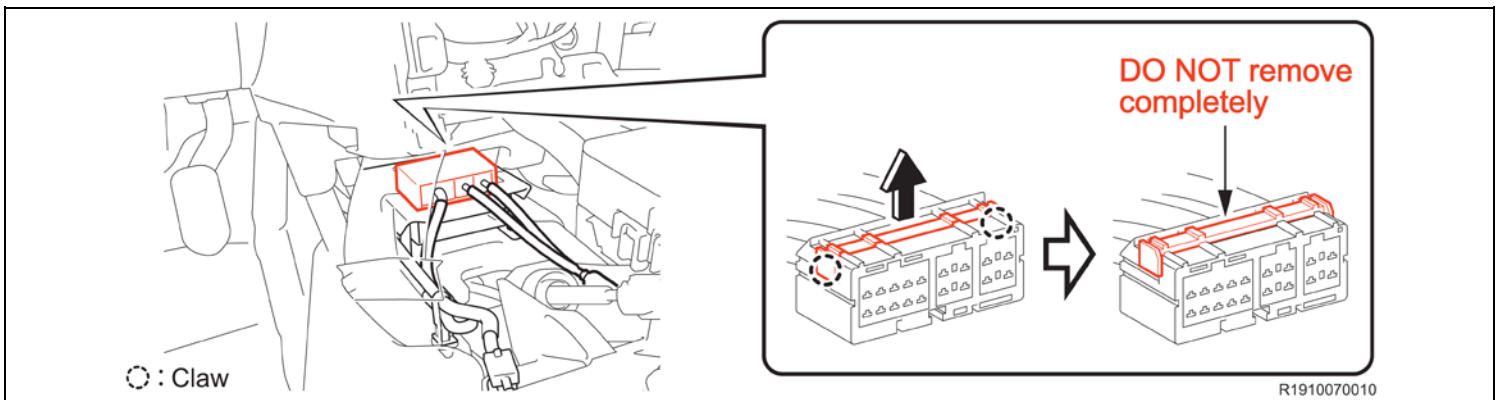

- b) Using a screwdriver, disengage the claw and remove the connector (30P) from the connector holder.

- c) Install the connector (30P) of the instrument panel wire to the provided connector holder and lock the retainer securely.



- Make sure that the connector (30P) is securely installed to the connector holder (provided).
- Securely lock the retainer.
- **DO NOT** lock the lever yet.

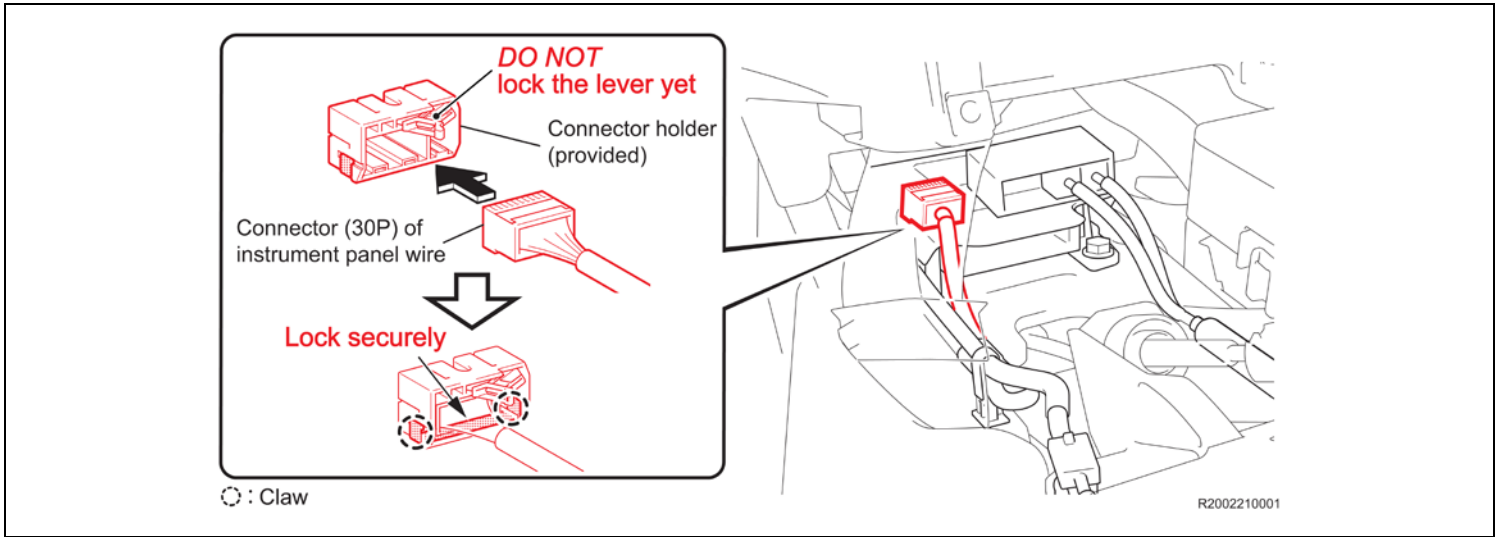

- d) Flip up the water guard sheet of the link connector and connect the connector (30P) with connector holder (provided).
 e) Lock the lever securely.



- **DO NOT** twist the airbag sub harness forcibly as it may be damaged.
- **DO NOT** touch the terminals of the link connector. Also, make sure that no foreign matter enters the terminals of the link connector.
- Securely lock the lever.
- Make sure that the water guard sheet is not flipped up and not pinched.

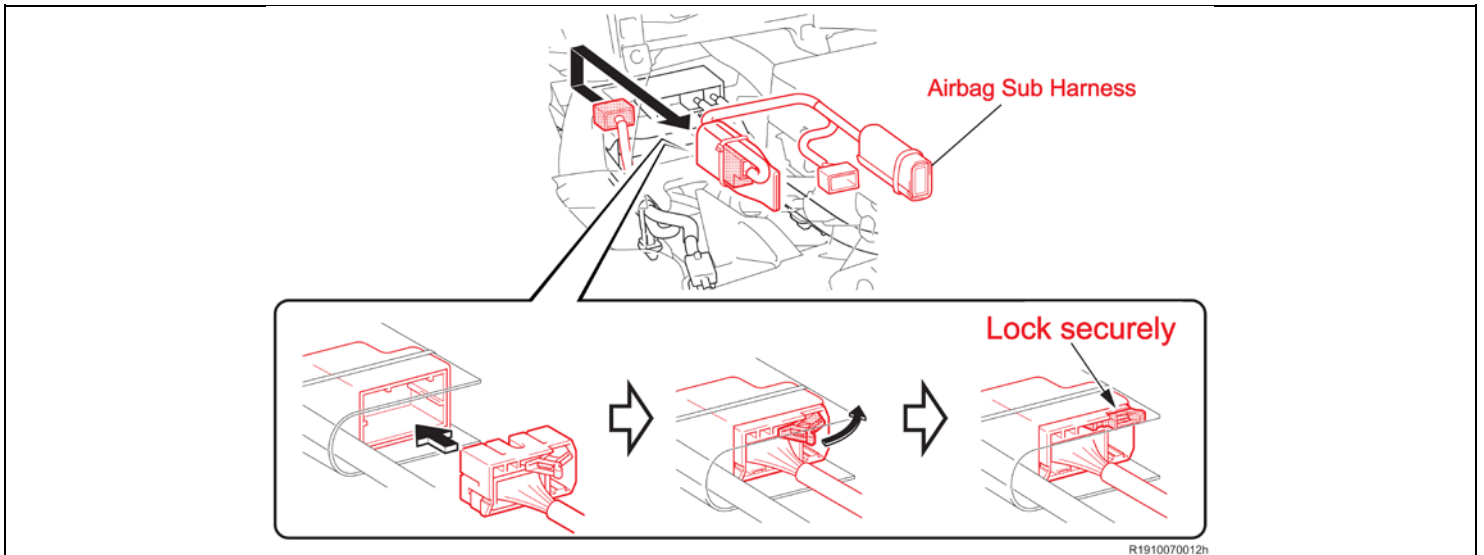

[Place airbag sub harness in this state]

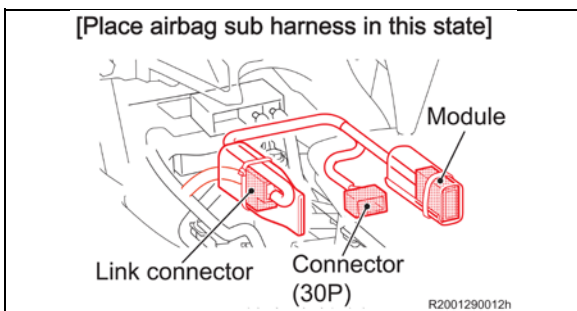

- f) Lay out each part of the airbag sub harness as shown in the illustration.

NOTE:

Check the direction of the water guard sheet. The side which is not covered by the water guard sheet of the link connector and module must face downwards.

STOP

IMPORTANT

STOP

g) Pass the connector (30P) of airbag sub harness under the harness as shown in the illustration.

NOTE:

Make sure to pass the connector (30P) under the harness. Otherwise water may run along the harness of the connector (30P) and enter the ECU, resulting in damage of the ECU in the worst case. This may prevent the airbag from being deployed.



h) Connect the connector (30P) of airbag sub harness to the connector holder of the airbag sensor and lock the retainer securely.

STOP

Securely lock the retainer.

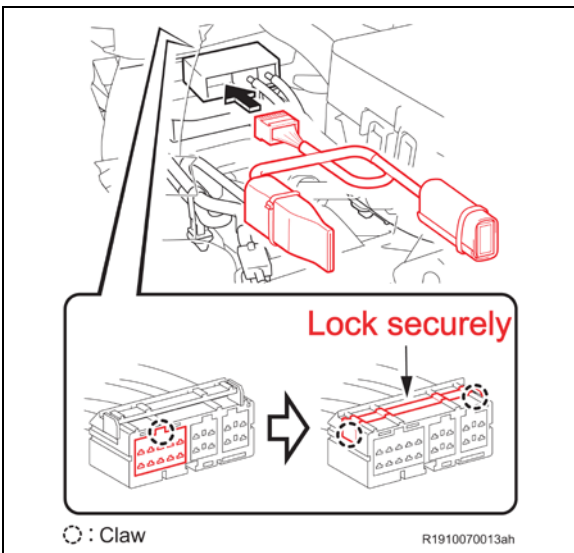

- i) Connect the connector holder to the airbag sensor.
- j) Lock the lever securely.

STOP

- Securely lock the lever.
- Make sure that the water guard sheet of the airbag sensor is not flipped up or caught.

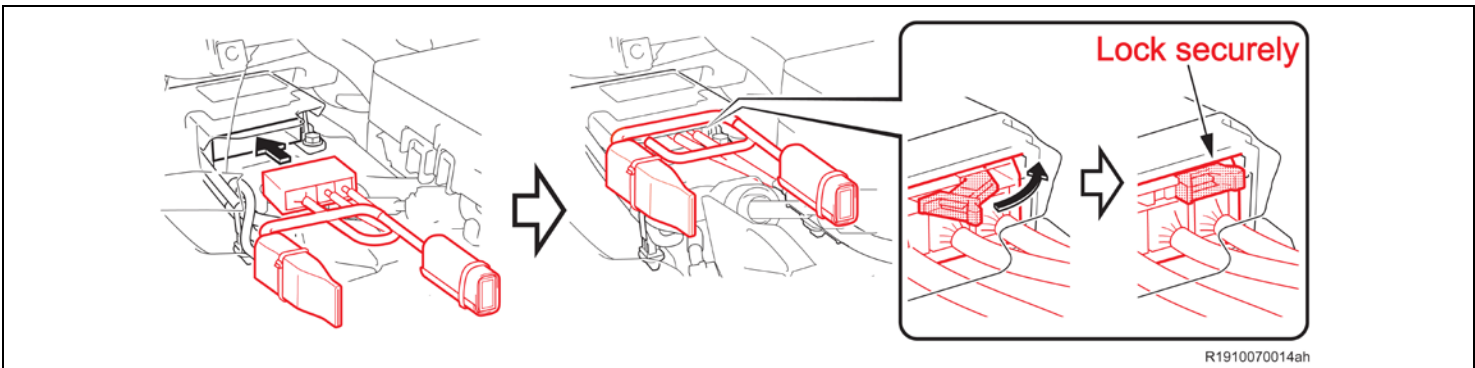

STOP

Check each connector is securely connected.
(The retainers of connector holders are also securely installed)

STOP

Lock securely

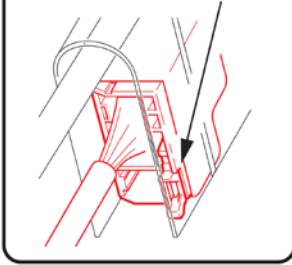

Make sure that connector is securely connected.

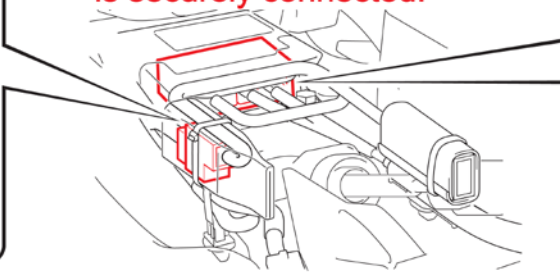

Lock securely

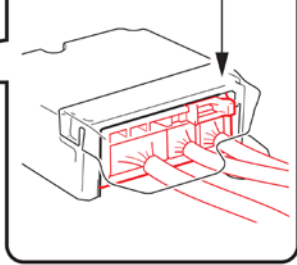

R2002120001h

Place the 2 cable ties at front side of the clamp

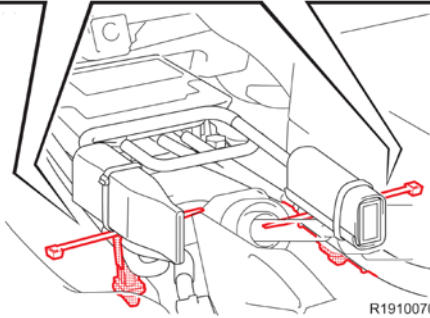
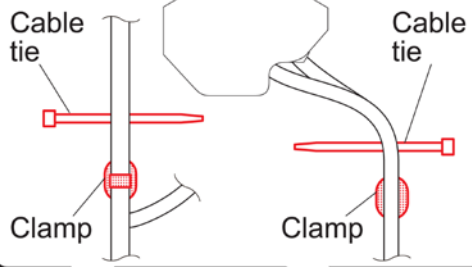

R1910070011ah

k) Place the 2 cable ties at front side of the clamp.

NOTE:

If you place the cable ties at wrong positions, the link connector and module cannot be fixed securely in later steps.

WITH REAR AIR DUCT ONLY

l) With Rear Air Duct:

- (1) Place the link connector on the instrument panel wire of the left side.
- (2) Using the cable tie passed through under the instrument panel wire of the left side, fix the link connector at around the center of convex part of the link connector.

NOTE:

- Make sure that the link connector, water guard sheet and instrument panel wire are securely fixed.
- Make sure that the water guard sheet is not flipped up.

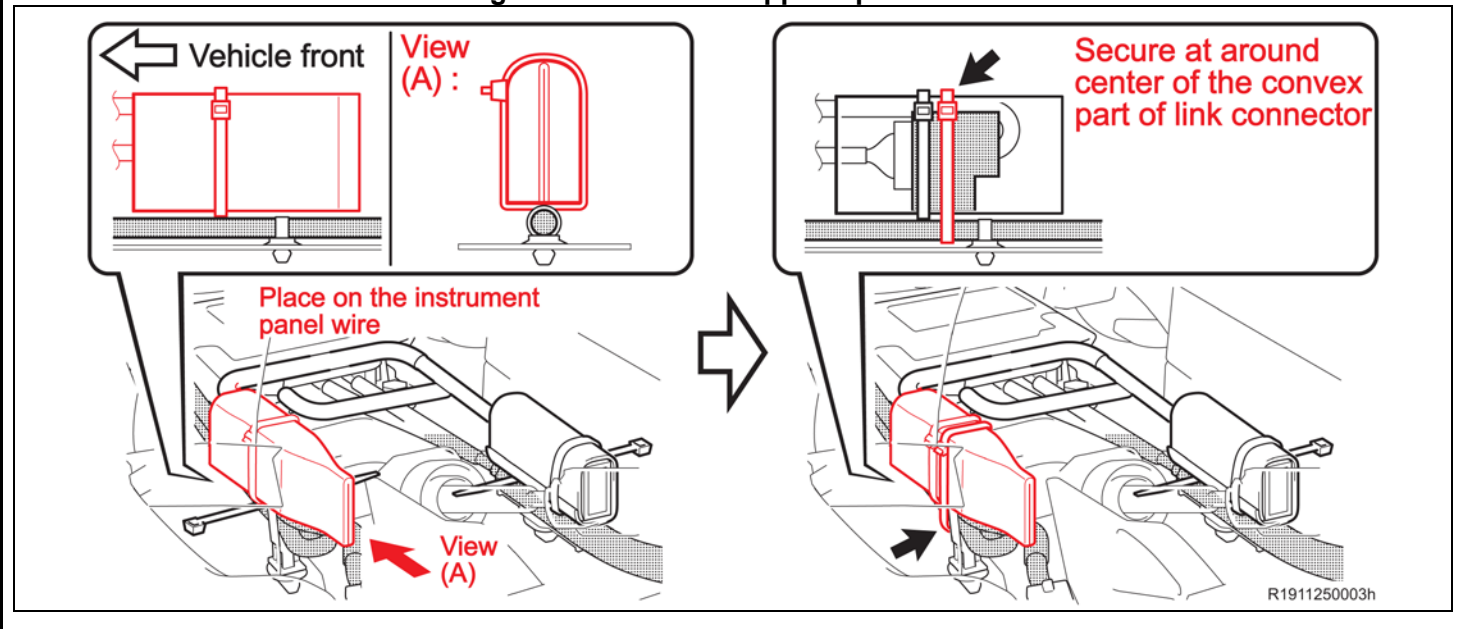

WITH REAR AIR DUCT ONLY

- (3) Link 2 cable ties in order to fix the link connector to the rear air duct LH.
- (4) Pass the linked cable tie through the positions shown below and temporarily install it.
 - Outside the rear air duct LH and the water guard sheet of the link connector
 - Between the instrument panel brace and rear air duct LH



Be careful not to include the uncovered part of the instrument panel wire on the vehicle left side when fixing the cable tie.

- (5) Fix the link connector with the cable tie as shown in the illustration.

NOTE:

- Make sure that the link connector, water guard sheet and instrument panel wire are securely fixed.
 - Make sure that the water guard sheet is not flipped up.
- (6) Cut off the excess of the cable tie.

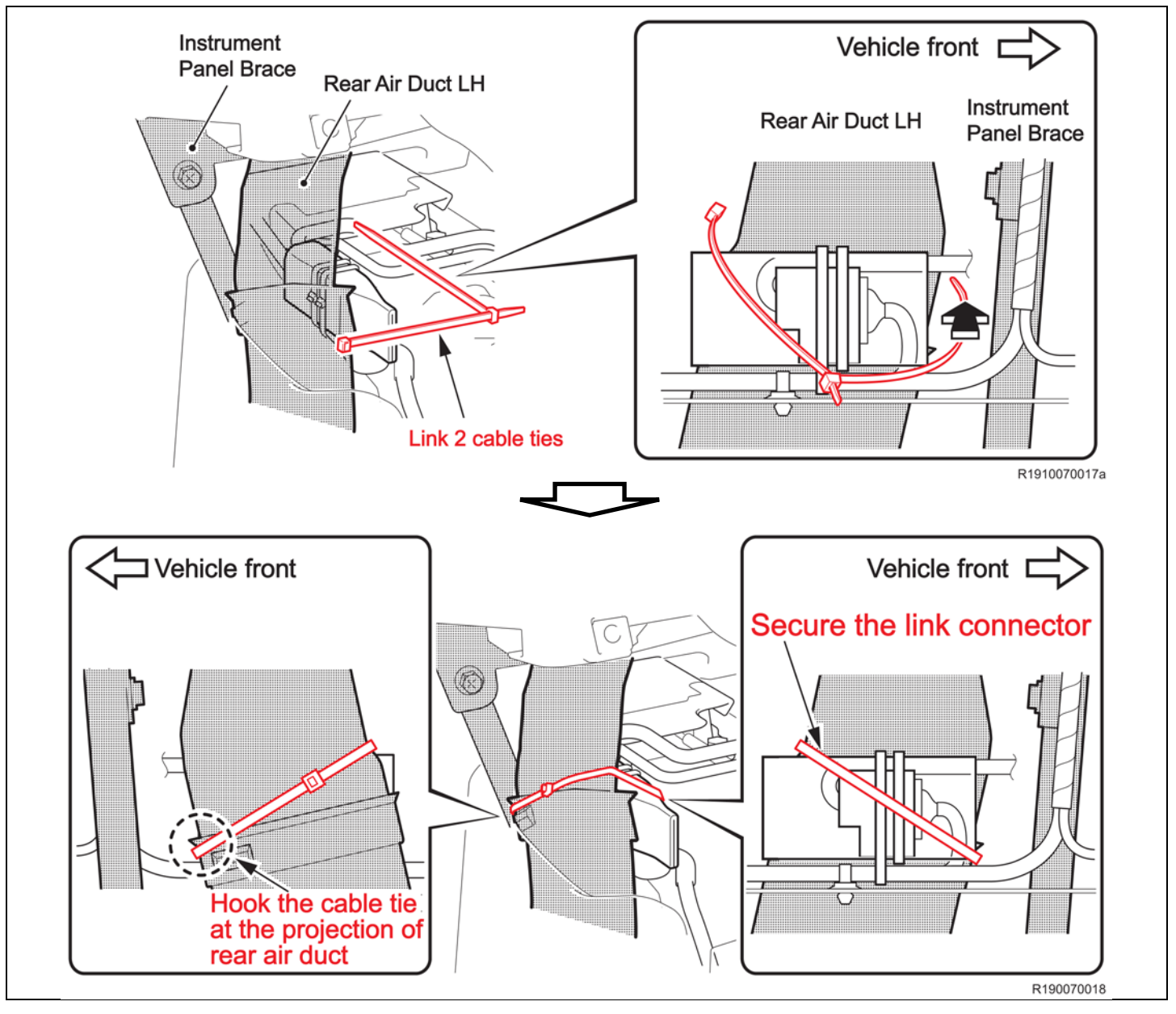

WITH REAR AIR DUCT ONLY

(7) Bend the module side of the airbag sub harness as shown in the illustration.

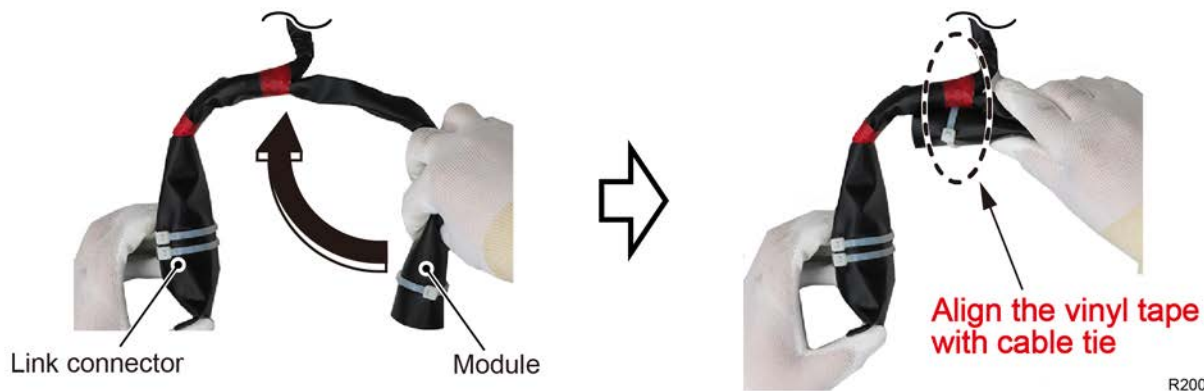

(8) Place the module on the instrument panel wire of the right side.

(9) Using the cable tie passed through under the instrument panel wire of the right side, fix the module at around its center.

NOTE:

- Make sure that the module, water guard sheet and instrument panel wire are securely fixed.
- Make sure that the water guard sheet is not flipped up.

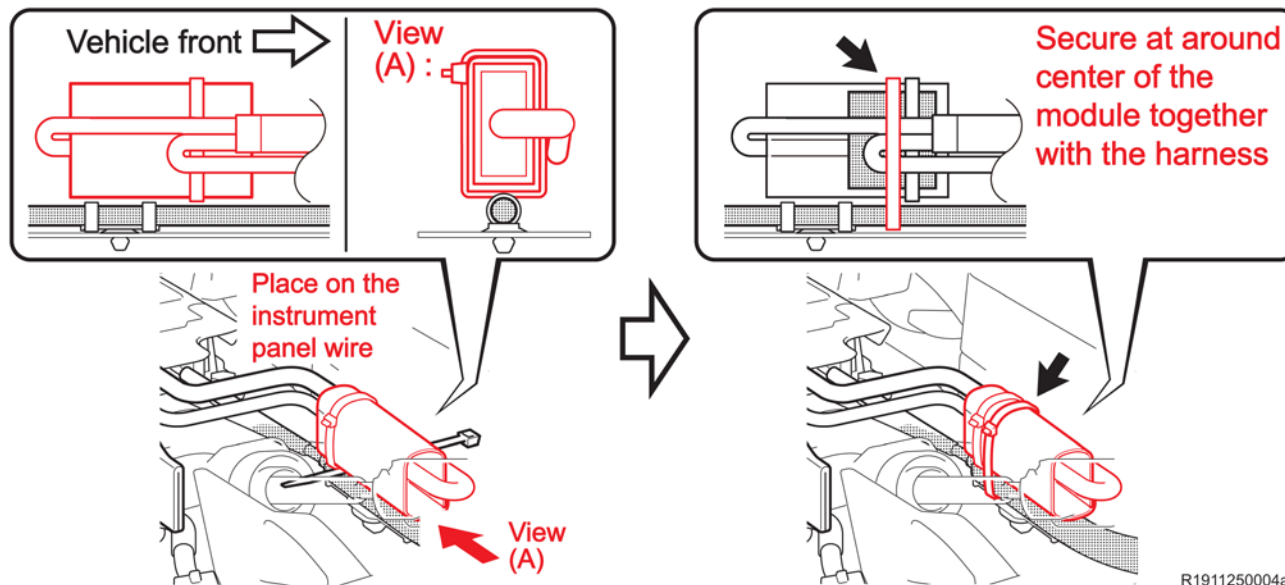

WITHOUT REAR AIR DUCT ONLY

l) Without Rear Air Duct:

- (1) Place the link connector outside the instrument panel wire of the left side.
- (2) Using the cable tie passed through under the instrument panel wire of the left side, fix the link connector at around the center of convex part of the link connector.

NOTE:

- Make sure that the link connector, water guard sheet and instrument panel wire are securely fixed.
- Make sure that the water guard sheet is not flipped up.

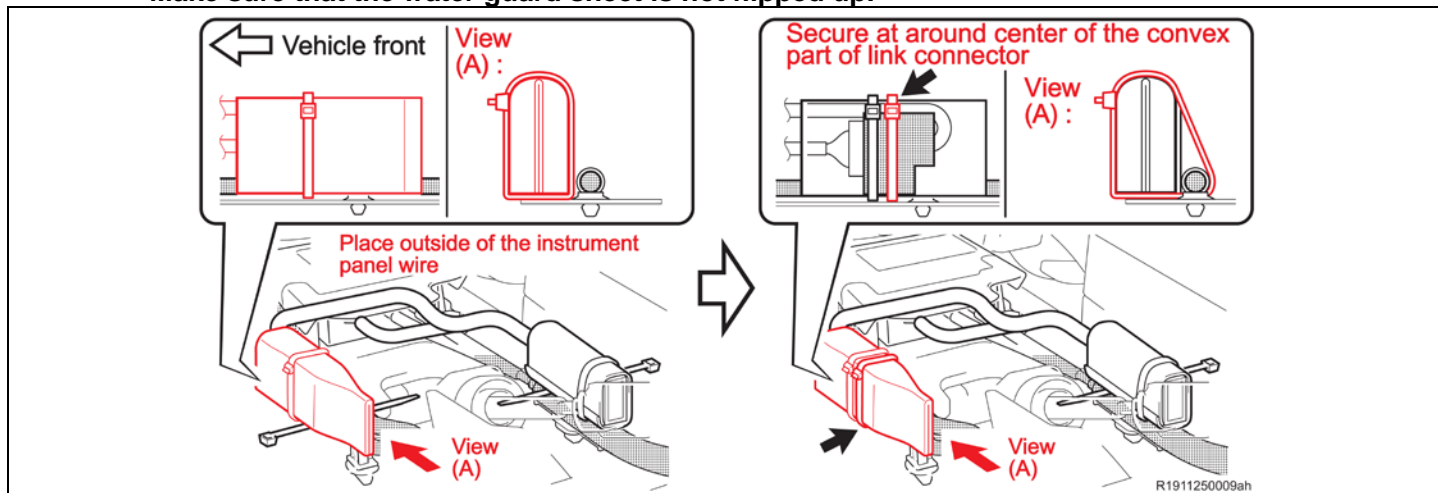

- (3) Bend the module side of the airbag sub harness as shown in the illustration.

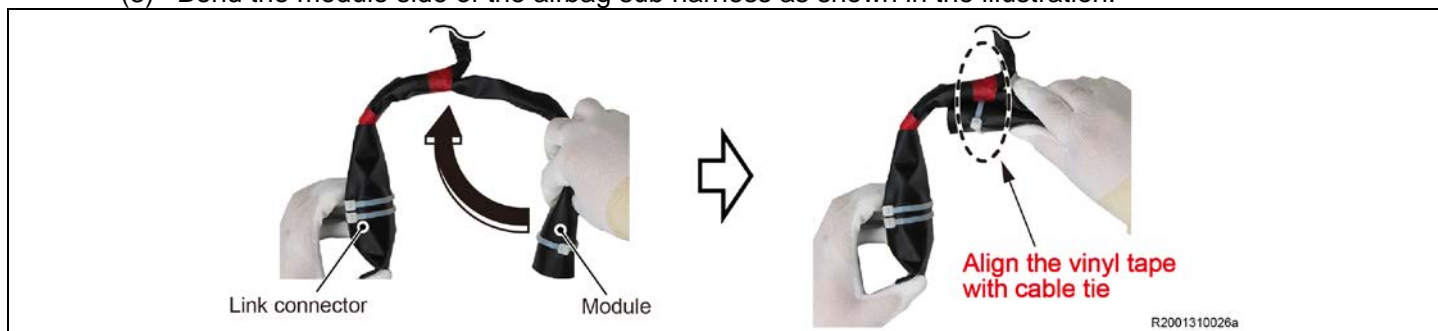

- (4) Place the module outside the instrument panel wire of the right side.
- (5) Using the cable tie passed through under the instrument panel wire of the right side, fix the module at around its center.

NOTE:

- Make sure that the module, water guard sheet and instrument panel wire are securely fixed.
- Make sure that the water guard sheet is not flipped up.

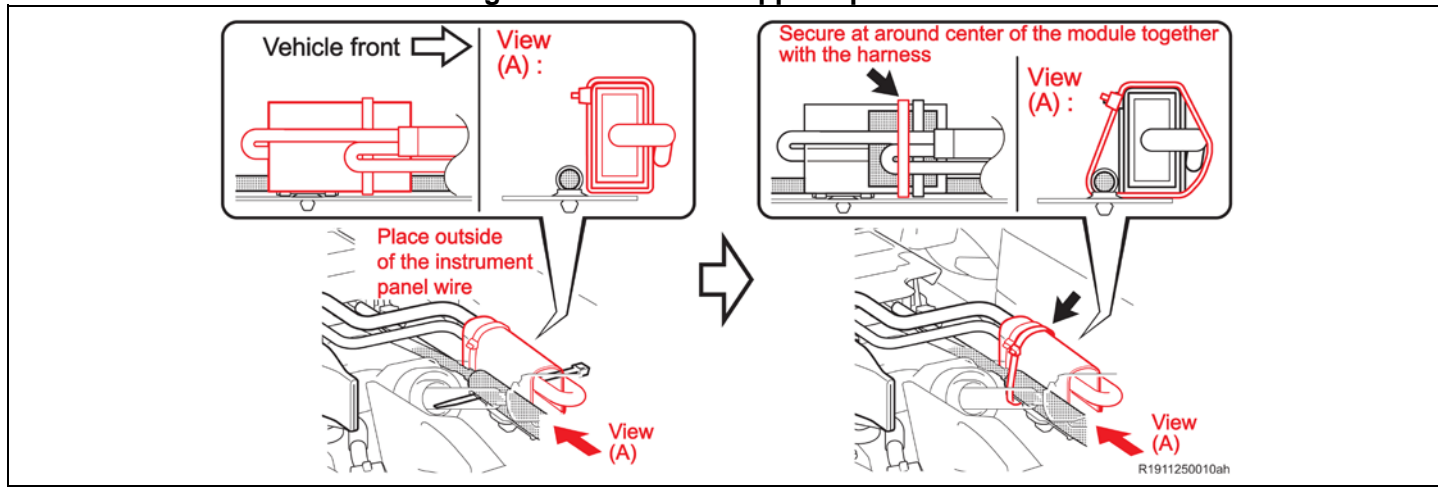

ALL VEHICLE TYPES

DO NOT tie up the cable tie excessively

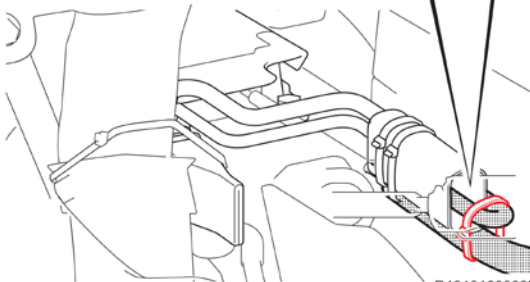
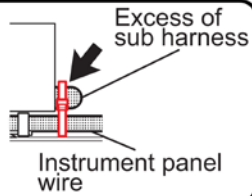

R1910180003h

*This illustration uses "w/ Rear Air Duct" for reference

Place the water guard sheet under the harness between link connector and module

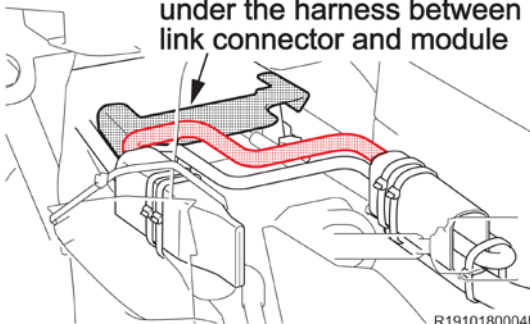

R1910180004h

*This illustration uses "w/ Rear Air Duct" for reference

Make sure there is no interference with the cable



R1911250005

- m) Using a cable tie, fix the excess harness of module side together with the instrument panel wire.



DO NOT tie up the cable tie excessively to avoid damage to the harness.

- n) Place the water guard sheet of the airbag ECU under the harness between the link connector and module.
- o) Make sure there is no interference with the shift cable.



INTERMEDIATE INSPECTION (BY ANOTHER WORKER)

Confirm airbag sub harness is installed in proper condition



- Check each water guard sheet is not flipped up.

OK

Not flipped up

NG

Flipped up

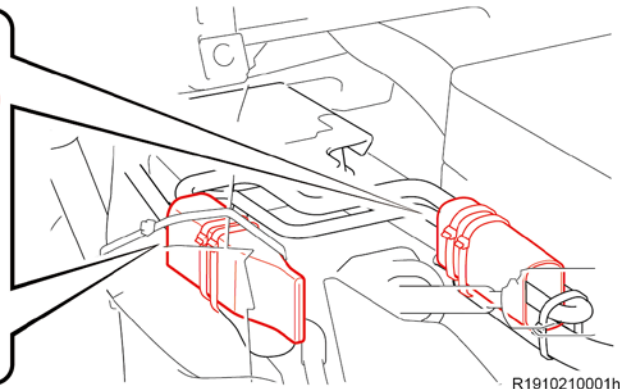

R1910210001h

- Check each cable tie is fixed at its proper position and is securely fixed.
- Check the cable tie is fixed properly and if it is installed loose, tighten up the cable tie. And then cut off the excess of the cable tie.

With Rear Air Duct:

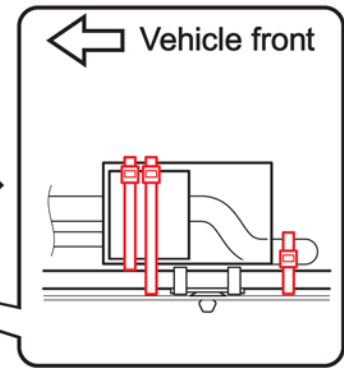
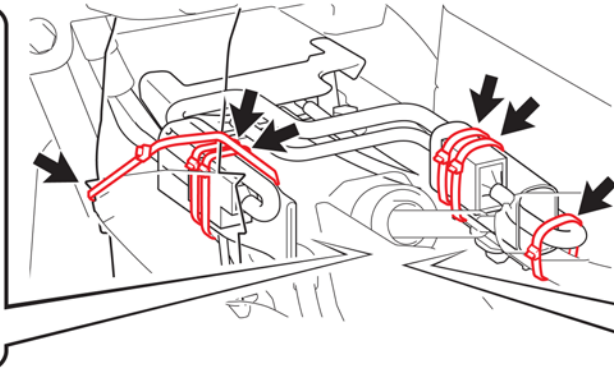
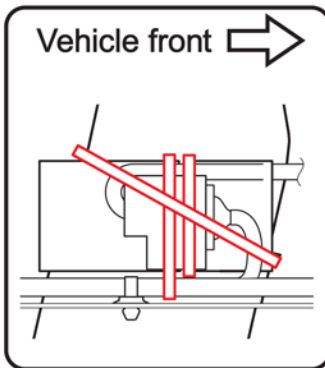

R1910220013h

Without Rear Air Duct:

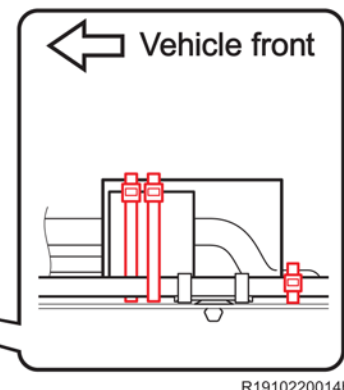
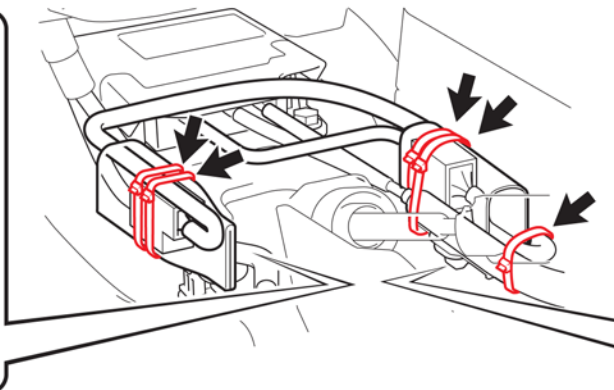
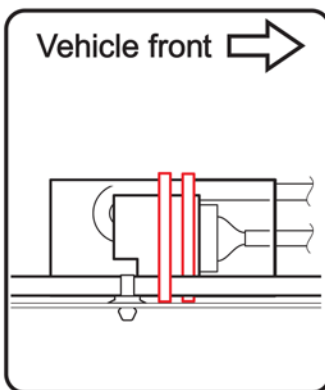

R1910220014h

TRW Wire Harness Repair

Dealer Code:

Password:

LOGIN

5. Post Repair Quality Checksheet

a. Login to the website below to complete the Post Repair Quality Checksheet

URL: <https://toyota-trw.imagespm.info/>

Login Cridentials

Username: Dealer code
 Password (1st time login): XXXXX

If you have any issues with the website contact Quality_Compliance@toyota.com for assistance.

Enter technician info.

Technician Name:

SPIN ID:

Certification Level:

Toyota Expert (Electrical)

NEXT

b. Enter the following information into the site

Technician Name
 Spin ID
 Select your current Toyota certification

c. Enter the VIN into the website

d. Upload a picture of the completed wire harness installation as instructed on the website.

NOTE: Example photo below shows vehicle with rear air ducts. Vehicles without rear air ducts will look slightly different.

 **The picture you take MUST MATCH the angle of image shown below**

Example picture



6. RESTORE THE VEHICLE

a. Click the link below to access TIS for instructions

[SUPPLEMENTAL RESTRAINT SYSTEMS: CENTER AIRBAG SENSOR ASSEMBLY: INSTALLATION; 2014 - 2019 MY Corolla](#) (Doc ID: RM100000009JTP)



Be careful not to pinch the airbag sub harness when installing the console box.

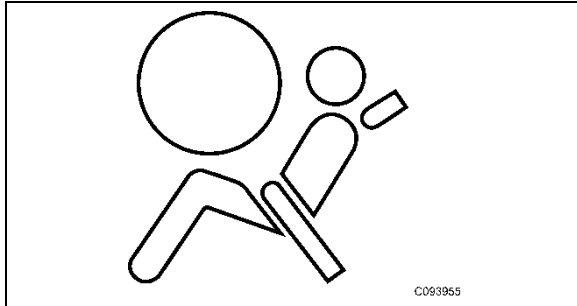

7. INSPECT SRS WARNING LIGHT

- Check that the airbag warning light lights when the power switch is turned on.
- Check that the airbag warning light goes off approximately 6 seconds after turning on of the ignition switch.

NOTE:

If the airbag warning light remains on, it is likely to be caused by connection failure of the airbag connector.

◀ VERIFY REPAIR QUALITY ▶

- Confirm there is no SRS light on
- Confirm center console has been properly installed and that no large gaps in trim are present
- Confirm you have completed the Repair Quality Checksheet and that the image you uploaded was correct.

If you have any questions regarding this Safety Recall, please contact your regional representative.

VII. APPENDIX

A. CAMPAIGN DESIGNATION DECODER

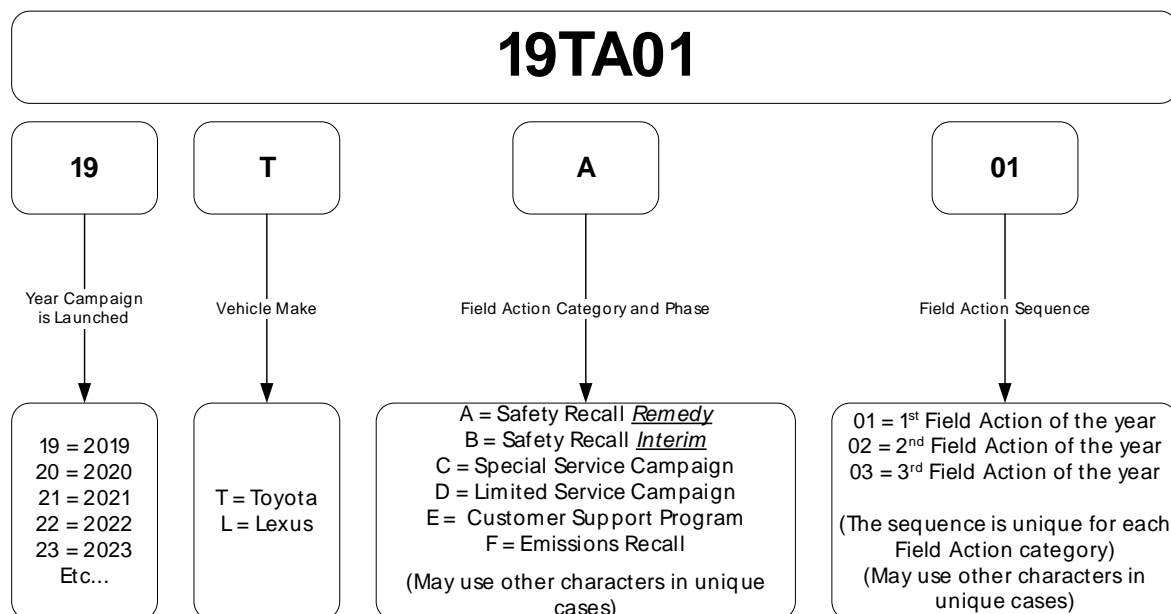

Examples:

19TA01 = Launched in 2019, Toyota, Safety Recall Remedy Phase, 1st Safety Recall Launched in 2019
 20TC02 = Launched in 2020, Special Service Campaign, 2nd Special Service Campaign Launched in 2020
 21TE05 = Launched in 2021, Customer Support Program, 5th Customer Support Program Launched in 2021