

TECHNICAL INSTRUCTIONS

FOR

SAFETY RECALL 20LA01

VEHICLE MAY STALL DURING DRIVING AT HIGHER SPEED

2018 - 2019 GS 300
2018 - 2019 GS 350
2018 - 2019 LC 500
2018 - 2019 LC 500h
2019 ES 350 (Japan Built)

2017 IS 200t
2018 - 2019 IS 300
2018 - 2019 IS 350
2014 IS F
2018 ES 350

2017 RC 200t
2018 - 2019 RC 300
2018 - 2019 RC 350
2018 - 2019 LS 500
2018 - 2019 LS 500h

The remedy for this campaign is being launched in phases. Confirm remedy eligibility on each VIN in TIS before starting any repairs.

Update 5/22/2020: Additional vehicle models have been added

Update 5/6/2020: Details of the NEW Cam Lock style campaign tool have been added

The repair quality of covered vehicles is extremely important to Lexus. All dealership technicians performing this recall are required to successfully complete the most current version of the E-Learning course "Safety Recall and Service Campaign Essentials". To ensure that all vehicles have the repair performed correctly; technicians performing this recall repair are required to currently hold at least one of the following certification levels:

- Certified
- Senior
- Master

It is the dealership's responsibility to select technicians with the above certification level or greater to perform this recall repair. Carefully review your resources, the technician skill level, and ability before assigning technicians to this repair. It is important to consider technician days off and vacation schedules to ensure there are properly trained technicians available to perform this repair at all times.

I. OPERATION FLOW CHART

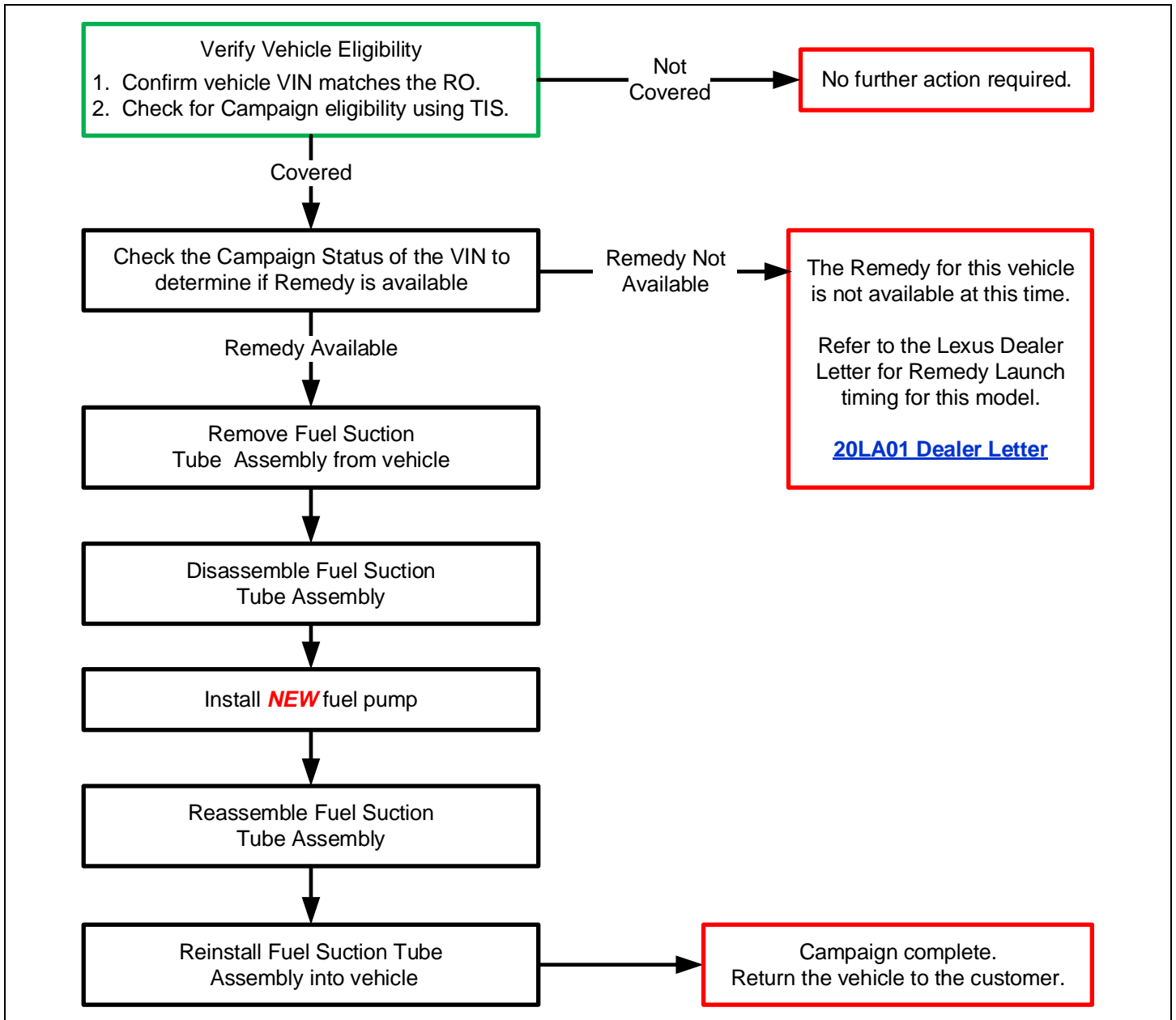

II. IDENTIFICATION OF AFFECTED VEHICLES

1. CHECK VEHICLE FOR CAMPAIGN ELIGIBILITY

- Compare the vehicle's VIN to the VIN listed on the Repair Order to ensure they match.
- Check the TIS Vehicle Inquiry System or Service Lane to verify this vehicle is eligible for Safety Recall 20LA01.
- Determine the **Campaign Status** for Safety Recall 20LA01.

Campaign Description: Safety Recall 20LA01 (Remedy Notice), Multiple
Campaign Status: ??????????
Completion Status: **Not Completed**

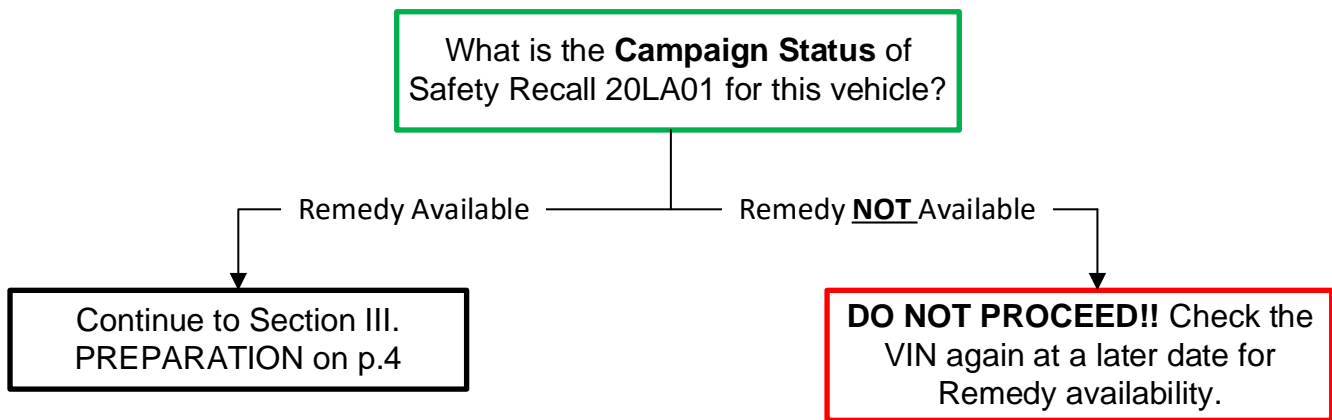

DO NOT PROCEED with these instructions if the Campaign Status shows Remedy Not Available!

The remedy for this campaign is being launched in phases. Confirm remedy eligibility on each VIN in TIS before starting any repairs.

Launch timing specific to each model is available in the [20LA01 Dealer Letter](#).

Note: Warranty will not reimburse dealers for repairs completed on vehicles that are not affected or were previously completed, even by another dealer. In addition, warranty claims will not be processed for vehicles that are not yet eligible for the remedy.

III. PREPARATION

A. PARTS

Because of the extensive list of parts for the numerous models affected by this Safety Recall, a website has been created to detail the required parts for each vehicle. Reference the following website for a detailed parts list for **each specific VIN**:

<https://201a01.imagespm.info>

Note: Warranty will only reimburse dealers for the part numbers listed on the website. Any other part numbers will not be accepted on the campaign claim.

B. TOOLS & EQUIPMENT

- Standard Hand Tools
- Torque Wrench
- Air Blow gun
- Gas Caddy (minimum 25-gallon capacity)

C. MATERIALS

- Brake Cleaner

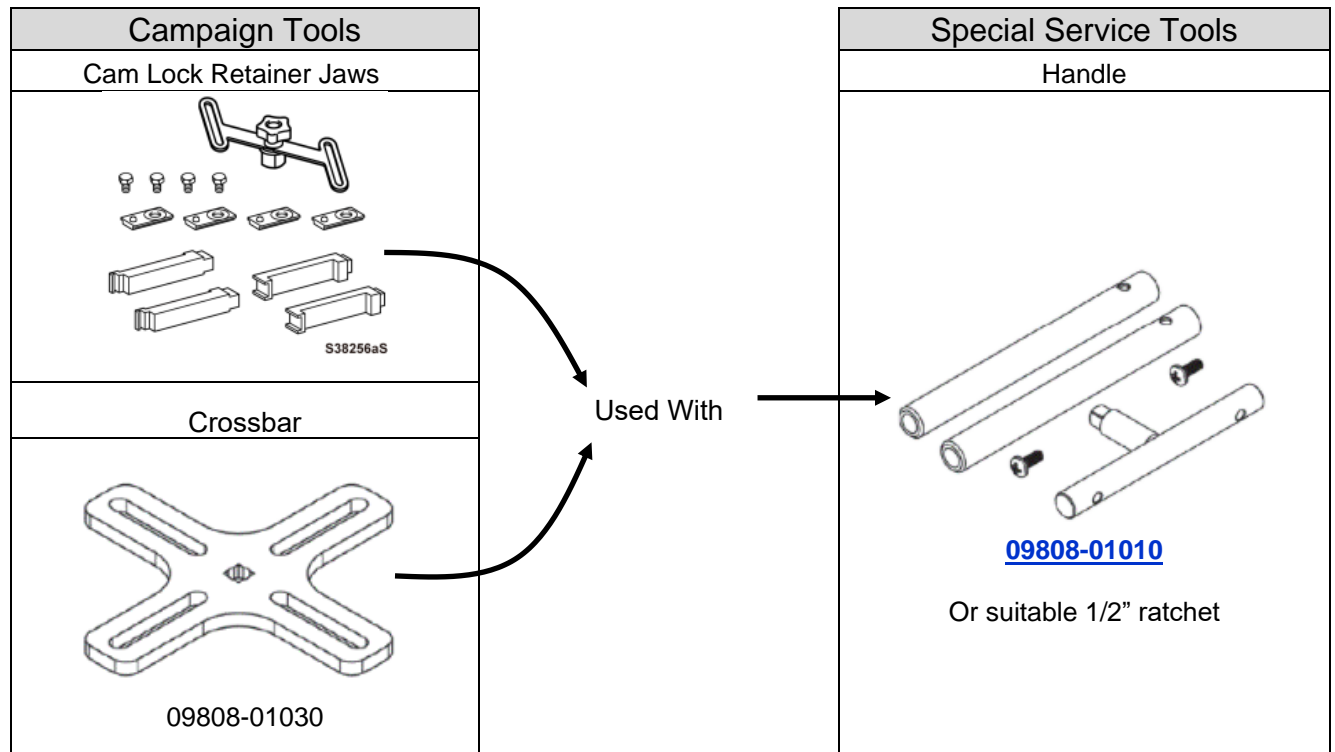

D. CAMPAIGN TOOLS

Each dealership will be provided a Crossbar and a set of Cam Lock Retainer Jaws for removing the Cam Lock type retainer rings. These jaws will be used with the dealerships existing Handle set from the Fuel Sender Lock Nut Wrench Set (09808-14031). A 1/2" breaker bar can also be used. This set of tools will supplement the SST kit that each dealership currently has. Additional SST's can be purchased through the [Lexus Special Service Tools \(SST\)](#) website.



C. Special Service Tools

In the affected models, there are four different types of Fuel Pump Retainer Rings. Reference the following chart to determine the proper tool for removal.

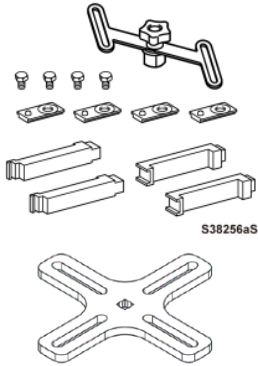
		RETAINER TYPE	
		<u>Bolt In</u>	<u>Cam Lock</u>
Type:			
SST:	No SST Required		 Fuel Sender Lock Nut Wrench Kit (09808-14031) Claw: 105mm Jaw Set (09808-01070) Crossbar (09808-01030)
Special Notes:			<u>Campaign Tool:</u> Cam Lock Retainer Jaws  Requires use of the Handle from the Fuel Sender Lock Nut Wrench Kit, or a 1/2" breaker bar.
Models:	ES 350 (2018) LC 500/500h LS 500/500h IS-F		ES 350 (2019) GS 300/350 IS 200t/300/350 RC 200t/300/350

Additional SST's can be purchased from the [Lexus Special Service Tools](#) (SST) website

IV. BACKGROUND

The subject vehicles are equipped with a low-pressure fuel pump which may stop operating. If this were to occur, warning lights and messages may be displayed on the instrument panel, and the engine may run rough. This may result in a vehicle stall, and the vehicle may be unable to be restarted. If a vehicle stall occurs while driving at higher speeds, this could increase the risk of a crash.

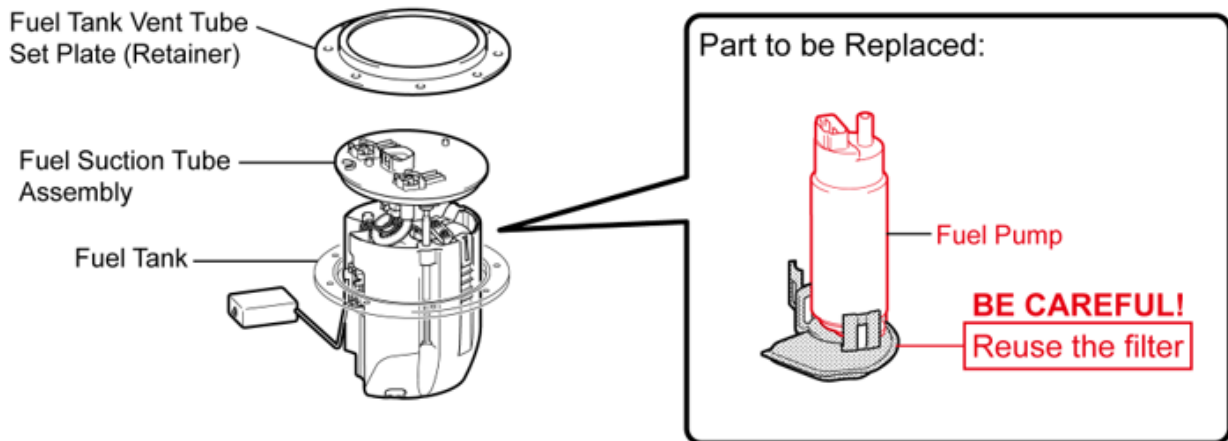

*The configuration of the parts will differ depending on the specification.

S38182aSU

V. SAFETY PRECAUTIONS

CAUTION:

- When installing/uninstalling the fuel system components, keep safety first in mind and carefully observe the following instructions to avoid accidents:
- a. When working on the fuel system, display a Flammable - Keep Fire Away sign.
 - b. Smoking is prohibited nearby.
 - c. Perform this work in an area where there are no sparks nearby from the operation of welders, grinders, drills, electric motors, stoves, etc.
 - d. **DO NOT** use electrical devices nearby because they can become hot and the operation of power switches can generate sparks.
 - e. **DO NOT** use iron or steel hammers while working, because they may generate sparks.
 - f. **DO NOT** start engines even in adjacent stalls.
 - g. Prepare fire extinguishers before starting any work.
 - h. Perform this work in a well-ventilated area (natural ventilation). **DO NOT** use exhaust fans or electric fans, because their motors might generate sparks.
 - i. Since it is possible for fuel vapor to build up, **DO NOT** work in or near a pit.
 - j. If fuel is spilled, use shop towels or similar material to quickly wipe it up and then use compressed air to diffuse the fuel vapor.
 - k. Shop towels and other materials that have come into contact with fuel should be dried in a well-ventilated area and then disposed of as appropriate.

VI. COMPONENTS

ES 350 2019 (VINs starting JTH)

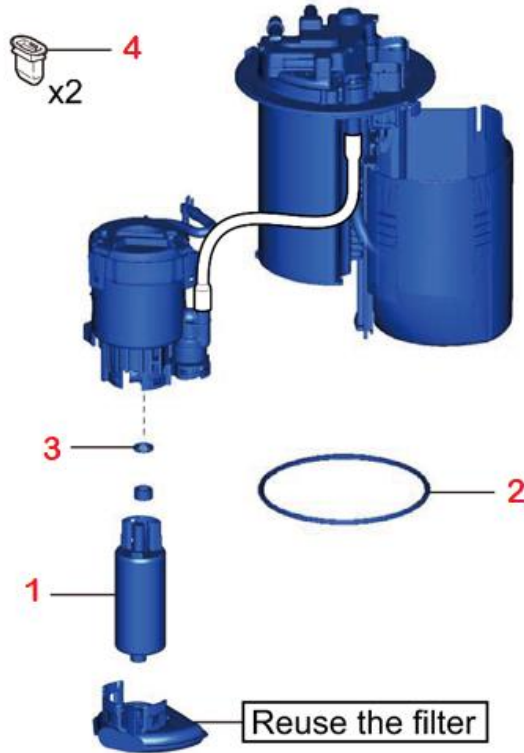

Replacement Items in red

No.	Contents of Part Kit's	Quantity	Tape Color	Remarks
1	FUEL PUMP	1		
2	FUEL SUCTION TUBE SET GASKET	1		
3	O-RING	2*	GOLD	15.2mm
4	REAR SEAT CUSHION LOCK HOOK	2		
5	O-RING	1	RED	Not used
6	O-RING	1	GREEN	Not used
7	FUEL TANK PIPE SETTING HOLDER	1	WHITE	Not used

*only 1 O-Ring will be used. Discard the 2nd O-Ring.

DO NOT order the individual parts listed here. It is provided as a reference to assist in the correct installation. Order the parts kit's specific to each VIN, as detailed in the parts lookup website (p. 4). Warranty will only reimburse dealers for the part numbers listed on the website. Any other part numbers will not be accepted on the campaign claim.

Note: Some items in the Fuel Pump Replacement Kit will not be used.

Parts Kit items not used

5-● 6-● 7-→

ES 350 **2018**

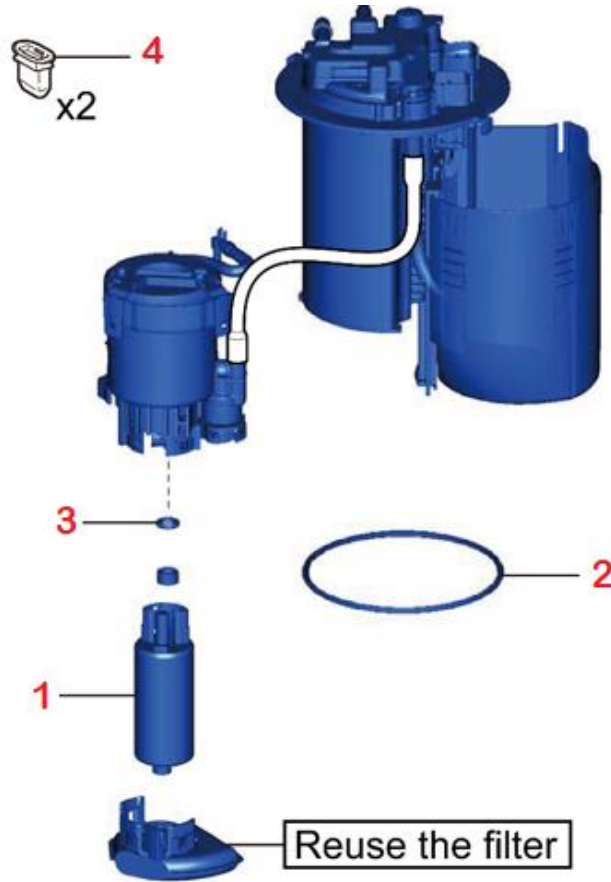

Replacement items in red

No.	Contents of Part Kit's	Quantity	Tape Color	Remarks
1	FUEL PUMP	1		
2	FUEL SUCTION TUBE SET GASKET	1		
3	O-RING	2*	YELLOW	15.2mm
4	REAR SEAT CUSHION LOCK HOOK	2		
5	O-RING	1	RED	Not used
6	O-RING	1	GREEN	Not used
7	FUEL TANK PIPE SETTING HOLDER	1	WHITE	Not used

*only 1 O-Ring will be used. Discard the 2nd O-Ring.

DO NOT order the individual parts listed here. It is provided as a reference to assist in the correct installation. Order the parts kit's specific to each VIN, as detailed in the parts lookup website (p. 4). Warranty will only reimburse dealers for the part numbers listed on the website. Any other part numbers will not be accepted on the campaign claim.

Note: Some items in the Fuel Pump Replacement Kit will not be used.

Parts Kit items not used

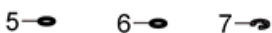

GS 300 / GS 350

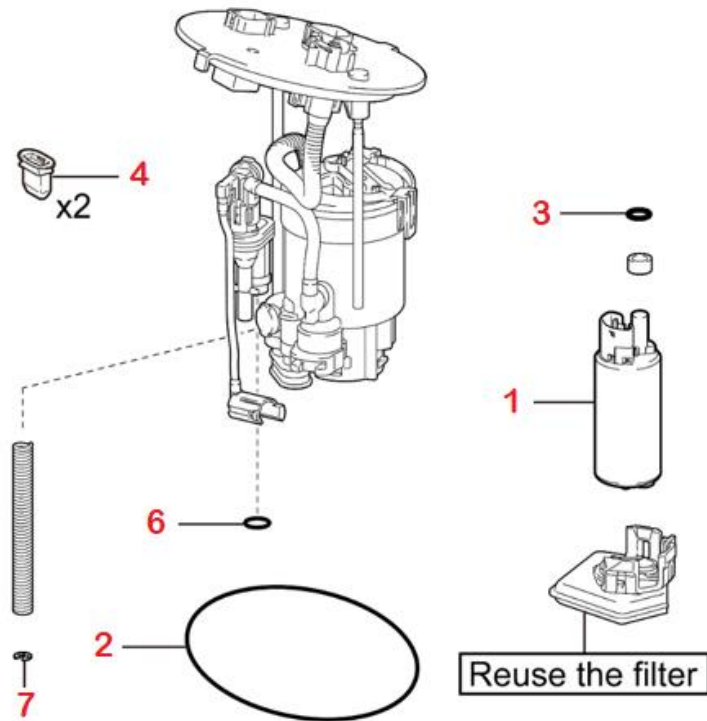

Replacement items in red

No.	Contents of Part Kit's	Quantity	Tape Color	Remarks
1	FUEL PUMP	1		
2	FUEL SUCTION TUBE SET GASKET	1		
3	O-RING	2*	GOLD	15.2mm
4	REAR SEAT CUSHION LOCK HOOK	2		
5	O-RING	1	RED	Not used
6	O-RING	1	GREEN	16.4mm
7	FUEL TANK PIPE SETTING HOLDER	1	WHITE	

*only 1 O-Ring will be used. Discard the 2nd O-Ring.

DO NOT order the individual parts listed here. It is provided as a reference to assist in the correct installation. Order the parts kit's specific to each VIN, as detailed in the parts lookup website (p. 4). Warranty will only reimburse dealers for the part numbers listed on the website. Any other part numbers will not be accepted on the campaign claim.

Note: Some items in the Fuel Pump Replacement Kit will not be used.

Parts Kit items not used

5—

IS 200t / IS 300 / IS 350

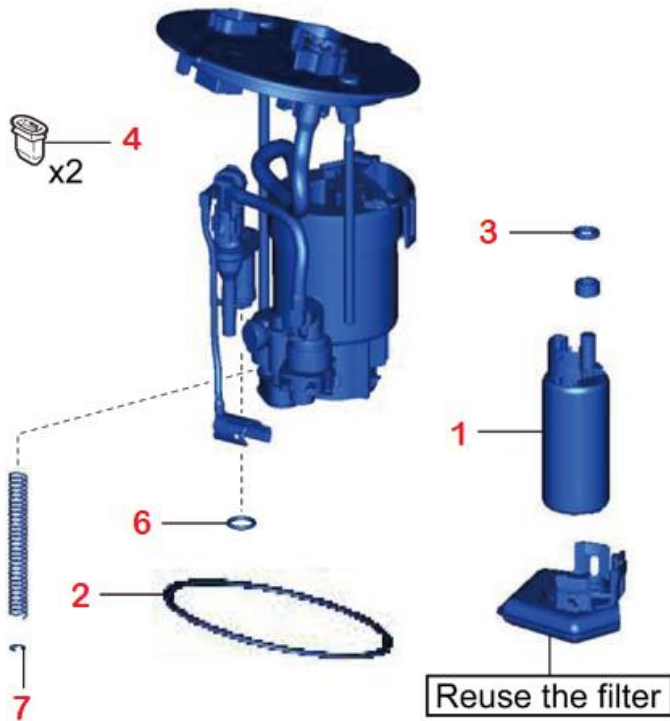

Replacement items in red

No.	Contents of Part Kit's	Quantity	Tape Color	Remarks
1	FUEL PUMP	1		
2	FUEL SUCTION TUBE SET GASKET	1		
3	O-RING	2*	GOLD	15.2mm
4	REAR SEAT CUSHION LOCK HOOK	2		
5	O-RING	1	RED	Not used
6	O-RING	1	GREEN	16.4mm
7	FUEL TANK PIPE SETTING HOLDER	1	WHITE	

*only 1 O-Ring will be used. Discard the 2nd O-Ring.

DO NOT order the individual parts listed here. It is provided as a reference to assist in the correct installation. Order the parts kit's specific to each VIN, as detailed in the parts lookup website (p. 4). Warranty will only reimburse dealers for the part numbers listed on the website. Any other part numbers will not be accepted on the campaign claim.

Note: Some items in the Fuel Pump Replacement Kit will not be used.

Parts Kit items not used



IS-F

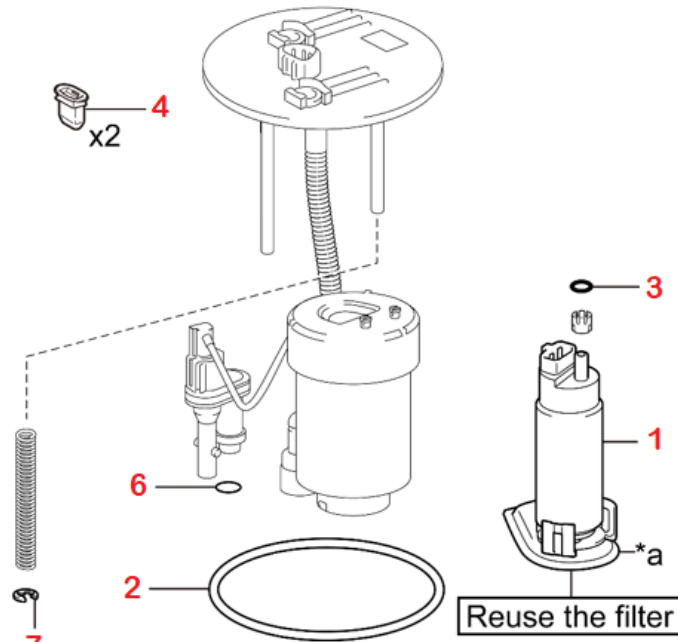

Replacement items in red

No.	Contents of Part Kit's	Quantity	Tape Color	Remarks
1	FUEL PUMP	1		
2	FUEL SUCTION TUBE SET GASKET	1		
3	O-RING	2*	Gold	15.2mm
4	REAR SEAT CUSHION LOCK HOOK	4**		2 needed
5	O-RING	1	Red	Not used
6	O-RING	1	Green	16.4mm
7	FUEL TANK PIPE SETTING HOLDER	1	White	

*only 1 O-Ring will be used. Discard the 2nd O-Ring.

**only 2 rear seat lock hooks are needed. Discard the other 2.

DO NOT order the individual parts listed here. It is provided as a reference to assist in the correct installation. Order the parts kit's specific to each VIN, as detailed in the parts lookup website (p. 4). Warranty will only reimburse dealers for the part numbers listed on the website. Any other part numbers will not be accepted on the campaign claim.

Note: Some items in the Fuel Pump Replacement Kit will not be used.

Parts Kit items not used

5—●

LC 500 / LC 500h
 LS 500 / LS 500h

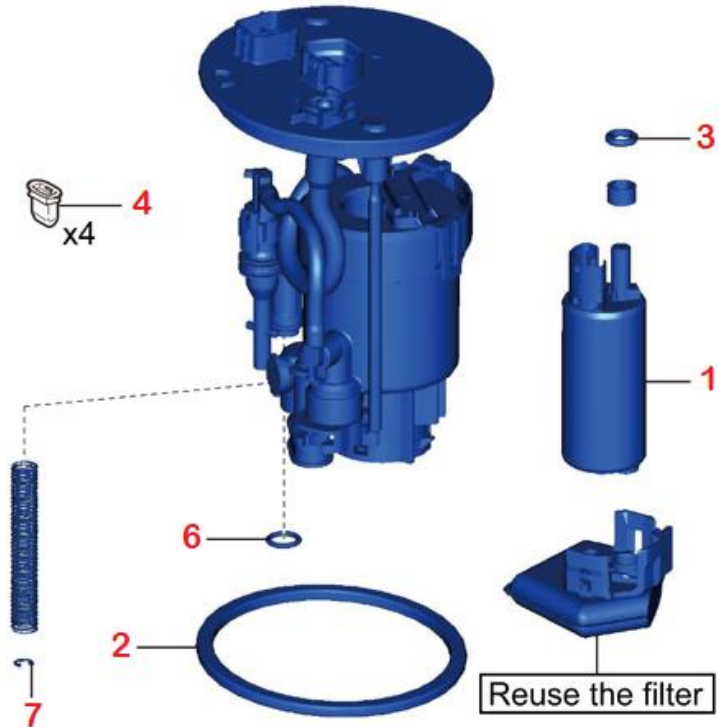

Replacement items in red

No.	Contents of Part Kit's	Quantity	Tape Color	Remarks
1	FUEL PUMP	1		
2	FUEL SUCTION TUBE SET GASKET	1		
3	O-RING	2*	Gold	15.2mm
4	REAR SEAT CUSHION LOCK HOOK	4**		varies
5	O-RING	1	Red	Not used
6	O-RING	1	Green	16.4mm
7	FUEL TANK PIPE SETTING HOLDER	1	White	

*only 1 O-Ring will be used. Discard the 2nd O-Ring.

** LS 500/500h: Fixed rear seat will use 3 pieces. Power rear seat will use 2 pieces.

** LC 500/500h: Only 2 rear seat lock hooks are needed. Discard the other 2.

DO NOT order the individual parts listed here. It is provided as a reference to assist in the correct installation. Order the parts kit's specific to each VIN, as detailed in the parts lookup website (p. 4). Warranty will only reimburse dealers for the part numbers listed on the website. Any other part numbers will not be accepted on the campaign claim.

Note: Some items in the Fuel Pump Replacement Kit will not be used.

Parts Kit items not used

5—

RC 200t / RC 300 / RC 350

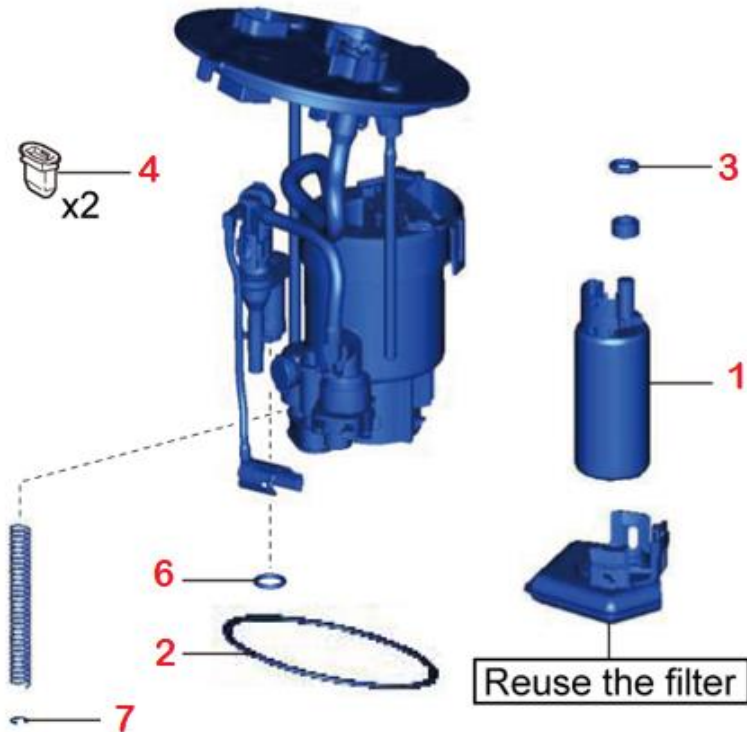

Replacement items in red

No.	Contents of Part Kit's	Quantity	Tape Color	Remarks
1	FUEL PUMP	1		
2	FUEL SUCTION TUBE SET GASKET	1		
3	O-RING	2*	GOLD	15.2mm
4	REAR SEAT CUSHION LOCK HOOK	2		
5	O-RING	1	RED	Not used
6	O-RING	1	GREEN	16.4mm
7	FUEL TANK PIPE SETTING HOLDER	1	WHITE	

*only 1 O-Ring will be used. Discard the 2nd O-Ring.

DO NOT order the individual parts listed here. It is provided as a reference to assist in the correct installation. Order the parts kit's specific to each VIN, as detailed in the parts lookup website (p. 4). Warranty will only reimburse dealers for the part numbers listed on the website. Any other part numbers will not be accepted on the campaign claim.

Note: Some items in the Fuel Pump Replacement Kit will not be used.

Parts Kit items not used

5—●

VII. REMOVE FUEL TUBE ASSEMBLY



Use TIS to confirm that this vehicle is eligible for the campaign before proceeding (p. 3). Warranty will not pay claims on ineligible vehicles.



1. CHECK FOR DTC'S

- a. Using a Techstream, perform a Health Check to check for Diagnostic Trouble Codes.

Note: *This Safety Recall covers only the replacement of the fuel pump and associated parts. It does not cover the diagnosis or replacement of any other parts on the vehicle.*

DISASSEMBLY TIP: FOLLOW THE REPAIR MANUAL

The Part's Kit contains the necessary O-Rings for reassembly, if the Repair Manual procedure is followed. If the pump components are disassembled in a manor other than as detailed in the Repair Manual, the Parts Kit may not contain the necessary O-Rings for proper reassembly. Please follow the procedures in the Repair Manual to ensure the correct O-Rings are available.

DISASSEMBLY TIP: FUEL LEVEL

If the fuel level inside the fuel tank is above the specified level, fuel may overflow from the fuel tank during the removal of the fuel suction tube assembly. Confirm the fuel level in the vehicle is below the specified level before proceeding. If necessary, drain fuel from the tank.

Model	FUEL LEVEL RECOMMENDATIONS	
	Less than full	1/3 or less
ES 350	✓	
GS 200t/300/350 IS 200t/300/350 IS-F LC 500/500h LS 500/500h RC200t/300/350		✓

Note: If fuel needs to be removed from the tank, be sure to recover it into an approved fuel recovery system. Suitable systems are available from the [Lexus Approved Dealer Equipment website](#).

DISASSEMBLY TIP: CAM LOCK RETAINER

An updated set of Cam Lock Claws and Support Columns are being supplied to each dealership for this campaign. The configuration of the retainer engagement sections of the claws have been modified from the SST that is referenced in the repair manual. The **NEW** claws have an improved design that enables a firm attachment to the retainer. In addition, 2 support columns are provided which will support the retainer more securely during installation and removal. Be sure to assemble and use the tools using the following procedures:

Campaign Tool Cam Lock Set:

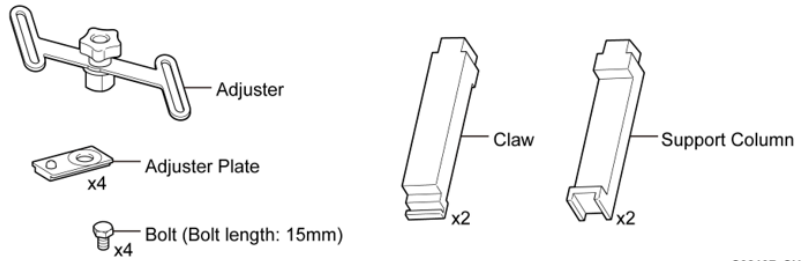

S38197aSU

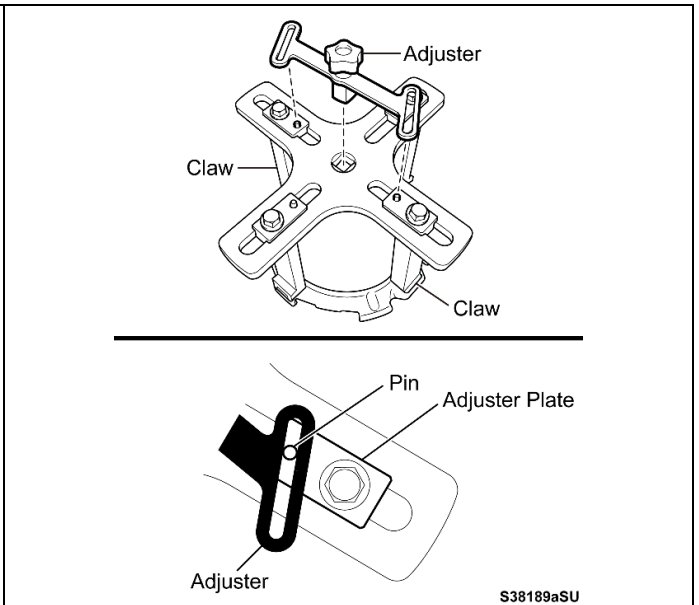
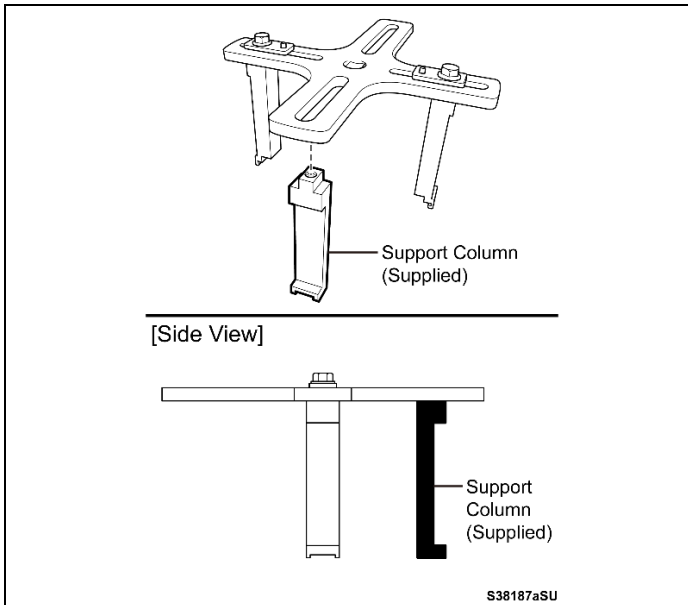
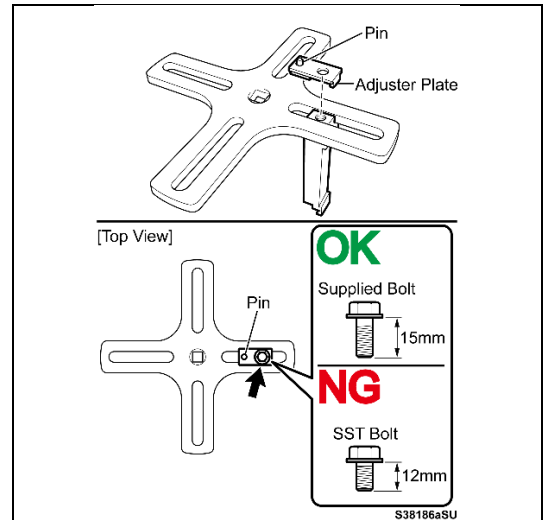
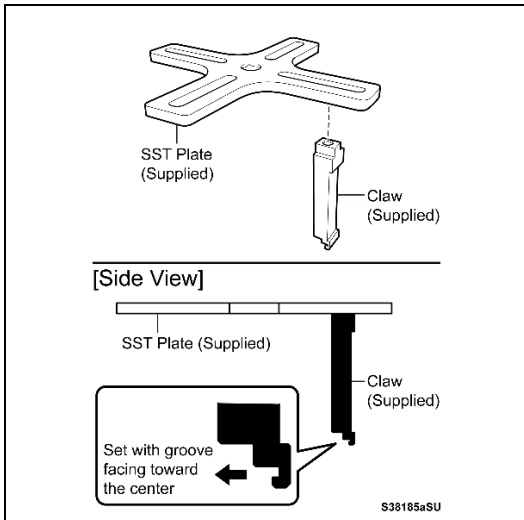

DISASSEMBLY TIP: CAM LOCK RETAINER (cont.)

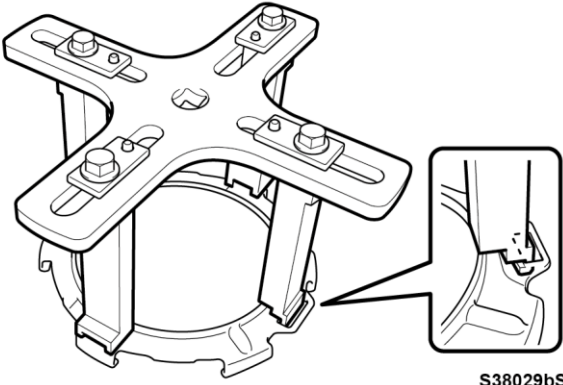

S38029bS

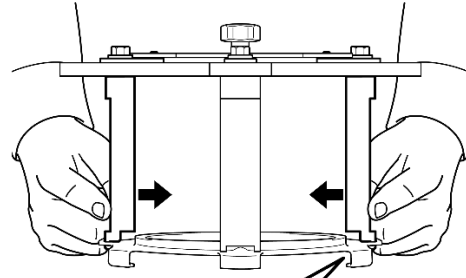

Push the claw inward firmly.

Check that the claw is engaging with the retainer.

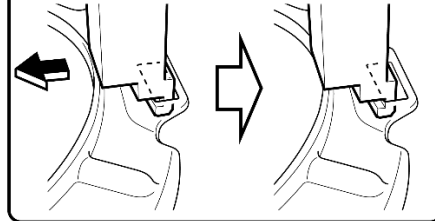

S38190aSU

OK

NG

NG

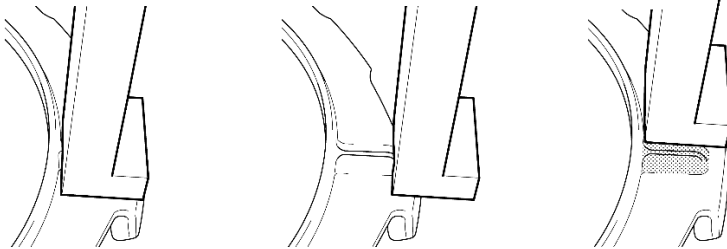

S38192aSU

Lightly tighten the adjuster

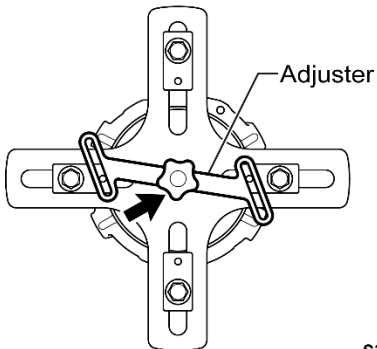

S38194aSU

Fully tighten the 4 bolts

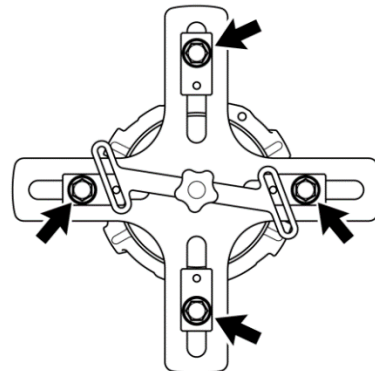

S38034aO

DISASSEMBLY TIP: TUBE ASSY ALIGNMENT

For vehicles with the plastic retainer rings, place matchmarks on both the Fuel Tube Assembly and the fuel tank. During disassembly, confirm that the Fuel Tube Assembly does not rotate. **Damage to the fuel level float arm could occur** if the Fuel Tube Assembly is allowed to rotate during disassembly or reassembly. During reassembly, this will aid in aligning the locating tabs for proper installation.

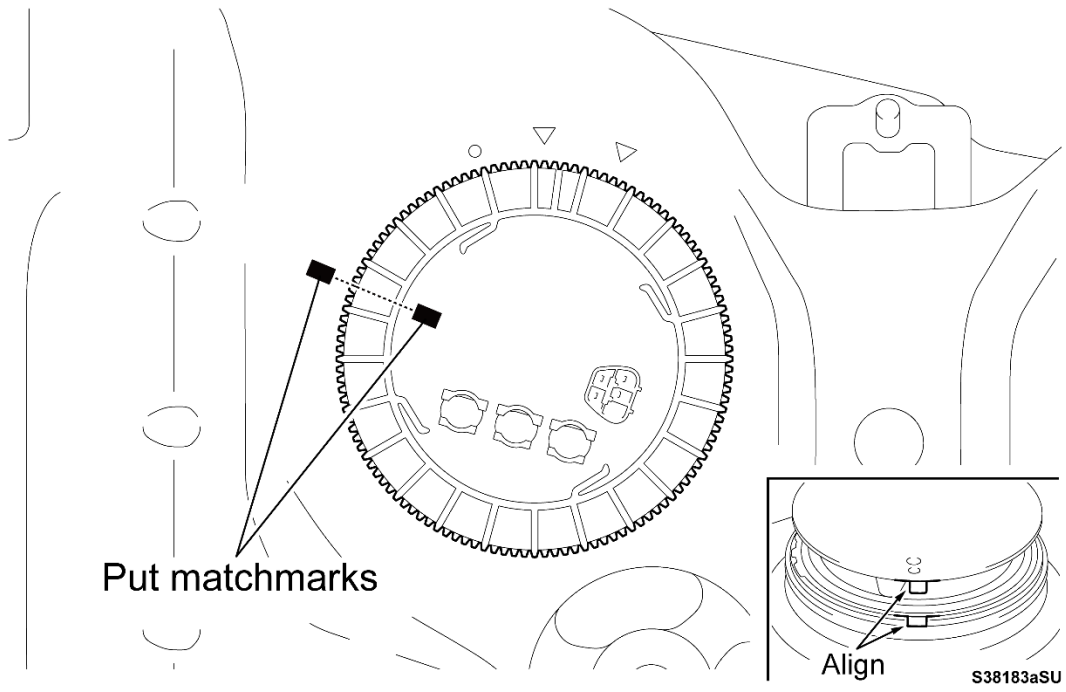

2. REMOVE FUEL TUBE ASSEMBLY FROM VEHICLE

- a. Follow the Repair Manual instructions to remove the Fuel Tube Assembly from the vehicle.

REMOVE FUEL TUBE ASSY.						
ES 350	2018	2019		IS 300	2018	2019
LC 500	2018	2019		IS 350	2018	2019
LC 500h	2018	2019		LS 500	2018	2019
GS 300	2018	2019		LS 500h	2018	2019
GS 350	2018	2019		IS 200t	2017	
RC 300	2018	2019		IS-F	2014	
RC 350	2018	2019		RC 200t	2017	

VIII. REMOVE FUEL PUMP FROM TUBE ASSEMBLY

DISASSEMBLY TIP: MAIN VALVE AND REGULATOR

When replacing the fuel pump, it is not necessary to remove the Fuel Main Valve or Fuel Pressure Regulator. The O-Rings are NOT included in the parts kit.

DO NOT remove

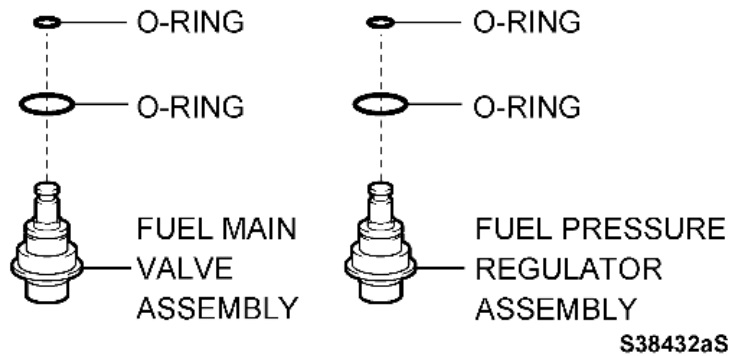

DISASSEMBLY TIPS: FUEL FILTER

Many of the models will require the fuel filter to be reused. Be careful with the tabs when removing the filter from the original fuel pump as to not overextend them. When installing the filter on the **NEW** Fuel Pump, be sure that the clips have engaged properly.

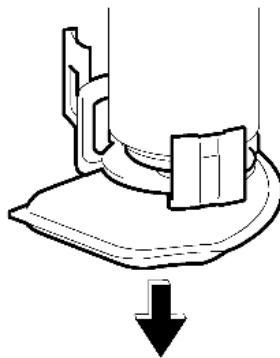

S38062aS

1. DISASSEMBLE FUEL SUCTION TUBE ASSEMBLY

a. Follow the Repair Manual instructions to disassemble the Fuel Suction Tube Assembly.

DISASSEMBLE						
ES 350	2018	2019		IS 300	2018	2019
LC 500	2018	2019		IS 350	2018	2019
LC 500h	2018	2019		LS 500	2018	2019
GS 300	2018	2019		LS 500h	2018	2019
GS 350	2018	2019		IS 200t	2017	
RC 300	2018	2019		IS-F	2014	
RC 350	2018	2019		RC 200t	2017	

2. CLEAN SUB TANK ASSEMBLY

a. Using brake cleaner, clean the sub-tank assembly.

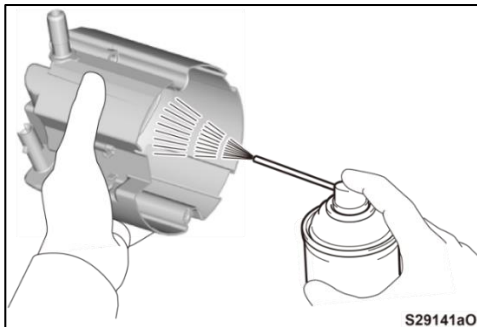

IX. REASSEMBLE FUEL TUBE ASSEMBLY

REASSEMBLY TIPS: O-RINGS

The part kits may come with O-Rings of different sizes. They are very difficult to tell apart visually. To identify the different size O-Rings, they will be wrapped in individual plastic bags with a piece of **COLORED TAPE** sealing it. The **COLOR OF THE TAPE** will identify the O-Ring size. **REFER TO THE COMPONENT DIAGRAMS TO DETERMINE TO CORRECT O-RING**, as identified by the tape color.

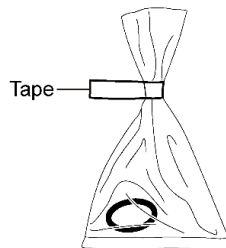

1. CONFIRM PARTS

- Using the part lookup website, input the VIN number to confirm that you have the proper parts for this vehicle:

<https://201a01.imagespm.info>

2. REASSEMBLE FUEL SUCTION TUBE ASSEMBLY WITH **NEW** FUEL PUMP

- Follow the Repair Manual instructions to reassemble the Fuel Suction Tube Assembly with a **NEW** Fuel Pump.



Refer to the Component diagrams at the beginning of these Technical Instructions to confirm the location of each replacement part.

Example Procedure:

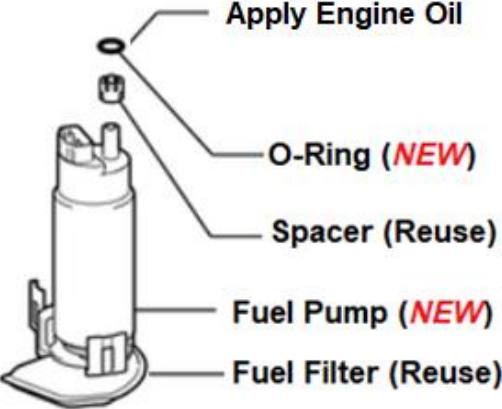
 <p>HINT: The reused filter may be discolored.</p>	<ul style="list-style-type: none">Remove the original O-Ring, Spacer and Fuel Filter from the original Fuel Pump.Discard the original O-Ring and Fuel Pump, <u>saving the Spacer and Fuel Filter.</u>Install the original Spacer onto the NEW Fuel Pump.Install the NEW O-Ring onto the NEW Fuel Pump. Refer to the Component Diagram to determine to proper O-Ring, as identified by the colored tape on the bag.Apply a small amount of engine oil to the NEW O-Ring to assure correct installation into the Tube Assembly.Install the original Fuel Filter onto the NEW Fuel Pump.Refer to the <u>Components diagrams</u> to review the other NEW parts to install.
---	--

- Apply engine oil to the **NEW** O-ring before assembly to assure correct installation into the Fuel Suction Tube.

3. REASSEMBLE FUEL SUCTION TUBE ASSEMBLY

b. Follow the Repair Manual instructions to reassemble the Fuel Suction Tube Assembly.

REASSEMBLE						
ES 350	2018	2019		IS 300	2018	2019
LC 500	2018	2019		IS 350	2018	2019
LC 500h	2018	2019		LS 500	2018	2019
GS 300	2018	2019		LS 500h	2018	2019
GS 350	2018	2019		IS 200t	2017	
RC 300	2018	2019		IS-F	2014	
RC 350	2018	2019		RC 200t	2017	

X. REINSTALL FUEL TUBE ASSEMBLY

1. INSTALL THE FUEL SUCTION TUBE ASSEMBLY INTO VEHICLE

a. Follow the Repair Manual instructions to reinstall the Fuel Suction Tube into the vehicle.



Refer to the Component diagrams at the beginning of these Technical Instructions to confirm the location of each replacement part.

INSTALLATION						
ES 350	2018	2019		IS 300	2018	2019
LC 500	2018	2019		IS 350	2018	2019
LC 500h	2018	2019		LS 500	2018	2019
GS 300	2018	2019		LS 500h	2018	2019
GS 350	2018	2019		IS 200t	2017	
RC 300	2018	2019		IS-F	2014	
RC 350	2018	2019		RC 200t	2017	

2. REMOVED FUEL

a. If fuel was removed from the tank prior to disassembly, reinstall the originally recovered fuel into the tank.



3. CHECK FOR DTC'S

- a. Using a Techstream, perform a Health Check to check for Diagnostic Trouble Codes.

Note: This Safety Recall covers only the replacement of the fuel pump and associated parts. It does not cover the diagnosis or replacement of any other parts on the vehicle.

◀ VERIFY REPAIR QUALITY ▶

- Confirm no fuel leaks from vehicle
- Confirm any fuel drained from the vehicle has been reinstalled
- Test drive to confirm normal operation while under load
- Confirm no DTC's are present
- Confirm that all parts listed in the Components Diagrams have been properly installed on the vehicle.

XI. APPENDIX

A. PARTS DISPOSAL

In accordance with Federal law, please make sure all recalled parts (original parts) removed from the vehicle are disposed of in a manner in which they will not be reused, **unless requested for parts recovery return.**

B. CAMPAIGN DESIGNATION DECORDER

