

Motorcycle/ATV Division

GS/GSX/GSX-R No. 252

March 22, 2021

## SAFETY RECALL CAMPAIGN 2A95 GSX250RL8 Headlamp Bulb

**Affected Models:** Certain 2018 GSX250R Models

**Affected Departments:** Management, Service, Warranty, Sales, Parts, Accessories

This notice is sent to you in accordance with the requirements of the National Traffic and Motor Vehicle Safety Act.

Suzuki Motor Corporation has decided that a defect which relates to motor vehicle safety exists in 2018 model-year GSX250R motorcycles.

### ***STOP DELIVERY OF AFFECTED VEHICLES IMMEDIATELY***

**DO NOT SELL OR DELIVER** an affected motorcycle to a customer until you have completed or verified completion of the repair procedures outlined in this bulletin.

**It is a violation of Federal law to sell or deliver any new motorcycle or item of motor vehicle equipment subject to a safety recall campaign under a sale or lease until the defect or non-compliance has been corrected.**

**In addition, selling an unrepaired affected motorcycle is a direct violation of your Suzuki dealer agreement and may lead to additional sanctions.**

### **What is the defect?**

The filament in the high/low beam headlamp bulb may break prematurely, resulting in sudden loss of illumination, which can reduce operator visibility and/or a clear view, increasing the risk of a crash.

### **What your dealership will do:**

- 1) Verify the unit is affected as instructed below.
- 2) Replace the headlamp bulb and install a retention spring clip with the countermeasure parts.
- 3) Submit a warranty claim.

<b><u>Affected Model</u></b>	<b><u>Model Year</u></b>	<b><u>VIN Range</u></b>
GSX250RL8	2018	LC6DN11A_J1100008 ~ LC6DN11A_J1102919

**Verify if the motorcycle is affected by the safety recall:**

Confirm the recall status by checking the vehicle identification number (VIN) against the Vehicle Master in Suzuki Connect to see if the motorcycle is eligible for the campaign inspection and replacement procedure. If you have a question regarding motorcycle eligibility, contact your Suzuki Technical Service Manager (TSM) or call Tech-Line at (714) 996-7480.

**What Suzuki Motor of America, Inc., will do:**

During the week of March 29, 2021, Suzuki Motor of America, Inc. (SMAI) will mail notifications to owners of affected motorcycles for whom we have information. The notice instructs the customer to contact a Suzuki dealer to schedule an appointment for the repair.

If you have sold an affected motorcycle to a customer prior to receiving this bulletin, please contact the customer immediately to arrange for the vehicle to be returned to your dealership for this safety recall campaign.

**Ordering parts for the Safety Recall Campaign:**

- You will be responsible for ordering parts for this recall campaign using the normal parts ordering procedure for each motorcycle.
- If you have any questions regarding your parts order, please contact National Parts Coordination at (714) 854-2165.

**Parts Ordering Information:**

**Model:** GSX250RL8  
**Part Description:** Bulb Set, Headlamp  
(1) Bulb  
(1) Clip, Headlamp  
(1) Leaflet  
**Part Number:** 35200-20810-RX0  
**Quantity Required:** 1

**NOTE:**  
*The countermeasure part features vibration resistance.*

*It is marked with an **ED** (1), and the stem (2) is extended and is inserted into the glass.*

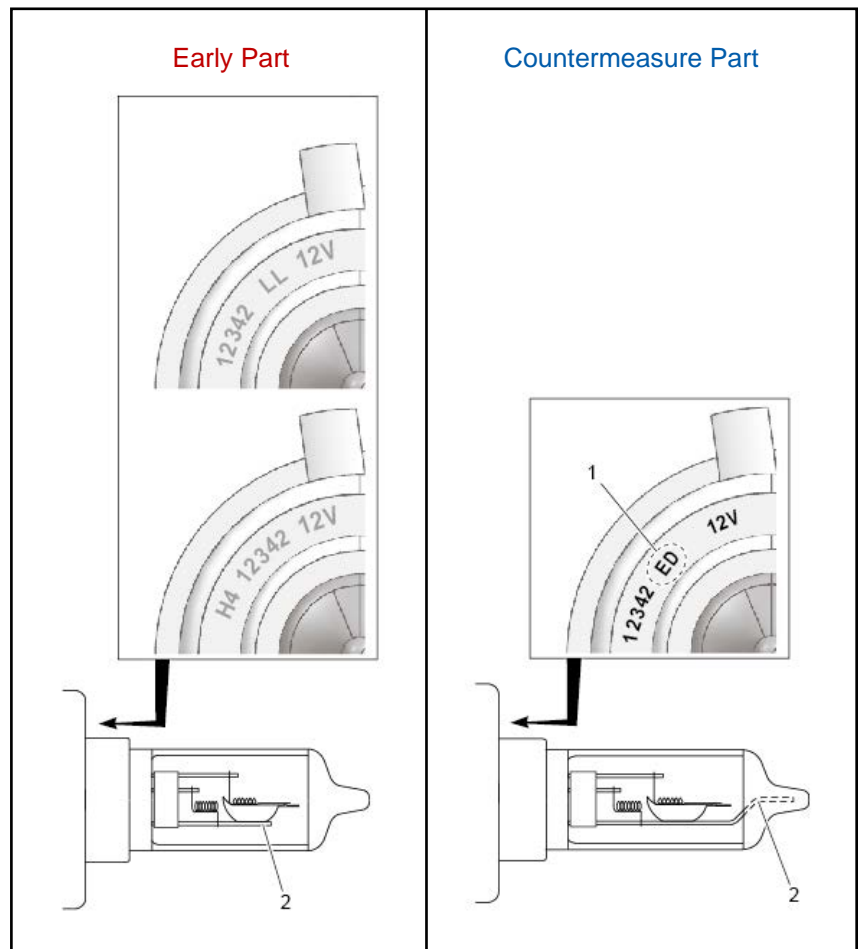

# Clip

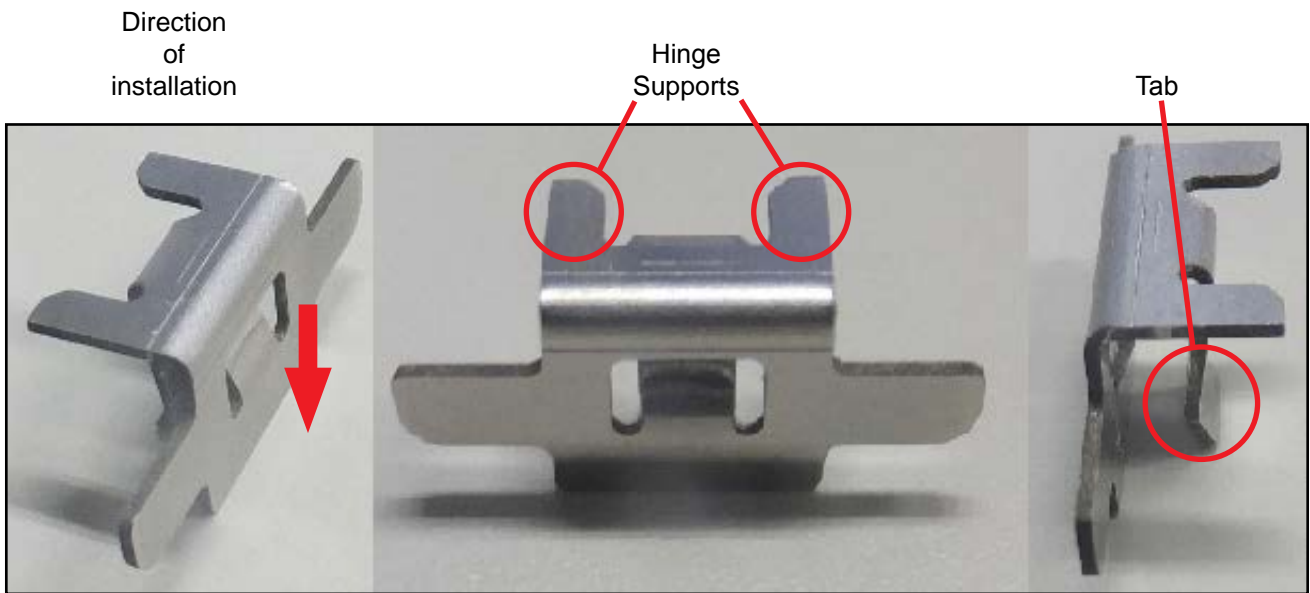

Install the clip onto the hinge of the bulb holder spring to prevent the spring from becoming misaligned.

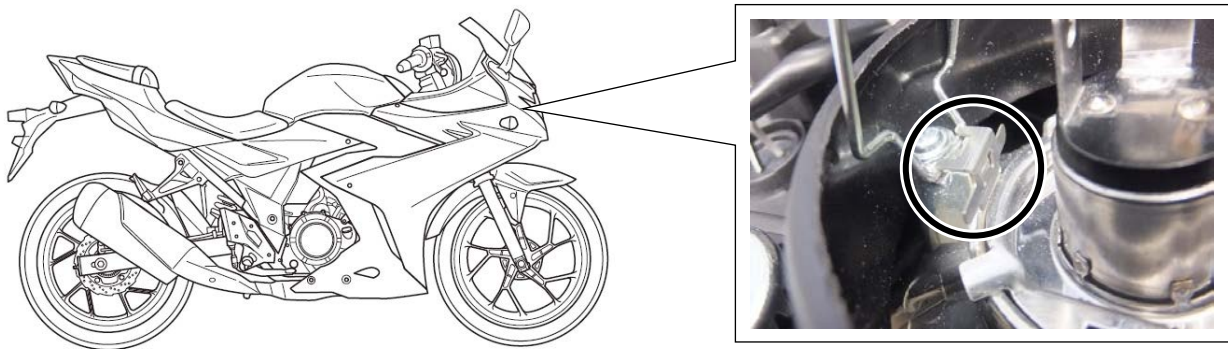

Follow the inspection and repair procedures as outlined in this Technical Service Bulletin (TSB).

**Warranty claim processing:**

Submit a warranty claim for each recall repair immediately upon completion. This campaign requires you to file a warranty claim using ONE of the methods described below.

**Suzuki Connect Short Campaign Claim:** The short campaign claim will reimburse you for the replacement of the headlamp bulb and 1.0 hour labor.

<b>CAMPAIGN 2A95 GSX250R HEADLAMP BULB SUZUKI CONNECT SHORT FORM INSTRUCTIONS</b>	
<b>CLAIM INFORMATION:</b>	
CLAIM NUMBER:	XXXXX,X (Dealer enters number)
ENTRY TYPE:	VIN, Model/Frame or Control/Sequence # (Dealer chooses)
REPAIR DATE:	Enter date of repair
MILEAGE:	Enter mileage at repair date
CAMPAIGN NUMBER:	2A95
LABOR OPERATION:	SA9999

**Suzuki Connect Long Campaign Claim:** The Long Campaign Claim will reimburse you for the replacement of the headlamp bulb, 1.0 hour labor, and additional parts and labor as authorized by your TSM.

<b>CAMPAIGN 2A95 GSX250R HEADLAMP BULB SUZUKI CONNECT LONG FORM INSTRUCTIONS</b>	
<b>CLAIM INFORMATION:</b>	
CLAIM NUMBER:	XXXXX,X (Dealer enters number)
ENTRY TYPE:	VIN, Model/Frame or Control/Sequence # (Dealer chooses)
REPAIR DATE:	Enter date of repair
MILEAGE:	Enter mileage at repair date
CAMPAIGN NUMBER:	2A95
<b>LABOR TIME:</b>	As authorized by your TSM
<b>PARTS INFORMATION:</b>	
ADDITIONAL PARTS:	Additional parts as authorized by your TSM
<b>AUTHORIZATION:</b>	Only needed if additional parts or labor claimed
<b>FAILURE DESCRIPTION:</b>	
DESCRIPTION OF DEFECT:	Headlamp bulb replacement
DESCRIPTION OF REPAIR:	Performed service campaign repair per service bulletin

**Precautions:**

- To avoid getting burned, do not touch the engine and exhaust system until they have cooled.
- Before the repair work, wash dirt from the vehicle to prevent contamination.
- When removing parts to be reused, arrange them in an orderly manner so they can be reinstalled in the proper order and orientation.
- Refer to the Service Manual for any details or procedures not mentioned in these instructions.

## **Repair Procedure:**

### **Removal:**

- 1) Remove the front seat (refer to Section 9D Seat Removal and Installation).
- 2) Remove the negative battery lead wire (1).
- 3) Remove the right and left rear view mirrors (refer to Section 9D Rear View Mirror Removal and Installation).



#### *NOTICE*

**The caps on the mirror fixing bolts can be damaged if not handled with care.**

**Use extra care not to damage the caps when removing the mirror fixing bolts.**

- 4) Remove the under center cowling (refer to Section 9D Under Center Cowling Removal and Installation).
- 5) Remove the right and left side cowling assemblies (refer to Section 9D Side Cowling / Inner Cowling / Under Cowling Removal and Installation).
- 6) Remove the right and left under cowlings (refer to Section 9D Side Cowling / Inner Cowling / Under Cowling Removal and Installation).
- 7) Remove the right and left frame side cover assemblies (refer to Section 9D Frame Side Front Cover / Frame Side Lower Cover / Frame Side Cover Removal and Installation).
- 8) Remove the body cowling assembly (refer to Section 9D Windscreen / Body Cowling / Meter Front Panel Removal and Installation).

#### *NOTE:*

*The windscreen does not need to be removed.*

**NOTICE**

The headlamp lens can be damaged if not handled with care during removal and installation.

Use extra care not to damage the headlamp lens during removal and installation.

- 9) Remove the headlamp coupler (1) and bulb socket rubber cap (2).

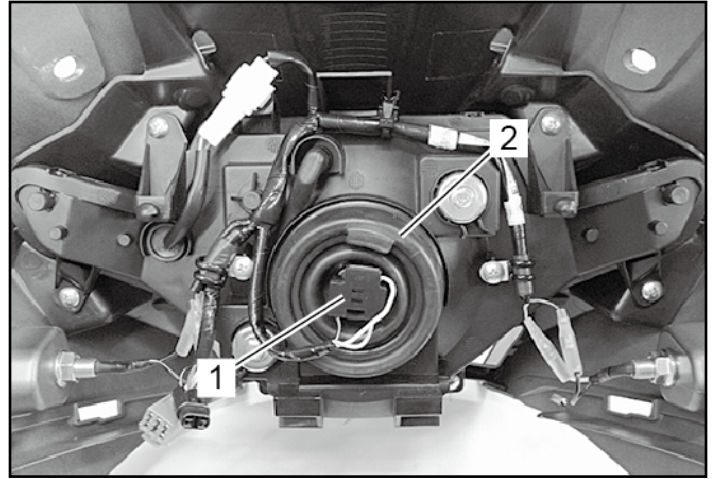

- 10) Check to see if a plate (1) is installed at the hinge part of the headlamp bulb holder spring. If a D-shaped plate secures the retaining spring, it is not necessary to replace the bulb and install the clip.

**No plate**

Replace the headlamp bulb and add the clip.

Go to step 11

**NOTE:**

There is a washer under the screw.

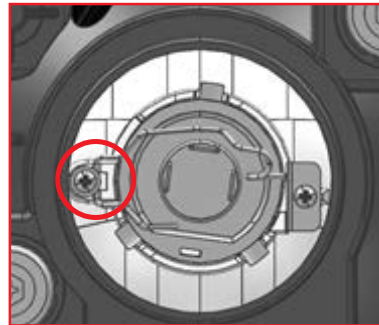

**With a plate**

If you see a D-shaped plate (1) used to secure the retaining spring, then it is not necessary to replace the bulb and install the clip.

Go to step 15.

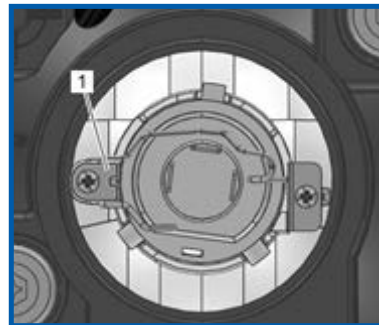



11) Unhook the bulb holder spring (1) from bracket of the headlamp body.

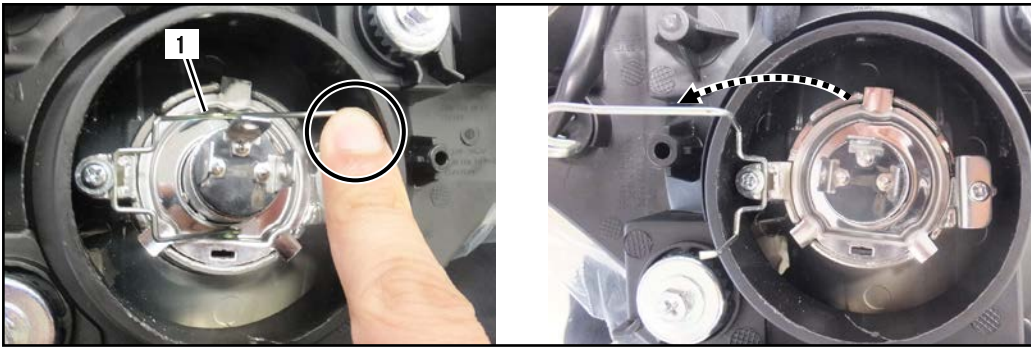

12) Install the clip as follows:

A) Align the center of the bulb holder spring (1) with the center of the screw (2).

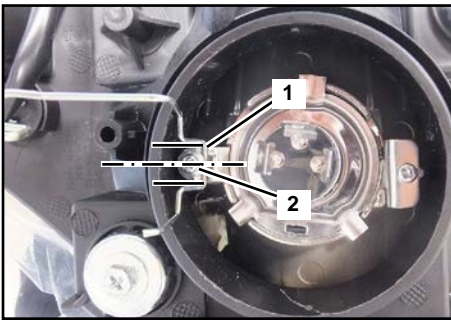

B) As illustrated in below, pinch the clip (1) and insert the tab (2) onto the clip into the hole in the spring mount (3).

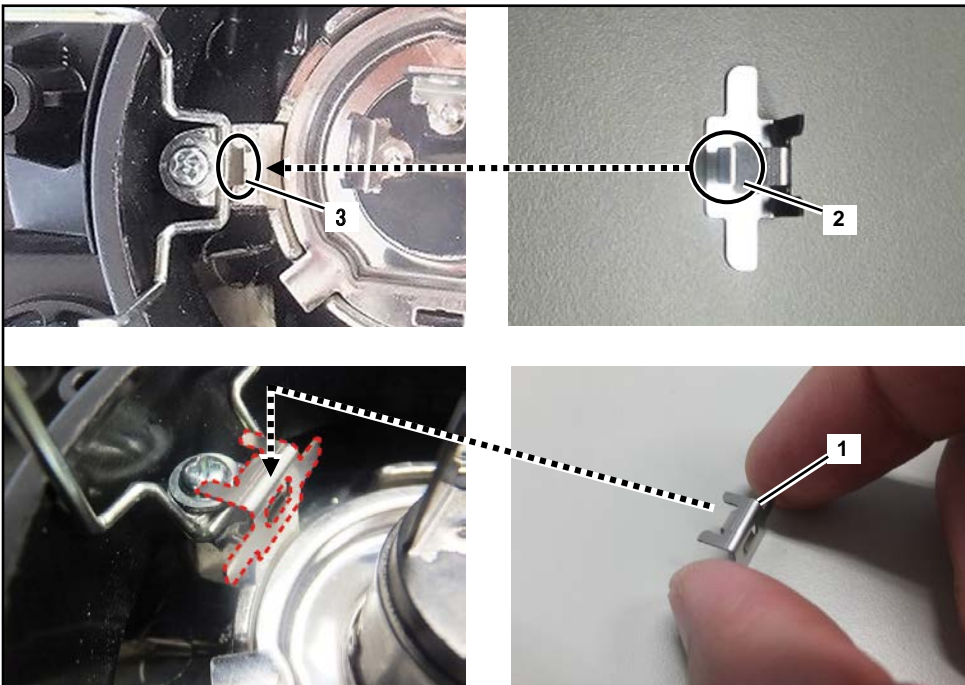

**NOTE:**

*If the clip is accidentally dropped into the headlamp, reverse the headlamp and remove the clip.*

C) Fully insert the clip (1) in the direction indicated by the arrow below.

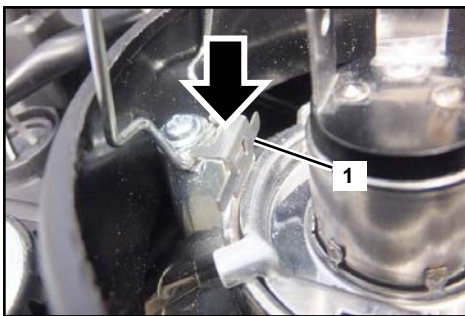

D) Confirm the clip is installed correctly as shown below.

**Correct installation**

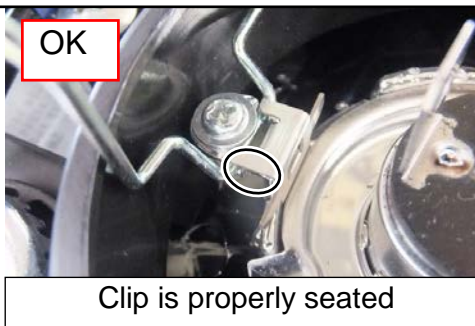
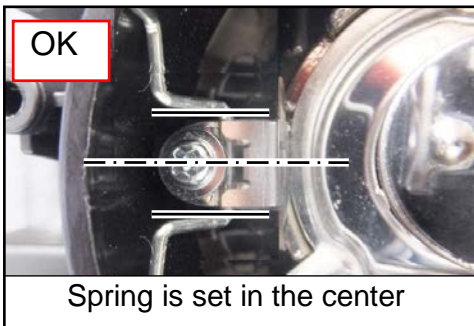

**Incorrect installation**

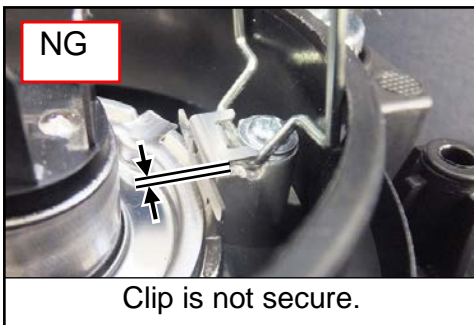
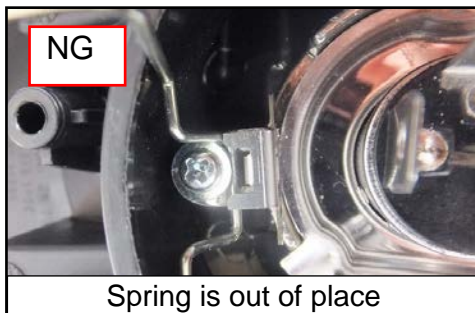

If the clip does not fit correctly, contact your Suzuki TSM.

Refer to the GSX250R Service Manual if it is necessary to replace the headlamp.



13) Replace with a countermeasure headlamp bulb (1).

**NOTICE**

Touching the glass portion of the countermeasure headlamp bulb with your fingers may deposit oils on the glass.

If you touch the bulb with your fingers, before installing the bulb, clean the glass of the bulb with a cloth moistened with alcohol or mild soapy water.

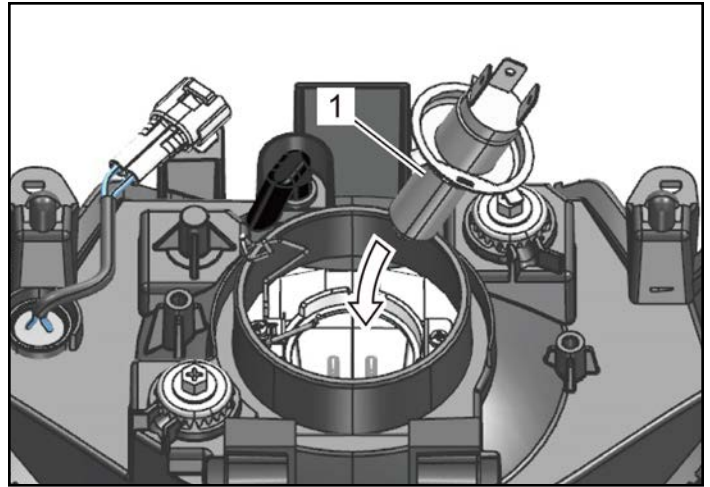

14) Hook the bulb holder spring(1) to bracket of the headlamp body.

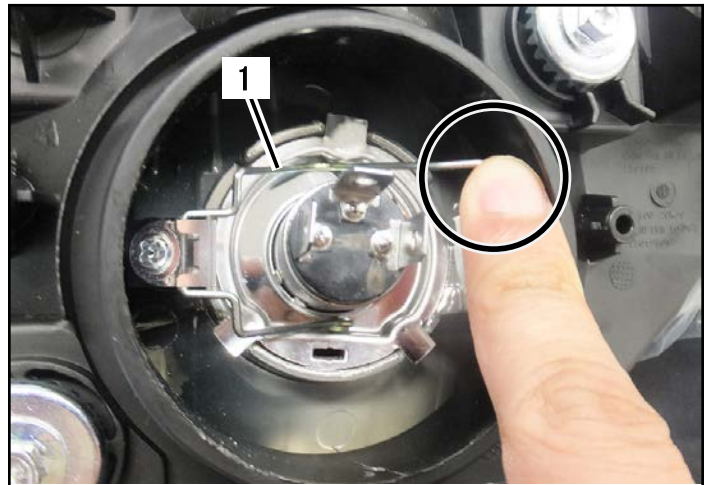

15) Install the bulb socket rubber cap (1) and headlamp coupler (2).

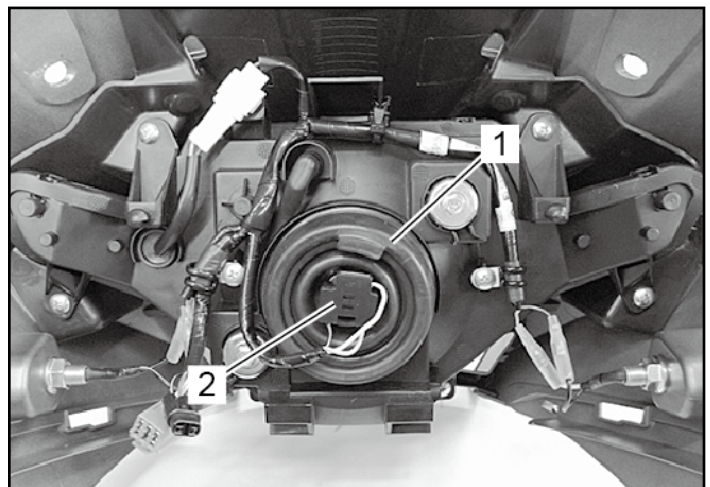

- 16) Install the body cowling assembly (refer to Section 9D Windscreen / Body Cowling / Meter Front Panel Removal and Installation).
- 17) Install the right and left frame side cover assemblies (refer to Section 9D Frame Side Front Cover / Frame Side Lower Cover / Frame Side Cover Removal and Installation).
- 18) Install the right and left under cowlings (refer to Section 9D Side Cowling / Inner Cowling / Under Cowling Removal and Installation).
- 19) Install the right and left side cowling assemblies (refer to Section 9D Side Cowling / Inner Cowling / Under Cowling Removal and Installation).
- 20) Install the under center cowling (refer to Section 9D Under Center Cowling Removal and Installation).
- 21) Install the right and left rear view mirrors (refer to Section 9D Rear View Mirror Removal and Installation).

**Tightening torque**

**Rear view mirror mounting bolt (a):  
10 N·m (7.3 lbf-ft)**

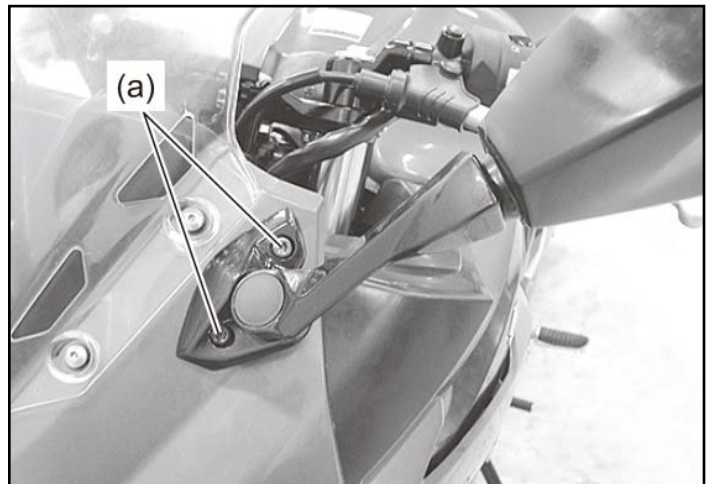

- 22) Connect the negative (–) battery lead wire (1)
- 23) Install the front seat (refer to section 9D Seat Removal and Installation.)
- 24) Final inspection:
  - Confirm each part is set and tightened securely.
  - Confirm the lights operate properly.
  - Adjust the headlamp beam position (refer to Section 9B Headlamp Beam Adjustment).
  - Set the time on the clock (Refer to Owner's manual).
  - Set the engine rpm indicator light (refer to the Owner's Manual).
  - When delivering the unit to the customer, provide them with the advisory pamphlet containing the recommendation to use a vibration-resistant bulb when replacing the headlamp bulb in the future.

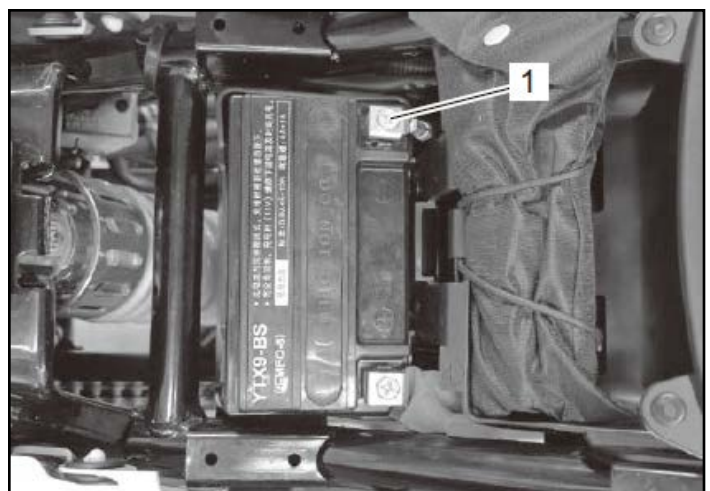



SUZUKI MOTOR OF AMERICA, INC.

## IMPORTANT SAFETY RECALL

This Notice Applies to Your Suzuki Vehicle Identification Number (VIN)

March 29, 2021

Dear Suzuki Owner:

This notice is sent to you in accordance with the requirements of the National Traffic and Motor Vehicle Safety Act.

Suzuki Motor Corporation has decided that a defect which relates to motor vehicle safety exists in certain model-year GSX250R motorcycles.

### **What is the defect and what will your dealership do to correct it?**

Suzuki Motor Corporation is initiating a safety recall campaign of 2018 GSX250R motorcycles.

The filament in the high/low beam headlamp bulb may break prematurely, resulting in sudden loss of illumination, which can reduce operator visibility and/or a clear view, increasing the risk of a crash.

Your Suzuki dealer will inspect your motorcycle and, if necessary, install an improved headlamp bulb and a retention spring clip. This procedure will take approximately one hour to complete. Parts are available now, and there will be no charge to you for any recall service-related parts or labor.

### **⚠ WARNING**

**Operating your motorcycle without having the recall service performed increases the risk of a crash.**

#### **To minimize the risk of a crash:**

- **Please do not ride nor allow anyone else to ride your motorcycle until this recall service has been completed.**
- **If you must ride your motorcycle before this safety recall service has been completed, check the stop lamp and other items for proper operation as outlined in the “INSPECTION BEFORE RIDING” checklist in section 4 of your owner’s manual before each ride.**

### **What you should do:**

Make sure you are prepared for the recall service by taking the following steps:

- Contact your dealer as soon as possible to make an appointment for the recall service. Be prepared to provide them with the VIN of your motorcycle (provided at the top of this notice).
- Please take this notice to your dealer to help your dealer process your claim.

### **What to do if you receive this notice in error:**

This notice was mailed to you according to the latest information that is available to us. If you no longer own the Suzuki motorcycle described in this notice, please complete and return the attached Change of Address/Ownership card to Suzuki Motor of America, Inc., and forward this recall information to the current owner (if known).

Federal regulations require that any vehicle lessor receiving this recall notice must forward a copy of this notice to the lessee within ten days.

**Customer reimbursement for prior repairs related to this safety recall:**

If your motorcycle is included in this recall and you have paid for repairs to address failure of the headlamp bulb, you may be eligible for full or partial reimbursement. Please note the following conditions for reimbursement:

- Only repairs made to address the defects that led to this recall are reimbursable. Additional expenses such as towing, car rental, accommodations, damage repairs, etc., will not be reimbursed. Reimbursement will not be provided for routine scheduled maintenance.
- Reimbursement may be limited to the suggested list price for parts, the Suzuki published flat-rate time allowance for the repair, and the labor rate that an authorized Suzuki dealer in the same area would charge for the same repair.
- An owner will not be eligible for reimbursement if the expenses for repairs are incurred more than 10 days after the date of this notice.
- Reimbursement claims may also be excluded when adequate documentation is not submitted by the claimant. This includes a proof of ownership, a repair order, and proof of payment for the repair.

To apply for reimbursement:

- 1) Go to [www.suzukicycles.com](http://www.suzukicycles.com).
- 2) Select Safety Recalls at the lower right side of the home page.
- 3) When the page refreshes, select Recall Notification Letters.
- 4) Select *GSX250R Headlamp Bulb Reimbursement*.

**Who to contact if you experience problems:**

Your Suzuki dealer can provide you the fastest response to your questions or concerns about this safety recall campaign. If you have any difficulty with this recall campaign, you may contact the Suzuki Motor of America, Inc., Customer Service Department for assistance at (714) 572-1490 during the hours of 8:00 AM to 4:00 PM Pacific Time. Please have your vehicle identification number (VIN) ready when calling.

If you need to locate your nearest Suzuki Motorcycle Dealer, please visit [www.suzukicycles.com](http://www.suzukicycles.com) and click on the "FIND A DEALER" tab, which is located in the upper right corner of our website.

If you believe that Suzuki Motor of America, Inc., has failed to provide the safety recall campaign service without charge or is unable to do so within a reasonable time, you may submit a complaint to the Administrator of the National Highway Traffic Safety Administration, 1200 New Jersey Ave., S.E., Washington D.C., 20590 or call the toll-free Vehicle Safety Hotline at 1-888-327-4236 (TTY: 1-888-424-9153) or go to [www.safercar.gov](http://www.safercar.gov).

We apologize for any inconvenience this recall campaign causes you. We hope you understand that your safety and satisfaction are important priorities for us.

Sincerely,

Suzuki Motor of America, Inc.